

S P E C I F I C A T I O N	(R - 0) 1 5 1 - E L C 0 9 D 2 R 2 F
CHOK E COIL (ELC09D-F/DF TYPE)	7 - 1

1. SCOPE

This specification covers the CHOK E COIL.

2. PART NUMBER OF PRODUCTS

This part number of the products in this specification shall be ELC09D□□□□F.

3. TEST CONDITIONS

The ambient temperature shall be 5°C to 35°C and the relative humidity 35% to 85%, unless otherwise specified. When the test result is doubtful, the sample in question shall be tested again at 20±2°C, 65±5%RH.

4. APPERANCE, DIMENSIONS AND CONSTRUCTION

Inductors shall be free from distortion, damage or contaminants, and shall be within dimensions specified.

5. ELECTRICAL CHARACTERISTICS

As specified in the characteristics table.

6. RELIABILITY CHARACTERISTICS

As specified in the characteristics table.

7. PACKAGE

The products shall be packed so as not allow water absorption and damage.

The following indications shall be marked on the package:

1. Part No. 2. Quantity 3. Manufacturer's name

8. OPERATING TEMPERATURE

- 2 0 ~ 1 0 5 ° C (Including Self-Temperature-Rise)

9 OTHERS

The customer is requested to store the products at the normal temperature (-25°C to 60°C) and the normal humidity (85%RH max.) in the packages we supplied.

The package shall not be exposed to direct sunlight and harmful gas and care should be taken so as not to cause dew.

REVISION	NO.	DATE	REVISION	CHECK	NO.	DATE	REVISION	CHECK
DATE ENFORCED				APPROVAL			CHECK	DESIGN
Feb . 19 . 1999				MATSUSHITA ELECTRONIC COMPONENTS CO.,LTD.			<i>T. Higashimura</i> <i>M. Yamada</i> <i>J. Komori</i>	

S P E C I F I C A T I O N

151-ELC09D2R2F

CHOKE COIL (ELC09D-F/DF TYPE)

7 - 3

[PACKAGING]
1. TAPING
DIMENSIONS

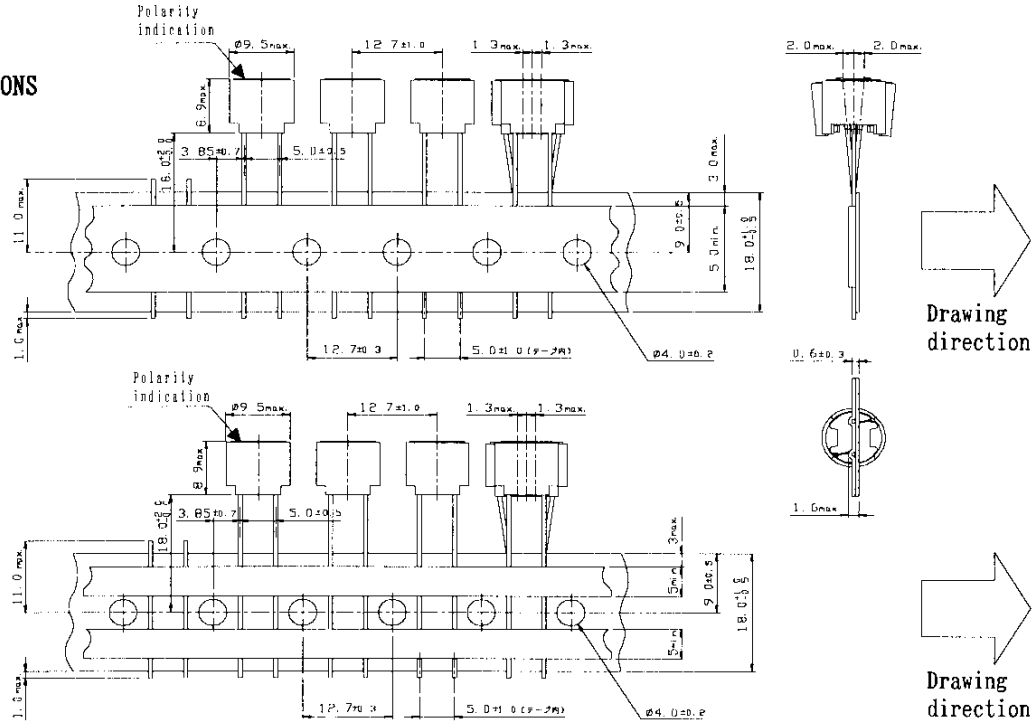

(Note1) The tolerance of 20 pitches shall be within 1mm.
 (Note2) Taping shall be which of upper figure.

2. Defective inductor

Defective inductor shall be removed from the tape as shown below.
 Number of defective inductor shall not exceed 3 pieces continuous.

3. Splicing of tape

Two inductor shall be removed from part of mount connection.
 Part of connection shall be positioned more than 5 inductors from crease.
 Connection number for each taping per packaging shall not exceed more than 2 points.
 (The thickness part of mount connection shall not exceed more than 1.6mm.)

4. Structure of packing

< Taping >
 1 reel Single contents 500 pcs.

< Individual packing >
 Inside Packing Single contents 100 pcs.
 Outside Packing Single contents 1000 pcs.

5. Contents of packing

Outside Packing is Packing case.

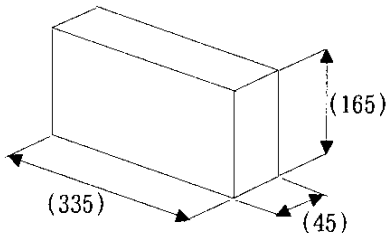
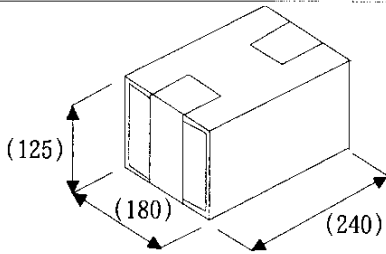
Taping			Individual packing		
					
Weight	Weight / pc.	About 1.4 g	Weight	Weight / pc.	About 1.4 g
	Weight/packing	About 0.80kg		Weight/packing	About 1.5 kg

6. Packing indication

We shall indicate customers parts number, our parts number, quantity and other items on one side of the package.

S P E C I F I C A T I O N

151-ELC09D2R2F

CHOKE COIL (ELC09D-F/DF TYPE)

7 - 2

[APPEARANCE, DIMENSIONS AND CONSTRUCTION]

[UNIT : mm]

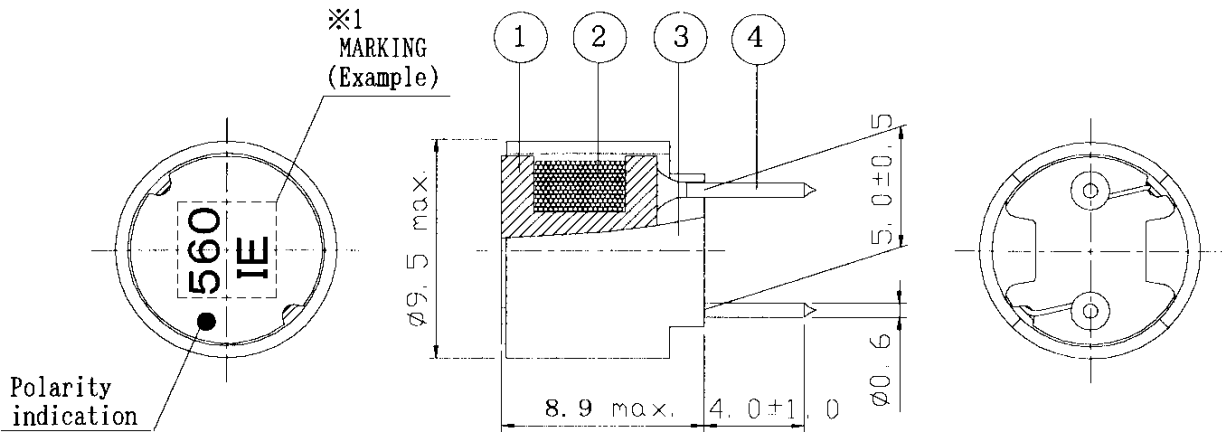

MOUNTING DETAILS

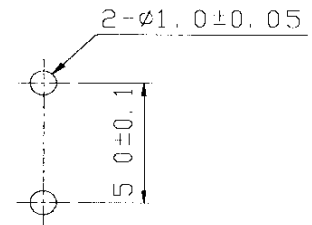

※1 Marking ; Inductance , polarity (winding start)
& manufacturing code

(ex.) Inductance ; 4.7 μ H:4R7, 56 μ H:560, 100 μ H:101

ITEM	PART NAME	MATERIALS	MANUFACTURE
1	CORE	FERRITE	OPTION
2	COIL	POLYURETHANE ENAMELED COPPER WIRE	OPTION
3	CASE	POLYPROPYLENE RESIN	OPTION
4	TERMINAL	COPPER PLYWIRE	OPTION

[PART NUMBER]

E
L
C
0
9
D
□
□
□
□
F

1
2
3
4
5
6

1	ITEM	CHOKE COIL
2	SHAPE	CORE SIZE (ex.) 09 : ϕ 9
3	STRUCTURE	COMBINATION OF CORE AND TERMINAL. (ex.) D : CORE + TERMINAL
4	INDUCTANCE	INDUCTANCE ; (ex.) 101 : 100 μ H , 560 : 56 μ H
5	PACKING	D : TAPING (INDIVIDUAL PACKING IS OMISSION)
6	TYPE	F : STANDARD TYPE

MATSUSHITA ELECTRONIC COMPONENTS CO., LTD.

S P E C I F I C A T I O N

151-ELC09D2R2F

CHOKE COIL (ELC09D-F/DF TYPE)

7 - 4

(ELECTRICAL CHARACTERISTICS)

CUSTOMER'S PART NUMBER	MATSUSHITA'S PART NUMBER	INDUCTANCE (μ H)	TOLERANCE (%)	TEST FREQ. (kHz)	[at20°C] DCR ($\Omega \pm 20\%$)	[at20°C] I DC (A max.)	TYPE OF WIRE (UEW- ϕ)	※1 NO. OF TURNS (Ts)
ELC09D2R2□F	ELC09D2R2□F	2.2	±20	10	0.012	3.5	0.45	7.5
ELC09D2R7□F	ELC09D2R7□F	2.7	±20	10	0.013	3.3	0.45	8.5
ELC09D3R3□F	ELC09D3R3□F	3.3	±20	10	0.015	3.2	0.45	9.5
ELC09D3R9□F	ELC09D3R9□F	3.9	±20	10	0.016	3.1	0.45	10.5
ELC09D4R7□F	ELC09D4R7□F	4.7	±20	10	0.018	3.0	0.45	11.5
ELC09D5R6□F	ELC09D5R6□F	5.6	±20	10	0.019	2.9	0.45	12.5
ELC09D6R8□F	ELC09D6R8□F	6.8	±20	10	0.021	2.8	0.45	13.5
ELC09D8R2□F	ELC09D8R2□F	8.2	±20	10	0.024	2.6	0.45	15.5
ELC09D100□F	ELC09D100□F	10	±20	10	0.027	2.5	0.45	16.5
ELC09D120□F	ELC09D120□F	12	±20	10	0.031	2.3	0.45	18.5
ELC09D150□F	ELC09D150□F	15	±20	10	0.035	2.1	0.45	20.5
ELC09D180□F	ELC09D180□F	18	±20	10	0.038	2.0	0.45	22.5
ELC09D220□F	ELC09D220□F	22	±10	10	0.051	1.8	0.40	24.5
ELC09D270□F	ELC09D270□F	27	±10	10	0.058	1.6	0.40	27.5
ELC09D330□F	ELC09D330□F	33	±10	10	0.081	1.4	0.35	30.5
ELC09D390□F	ELC09D390□F	39	±10	10	0.087	1.3	0.35	32.5
ELC09D470□F	ELC09D470□F	47	±10	10	0.11	1.2	0.32	36.5
ELC09D560□F	ELC09D560□F	56	±10	10	0.13	1.1	0.32	39.5
ELC09D680□F	ELC09D680□F	68	±10	10	0.14	1.0	0.32	44.5
ELC09D820□F	ELC09D820□F	82	±10	10	0.16	0.90	0.32	48.5
ELC09D101□F	ELC09D101□F	100	±10	10	0.20	0.82	0.30	53.5
ELC09D121□F	ELC09D121□F	120	±10	10	0.25	0.77	0.28	58.5
ELC09D151□F	ELC09D151□F	150	±10	10	0.32	0.74	0.26	65.5
ELC09D181□F	ELC09D181□F	180	±10	10	0.36	0.61	0.26	72.5
ELC09D221□F	ELC09D221□F	220	±10	10	0.41	0.58	0.26	80.5
ELC09D271□F	ELC09D271□F	270	±10	10	0.50	0.52	0.25	89.5
ELC09D331□F	ELC09D331□F	330	±10	10	0.65	0.49	0.23	98.5
ELC09D391□F	ELC09D391□F	390	±10	10	0.86	0.46	0.20	105.5
ELC09D471□F	ELC09D471□F	470	±10	10	0.98	0.39	0.20	116.5
ELC09D561□F	ELC09D561□F	560	±10	10	1.1	0.36	0.20	127.5
ELC09D681□F	ELC09D681□F	680	±10	10	1.4	0.34	0.18	140.5
ELC09D821□F	ELC09D821□F	820	±10	10	1.6	0.30	0.18	155.5
ELC09D102□F	ELC09D102□F	1,000	±10	10	2.1	0.28	0.16	168.5
ELC09D122□F	ELC09D122□F	1,200	±10	10	2.4	0.23	0.16	185.5
ELC09D152□F	ELC09D152□F	1,500	±10	10	2.8	0.21	0.16	210.5
ELC09D182□F	ELC09D182□F	1,800	±10	10	3.8	0.19	0.14	227.5
ELC09D222□F	ELC09D222□F	2,200	±10	10	4.4	0.17	0.14	254.5
ELC09D272□F	ELC09D272□F	2,700	±10	10	6.1	0.16	0.12	276.5
ELC09D332□F	ELC09D332□F	3,300	±10	10	7.0	0.14	0.12	308.5
ELC09D392□F	ELC09D392□F	3,900	±10	10	8.0	0.13	0.12	338.5
ELC09D472□F	ELC09D472□F	4,700	±10	10	11.2	0.12	0.10	361.5
ELC09D562□F	ELC09D562□F	5,600	±10	10	12.6	0.11	0.10	397.5
ELC09D682□F	ELC09D682□F	6,800	±10	10	14.4	0.10	0.10	440.5
ELC09D822□F	ELC09D822□F	8,200	±10	10	16.6	0.09	0.10	488.5
ELC09D103□F	ELC09D103□F	10,000	±10	10	18.8	0.08	0.10	541.5

※1 Number of turn is the standard value which may change in order to assure characteristics.

MATSUSHITA ELECTRONIC COMPONENTS CO., LTD.

S P E C I F I C A T I O N

151-ELC09D2R2F

CHOKE COIL (ELC09D-F/DF TYPE)

7 - 5

(ELECTRICAL CHARACTERISTICS)

	ITEM	SPECIFICATION	TEST METHOD / CONDITION
ELECTRICAL CHARACTERISTICS	INDUCTANCE	Refer to individual part number specifications.	LCR METER (HP4284A) or Equivalence Vosc = 0.3Vrms
	DC RESISTANCE	Refer to individual part number specifications.	DIGITAL MULTIMETER (FLUKE 8505A) or Equivalence
	RATED CURRENT	Refer to individual part number specifications.	Passing DC rated current. Inductance : Lo-10% max. Temperature rise : 45k {deg.} max.
	INSULATION RESISTANCE	100MΩ min.	Applying DC100V between coil & core.
	WITHSTANDING VOLTAGE	Shall not be noticeably damaged.	Applying DC100V between coil & core for 1 minute.

(RELIABILITY CHARACTERISTICS (2-1))

	ITEM	SPECIFICATION	TEST METHOD / CONDITION
ENVIRONMENTAL	TEMPERATURE CHARACTERISTICS	Inductance shall not change more than $\pm 10\%$.	-25°C ~ 85°C Standard : Values at 20°C
	HUMIDITY CHARACTERISTICS	Inductance shall not change more than $\pm 5\%$.	Inductors shall be subjected to 90~95%RH at 60°C \pm 2°C for 500 hours. Measurements shall be made after 1 hour stabilization at room temperature.
	HEAT RESISTANCE	Inductance shall not change more than $\pm 5\%$.	Inductors shall be subjected to 85 \pm 2°C for 500 hours. Measurements shall be made after 1 hour stabilization at room temperature.
	LOW TEMPERATURE STORAGE	Inductance shall not change more than $\pm 5\%$.	Inductors shall be subjected to -25 \pm 2°C for 500 hours. Measurements shall be made after 1 hour stabilization at room temperature.
	THERMAL SHOCK	Inductance shall not change more than $\pm 5\%$.	Inductors shall be subjected 20 times to the following temperature cycle. 1. -25 \pm 3°C / 30 minutes 2. 85 \pm 2°C / 30 minutes Measurements shall be made after 1 hour stabilization at room temperature.

MATSUSHITA ELECTRONIC COMPONENTS CO.,LTD.

S P E C I F I C A T I O N

151-ELC09D2R2F

CHOKER COIL (ELC09D-F/DF TYPE)

7 - 6

〔 RELIABILITY CHARACTERISTICS (2-2) 〕

	ITEM	SPECIFICATION	TEST METHOD / CONDITION
L I F E	HUMIDITY LOAD LIFE	1. There shall be no case deformation or change in appearance. 2. There shall be no evidence of intermittent contact or open circuiting.	With 110% of rated current applied, inductors shall be subjected to 90~95%RH at 60±2°C for 500 hours. Measurements shall be made after 1 hour stabilization at room temperature.
	HIGH TEMPERATURE LOAD LIFE	1. There shall be no case deformation or change in appearance. 2. There shall be no evidence of intermittent contact or open circuiting.	With 110% of rated current applied, inductors shall be stored at 85±2°C for 500 hours. Measurements shall be made after 1 hour stabilization at room temperature.
M E C H A N I C A L C H A R A C T E R I S T I C S	SOLDERABILITY	The terminals shall be at least 90% covered with solder.	After fluxing, inductors shall be dipped in a melted solder bath at 230±5°C for 2±0.5 seconds.
	RESISTANCE TO SOLDERING HEAT	1. Inductance shall not change more than ±5%. 2. There shall be no case deformation or change in appearance.	Inductors shall be dipped in a melted solder bath at 270±5°C for 5±0.5 seconds up to 1.0 to 1.5 mm from attachment surface.
	VIBRATION, LOW FREQUENCY	1. Inductance shall not change more than ±5%. 2. There shall be no case deformation or change in appearance.	Amplitude : 1.5 mm Frequency : 10~55Hz Period : 60sec. Motion shall be applied for 2 hours in each of the 3 mutually perpendicular directions.
	TERMINAL PULL STRENGTH	1. There shall be no case deformation or change in appearance. 2. There shall be no evidence of intermittent contact or open circuiting.	The terminal shall be pulled 10N for 30±5 seconds in the axis directions.
	SHOCK	1. Inductance shall not change more than ±5%. 2. There shall be no case deformation or change in appearance.	Inductors shall be dropped 3 times from a height of 50cm onto a wooden board.

⚠ Cautions for use

- ◎ Don't load in disorder or pile coil products.
- ◎ The main part : a core may be damaged when excessive force or shock are applied.
Do not use dropped products.
- ◎ Some ultrasonic cleaning device will damage coil by its resonance wave.
Please confirm with your device when this coil is used.

S P E C I F I C A T I O N

151-ELC09D2R2F

CHOKE COIL (ELC09D-F/DF TYPE)

7 - 7

[STANDARDS FOR GIVING DATE CODE]

1.Manufacturing department in Japan

2.Overseas operating unit

(1) (2)

(2) (1)

(1)Indication by combination of manufacturing year and month

Year \ Month	1	2	3	4	5	6	7	8	9	10	11	12
Year of odd number	A	B	C	D	E	F	H	I	J	K	L	M
Year of even number	N	O	P	R	S	T	U	V	W	X	Y	Z

(2)Indication of manufacturing department

[Japan]

TAJIMA MATSUSHITA ELECTRIC CO.,LTD. T

[Overseas]

SINCOM G
 SINCOM-BT Q
 UKCOM U
 PGCOR I
 TCOM N
 PACOB Z