

## General Description

The SX1211 is a low cost single-chip transceiver operating in the frequency ranges from 863-870, 902-928 MHz and 950-960 MHz. The SX1211 is optimized for very low power consumption (3mA in receiver mode). It incorporates a baseband modem with data rates up to 200 kb/s. Data handling features include a sixty-four byte FIFO, packet handling, automatic CRC generation and data whitening. Its highly integrated architecture allows for minimum external component count whilst maintaining design flexibility. All major RF communication parameters are programmable and most of them may be dynamically set. It complies with European (ETSI EN 300-220 V2.1.1) and North American (FCC part 15.247 and 15.249) regulatory standards.

## Ordering Information

Table 1: Ordering Information

Part number	Delivery	Minimum Order Quantity / Multiple
SX1211I084TRT	Tape & Reel	3000 pieces
SX1211I084T	Tray	200 pieces

- TQFN-32 package – Operating range [-40;+85°C]
- T refers to Lead Free packaging
- This device is WEEE and RoHS compliant

## Application Circuit Schematic

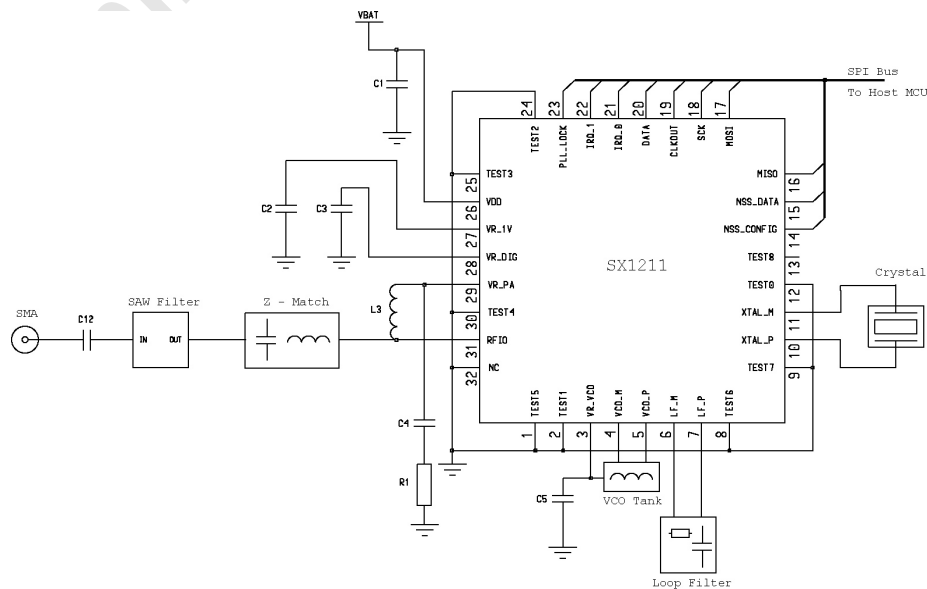

## Features

- Low Rx power consumption: 3mA
- Low Tx power consumption: 25 mA @ +10 dBm
- Good reception sensitivity: down to -107 dBm at 25 kb/s in FSK, -113 dBm at 2kb/s in OOK
- Programmable RF output power: up to +12.5 dBm in 8 steps
- Packet handling feature with data whitening and automatic CRC generation
- Wide RSSI (Received Signal Strength Indicator) dynamic range, 70dB from Rx noise floor
- Bit rates up to 200 kb/s, NRZ coding
- On-chip frequency synthesizer
- FSK and OOK modulation
- Incoming sync word recognition
- Built-in Bit-Synchronizer for incoming data and clock synchronization and recovery
- 5 x 5 mm TQFN package
- Optimized Circuit Configuration for Low-cost applications

## Applications

- Wireless alarm and security systems
- Wireless sensor networks
- Automated Meter Reading
- Home and building automation
- Industrial monitoring and control
- Remote Wireless Control

## Table of Contents

1. General Description.....	5	5.3.1. General Description .....	41
1.1. Simplified Block Diagram .....	5	5.3.2. Tx Processing .....	41
1.2. Pin Diagram.....	6	5.3.3. Rx Processing.....	42
1.3. Pin Description .....	7	5.3.4. Interrupt Signals Mapping .....	42
2. Electrical Characteristics .....	8	5.3.5. uC Connections .....	43
2.1. ESD Notice.....	8	5.3.6. Continuous Mode Example .....	43
2.2. Absolute Maximum Ratings .....	8	5.4. Buffered Mode .....	44
2.3. Operating Range .....	8	5.4.1. General Description .....	44
2.4. Chip Specification.....	8	5.4.2. Tx Processing .....	44
2.4.1. Power Consumption .....	8	5.4.3. Rx Processing.....	45
2.4.2. Frequency Synthesis .....	9	5.4.4. Interrupt Signals Mapping .....	46
2.4.3. Transmitter .....	9	5.4.5. uC Connections .....	47
2.4.4. Receiver .....	10	5.4.6. Buffered Mode Example.....	47
2.4.5. Digital Specification .....	11	5.5. Packet Mode.....	49
3. Architecture Description.....	12	5.5.1. General Description .....	49
3.1. Power Supply Strategy.....	12	5.5.2. Packet Format .....	49
3.2. Frequency Synthesis Description.....	13	5.5.3. Tx Processing .....	51
3.2.1. Reference Oscillator .....	13	5.5.4. Rx Processing.....	51
3.2.2. CLKOUT Output .....	13	5.5.5. Packet Filtering .....	52
3.2.3. PLL Architecture .....	14	5.5.6. DC-Free Data Mechanisms.....	53
3.2.4. PLL Tradeoffs.....	14	5.5.7. Interrupt Signal Mapping .....	54
3.2.5. Voltage Controlled Oscillator.....	15	5.5.8. uC Connections .....	55
3.2.6. PLL Loop Filter .....	16	5.5.9. Packet Mode Example .....	56
3.2.7. PLL Lock Detection Indicator .....	16	5.5.10. Additional Information .....	56
3.2.8. Frequency Calculation .....	16	6. Configuration and Status Registers.....	58
3.3. Transmitter Description.....	18	6.1. General Description .....	58
3.3.1. Architecture Description.....	18	6.2. Main Configuration Register - MCPParam.....	58
3.3.2. Bit Rate Setting.....	19	6.3. Interrupt Configuration Parameters - IRQParam .....	60
3.3.3. Alternative Settings.....	19	6.4. Receiver Configuration parameters - RXParam .....	62
3.3.4. Fdev Setting in FSK Mode .....	19	6.5. Sync Word Parameters - SYNCParam.....	63
3.3.5. Fdev Setting in OOK Mode .....	19	6.6. Transmitter Parameters - TXParam .....	64
3.3.6. Interpolation Filter.....	20	6.7. Oscillator Parameters - OSCParam .....	64
3.3.7. Power Amplifier .....	20	6.8. Packet Handling Parameters – PKTParam .....	65
3.3.8. Common Input and Output Front-End .....	22	7. Application Information .....	66
3.4. Receiver Description.....	23	7.1. Crystal Resonator Specification .....	66
3.4.1. Architecture .....	23	7.2. Software for Frequency Calculation .....	66
3.4.2. LNA and First Mixer .....	24	7.2.1. GUI.....	66
3.4.3. IF Gain and Second I/Q Mixer.....	24	7.2.2. .dll for Automatic Production Bench .....	66
3.4.4. Channel Filters .....	24	7.3. Switching Times and Procedures .....	66
3.4.5. Channel Filters Setting in FSK Mode .....	25	7.3.1. Optimized Receive Cycle.....	67
3.4.6. Channel Filters Setting in OOK Mode .....	26	7.3.2. Optimized Transmit Cycle .....	68
3.4.7. RSSI.....	26	7.3.3. Transmitter Frequency Hop Optimized Cycle.....	69
3.4.8. Fdev Setting in Receive Mode .....	28	7.3.4. Receiver Frequency Hop Optimized Cycle.....	70
3.4.9. FSK Demodulator .....	28	7.3.5. Rx→Tx and Tx→Rx Jump Cycles .....	71
3.4.10. OOK Demodulator .....	28	7.4. Reset of the Chip .....	72
3.4.11. Bit Synchronizer .....	31	7.4.1. POR.....	72
3.4.12. Alternative Settings .....	32	7.4.2. Manual Reset.....	72
3.4.13. Data Output .....	32	7.5. Reference Design .....	73
4. Operating Modes.....	33	7.5.1. Application Schematic.....	73
4.1. Modes of Operation .....	33	7.5.2. PCB Layout .....	73
4.2. Digital Pin Configuration vs. Chip Mode .....	33	7.5.3. Bill Of Material .....	74
5. Data Processing .....	34	7.5.4. SAW Filter Plot .....	75
5.1. Overview .....	34	7.5.5. Ordering Information for Tools .....	75
5.1.1. Block Diagram .....	34	7.6. Reference Design Performance .....	76
5.1.2. Data Operation Modes.....	34	7.6.1. Sensitivity Flatness .....	77
5.2. Control Block Description.....	35	7.6.2. Sensitivity vs. LO Drift.....	78
5.2.1. SPI Interface.....	35	7.6.3. Sensitivity vs. Receiver BW .....	79
5.2.2. FIFO .....	38	7.6.4. Sensitivity Stability over Temperature and Voltage.....	80
5.2.3. Sync Word Recognition .....	40	7.6.5. Sensitivity vs. Bit Rate .....	80
5.2.4. Packet Handler .....	40	7.6.6. Adjacent Channel Rejection.....	81
5.2.5. Control.....	40	7.6.7. Output Power Flatness.....	82
5.3. Continuous Mode .....	41	7.6.8. Pout and IDD vs. PA Setting .....	83

7.6.9. Pout Stability over Temperature and Voltage .....	84	8. Packaging Information .....	90
7.6.10. Transmitter Spectral Purity .....	85	8.1. Package Outline Drawing.....	90
7.6.11. OOK Channel Bandwidth.....	86	8.2. PCB Land Pattern.....	90
7.6.12. FSK Spectrum in Europe .....	87	8.3. Tape & Reel Specification.....	91
7.6.13. Digital Modulation Schemes.....	88	9. Revision History.....	92
7.6.14. Current Stability over Temperature and Voltage .....	89	10. Contact Information .....	92

## Index of Figures

Figure 1: SX1211 Simplified Block Diagram .....	5	Figure 46: Manchester Encoding/Decoding .....	54
Figure 2: SX1211 Pin Diagram .....	6	Figure 47: Data Whitening .....	54
Figure 3: SX1211 Detailed Block Diagram.....	12	Figure 48: uC Connections in Packet Mode .....	55
Figure 4: Power Supply Breakdown.....	13	Figure 49: Optimized Rx Cycle .....	67
Figure 5: Frequency Synthesizer Description.....	14	Figure 50: Optimized Tx Cycle.....	68
Figure 6: LO Generator .....	14	Figure 51: Tx Hop Cycle .....	69
Figure 7: Loop Filter .....	16	Figure 52: Rx Hop Cycle.....	70
Figure 8: Transmitter Architecture .....	18	Figure 53: Rx → Tx → Rx Cycle .....	71
Figure 9: I(t), Q(t) Overview .....	18	Figure 54: POR Timing Diagram.....	72
Figure 10: PA Control .....	21	Figure 55: Manual Reset Timing Diagram.....	72
Figure 11: Optimal Load Impedance Chart .....	21	Figure 56: Reference Design Circuit Schematic.....	73
Figure 12: Recommended PA Biasing and Output Matching .....	22	Figure 57: Reference Design's Stackup.....	74
Figure 13: Front-end Description .....	22	Figure 58: Reference Design Layout (top view) .....	74
Figure 14: Receiver Architecture .....	23	Figure 59: 915 MHz SAW Filter Plot .....	75
Figure 15: FSK Receiver Setting .....	23	Figure 60: 869 MHz SAW Filter Plot .....	75
Figure 16: OOK Receiver Setting .....	23	Figure 61: Sensitivity Across the 868 MHz Band.....	77
Figure 17: Active Channel Filter Description .....	24	Figure 62: Sensitivity Across the 915 MHz Band.....	77
Figure 18: Butterworth Filter's Actual BW .....	26	Figure 63: FSK Sensitivity Loss vs. LO Drift.....	78
Figure 19: Polyphase Filter's Actual BW .....	26	Figure 64: OOK Sensitivity Loss vs. LO Drift.....	78
Figure 20: RSSI Dynamic Range.....	27	Figure 65: FSK Sensitivity vs. Rx BW .....	79
Figure 21: RSSI IRQ Timings .....	28	Figure 66: OOK Sensitivity Change vs. Rx BW .....	79
Figure 22: OOK Demodulator Description.....	29	Figure 67: Sensitivity Stability .....	80
Figure 23: Floor Threshold Optimization .....	30	Figure 68: FSK Sensitivity vs. BR .....	80
Figure 24: BitSync Description.....	31	Figure 69: OOK Sensitivity vs. BR .....	81
Figure 25: SX1211's Data Processing Conceptual View .....	34	Figure 70: ACR in FSK Mode.....	81
Figure 26: SPI Interface Overview and uC Connections .....	35	Figure 71: ACR in OOK Mode.....	82
Figure 27: Write Register Sequence.....	36	Figure 72: Pout for 869 MHz Band Operation .....	82
Figure 28: Read Register Sequence.....	37	Figure 73: Pout for 915 MHz Band Operation .....	83
Figure 29: Write Bytes Sequence (ex: 2 bytes).....	37	Figure 74: Pout and IDD at all PA Settings, 869 MHz .....	83
Figure 30: Read Bytes Sequence (ex: 2 bytes).....	38	Figure 75: Pout and IDD at all PA Settings, 915 MHz .....	84
Figure 31: FIFO and Shift Register (SR) .....	38	Figure 76: Pout Stability.....	84
Figure 32: FIFO Threshold IRQ Source Behavior .....	39	Figure 77: 869 MHz Spectral Purity DC-1GHz .....	85
Figure 33: Sync Word Recognition .....	40	Figure 78: 869 MHz Spectral Purity 1-6GHz .....	85
Figure 34: Continuous Mode Conceptual View .....	41	Figure 79: OOK Spectrum - 2kbps.....	86
Figure 35: Tx Processing in Continuous Mode.....	41	Figure 80: OOK Spectrum - 8kbps.....	86
Figure 36: Rx Processing in Continuous Mode.....	42	Figure 81: OOK Spectrum - 16.7kbps .....	86
Figure 37: uC Connections in Continuous Mode.....	43	Figure 82: FSK - 1.56kbps - +/-33 kHz.....	87
Figure 38: Buffered Mode Conceptual View.....	44	Figure 83: FSK - 25 kbps - +/-50 kHz.....	87
Figure 39: Tx processing in Buffered Mode .....	45	Figure 84: FSK - 40 kbps - +/-40 kHz.....	87
Figure 40: Rx Processing in Buffered Mode.....	46	Figure 85: DTS 6dB Bandwidth.....	88
Figure 41: uC Connections in Buffered Mode .....	47	Figure 86: DTS Power Spectral Density.....	88
Figure 42: Packet Mode Conceptual View .....	49	Figure 87: IDD vs. Temp and VDD.....	89
Figure 43: Fixed Length Packet Format.....	50	Figure 88: Package Outline Drawing.....	90
Figure 44: Variable Length Packet Format.....	51	Figure 89: PCB Land Pattern.....	90
Figure 45: CRC Implementation .....	53	Figure 90: Tape & Reel Dimensions .....	91

## Index of Tables

Table 1: Ordering Information.....	1	Table 20: Interrupt Mapping in Buffered Rx and Stby Modes .....	46
Table 2: SX1211 Pinouts.....	7	Table 21: Interrupt Mapping in Buffered Tx Mode .....	46
Table 3: Absolute Maximum Ratings .....	8	Table 22: Relevant Configuration Registers in Buffered Mode ....	47
Table 4: Operating Range .....	8	Table 23: Interrupt Mapping in Rx and Stby in Packet Mode .....	55
Table 5: Power Consumption Specification.....	8	Table 24: Interrupt Mapping in Tx Packet Mode.....	55
Table 6: Frequency Synthesizer Specification .....	9	Table 25: Relevant Configuration Registers in Packet Mode.....	56
Table 7: Transmitter Specification .....	9	Table 26: Registers List.....	58
Table 8: Receiver Specification .....	10	Table 27: MCPParam Register Description .....	58
Table 9: Digital Specification .....	11	Table 28: IRQParam Register Description .....	60
Table 10: MCPParam_Freq_band Setting.....	15	Table 29: RXParam Register Description.....	62
Table 11: PA Rise/Fall Times .....	20	Table 30: SYNCParam Register Description.....	63
Table 12: Operating Modes .....	33	Table 31: TXParam Register Description .....	64
Table 13: Pin Configuration vs. Chip Mode.....	33	Table 32: OSCParam Register Description.....	64
Table 14: Data Operation Mode Selection .....	35	Table 33: PKTPParam Register Description.....	65
Table 15: Config vs. Data SPI Interface Selection .....	36	Table 34: Crystal Resonator Specification .....	66
Table 16: Status of FIFO when Switching Between Different Modes of the Chip .....	39	Table 35: Reference Design BOM .....	74
Table 17: Interrupt Mapping in Continuous Rx Mode .....	42	Table 36: Tools Ordering Information.....	75
Table 18: Interrupt Mapping in Continuous Tx Mode.....	42	Table 37: FSK Rx Filters vs. Bit Rate.....	76
Table 19: Relevant Config. Registers in Continuous Mode .....	43	Table 38: OOK Rx Filters vs. Bit Rate.....	76

## Acronyms

BOM	Bill Of Materials	LO	Local Oscillator
BR	Bit Rate	LSB	Least Significant Bit
BW	Bandwidth	MSB	Most Significant Bit
CCITT	Comité Consultatif International Téléphonique et Télégraphique - ITU	NRZ	Non Return to Zero
CP	Charge Pump	NZIF	Near Zero Intermediate Frequency
CRC	Cyclic Redundancy Check	OOK	On Off Keying
DAC	Digital to Analog Converter	PA	Power Amplifier
DDS	Direct Digital Synthesis	PCB	Printed Circuit Board
DLL	Dynamically Linked Library	PFD	Phase Frequency Detector
ERP	Equivalent Radiated Power	PLL	Phase-Locked Loop
ETSI	European Telecommunications Standards Institute	POR	Power On Reset
FCC	Federal Communications Commission	RBW	Resolution BandWidth
Fdev	Frequency Deviation	RF	Radio Frequency
FIFO	First In First Out	RSSI	Received Signal Strength Indicator
FS	Frequency Synthesizer	Rx	Receiver
FSK	Frequency Shift Keying	SAW	Surface Acoustic Wave
GUI	Graphical User Interface	SPI	Serial Peripheral Interface
IC	Integrated Circuit	SR	Shift Register
ID	IDentifier	Stby	Standby
IF	Intermediate Frequency	Tx	Transmitter
IRQ	Interrupt ReQuest	uC	Microcontroller
ITU	International Telecommunication Union	VCO	Voltage Controlled Oscillator
LFSR	Linear Feedback Shift Register	XO	Crystal Oscillator
LNA	Low Noise Amplifier	XOR	eXclusive OR

This product datasheet contains a detailed description of the SX1211 performance and functionality. Please consult the Semtech website for the latest updates or errata.

## 1. General Description

The SX1211 is a single chip FSK and OOK transceiver capable of operation in the 863-870 MHz and 902-928 MHz license free ISM frequency bands, as well as the 950 - 960 MHz frequency band. It complies with both the relevant European and North American standards, EN 300-220 V2.1.1 (June 2006 release) and FCC Part 15 (10-1-2006 edition). A unique feature of this circuit is its extremely low current consumption in receiver mode of only 3mA (typ). The SX1211 comes in a 5x5 mm TQFN-32 package.

### 1.1. Simplified Block Diagram

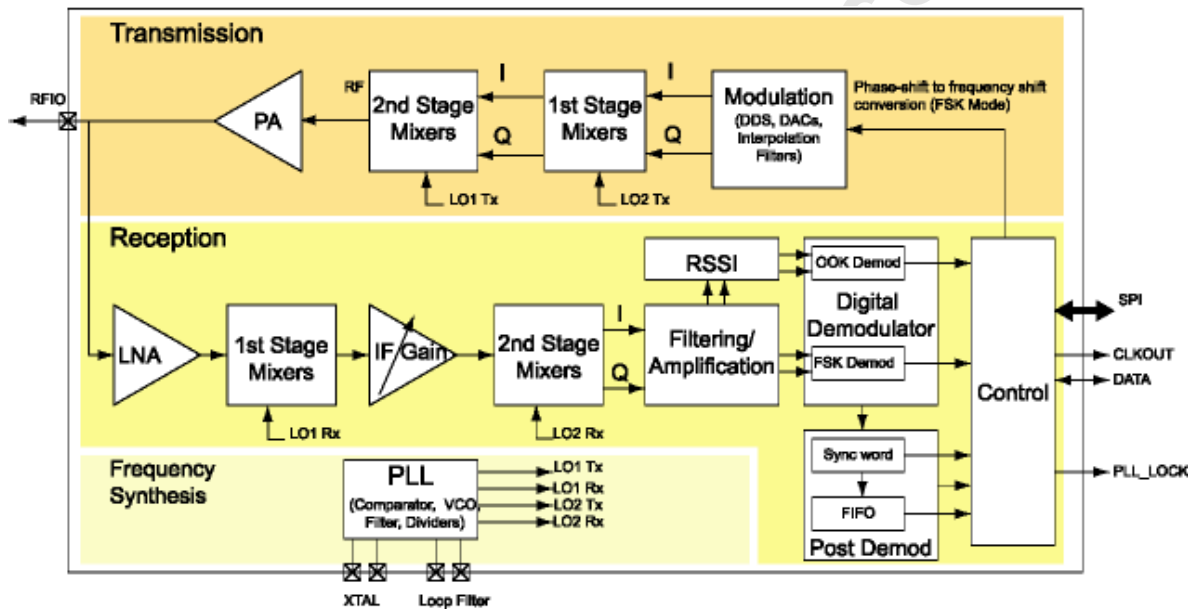

Figure 1: SX1211 Simplified Block Diagram

## 1.2. Pin Diagram

The following diagram shows the pins arrangement of the QFN package, top view.

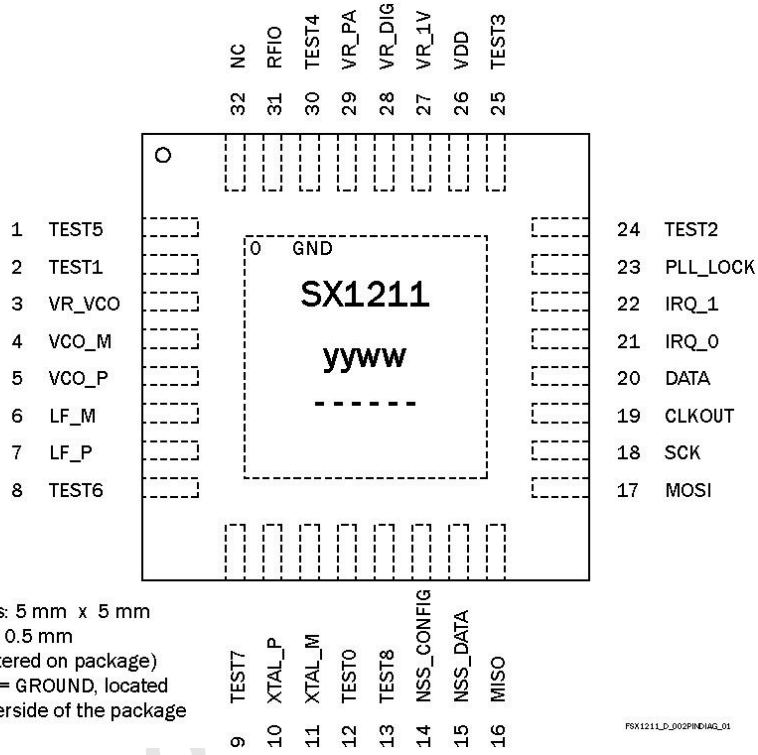

Figure 2: SX1211 Pin Diagram

Notes:

- yyww refers to the date code
- ----- refers to the lot number

### 1.3. Pin Description

Table 2: SX1211 Pinouts

Number	Name	Type	Description
0	GND	I	Exposed ground pad
1	TEST5	I/O	Connect to GND
2	TEST1	I/O	Connect to GND
3	VR_VCO	O	Regulated supply of the VCO
4	VCO_M	I/O	VCO tank
5	VCO_P	I/O	VCO tank
6	LF_M	I/O	PLL loop filter
7	LF_P	I/O	PLL loop filter
8	TEST6	I/O	Connect to GND
9	TEST7	I/O	Connect to GND
10	XTAL_P	I/O	Crystal connection
11	XTAL_M	I/O	Crystal connection
12	TEST0	I	Connect to GND
13	TEST8	I/O	POR. Do not connect if unused
14	NSS_CONFIG	I	SPI CONFIG enable
15	NSS_DATA	I	SPI DATA enable
16	MISO	O	SPI data output
17	MOSI	I	SPI data input
18	SCK	I	SPI clock input
19	CLKOUT	O	Clock output
20	DATA	I/O	NRZ data input and output (Continuous mode)
21	IRQ_0	O	Interrupt output
22	IRQ_1	O	Interrupt output
23	PLL_LOCK	O	PLL lock detection output
24	TEST2	I/O	Connect to GND
25	TEST3	I/O	Connect to GND
26	VDD	I	Supply voltage
27	VR_1V	O	Regulated supply of the analog circuitry
28	VR_DIG	O	Regulated supply of digital circuitry
29	VR_PA	O	Regulated supply of the PA
30	TEST4	I/O	Connect to GND
31	RFIO	I/O	RF input/output
32	NC	-	Connect to GND

Note: pin 13 (Test 8) can be used as an manual reset trigger. See section 7.4.2 for details on its use.



## 2. Electrical Characteristics



### 2.1. ESD Notice

The SX1211 is a high performance radio frequency device. It satisfies:

- Class 2 of the JEDEC standard JESD22-A114-B (Human Body Model), except on pins 3-4-5-27-28-29-31 where it satisfies Class 1A.
- Class III of the JEDEC standard JESD22-C101C (Charged Device Model) on all pins.

It should thus be handled with all the necessary ESD precautions to avoid any permanent damage.

### 2.2. Absolute Maximum Ratings

Stresses above the values listed below may cause permanent device failure. Exposure to absolute maximum ratings for extended periods may affect device reliability.

Table 3: Absolute Maximum Ratings

Symbol	Description	Min	Max	Unit
VDDmr	Supply voltage	-0.3	3.7	V
Tmr	Storage temperature	-55	125	°C
Pmr	Input level	-	0	dBm

### 2.3. Operating Range

Table 4: Operating Range

Symbol	Description	Min	Max	Unit
VDDop	Supply Voltage	2.1	3.6	V
Trop	Temperature	-40	+85	°C
ML	Input Level	-	0	dBm

### 2.4. Chip Specification

Conditions: Temp = 25 °C, VDD = 3.3 V, crystal frequency = 12.8 MHz, carrier frequency = 869 or 915 MHz, modulation FSK, data rate = 25 kb/s, Fdev = 50 kHz, fc = 100 kHz, unless otherwise specified.

#### 2.4.1. Power Consumption

Table 5: Power Consumption Specification

Symbol	Description	Conditions	Min	Typ	Max	Unit
IDDSL	Supply current, Sleep mode		-	0.1	2	µA
IDDST	Supply current in standby mode, CLKOUT disabled	Crystal oscillator running <sup>(2)</sup>	-	65	80	µA
IDDFS	Supply current in FS mode	Frequency synthesizer running	-	1.3	1.7	mA
IDDR	Supply current in Rx mode		-	3.0	3.5	mA
IDDT	Supply current in Tx mode	Output power = +10 dBm	-	25	30	mA
		Output power = 1dBm <sup>(1)</sup>	-	16	21	mA

<sup>(1)</sup> Guaranteed by design and characterization

<sup>(2)</sup> Crystal Load=10pF, C0=2.5pF, Rm=15 Ohms



## 2.4.2. Frequency Synthesis

Table 6: Frequency Synthesizer Specification

Symbol	Description	Conditions	Min	Typ	Max	Unit
FR	Frequency ranges	Programmable but requires specific BOM	863	-	870	MHz
			902	-	928	MHz
			950	-	960	MHz
BR_F	Bit rate (FSK)	NRZ	1.56	-	200	Kb/s
BR_O	Bit rate (OOK)	NRZ	1.56	-	32	Kb/s
FDA	Frequency deviation (FSK)		33	50	200	kHz
XTAL	Crystal oscillator frequency		9	12.8	15	MHz
FSTEP	Frequency synthesizer step	Variable, depending on the frequency.	-	2	-	kHz
TS_OSC	Oscillator wake-up time	From Sleep mode <sup>(1)</sup>	-	1.5	5	ms
TS_FS	Frequency synthesizer wake-up time at most 10 kHz away from the target	From Stby mode	-	500	800	µs
TS_HOP	Frequency synthesizer hop time at most 10 kHz away from the target	200 kHz step	-	180	-	µs
		1 MHz step	-	200	-	µs
		5 MHz step	-	250	-	µs
		7 MHz step	-	260	-	µs
		12 MHz step	-	290	-	µs
		20 MHz step	-	320	-	µs
		27 MHz step	-	340	-	µs

<sup>(1)</sup> Guaranteed by design and characterization

## 2.4.3. Transmitter

Table 7: Transmitter Specification

Symbol	Description	Conditions	Min	Typ	Max	Unit
RFOP	RF output power, programmable with 8 steps of typ. 3dB	Maximum power setting	-	+12.5	-	dBm
		Minimum power setting	-	-8.5	-	dBm
PN	Phase noise	Measured with a 600 kHz offset, at the transmitter output.	-	-112	-	dBc/Hz
SPT	Transmitted spurious	At any offset between 200 kHz and 600 kHz, unmodulated carrier, Fdev = 50 kHz.	-	-	-47	dBc
TS_TR <sup>(1)</sup>	Transmitter wake-up time	From FS to Tx ready.	-	120	500	µs
TS_TR2 <sup>(1)</sup>	Transmitter wake-up time	From Stby to Tx ready.	-	600	900	µs

<sup>(1)</sup> Guaranteed by design and characterization

### 2.4.4. Receiver

On the following table,  $f_c$  and  $f_o$  describe the bandwidth of the active channel filters as described in section 3.4.4.2. All sensitivities are measured receiving a PN15 sequence, for a BER of 0.1.%

Table 8: Receiver Specification

Symbol	Description	Conditions	Min	Typ	Max	Unit
RFS_F	Sensitivity (FSK)	869 MHz, BR=25 kb/s, Fdev=50 kHz, $f_c=100$ kHz	-	-107	-	dBm
		869 MHz, BR=66.7 kb/s, Fdev=100 kHz, $f_c=200$ kHz	-	-103	-	dBm
		915 MHz, BR=25 kb/s, Fdev=50 kHz, $f_c=100$ kHz	-	-105	-	dBm
		915 MHz, BR = 66.7 kb/s, Fdev=100 kHz, $f_c=200$ kHz	-	-101	-	dBm
RFS_O	Sensitivity (OOK)	869 MHz, 2kb/s NRZ $f_c-f_o=50$ kHz, $f_o=50$ kHz	-	-113	-	dBm
		869 MHz, 16.7 kb/s NRZ $f_c-f_o=100$ kHz, $f_o=100$ kHz	-	-106	-	dBm
		915 MHz, 2kb/s NRZ $f_c-f_o=50$ kHz, $f_o=50$ kHz	-	-111	-	dBm
		915 MHz, 16.7 kb/s NRZ $f_c-f_o=100$ kHz, $f_o=100$ kHz	-	-105	-	dBm
CCR	Co-channel rejection	Modulation as wanted signal	-	-12	-	dBc
ACR	Adjacent channel rejection	Offset = 300 kHz, unwanted tone is not modulated	-	27	-	dB
		Offset = 600 kHz, unwanted tone is not modulated	-	52	-	dB
		Offset = 1.2 MHz, unwanted tone is not modulated	-	57	-	dB
BI	Blocking immunity	Offset = 1 MHz, unmodulated	-	-48	-	dBm
		Offset = 2 MHz, unmodulated, no SAW	-	-37	-	dBm
		Offset = 10 MHz, unmodulated, no SAW	-	-33	-	dBm
RXBW_F <sup>(1,2)</sup>	Receiver bandwidth in FSK mode	Single side BW Polyphase Off	50	-	250	kHz
RXBW_O <sup>(1,2)</sup>	Receiver bandwidth in OOK mode	Single side BW Polyphase On	50	-	400	kHz
IIP3	Input 3 <sup>rd</sup> order intercept point	Interferers at 1MHz and 1.950 MHz offset	-	-28	-	dBm
TS_RE <sup>(1)</sup>	Receiver wake-up time	From FS to Rx ready	-	280	500	µs
TS_RE2 <sup>(1)</sup>	Receiver wake-up time	From Stby to Rx ready	-	600	900	µs
TS_RE_HOP	Receiver hop time from Rx ready to Rx ready with a frequency hop	200 kHz step	-	400	-	µs
		1MHz step	-	400	-	µs
		5MHz step	-	460	-	µs
		7MHz step	-	480	-	µs
		12MHz step	-	520	-	µs
		20MHz step	-	550	-	µs
		27MHz step	-	600	-	µs
TS_RSSI	RSSI sampling time	From Rx ready	-	-	1/Fdev	s
DR_RSSI	RSSI dynamic Range	Ranging from sensitivity	-	70	-	dB

<sup>(1)</sup> Guaranteed by design and characterization

<sup>(2)</sup> This reflects the whole receiver bandwidth, as described in sections 3.4.4.1 and 3.4.4.2

### 2.4.5. Digital Specification

Conditions: Temp = 25 °C, VDD = 3.3 V, crystal frequency = 12.8 MHz, unless otherwise specified.

Table 9: Digital Specification

Symbol	Description	Conditions	Min	Typ	Max	Unit
VIH	Digital input level high		0.8*VDD	-	-	V
VIL	Digital input level low		-	-	0.2*VDD	V
VOH	Digital output level high	I <sub>max</sub> =1mA	0.9*VDD	-	-	V
VOL	Digital output level low	I <sub>max</sub> =-1mA	-	-	0.1*VDD	V
SCK_CONFIG	SPI Config. clock frequency		-	-	6	MHz
SCK_DATA	SPI Data clock frequency		-	-	1	MHz
T_DATA	DATA hold and setup time		2	-	-	µs
T_MOSI_C	MOSI setup time for SPI Config.		250	-	-	ns
T_MOSI_D	MOSI setup time for SPI Data.		312	-	-	ns
T_NSSC_L	NSS_CONFIG low to SCK rising edge. SCK falling edge to NSS_CONFIG high.		500	-	-	ns
T_NSSD_L	NSS_DATA low to SCK rising edge. SCK falling edge to NSS_DATA high.		625	-	-	ns
T_NSSC_H	NSS_CONFIG rising to falling edge.		500	-	-	ns
T_NSSD_H	NSS_DATA rising to falling edge.		625	-	-	ns

Note: on pin 10 (XTAL\_P) and 11 (XTAL\_N), maximum voltages of 1.8V can be applied.

### 3. Architecture Description

This section describes in depth the architecture of this ultra low-power transceiver:

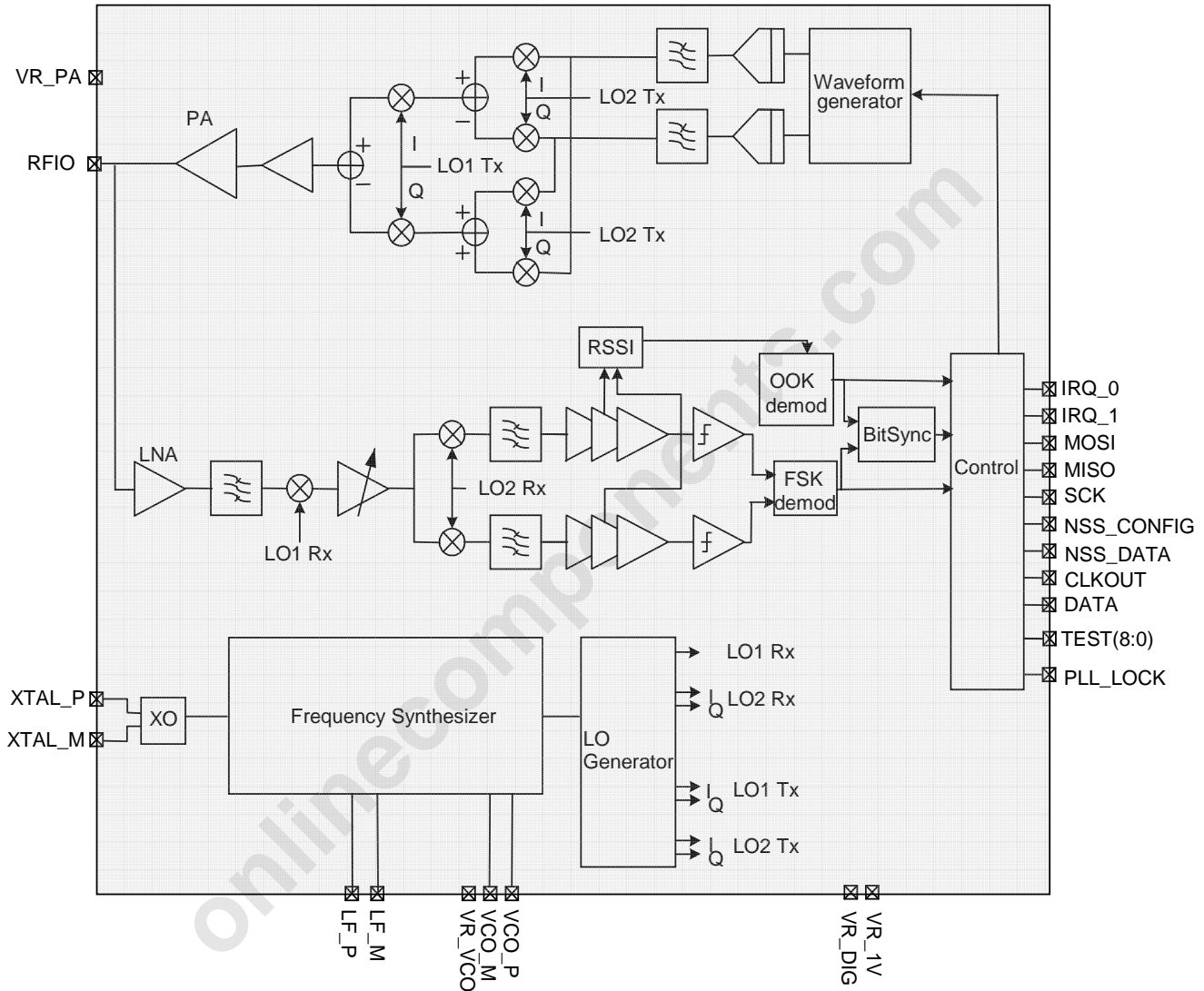

Figure 3: SX1211 Detailed Block Diagram

#### 3.1. Power Supply Strategy

To provide stable sensitivity and linearity characteristics over a wide supply range, the SX1211 is internally regulated. This internal regulated power supply structure is described below:

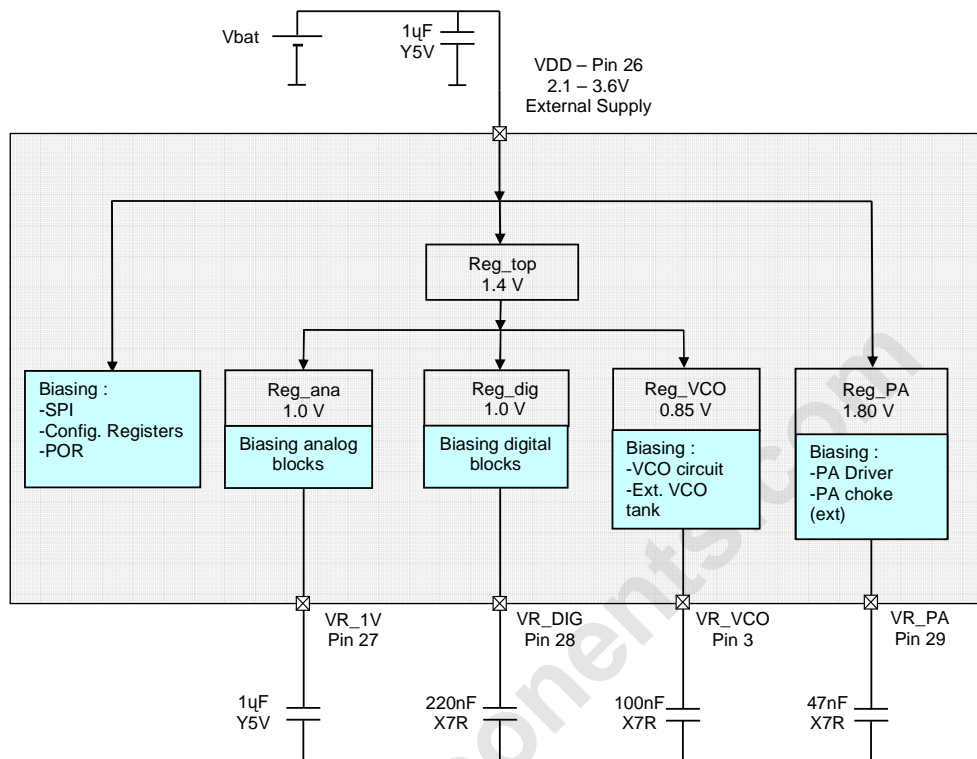

Figure 4: Power Supply Breakdown

To ensure correct operation of the regulator circuit, the decoupling capacitor connection shown in Figure 4 is required. These decoupling components are recommended for any design.

## 3.2. Frequency Synthesis Description

The frequency synthesizer of the SX1211 is a fully integrated integer-N type PLL. The PLL circuit requires only five external components for the PLL loop filter and the VCO tank circuit.

### 3.2.1. Reference Oscillator

The SX1211 embeds a crystal oscillator, which provides the reference frequency for the PLL. The recommended crystal specification is given in section 7.1.

### 3.2.2. CLKOUT Output

The reference frequency, or a sub-multiple of it, can be provided on CLKOUT (pin 19) by activating the bit OSCParam\_Clkout\_on. The division ratio is programmed through bits OSCParam\_Clkout\_freq. The two applications of the CLKOUT output are:

- To provide a clock output for a companion uC, thus saving the cost of an additional oscillator. CLKOUT can be made available in any operation mode, except Sleep mode, and is automatically enabled at power-up.
- To provide an oscillator reference output. Measurement of the CLKOUT signal enables simple software trimming of the initial crystal tolerance.

Note: To minimize the current consumption of the SX1211, ensure that the CLKOUT signal is disabled when unused.

### 3.2.3. PLL Architecture

The crystal oscillator (XO) forms the reference oscillator of an Integer-N Phase Locked Loop (PLL), whose operation is discussed in the following section. Figure 5 shows a block schematic of the SX1211 PLL. Here the crystal reference frequency and the software controlled dividers R, P and S determine the output frequency of the PLL.

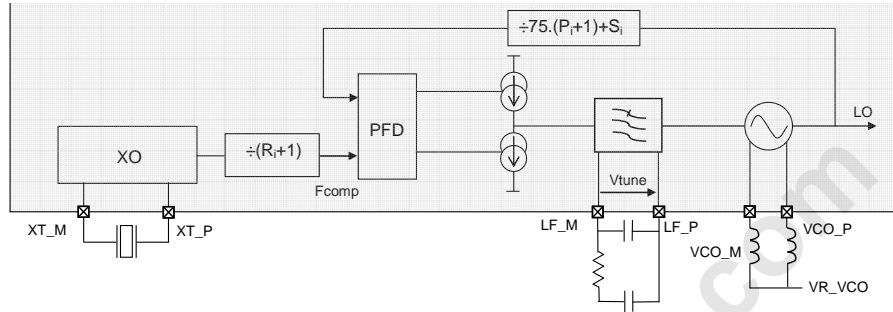

Figure 5: Frequency Synthesizer Description

The VCO tank inductors are connected on an external differential input. Similarly, the loop filter is also located externally. However, there is an internal 8pF capacitance at VCO input that should be subtracted from the desired loop filter capacitance.

The output signal of the VCO is used as the input to the local oscillator (LO) generator stage, illustrated in Figure 6. The VCO frequency is subdivided and used in a series of up (down) conversions for transmission (reception).

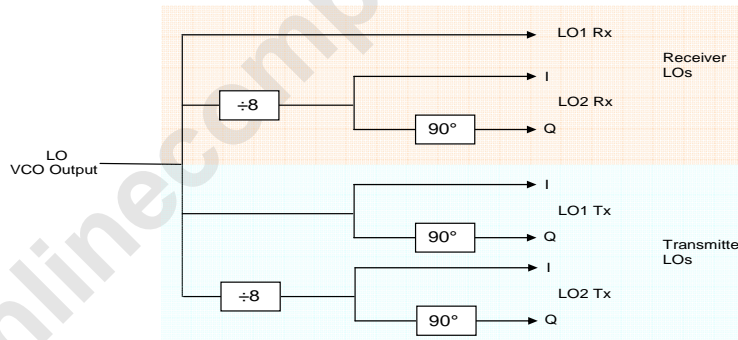

Figure 6: LO Generator

### 3.2.4. PLL Tradeoffs

With an integer-N PLL architecture, the following criterion must be met to ensure correct operation:

- The comparison frequency,  $F_{comp}$ , of the Phase Frequency Detector (PFD) input must remain higher than six times the PLL bandwidth (PLLBW) to guarantee loop stability and to reject harmonics of the comparison frequency  $F_{comp}$ . This is expressed in the inequality:

$$PLLBW \leq \frac{F_{comp}}{6}$$

- However the PLLBW has to be sufficiently high to allow adequate PLL lock times
- Because the divider ration R determines  $F_{comp}$ , it should be set close to 119, leading to  $F_{comp} \approx 100$  kHz which will ensure suitable PLL stability and speed.

With the recommended Bill Of Materials (BOM) of the reference design of section 7.5.3, the PLL prototype is the following:

- $64 \leq R \leq 169$
- $S < P+1$
- PLLBW = 15 kHz nominal
- Startup times and reference frequency spurs as specified.

### 3.2.5. Voltage Controlled Oscillator

The integrated VCO requires only two external tank circuit inductors. As the input is differential, the two inductors should have the same nominal value. The performance of these components is important for both the phase noise and the power consumption of the PLL. It is recommended that a pair of high Q factor inductors is selected. These should be mounted orthogonally to other inductors (in particular the PA choke) to reduce spurious coupling between the PA and VCO. In addition, such measures may reduce radiated pulling effects and undesirable transient behavior, thus minimizing spectral occupancy. Note that ensuring a symmetrical layout of the VCO inductors will further improve PLL spectral purity.

For best performance wound type inductors, with tight tolerance, should be used as described in section 7.5.3.

#### 3.2.5.1. SW Settings of the VCO

To guarantee the optimum operation of the VCO over the SX1211's frequency and temperature ranges, the following settings should be programmed into the SX1211:

Target channel (MHz)	863-870	902-915	915-928	950-960
Freq_band	10	00	01	10

Table 10: MCPParam\_Freq\_band Setting

#### 3.2.5.2. Trimming the VCO Tank by Hardware and Software

To ensure that the frequency band of operation may be accurately addressed by the R, P and S dividers of the synthesizer, it is necessary to ensure that the VCO is correctly centered. Note that for the reference design (see section 7.5) no centering is necessary. However, any deviation from the reference design may require the optimization procedure, outlined below, to be implemented. This procedure is simplified thanks to the built-in VCO trimming feature which is controlled over the SPI interface. This tuning does not require any RF test equipment, and can be achieved by simply measuring  $V_{tune}$ , the voltage between pins 6 (LFM) and 7 (LFP).

The VCO is centered if the voltage is within the range:

$$50 \leq V_{tune}(mV) \leq 150$$

Note that this measurement should be conducted when in transmit mode at the center frequency of the desired band (for example ~867 MHz in the 863-870 MHz band), with the appropriate MCPParam\_Freq\_band setting.

If this inequality is not satisfied then adjust the MCPParam\_VCO\_trim bits from 00 whilst monitoring  $V_{tune}$ . This allows the VCO voltage to be trimmed in + 60 mV increments. Should the desired voltage range be inaccessible, the voltage may be adjusted further by changing the tank circuit inductance value. Note that an increase in inductance will result in an increase  $V_{tune}$ .



Note for mass production: The VCO capacitance is piece to piece dependant. As such, the optimization proposed above should be verified on several prototypes, to ensure that the population is centered on 100 mV.

### 3.2.6. PLL Loop Filter

To adequately reject spurious components arising from the comparison frequency  $F_{comp}$ , an external 2<sup>nd</sup> order loop filter is employed.

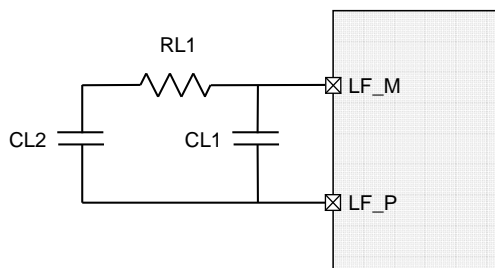

Figure 7: Loop Filter

Following the recommendations made in section 3.2.4, the loop filter proposed in the reference design's bill of material on section 7.5.3 should be used. The loop filter settings are frequency band independent and are hence relevant to all implementations of the SX1211.

### 3.2.7. PLL Lock Detection Indicator

The SX1211 also features a PLL lock detect indicator. This is useful for optimizing power consumption, by adjusting the synthesizer wake up time (TS\_FS), since the PLL startup time is lower than specified under nominal conditions. The lock status can be read on bit IRQParam\_PLL\_lock, and must be cleared by writing a "1" to this same register. In addition, the lock status can be reflected in pin 23 PLL\_LOCK, by setting the bit IRQParam\_Enable\_lock\_detect.

### 3.2.8. Frequency Calculation

As shown in Figure 5 the PLL structure comprises three different dividers, R, P and S, which set the output frequency through the LO. A second set of dividers is also available to allow rapid switching between a pair of frequencies: R1/P1/S1 and R2/P2/S2. These six dividers are programmed by six bytes of the register MCPParam from addresses 6 to 11.

#### 3.2.8.1. FSK Mode

The following formula gives the relationship between the local oscillator, and R, P and S values, when using FSK modulation.

$$F_{rf}, f_{sk} = \frac{9}{8} F_{lo}$$

$$F_{rf}, f_{sk} = \frac{9}{8} \frac{F_{xtal}}{R+1} [75(P+1) + S]$$

#### 3.2.8.2. OOK Mode

Due to the manner in which the baseband OOK symbols are generated, the signal is always offset by the FSK frequency deviation (Fdev - as programmed in MCPParam\_Freq\_dev). Hence, the center of the transmitted OOK signal is:

$$F_{rf,ook,tx} = \frac{9}{8} F_{lo} - F_{dev}$$

$$F_{rf,ook,tx} = \frac{9}{8} \frac{F_{xtal}}{R+1} [75(P+1) + S] - F_{dev}$$

Consequently, in receive mode, due to the low intermediate frequency (Low-IF) architecture of the SX1211 the frequency should be configured so as to ensure the correct low-IF receiver baseband center frequency, IF2.

$$F_{rf,ook,rx} = \frac{9}{8} F_{lo} - IF2$$

$$F_{rf,ook,rx} = \frac{9}{8} \frac{F_{xtal}}{R+1} [75(P+1) + S] - IF2$$

Note that from Section 3.4.4, it is recommended that IF2 be set to 100 kHz.

onlinecomponents.com

### 3.3. Transmitter Description

The SX1211 is set to transmit mode when MCPParam\_Chip\_mode = 100.

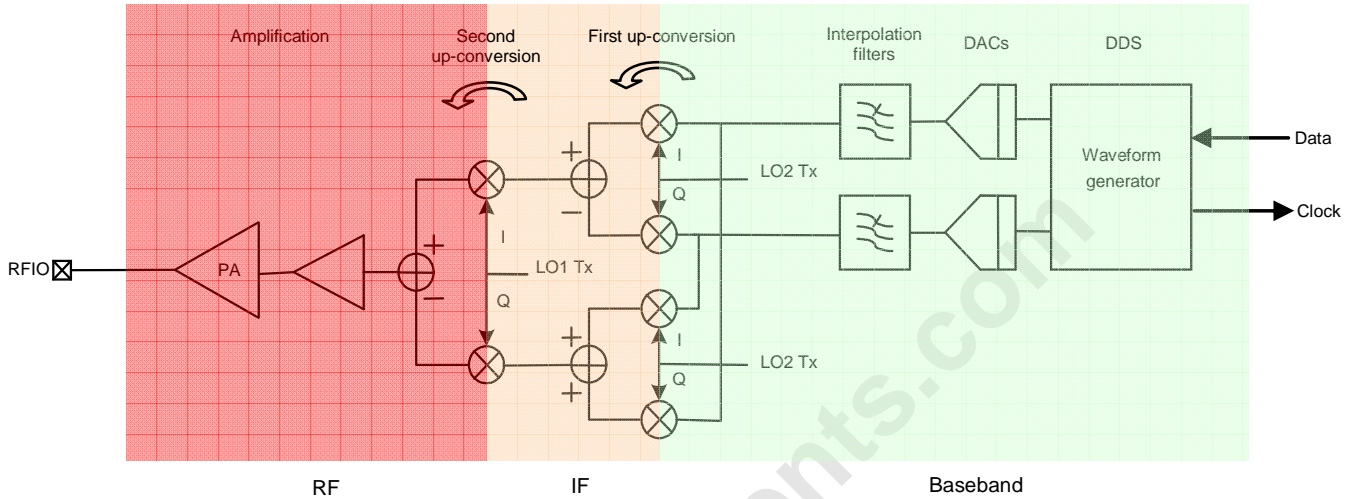

Figure 8: Transmitter Architecture

#### 3.3.1. Architecture Description

The baseband I and Q signals are digitally generated by a DDS whose digital to analog converters (DAC) followed by two anti-aliasing low-pass filters transform the digital signal into analog in-phase (I) and quadrature (Q) components whose frequency is the selected frequency deviation (Fdev).

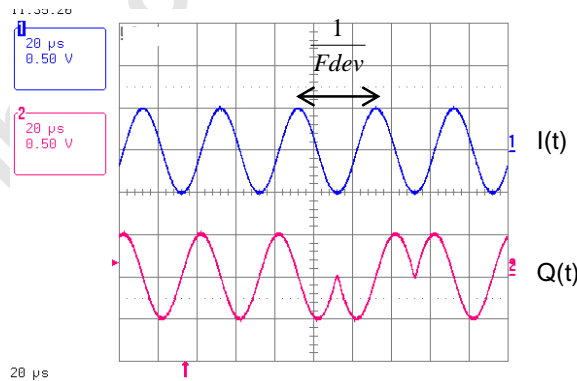

Figure 9: I(t), Q(t) Overview

In FSK mode, the relative phase of I and Q is switched by the input data between  $-90^\circ$  and  $+90^\circ$  with continuous phase. The modulation is therefore performed at this initial stage, since the information contained in the phase difference will be converted into a frequency shift when the I and Q signals are up-converted in the first mixer stage. This first up-conversion stage is duplicated to enhance image rejection. The FSK convention is such that:

$$DATA = '1' \Rightarrow Frf + Fdev$$

$$DATA = '0' \Rightarrow Frf - Fdev$$

In OOK mode, the phase difference between the I and Q channels is kept constant (independent of the transmitted data). Thus, the first stage of up-conversion creates a fixed frequency signal at the low  $IF = F_{dev}$  (This explains why the transmitted OOK spectrum is offset by  $F_{dev}$ ).

OOK Modulation is accomplished by switching on and off the PA and PA regulator stages. By convention:

$$DATA = '1' \Rightarrow PA_{on}$$

$$DATA = '0' \Rightarrow PA_{off}$$

After the interpolation filters, a set of four mixers combines the I and Q signals and converts them into a pair of complex signals at the second intermediate frequency, equal to 1/8 of the LO frequency, or 1/9 of the RF frequency. These two new I and Q signals are then combined and up-converted to the final RF frequency by two quadrature mixers fed by the LO signal. The signal is pre-amplified, and then the transmitter output is driven by a final power amplifier stage.

### 3.3.2. Bit Rate Setting

In Continuous transmit mode, setting the Bit Rate is useful to determine the frequency of DCLK. As explained in section 5.3.2, DCLK will trigger an interrupt on the uC each time a new bit has to be transmitted.

$$BR = \frac{F_{XTAL}}{64 * [1 + val(MCParam\_BR)]}$$

### 3.3.3. Alternative Settings

Bit rate, frequency deviation and TX interpolation filter settings are a function of the reference oscillator crystal frequency,  $F_{XTAL}$ . Settings other than those programmable with a 12.8 MHz crystal can be obtained by selection of the correct reference oscillator frequency. Please contact your local Semtech representative for further details.

### 3.3.4. Fdev Setting in FSK Mode

The frequency deviation,  $F_{dev}$ , of the FSK transmitter is programmed through bits  $MCParam\_Freq\_dev$ :

$$F_{dev} = \frac{F_{XTAL}}{32 * [1 + val(MCParam\_Freq\_dev)]}$$

For correct operation the modulation index  $\beta$  should be such that:

$$\beta = 2 * \frac{F_{dev}}{BR} \geq 2$$

It should be noted that for communications between a pair of SX1211s, that  $F_{dev}$  should be at least 33 kHz to ensure a correct operation on the receiver side.

### 3.3.5. Fdev Setting in OOK Mode

$F_{dev}$  has no physical meaning in OOK transmit mode. However, as has been shown - due to the DDS baseband signal generation, the OOK signal is always offset by " $-F_{dev}$ " (see formulas in section 3.2.8). It is suggested that  $F_{dev}$  retains its default value of 100 kHz in OOK mode.

### 3.3.6. Interpolation Filter

After digital to analog conversion, both I and Q signals are smoothed by interpolation filters. This block low-pass filters the digitally generated signal, and prevents the alias signals from entering the modulators. Its bandwidth can be programmed with the register RXPParam\_InterpFiltTx, and should be set to:

$$BW \cong 3 * \left[ Fdev + \frac{BR}{2} \right]$$

Where Fdev is the programmed frequency deviation as set in MCPParam\_Freq\_dev, and BR is the physical Bit Rate of transmission.

Notes:

- Low interpolation filter bandwidth will attenuate the baseband I/Q signals thus reducing the power of the FSK signal. Conversely, excessive bandwidth will degrade spectral purity.
- For the wideband FSK modulation, for example when operating in DTS mode, the recommended filter setting can not be reached. However, the impact upon spectral purity will be negligible, due to the already wideband channel.

### 3.3.7. Power Amplifier

The Power Amplifier (PA) integrated in the SX1211 operates under a regulated voltage supply of 1.8 V. The external PA choke inductor is biased by an internal regulator output made available on pin 29 (VR\_PA). Thanks to these features, the PA output power is consistent over the power supply range. This is important for mobile applications where this allows both predictable RF performance and battery life.

#### 3.3.7.1. Rise and Fall Times Control

In OOK mode, the PA ramp times can be accurately controlled through the MCPParam\_PA\_ramp register. Those bits directly control the slew rate of VR\_PA output (pin 29).

Table 11: PA Rise/Fall Times

MCPParam_PA_ramp	t <sub>VR_PA</sub>	t <sub>PA_OUT</sub> (rise / fall)
00	3 us	2.5 / 2 us
01	8.5 us	5 / 3 us
10	15 us	10 / 6 us
11	23 us	20 / 10 us

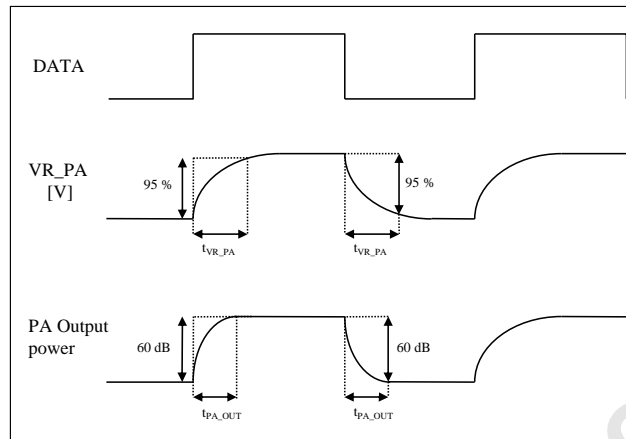

Figure 10: PA Control

### 3.3.7.2. Optimum Load Impedance

As the PA and the LNA front-ends in the SX1211 share the same Input/Output pin, they are internally matched to approximately 50  $\Omega$ .

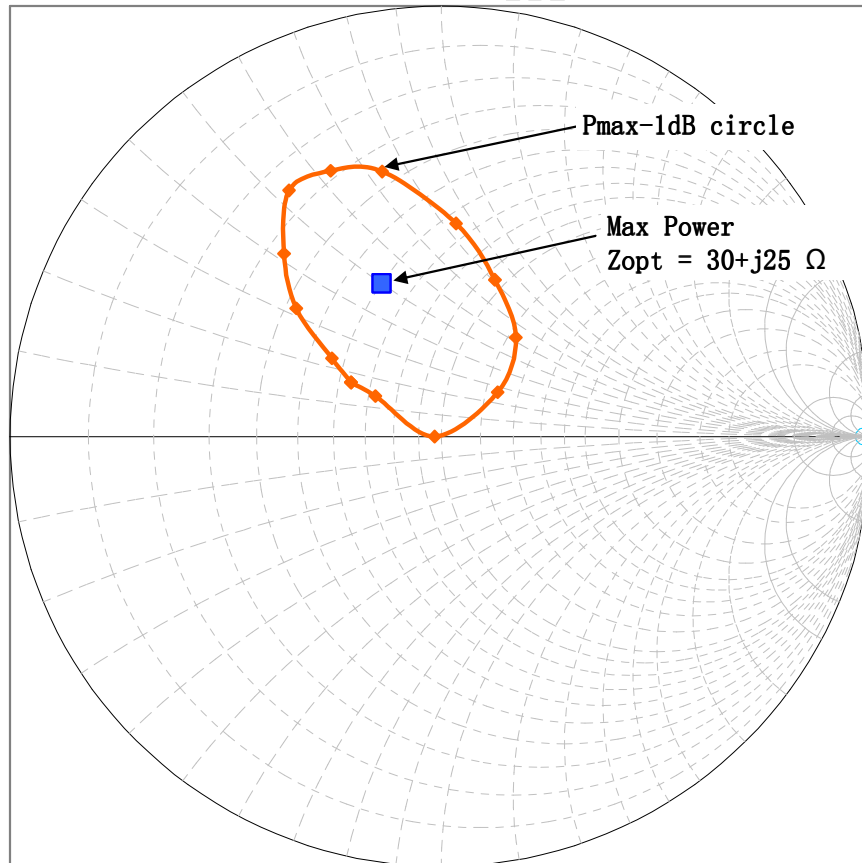

Figure 11: Optimal Load Impedance Chart

Please refer to the reference design section for an optimized PA load setting.

### 3.3.7.3. Suggested PA Biasing and Matching

The recommended PA bias and matching circuit is illustrated below:

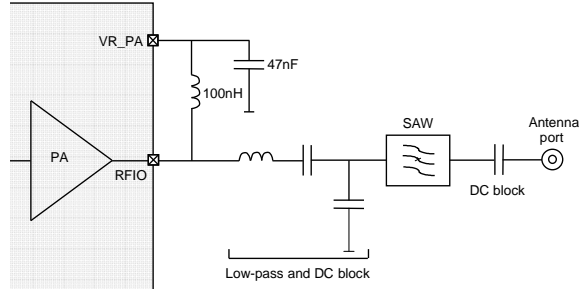

Figure 12: Recommended PA Biasing and Output Matching

Please refer to section 7.5.3 of this document for the optimized matching arrangement for each frequency band.

### 3.3.8. Common Input and Output Front-End

The receiver and the transmitter share the same RFIO pin (pin 31). Figure 13 below shows the configuration of the common RF front-end.

- In transmit mode, the PA and the PA regulator are active, with the voltage on the VR\_PA pin equal to the nominal voltage of the regulator (1.8 V). The external inductance is used to bias the PA.
- In receive mode, both PA and PA regulator are off and VR\_PA is tied to ground. The external inductance LT1 is then used to bias the LNA.

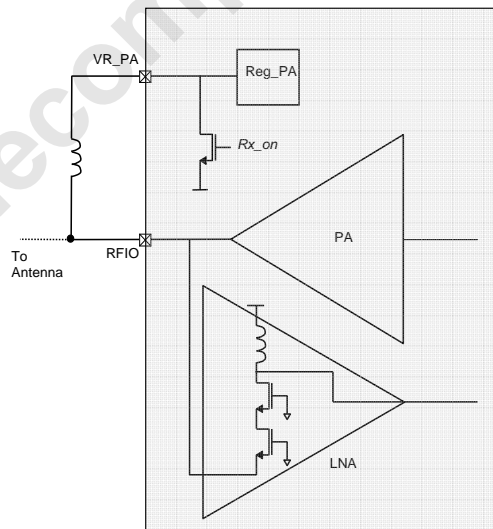

Figure 13: Front-end Description



### 3.4. Receiver Description

The SX1211 is set to receive mode when MCPParam\_Chip\_mode = 011.

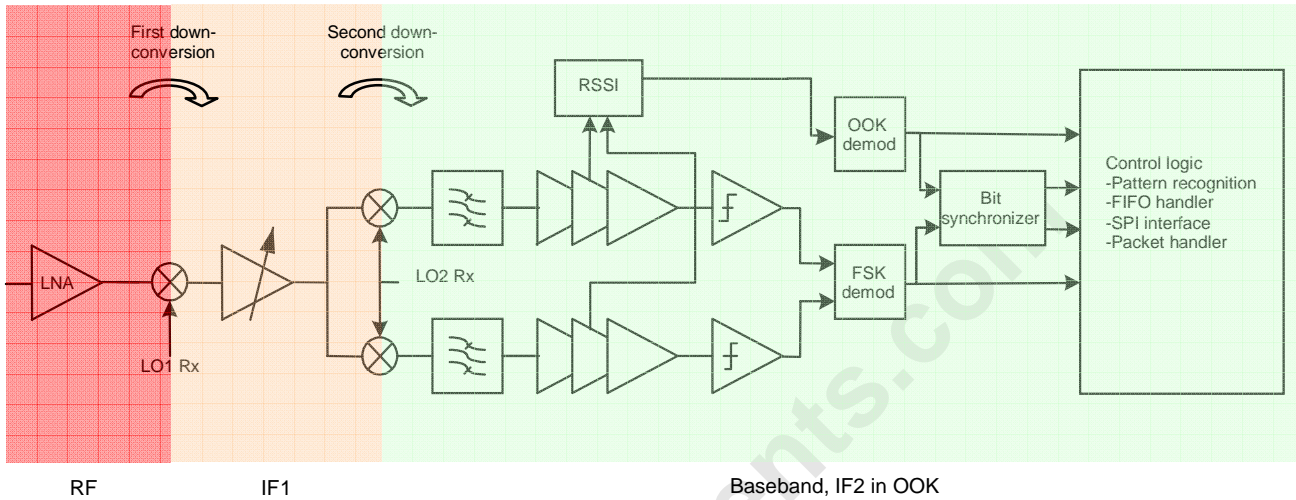

Figure 14: Receiver Architecture

#### 3.4.1. Architecture

The SX1211 receiver employs a super-heterodyne architecture. Here, the first IF is 1/9<sup>th</sup> of the RF frequency (approximately 100MHz). The second down-conversion down-converts the I and Q signals to base band in the case of the FSK receiver (Zero IF) and to a low-IF (IF2) for the OOK receiver.

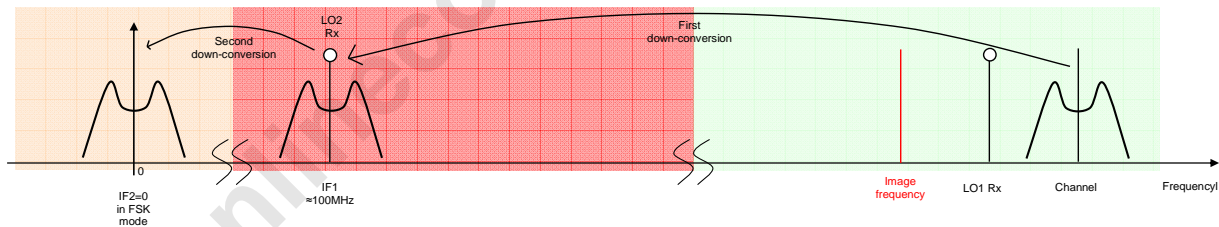

Figure 15: FSK Receiver Setting

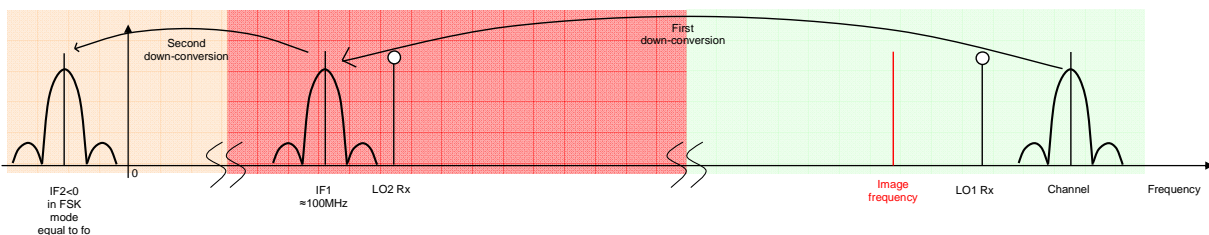

Figure 16: OOK Receiver Setting

After the second down-conversion stage, the received signal is channel-select filtered and amplified to a level adequate for demodulation. Both FSK and OOK demodulation are available. Finally, an optional Bit Synchronizer (BitSync) is provided, to be supply a synchronous clock and data stream to a companion uC in Continuous mode,

or to fill the FIFO buffers with glitch-free data in Buffered mode. The operation of the receiver is now described in detail.

Note: Image rejection is achieved by the SAW filter.

### 3.4.2. LNA and First Mixer

In receive mode, the RFIO pin is connected to a fixed gain, common-gate, Low Noise Amplifier (LNA). The performance of this amplifier is such that the Noise Figure (NF) of the receiver can be estimated to be ≈7 dB.

### 3.4.3. IF Gain and Second I/Q Mixer

Following the LNA and first down-conversion, there is an IF amplifier whose gain can be programmed from -13.5 dB to 0 dB in 4.5 dB steps, via the register MCPParam\_IF\_gain. The default setting corresponds to 0 dB gain, but lower values can be used to increase the RSSI dynamic range. Refer to section 3.4.7 for additional information.

### 3.4.4. Channel Filters

The second mixer stages are followed by the channel select filters. The channel select filters have a strong influence on the noise bandwidth and selectivity of the receiver and hence its sensitivity. Each filter comprises a passive and active section.

#### 3.4.4.1. Passive Filter

Each channel select filter features a passive second-order RC filter, with a bandwidth programmable through the bits RXParam\_PassiveFilt. As the wider of the two filters, its effect on the sensitivity is negligible, but its bandwidth has to be setup instead to optimize blocking immunity. The value entered into this register sets the single side bandwidth of this filter. For optimum performance it should be set to 3 to 4 times the cutoff frequency of the active Butterworth (or polyphase) filter described in the next section.

$$3 * F_{C_{ButterFilt}} \leq BW_{passive,filter} \leq 4 * F_{C_{ButterFilt}}$$

#### 3.4.4.2. Active Filter

The 'fine' channel selection is performed by an active, third-order, Butterworth filter, which acts as a low-pass filter for the zero-IF configuration (FSK), or a complex polyphase filter for the Low-IF (OOK) configuration. The RXParam\_PolyFilt\_on bit enables/disables the polyphase filter.

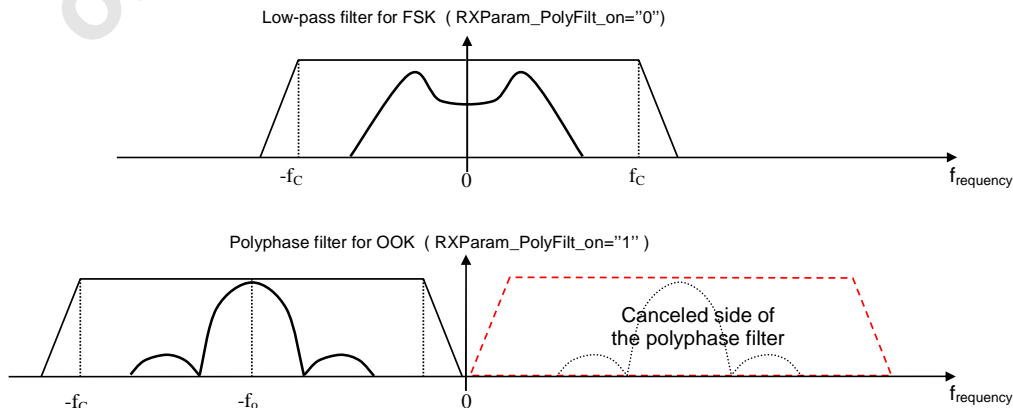

Figure 17: Active Channel Filter Description

As can be seen from Figure 17, the required bandwidth of this filter varies between the two demodulation modes.

- FSK mode: The 99% energy bandwidth of an FSK modulated signal is approximated to be:

$$BW_{99\%,FSK} = 2 * \left[ Fdev + \frac{BR}{2} \right]$$

The bits RXParam\_ButterFilt set  $f_c$ , the cutoff frequency of the filter. As we are in a Zero-IF configuration, the FSK lobes are centered around the virtual "DC" frequency. The choice of  $f_c$  should be such that the modulated signal falls in the filter bandwidth, anticipating the Local Oscillator frequency drift over the operating temperature and aging of the device:

$$2 * f_c > BW_{99\%,FSK} + LO_{drifts}$$

Please refer to the charts in section 3.4.5 for an accurate overview of the filter bandwidth vs. setting.

- OOK mode: The 99% energy bandwidth of an OOK modulated signal is approximated to be:

$$BW_{99\%,OOK} = \frac{2}{Tbit} = 2.BR$$

The bits RXParam\_PolypFilt\_center set  $f_o$ , the center frequency of the polyphase filter when activated.  $f_o$  should always be chosen to be equal to the low Intermediate Frequency of the receiver (IF2). This is why, in the GUI described in section 7.2.1 of this document, the low IF frequency of the OOK receiver denoted IF2 has been replaced by  $f_o$ .

The following setting is recommended:

$$f_o = 100kHz$$

$$RXParam\_PolypFilt = "0011"$$

The value stored in RXParam\_ButterFilt determines  $f_c$ , the filter cut-off frequency. So the user should set  $f_c$  according to:

$$2 * (f_c - f_o) > BW_{99\%,OOK} + LO_{drifts}$$

Again,  $f_c$  as a function of RXParam\_ButterFilt is given in the section 3.4.6.

### 3.4.5. Channel Filters Setting in FSK Mode

$F_c$ , the 3dB cutoff frequency of the Butterworth filter used in FSK reception, is programmed through the bit RXParam\_ButterFilt. However, the whole receiver chain influences this cutoff frequency. Thus the channel select and resultant filter bandwidths are summarized in the following chart:

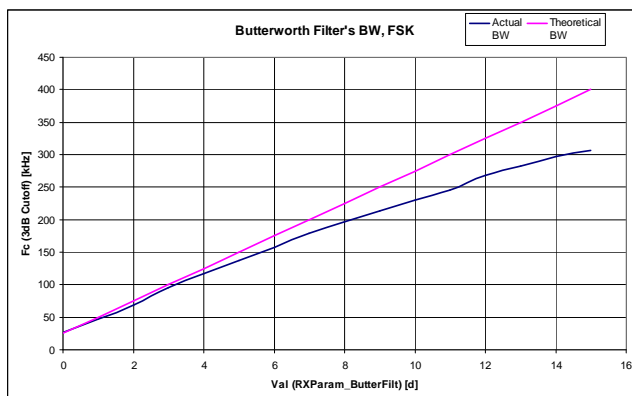

Figure 18: Butterworth Filter's Actual BW

Table 37 suggests filter settings in FSK mode, along with the corresponding passive filter bandwidth and the accepted tolerance on the crystal reference.

### 3.4.6. Channel Filters Setting in OOK Mode

The center frequency,  $f_0$ , is always set to 100kHz. The following chart shows the receiver bandwidth when changing RXParam\_Butterfilt bits, whilst the polyphase filter is activated.

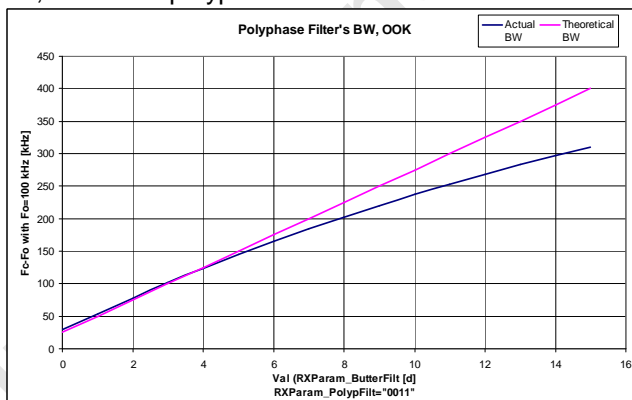

Figure 19: Polyphase Filter's Actual BW

Table 38 suggests a few filter settings in OOK mode, along with the corresponding passive filter bandwidth and the accepted tolerance on the crystal reference.

### 3.4.7. RSSI

After filtering, the In-phase and Quadrature signals are amplified by a chain of 11 amplifiers, each with 6dB gain. The outputs of these amplifiers are used to evaluate the Received Signal Strength (RSSI).

#### 3.4.7.1. Resolution and Accuracy

Whilst the RSSI resolution is 0.5 dB, the absolute accuracy is not expected to be better than +/- 3dB due to process and external component variation. Higher accuracy whilst performing absolute RSSI measurements will require additional calibration.

#### 3.4.7.2. Acquisition Time

In OOK mode, the RSSI evaluates the signal strength by sampling I(t) and Q(t) signals 16 times in each period of the chosen IF2 frequency (refer to section 3.4.1). In FSK mode, the signals are sampled 16 times in each Fdev period, Fdev being the frequency deviation of the companion transmitter. An average is then performed over a sliding window of 16 samples. Hence, the RSSI output register RXParam\_RSSI is updated 16 times in each Fdev or IF2 period.

The following settings should be respected:

- FSK Mode: Ensure that the Fdev parameter (as described in MCPParam\_Fdev) remains consistent with the actual frequency deviation of the companion transmitter.
- OOK reception: Ensure that the Fdev parameter (as described in MCPParam\_Fdev) is equal with the frequency of I(t) and Q(t) signals, i.e. the second Intermediate Frequency, IF2, of the receiver (Note that this equals Fo, the center frequency of the polyphase filter).

### 3.4.7.3. Dynamic Range

The dynamic range of the RSSI is over 70 dB, extending from the nominal sensitivity level. The IF gain setting available in MCPParam\_IF\_gain is used to achieve this dynamic range:

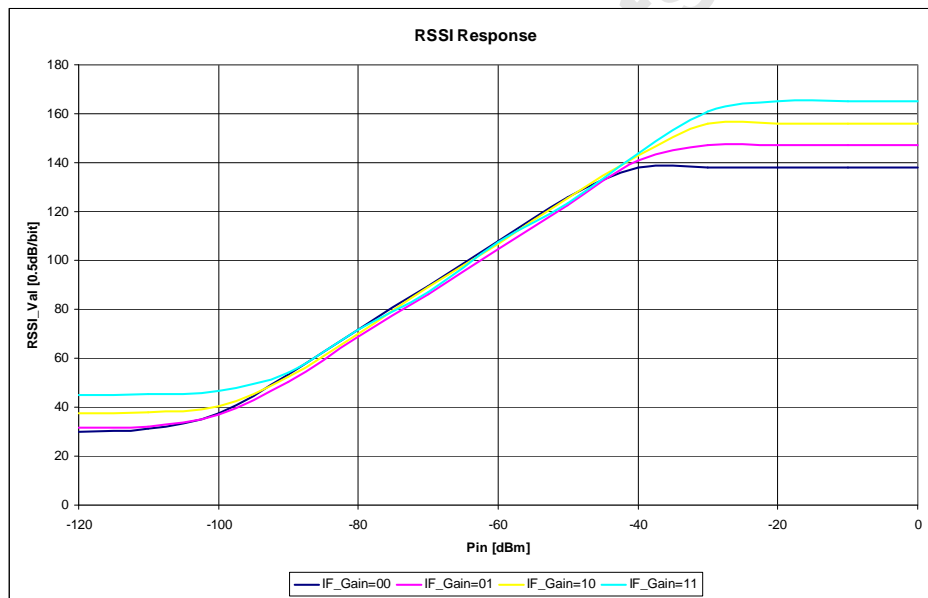

Figure 20: RSSI Dynamic Range

The RSSI response versus input signal is independent of the receiver filter bandwidth. However in the absence of any input signal, the minimum value directly reflects upon the noise floor of the receiver, which is dependant on the filter bandwidth of the receiver.

### 3.4.7.4. RSSI IRQ Source

The SX1211 can also be used to detect a RSSI level above a pre-configured threshold. The threshold is set in IRQParam\_RSSI\_irq\_thresh and the IRQ status stored in IRQParam\_RSSI\_irq (cleared by writing a "1").

An interrupt can be mapped to the IRQ0 or IRQ1 pins via bits IRQParam\_Rx\_stby\_irq0 or IRQParam\_Rx\_stby\_irq1. Figure 21 shows the timing diagram of the RSSI interrupt source, with IRQParam\_RSSI\_irq\_thresh set to 28.

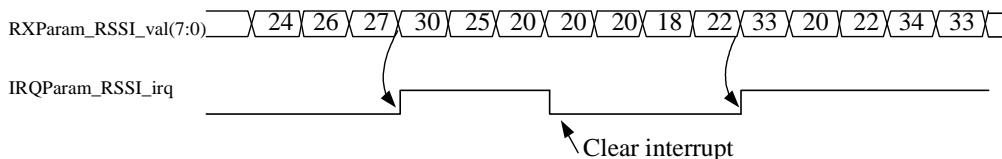

Figure 21: RSSI IRQ Timings

### 3.4.8. Fdev Setting in Receive Mode

The effect of the Fdev setting is different between FSK and OOK modes:

#### 3.4.8.1. FSK Rx Mode

In FSK mode the Fdev setting, as configured by MCPParam\_Freq\_Dev, sets sampling frequencies on the receiver. The user should make it consistent with the frequency deviation of the FSK signal that is received.

#### 3.4.8.2. OOK Rx Mode

The frequency deviation Fdev, as described above, sets the sampling rate of the RSSI block. It is therefore necessary to set Fdev to the recommended low-IF frequency, IF2, of 100 kHz:

$$Fdev = IF2 = 100kHz$$

$$MCPParam\_Freq\_dev = "00000011"$$

### 3.4.9. FSK Demodulator

The FSK demodulator provides data polarity information, based on the relative phase of the input I and Q signals at the baseband. Its outputs can be fed to the Bit Synchronizer to recover the timing information. The user can also use the raw, unsynchronized, output of the FSK demodulator in Continuous mode.

The FSK demodulator of the SX1211 operates most effectively for FSK signals with a modulation index greater than or equal to two:

$$\beta = \frac{2 * Fdev}{BR} \geq 2$$

### 3.4.10. OOK Demodulator

The OOK demodulator performs a comparison of the RSSI output and a threshold value. Three different threshold modes are available, programmed through the RXParam\_OOK\_thresh\_type register.

The recommended mode of operation is the “Peak” threshold mode, illustrated below in Figure 22:

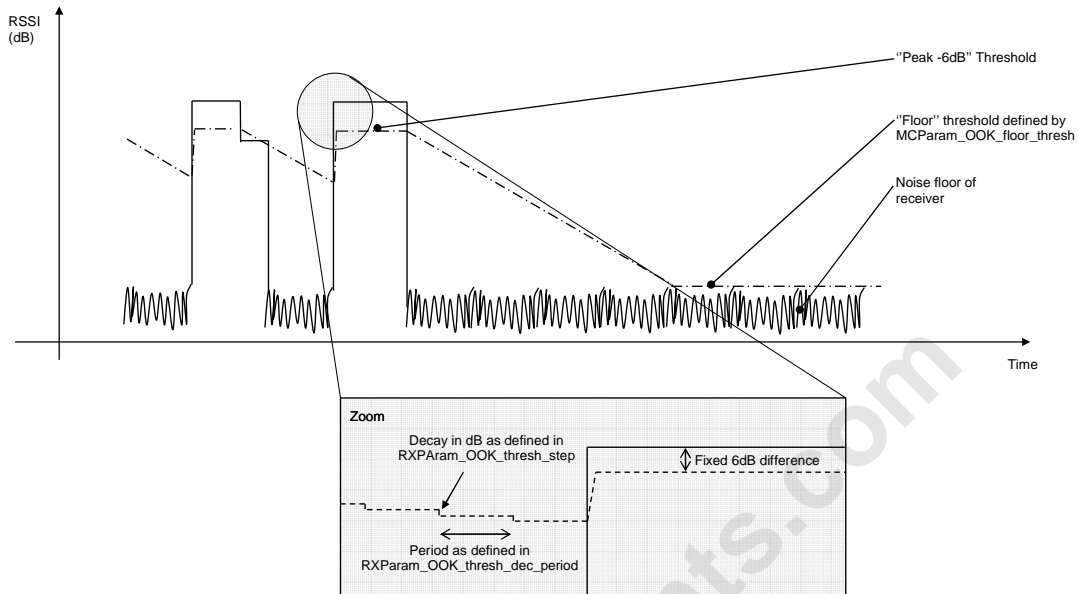

Figure 22: OOK Demodulator Description

In peak threshold mode the comparison threshold level is the peak value of the RSSI, reduced by 6dB. In the absence of an input signal or during the reception of a logical "0", the acquired peak value is decremented by one RXParam\_OOK\_thresh\_step every RXParam\_OOK\_thresh\_dec\_period.

When the RSSI output is null for a long time (for instance after a long string of "0" received, or if no transmitter is present), the peak threshold level will continue falling until it reaches the "Floor Threshold" that is programmed through the register MCPParam\_OOK\_floor\_thresh.

The default settings of the OOK demodulator lead to the performance stated in the electrical specification. However, in applications in which sudden signal drops are awaited during a reception, the three parameters shall be optimized accordingly.

### 3.4.10.1. Optimizing the Floor Threshold

MCPParam\_OOK\_floor\_thres determines the sensitivity of the OOK receiver, as it sets the comparison threshold for weak input signals (i.e. those close to the noise floor). Significant sensitivity improvements can be generated if configured correctly.

Note that the noise floor of the receiver at the demodulator input depends on:

- The noise figure of the receiver.
- The gain of the receive chain from antenna to base band.
- The matching - including SAW filter.
- The bandwidth of the channel filters.

It is therefore important to note that the setting of MCPParam\_OOK\_floor\_thresh will be application dependant. The following procedure is recommended to optimize MCPParam\_OOK\_floor\_thresh.



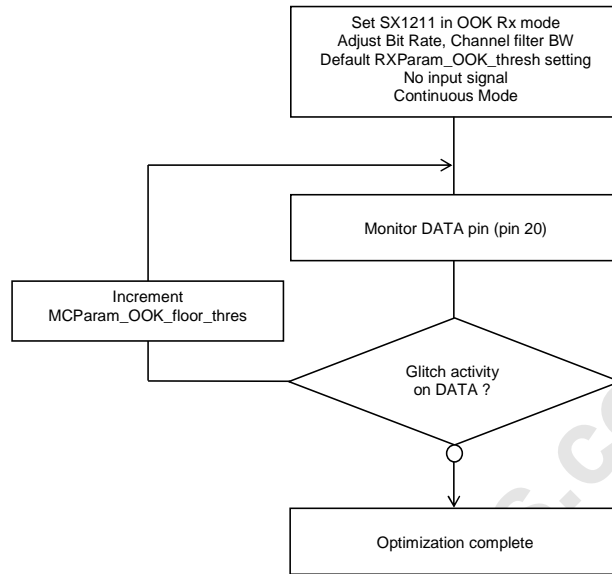

Figure 23: Floor Threshold Optimization

The new floor threshold value found during this test should be the value used for OOK reception with those receiver settings.

Note that if the output signal on DATA is logic “1”, the value of MCPParam\_OOK\_floor\_thres is below the noise floor of the receiver chain. Conversely, if the output signal on DATA is logic “1”, the value of MAParam\_floor\_thres is several dB above the noise floor.

### 3.4.10.2. Optimizing OOK Demodulator Response for Fast Fading Signals

A sudden drop in signal strength can cause the bit error rate to increase. For applications where the expected signal drop can be estimated the following OOK demodulator parameters RXParam\_OOK\_thresh\_step and RXParam\_OOK\_thresh\_dec\_period can be optimized as described below for a given number of threshold decrements per bit RXParam\_OOK\_thresh\_dec\_period:

- 000 → once in each chip period (d)
- 001 → once in 2 chip periods
- 010 → once in 4 chip periods
- 011 → once in 8 chip periods
- 100 → twice in each chip period
- 101 → 4 times in each chip period
- 110 → 8 times in each chip period
- 111 → 16 times in each chip period

For each decrement of RXParam\_OOK\_thresh\_step:

- 000 → 0.5 dB (d)
- 001 → 1.0 dB
- 010 → 1.5 dB
- 011 → 2.0 dB
- 100 → 3.0 dB
- 101 → 4.0 dB
- 110 → 5.0 dB
- 111 → 6.0 dB

### 3.4.10.3. Alternative OOK Demodulator Threshold Modes

In addition to the Peak OOK threshold mode, the user can alternatively select two other types of threshold detectors:

- Fixed threshold: The value is selected through the `MCPParam_OOK_floor_thresh` register (refer to section 3.4.10.1 for further information concerning optimization of the floor threshold).
- Average threshold: Data supplied by the RSSI block is averaged with the following cutoff frequency:

$$RXParam\_OOK\_cutoff = 00 \Rightarrow F_{cutoff} = \frac{BR}{8 * \pi}$$

$$RXParam\_OOK\_cutoff = 11 \Rightarrow F_{cutoff} = \frac{BR}{32 * \pi}$$

In the first example, the higher cut-off frequency enables a sequence of up to 8 consecutive “0” or “1” to be supported, whilst the lower cut-off frequency presented in the second example allows for the correct reception of up to 32 consecutive “0” or “1”.

### 3.4.11. Bit Synchronizer

The Bit Synchronizer (BitSync) is a block that provides a clean and synchronized digital output, free of glitches.

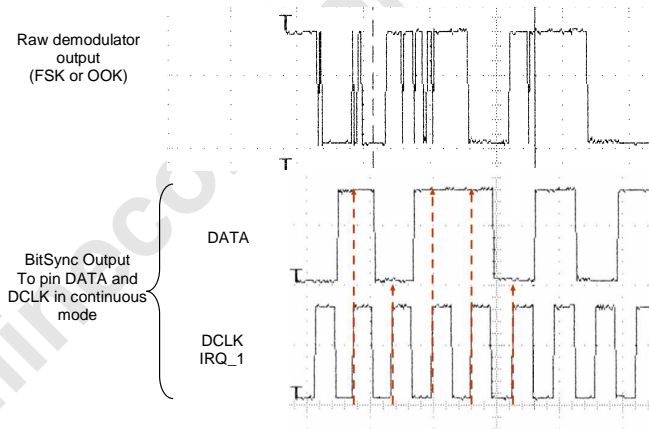

Figure 24: BitSync Description

The BitSync can be disabled through the bits `RXParam_Bitsync_off`, and by holding pin `IRQ1` low. However, for optimum receiver performance, its use when running Continuous mode is strongly advised. With this option a DCLK signal is present on pin `IRQ_1`.

The BitSync is automatically activated in Buffered and Packet modes. The bit synchronizer bit-rate is controlled by `MCPParam_BR`. For a given bit rate, this parameter is determined by:

$$BR = \frac{F_{XTAL}}{64 * [1 + MCPParam\_BR]}$$

For proper operation, the Bit Synchronizer must first receive three bytes of alternating logic value preamble, i.e. "0101" sequences. After this startup phase, the rising edge of DCLK signal is centered on the demodulated bit. Subsequent data transitions will preserve this centering.

This has two implications:

- Firstly, if the Bit Rates of Transmitter and Receiver are known to be the same, the SX1211 will be able to receive an infinite unbalanced sequence (all "0s" or all "1s") with no restriction.
- If there is a difference in Bit Rate between Tx and Rx, the amount of adjacent bits at the same level that the BitSync can withstand can be estimated as:

$$\text{NumberOfBits} = \frac{1}{2} * \frac{BR}{\Delta BR}$$

This implies approximately 6 consecutive unbalanced bytes when the Bit Rate precision is 1%, which is easily achievable (crystal tolerance is in the range of 50 to 100 ppm).

### 3.4.12. Alternative Settings

Bit Synchronizer and Active channel filter settings are a function of the reference oscillator crystal frequency,  $F_{XTAL}$ . Settings other than those programmable with a 12.8 MHz crystal can be obtained by selection of the correct reference oscillator frequency. Please contact your local Semtech representative for further details.

### 3.4.13. Data Output

After OOK or FSK demodulation, the baseband signal is made available to the user on pin 20, DATA, when Continuous mode is selected.

In Buffered and Packet modes, the data is retrieved from the FIFO through the SPI interface.

## 4. Operating Modes

This section summarizes the settings for each operating mode of the SX1211, and explains the functionality available and the timing requirements for switching between modes.

### 4.1. Modes of Operation

Table 12: Operating Modes

Mode	MCPParam_Chip_mode	Active blocks
Sleep	000	SPI, POR
Standby	001	SPI, POR, Top regulator, digital regulator, XO, CLKOUT (if activated through OSCParam_Clkout)
FS	010	Same + VCO regulator, all PLL and LO generation blocks
Receive	011	Same as FS mode + LNA, first mixer, IF amplifier, second mixer set, channel filters, baseband amplifiers and limiters, RSSI, OOK or FSK demodulator, BitSync and all digital features if enabled
Transmit	100	Same as FS mode + DDS, Interpolation filters, all up-conversion mixers, PA driver, PA and external VR_PA pin output for PA choke.

### 4.2. Digital Pin Configuration vs. Chip Mode

Table 13 describes the state of the digital IOs in each of the above described modes of operation, regardless of the data operating mode (Continuous, Buffered, or Packet).

Table 13: Pin Configuration vs. Chip Mode

Chip Mode ..... Pin	Sleep mode	Standby mode	FS mode	Receive mode	Transmit mode	Comment
NSS_CONFIG	Input	Input	Input	Input	Input	NSS_CONFIG has the priority over NSS_DATA
NSS_DATA	Input	Input	Input	Input	Input	
MISO	Input	Input	Input	Input	Input	Output only if NSS_CONFIG or NSSDATA='0'
MOSI	Input	Input	Input	Input	Input	
SCK	Input	Input	Input	Input	Input	
IRQ_0	High-Z	Output (1)	Output (1)	Output	Output	
IRQ_1	High-Z	Output (1)	Output (1)	Output	Output	
DATA	Input	Input	Input	Output	Input	
CLKOUT	High-Z	Output	Output	Output	Output	
PLL_LOCK	High-Z	Output (2)	Output (2)	Output (2)	Output (2)	

Notes:

- (1): High-Z if Continuous mode is activated, else Output
- (2): Output if PLL\_lock\_en = 1, else High-Z
- (3): Valid logic states must be applied to inputs at all times to avoid unwanted leakage currents

## 5. Data Processing

### 5.1. Overview

#### 5.1.1. Block Diagram

Figure 25, illustrates the SX1211 data processing circuit. Its role is to interface the data to/from the modulator/demodulator and the uC access points (SPI, IRQ and DATA pins). It also controls all the configuration registers.

The circuit contains several control blocks which are described in the following paragraphs.

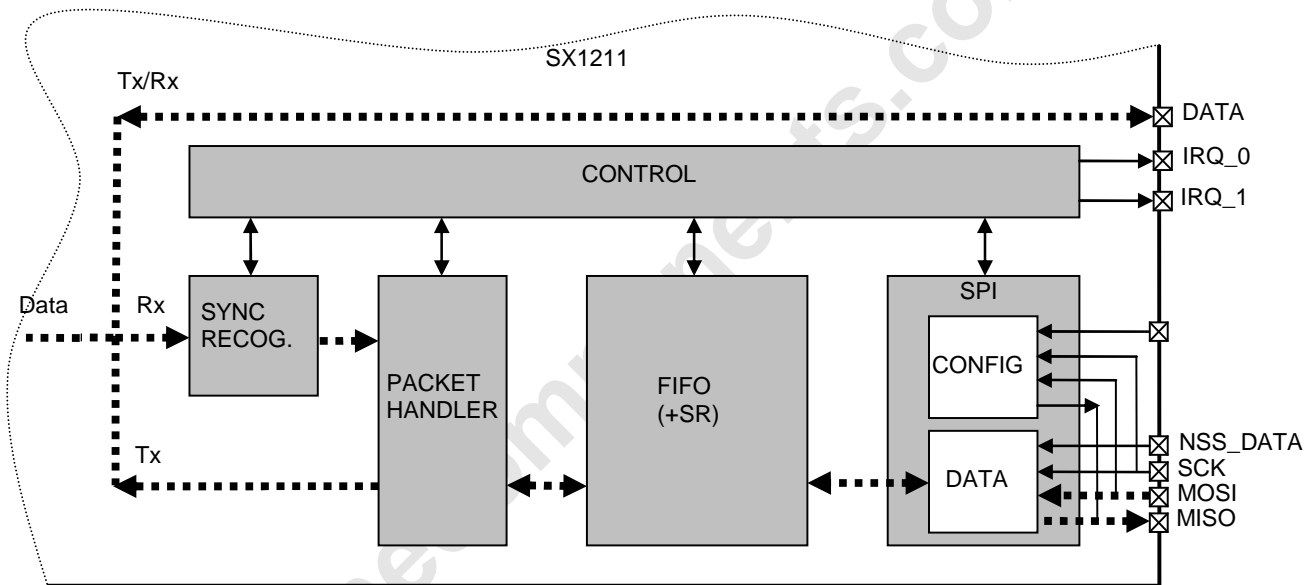

Figure 25: SX1211's Data Processing Conceptual View

The SX1211 implements several data operation modes, each with their own data path through the data processing section. Depending on the data operation mode selected, some control blocks are active whilst others remain disabled.

#### 5.1.2. Data Operation Modes

The SX1211 has three different data operation modes selectable by the user:

- **Continuous mode:** each bit transmitted or received is accessed in real time at the DATA pin. This mode may be used if adequate external signal processing is available.
- **Buffered mode:** each byte transmitted or received is stored in a FIFO and accessed via the SPI bus. uC processing overhead is hence significantly reduced compared to Continuous mode operation. The packet length is unlimited.
- **Packet mode (recommended):** user only provides/retrieves payload bytes to/from the FIFO. The packet is automatically built with preamble, Sync word, and optional CRC, DC free encoding and the reverse operation is performed in reception. The uC processing overhead is hence reduced further compared to Buffered mode. The maximum payload length is limited to the maximum FIFO limit of 64 bytes

Table 14: Data Operation Mode Selection

MCPParam_Data_mode	Data Operation Mode
00	Continuous
01	Buffered
1x	Packet

Each of these data operation modes is described fully in the following sections.

## 5.2. Control Block Description

### 5.2.1. SPI Interface

#### 5.2.1.1. Overview

As illustrated in the Figure 26 below, the SX1211's SPI interface consists of two sub blocks:

- **SPI Config:** used in all data operation modes to read and write the configuration registers which control all the parameters of the chip (operating mode, bit rate, etc...)
- **SPI Data:** used in Buffered and Packet mode to write and read data bytes to and from the FIFO. (FIFO interrupts can be used to manage the FIFO content.)

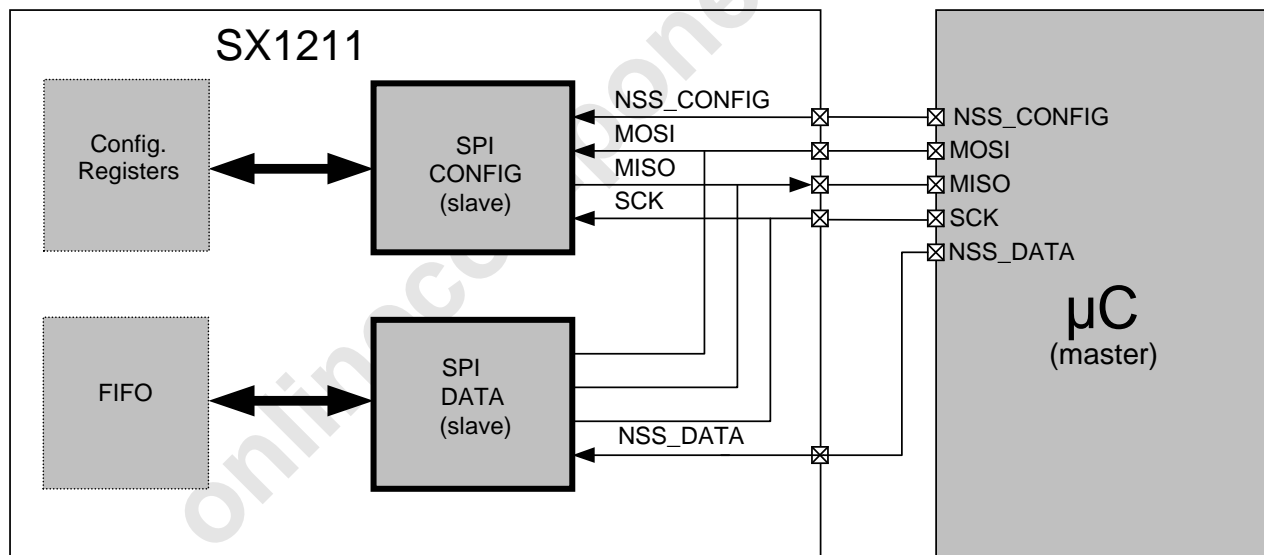

Figure 26: SPI Interface Overview and uC Connections

Both interfaces are configured in slave mode whilst the uC is configured as the master. They have separate selection pins (NSS\_CONFIG and NSS\_DATA) but share the remaining pins:

- **SCK (SPI Clock):** clock signal provided by the uC
- **MOSI (Master Out Slave In):** data input signal provided by the uC
- **MISO (Master In Slave Out):** data output signal provided by the SX1211

As described below, only one interface can be selected at a time with NSS\_CONFIG having the priority:

Table 15: Config vs. Data SPI Interface Selection

NSS_DATA	NSS_CONFIG	SPI Interface
0	0	Config
0	1	Data
1	0	Config
1	1	None

The following paragraphs describe how to use each of these interfaces.

### 5.2.1.2. SPI Config

- Write Register

To write a value into a configuration register the timing diagram below should be carefully followed by the uC. The register's new value is effective from the rising edge of NSS\_CONFIG.

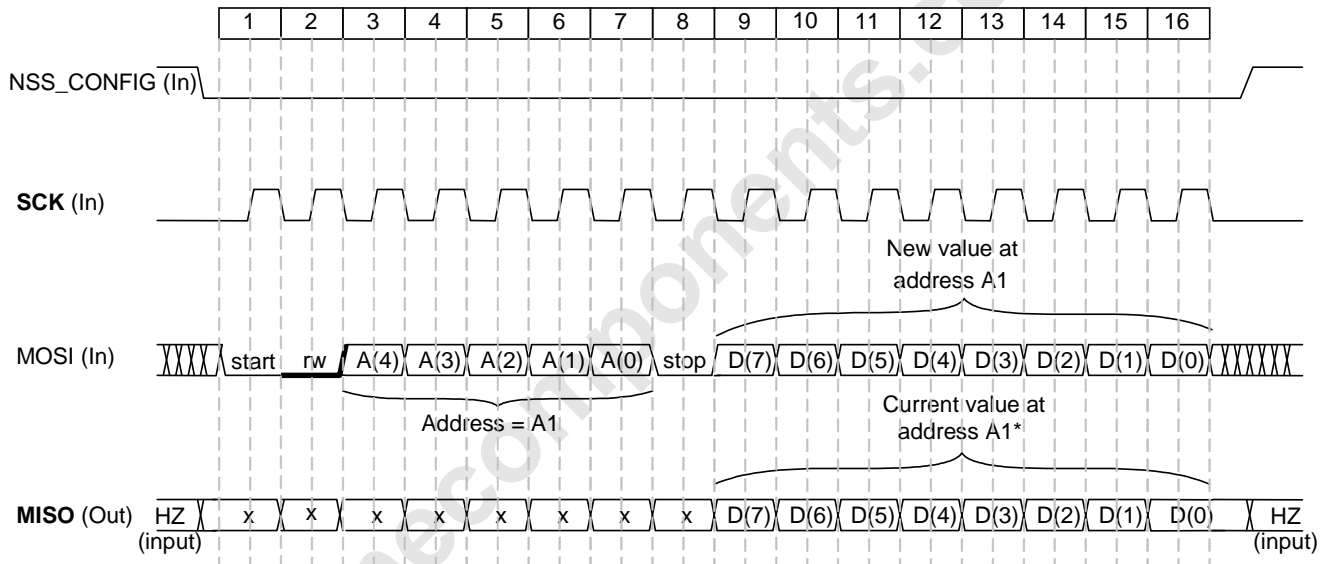

\* when writing the new value at address A1, the current content of A1 can be read by the uC.  
(In)/(Out) refers to SX1211 side

Figure 27: Write Register Sequence

Note that when writing more than one register successively, it is not compulsory to toggle NSS\_CONFIG back high between two write sequences. The bytes are alternatively considered as address and value. In this instance, all new values will become effective on rising edge of NSS\_CONFIG.

- Read Register

To read the value of a configuration register the timing diagram below should be carefully followed by the uC.



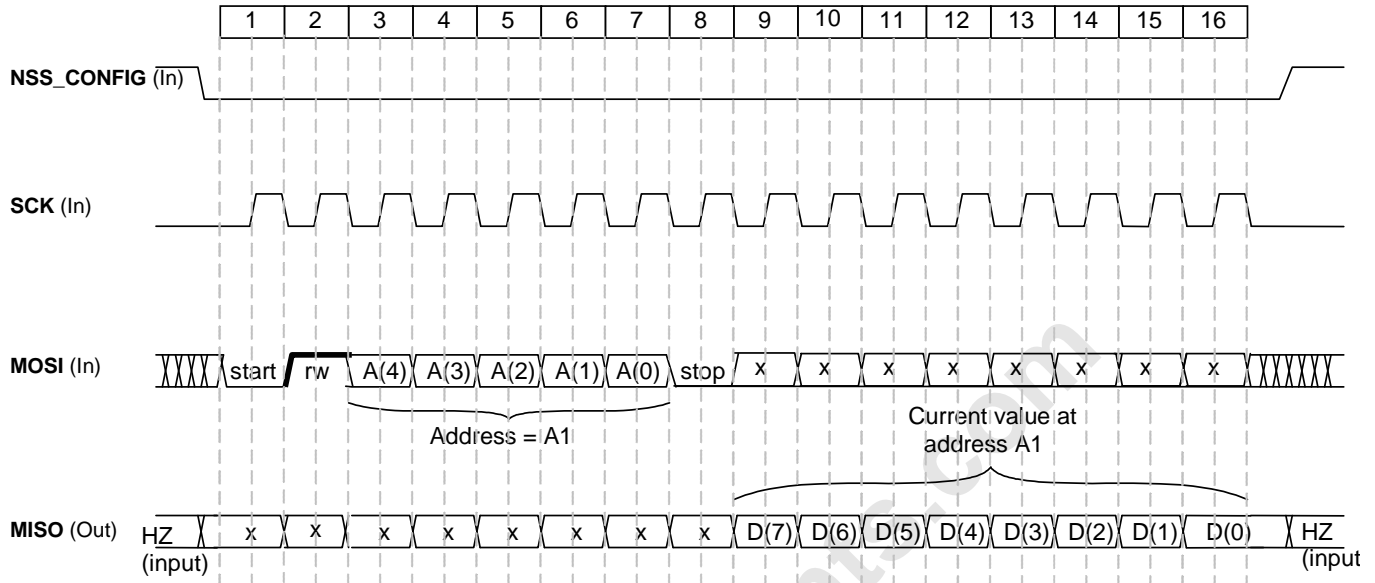

Figure 28: Read Register Sequence

Note that when reading more than one register successively, it is not compulsory to toggle NSS\_CONFIG back high between two read sequences. The bytes are alternatively considered as address and value.

### 5.2.1.3. SPI Data

- Write Byte (before/during Tx)

To write bytes into the FIFO the timing diagram below should be carefully followed by the uC.

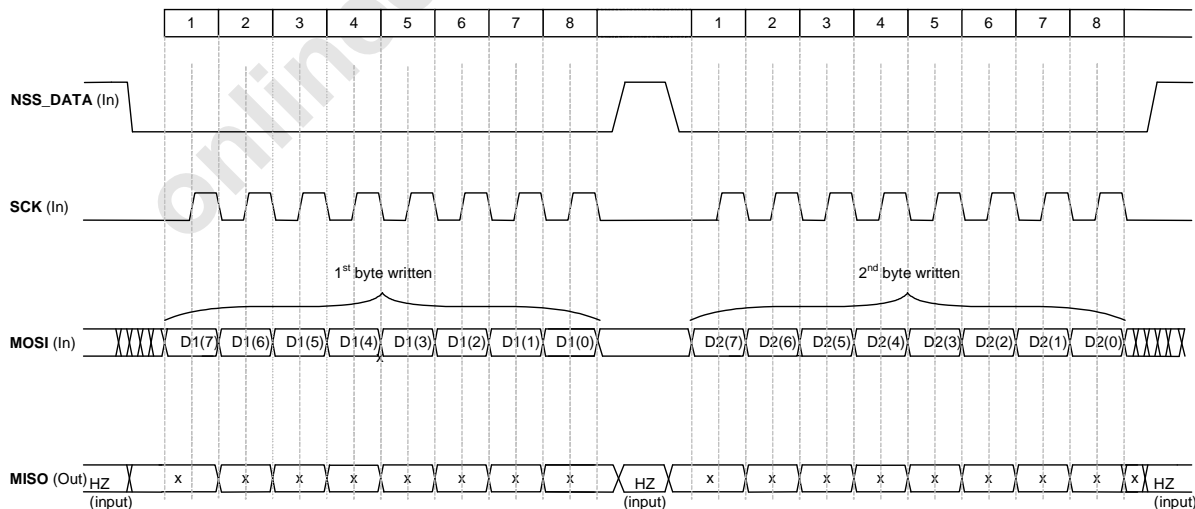

Figure 29: Write Bytes Sequence (ex: 2 bytes)

Note that it is compulsory to toggle NSS\_DATA back high between each byte written. The byte is pushed into the FIFO on the rising edge of NSS\_DATA

▪ Read Byte (after/during Rx)

To read bytes from the FIFO the timing diagram below should be carefully followed by the uC.

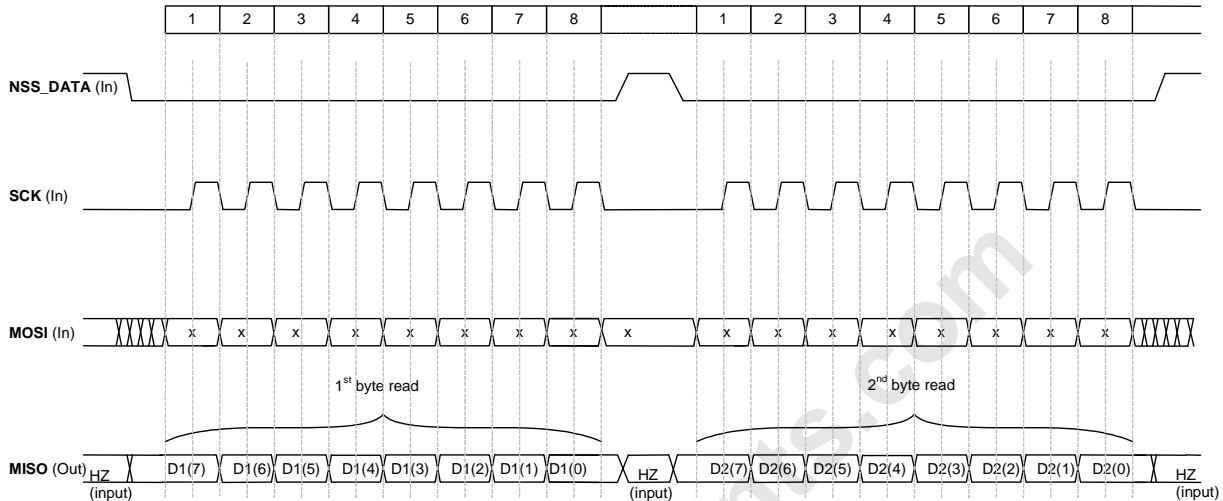

Figure 30: Read Bytes Sequence (ex: 2 bytes)

Note that it is compulsory to toggle NSS\_DATA back high between each byte read.

**5.2.2. FIFO**

**5.2.2.1. Overview and Shift Register (SR)**

In Buffered and Packet modes of operation, both data to be transmitted and that has been received are stored in a configurable FIFO (First In First Out) device. It is accessed via the SPI Data interface and provides several interrupts for transfer management.

The FIFO is 1 byte (8 bits) wide hence it only performs byte (parallel) operations, whereas the demodulator functions serially. A shift register is therefore employed to interface the two devices. In transmit mode it takes bytes from the FIFO and outputs them serially (MSB first) at the programmed bit rate to the modulator. Similarly, in Rx the shift register gets bit by bit data from the demodulator and writes them byte by byte to the FIFO. This is illustrated in figure below.

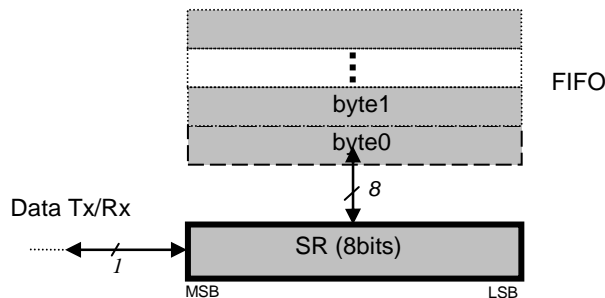

Figure 31: FIFO and Shift Register (SR)

**5.2.2.2. Size Selection**

The FIFO width is programmable, to 16, 32, 48 or 64 bytes via MCPParam\_Fifo\_size

**5.2.2.3. Interrupt Sources and Flags**

All interrupt sources and flags are configured in the IRQParam section of the configuration register, with the exception of Fifo\_threshold :

- /Fifoempty: /Fifoempty interrupt source is low when byte 0, i.e. whole FIFO, is empty. Otherwise it is high. Note that when retrieving data from the FIFO, /Fifoempty is updated on NSS\_DATA falling edge, i.e. when /Fifoempty is updated to low state the currently started read operation must be completed. In other words, /Fifoempty state must be checked **after** each read operation for a decision on the next one (/Fifoempty = 1: more byte(s) to read; /Fifoempty = 0: no more byte to read).
- Write\_byte: Write\_byte interrupt source goes high for 1 bit period each time a new byte is transferred from the SR to the FIFO (i.e. each time a new byte is received)
- Fifofull: Fifofull interrupt source is high when the last FIFO byte, i.e. the whole FIFO, is full. Otherwise it is low.
- Fifo\_overrun\_clr: Fifo\_overrun\_clr flag is set when a new byte is written by the user (in Tx or Standby modes) or the SR (in Rx mode) while the FIFO is already full. Data is lost and the flag should be cleared by writing a 1, note that the FIFO will also be cleared.
- Tx\_done: Tx\_done interrupt source goes high when FIFO is empty and the SR's last bit has been send to the modulator (i.e. the last bit of the packet has been sent). One bit period delay is required after the rising edge of Tx\_done to ensure correct RF transmission of the last bit. In practice this may not require special care in the uC software due to IRQ processing time.
- Fifo\_threshold: Fifo\_threshold interrupt source's behavior depends on the running mode (Tx, Rx or Stby mode) and the threshold itself can be programmed via MCPParam\_Fifo\_thresh (B value). This behavior is illustrated in Figure 32.

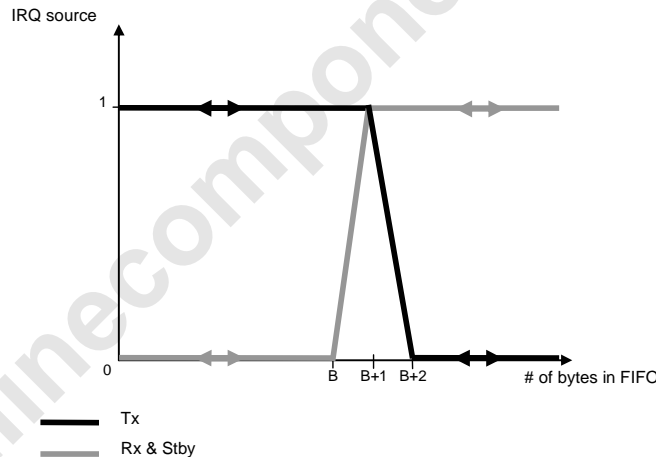

Figure 32: FIFO Threshold IRQ Source Behavior

**5.2.2.4. FIFO Clearing**

Table 16 below summarizes the status of the FIFO when switching between different modes

Table 16: Status of FIFO when Switching Between Different Modes of the Chip

From	To	FIFO Status	Comments
Stby	Tx	Cleared	In Buffered mode, FIFO cannot be written in Stby before Tx
		Not cleared	In Packet mode, FIFO can be written in Stby before Tx
Stby	Rx	Cleared	
Rx	Tx	Cleared	
Rx	Stby	Not cleared	In Packet & Buffered modes FIFO can be read in Stby after Rx
Tx	Rx	Cleared	
Tx	Stby	Not cleared	
Any	Sleep	Cleared	

### 5.2.3. Sync Word Recognition

#### 5.2.3.1. Overview

Sync word recognition (also called Pattern recognition in previous products) is activated by setting `RXParam_Sync_on`. The bit synchronizer must also be activated.

The block behaves like a shift register; it continuously compares the incoming data with its internally programmed Sync word and asserts the Sync IRQ source on each occasion that a match is detected. This is illustrated in Figure 33.

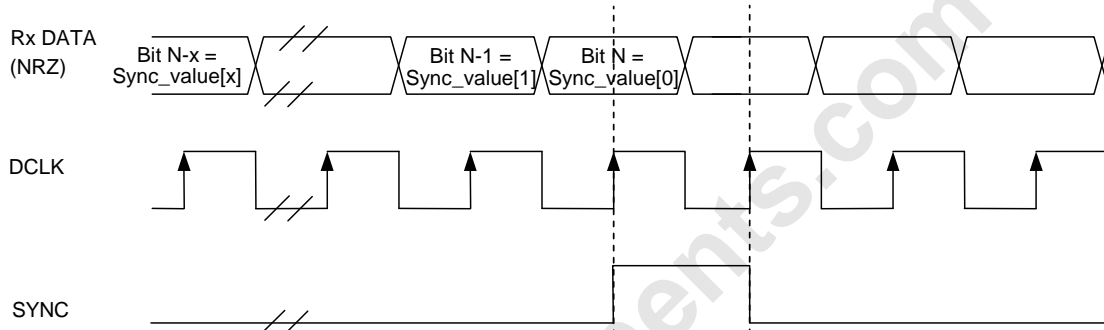

Figure 33: Sync Word Recognition

During the comparison of the demodulated data, the first bit received is compared with bit 7 (MSB) of byte at address 22 and the last bit received is compared with bit 0 (LSB) of the last byte whose address is determined by the length of the Sync word.

When the programmed Sync word is detected the user can assume that this incoming packet is for the node and can be processed accordingly.

#### 5.2.3.2. Configuration

- **Size:** Sync word size can be set to 8, 16, 24 or 32 bits via `RXParam_Sync_size`. In Packet mode this field is also used for Sync word generation in Tx mode.
- **Error tolerance:** The number of errors tolerated in the Sync word recognition can be set to 0, 1, 2 or 3 via `RXParam_Sync_tol`.
- **Value:** The Sync word value is configured in `SYNCPParam_Sync_value`. In Packet mode this field is also used for Sync word generation in Tx mode.

### 5.2.4. Packet Handler

The packet handler is the block used in Packet mode. Its functionality is fully described in section 5.5.

### 5.2.5. Control

The control block configures and controls the full chip's behavior according to the settings programmed in the configuration registers.

### 5.3. Continuous Mode

#### 5.3.1. General Description

As illustrated in Figure 34, in Continuous mode the NRZ data to (from) the (de)modulator is directly accessed by the uC on the bidirectional DATA pin (20). The SPI Data, FIFO and packet handler are thus inactive.

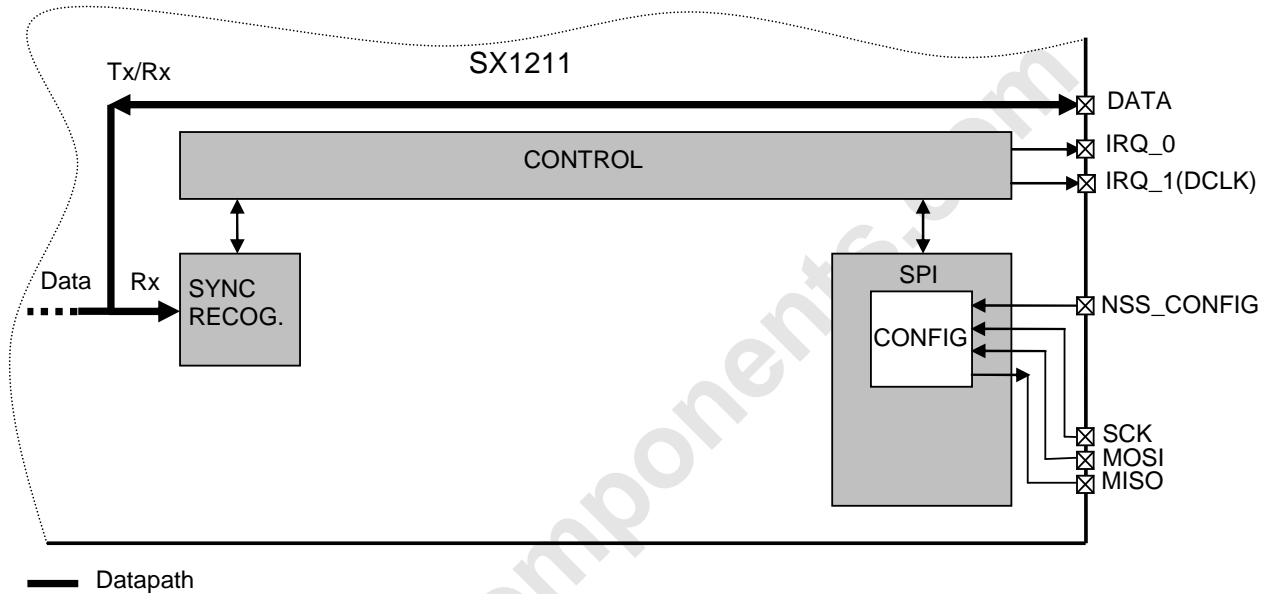

Figure 34: Continuous Mode Conceptual View

#### 5.3.2. Tx Processing

In Tx mode, a synchronous data clock for an external uC is provided on IRQ\_1 pin. Its timing with respect to the data is illustrated in Figure 35. DATA is internally sampled on the rising edge of DCLK so the uC can change logic state anytime outside the greyed out setup/hold zone.

The use of DCLK is compulsory in FSK and optional in OOK.

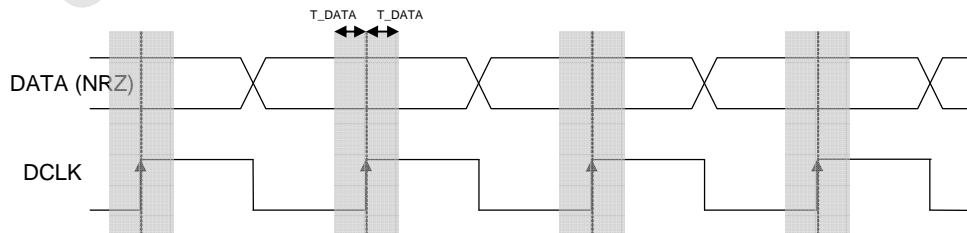

Figure 35: Tx Processing in Continuous Mode

### 5.3.3. Rx Processing

If the bit synchronizer is disabled, the raw demodulator output is made directly available on DATA pin and no DCLK signal is provided.

Conversely, if the bit synchronizer is enabled, synchronous cleaned data and clock are made available respectively on DATA and IRQ\_1 pins. DATA is sampled on the rising edge of DCLK and updated on the falling edge as illustrated in Figure 36.

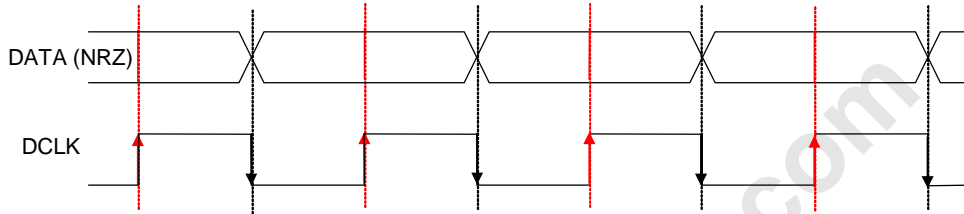

Figure 36: Rx Processing in Continuous Mode

Note that in Continuous mode it is always recommended to enable the bit synchronizer to clean the DATA signal even if the DCLK signal is not used by the uC. (bit synchronizer is automatically enabled in Buffered and Packet mode).

### 5.3.4. Interrupt Signals Mapping

The tables below give the description of the interrupts available in Continuous mode.

	Rx_stby_irq_0	Rx
IRQ_0	00 (d)	Sync
	01	RSSI
	1x	-
IRQ_1		DCLK

Table 17: Interrupt Mapping in Continuous Rx Mode

Note: In Continuous mode, no interrupt is available in Stby mode

	Tx
IRQ_0	-
IRQ_1	DCLK

Table 18: Interrupt Mapping in Continuous Tx Mode

### 5.3.5. uC Connections

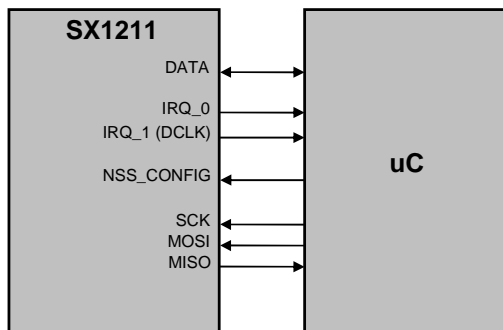

Figure 37: uC Connections in Continuous Mode

Note that some connections may not be needed depending on the application:

- IRQ\_0: if Sync and RSSI interrupts are not used. In this case, leave floating.
- IRQ\_1: if the chip is never used in Tx FSK mode (DCLK connection is not compulsory in Rx and Tx OOK modes). In this case, leave floating.
- MISO: if no read register access is needed. In this case, pull-up to VDD through a 100 kΩ resistor.

In addition, NSS\_DATA pin (unused in continuous mode) should be pulled-up to VDD through a 100 kΩ resistor. Please refer to Table 13 for SX1211's pins configuration

### 5.3.6. Continuous Mode Example

- Configure all data processing related registers listed below appropriately. In this example we assume that both Bit synchronizer and Sync word recognition are on.

Table 19: Relevant Configuration Registers in Continuous Mode (data processing related only)

		Tx	Rx	Description
<b>MCPParam</b>	Data_mode_x	X	X	Defines data operation mode (→ Continuous)
<b>IRQParam</b>	Rx_stby_irq_0		X	Defines IRQ_0 source in Rx mode
<b>RXParam</b>	Sync_on		X	Enables Sync word recognition
	Sync_size		X	Defines Sync word size
	Sync_tol		X	Defines the error tolerance on Sync word recognition
<b>SYNCPParam</b>	Sync_value		X	Defines Sync word value

#### Tx Mode:

- Go to Tx mode (and wait for Tx to be ready, see Figure 50)
- Send all packet's bits on DATA pin synchronously with DCLK signal provided on IRQ\_1
- Go to Sleep mode

#### Rx Mode:

- Program Rx interrupts: IRQ\_0 mapped to Sync (Rx\_stby\_irq\_0="00") and IRQ\_1 mapped to DCLK (Bit synchronizer enabled)
- Go to Rx mode (note that Rx is not ready immediately, see Figure 49)
- Wait for Sync interrupt
- Get all packet bits on DATA pin synchronously with DCLK signal provided on IRQ\_1
- Go to Sleep mode

## 5.4. Buffered Mode

### 5.4.1. General Description

As illustrated in Figure 38, for Buffered mode operation the NRZ data to (from) the (de)modulator is not directly accessed by the uC but stored in the FIFO and accessed via the SPI Data interface. This frees the uC for other tasks between processing data from the SX1211, furthermore it simplifies software development and reduces uC performance requirements (speed, reactivity). Note that in this mode the packet handler stays inactive.

An important feature is also the ability to empty the FIFO in Stby mode, ensuring low power consumption and adding greater software flexibility.

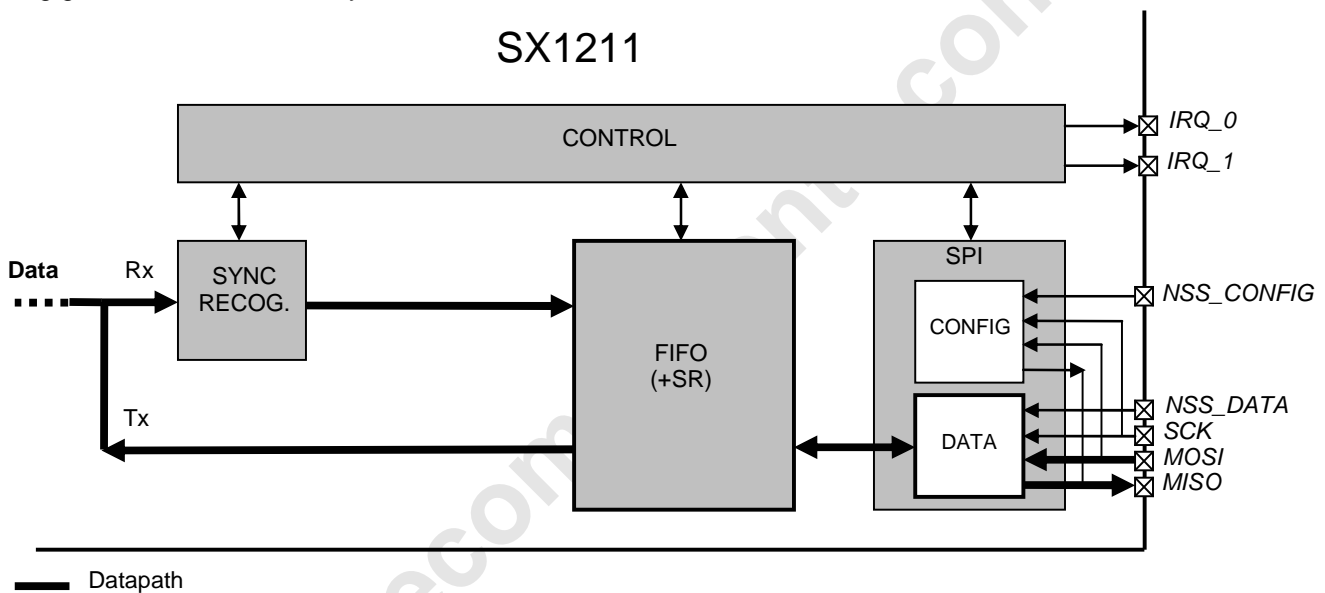

Figure 38: Buffered Mode Conceptual View

Note that Bit Synchronizer is automatically enabled in Buffered mode. The Sync word recognition must be enabled (RXParam\_Sync\_on=1) independently of the FIFO filling method selected (IRQParam\_Fifo\_fill\_method).

### 5.4.2. Tx Processing

After entering Tx in Buffered mode, the chip expects the uC to write into the FIFO, via the SPI Data interface, all the data bytes to be transmitted (preamble, Sync word, payload...).

Actual transmission of first byte will start either when the FIFO is not empty (i.e. first byte written by the uC) or when the FIFO is full depending on bit IRQParam\_Tx\_start\_irq\_0.

In Buffered mode the packet length is not limited, i.e. as long as there are bytes inside the FIFO they are sent. When the last byte is transferred to the SR, /Fifoempty IRQ source is asserted to warn the uC, at that time FIFO can still be filled with additional bytes if needed.

When the last bit of the last byte has left the SR (i.e. 8 bit periods later), the Tx\_done interrupt source is asserted and the user can exit Tx mode after waiting at least 1 bit period from the last bit processed by modulator.



If the transmitter is switched off (for example due to entering another chip mode) during transmission it will stop immediately, even if there is still unsent data.

Figure 39 illustrates Tx processing with a 16 byte FIFO depth and Tx\_start\_irq\_0=0. Please note that in this example the packet length is equal to FIFO size, but this does not need to be the case, the uC can use the FIFO interrupts anytime during Tx to manage FIFO contents and write additional bytes.

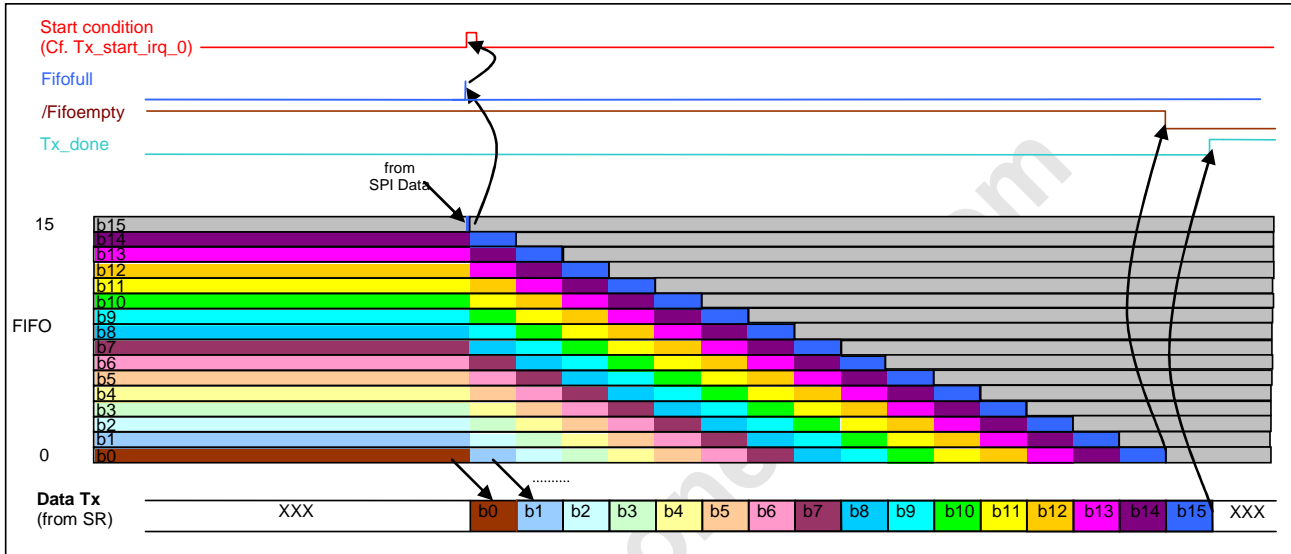

Figure 39: Tx processing in Buffered Mode (FIFO size = 16, Tx\_start\_irq\_0=0)

### 5.4.3. Rx Processing

After entering Rx in Buffered mode, the chip requires the uC to retrieve the received data from the FIFO. The FIFO will actually start being filled with received bytes either; when a Sync word has been detected (in this case only the bytes following the Sync word are filled into the FIFO) or when the Fifo\_fill bit is asserted by the user - depending on the state of bit, IRQParam\_Fifo\_fill\_method.

In Buffered mode, the packet length is not limited i.e. as long as Fifo\_fill is set, the received bytes are shifted into the FIFO.

The uC software must therefore manage the transfer of the FIFO contents by interrupt and ensure reception of the correct number of bytes. (In this mode, even if the remote transmitter has stopped, the demodulator will output random bits from noise)

When the FIFO is full, Fifofull IRQ source is asserted to alert the uC, that at that time, the FIFO can still be unfilled without data loss. If the FIFO is not unfilled, once the SR is also full (i.e. 8 bits periods later) Fifo\_overrun\_clr is asserted and SR's content is lost.

Figure 40 illustrates an Rx processing with a 16 bytes FIFO size and Fifo\_fill\_method=0. Please note that in the illustrative example of section 5.4.6, the uC does not retrieve any byte from the FIFO through SPI Data, causing overrun.

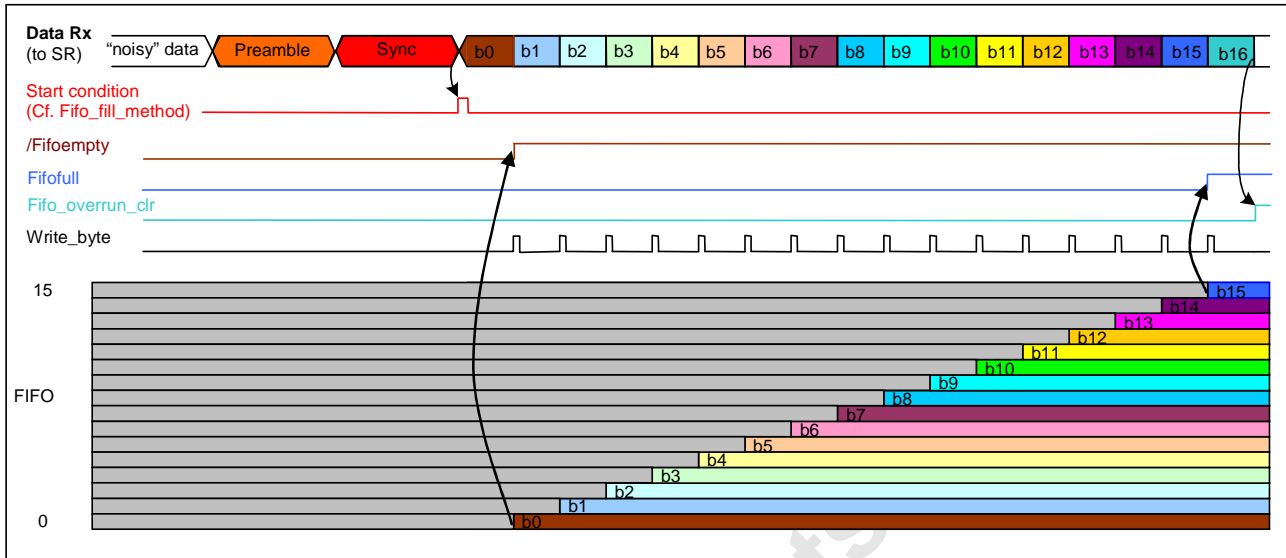

Figure 40: Rx Processing in Buffered Mode (FIFO size=16, Fifo\_fill\_method=0)

#### 5.4.4. Interrupt Signals Mapping

The tables below describe the interrupts available in Buffered mode.

	Rx_stby_irq_x	Rx	Stby
IRQ_0	00 (d)	-	-
	01	Write_byte	-
	10	/Fifoempty	/Fifoempty
	11	Sync	-
IRQ_1	00 (d)	-	-
	01	Fifofull	Fifofull
	10	RSSI	-
	11	Fifo_threshold	Fifo_threshold

Table 20: Interrupt Mapping in Buffered Rx and Stby Modes

		Tx
IRQ_1	IRQ_0	/Fifoempty
	Tx_irq_1=0 (d)	Fifofull
	Tx_irq_1=1	Tx_done

Table 21: Interrupt Mapping in Buffered Tx Mode

### 5.4.5. uC Connections

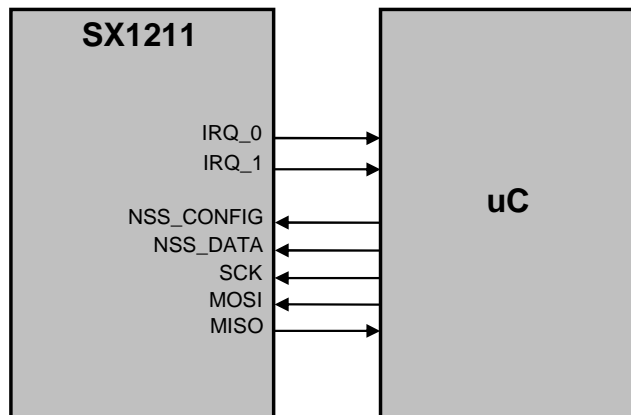

Figure 41: uC Connections in Buffered Mode

Note that depending upon the application, some uC connections may not be needed:

- IRQ\_0: if none of the relevant IRQ sources are used. In this case, leave floating.
- IRQ\_1: if none of the relevant IRQ sources are used. In this case, leave floating.
- MISO: if no read register access is needed and the chip is used in Tx mode only. In this case, pull up to VDD through a 100 kΩ resistor.

In addition, DATA pin (unused in buffered mode) should be pulled-up to VDD through a 100 kΩ resistor. Please refer to Table 13 for the SX1211's pin configuration.

### 5.4.6. Buffered Mode Example

- Configure all data processing related registers listed below appropriately. In this example we assume Sync word recognition is on and Fifo\_fill\_method=0.

		Tx	Rx	Description
<b>MCPParam</b>	Data_mode_x	X	X	Defines data operation mode (→Buffered)
	Fifo_size	X	X	Defines FIFO size
	Fifo_thresh	X	X	Defines FIFO threshold
<b>IRQParam</b>	Rx_stby_irq_0		X	Defines IRQ_0 source in Rx & Stby modes
	Rx_stby_irq_1		X	Defines IRQ_1 source in Rx & Stby modes
	Tx_irq_1	X		Defines IRQ_1 source in Tx mode
	Fifo_fill_method		X	Defines FIFO filling method
	Fifo_fill		X	Controls FIFO filling status
<b>RXParam</b>	Tx_start_irq_0	X		Defines Tx start condition and IRQ_0 source
	Sync_size		X	Defines Sync word size
<b>SYNCPParam</b>	Sync_tol		X	Defines the error tolerance on Sync word detection
	Sync_value		X	Defines Sync word value

Table 22: Relevant Configuration Registers in Buffered Mode (data processing related only)

#### Tx Mode:

- Program Tx start condition and IRQs: Start Tx when FIFO is not empty (Tx\_start\_irq\_0=1) and IRQ\_1 mapped to Tx\_done (Tx\_irq\_1=1)
- Go to Tx mode (and wait for Tx to be ready, see Figure 50)

- Write packet bytes into FIFO. Tx starts when the first byte is written (Tx\_start\_irq\_0=1). We assume the FIFO is being filled via SPI Data faster than being unfilled by SR.
- Wait for Tx\_done interrupt (+1 bit period)
- Go to Sleep mode

#### Rx Mode:

- Program Rx/Stby interrupts: IRQ\_0 mapped to /Fifoempty (Rx\_stby\_irq\_0=10) and IRQ\_1 mapped to Fifo\_threshold (Rx\_stby\_irq\_1=11). Configure Fifo\_thresh to an appropriate value (ex: to detect packet end if its length is known)
- Go to Rx mode (note that Rx is not ready immediately, Cf section 7.3.1).
- Wait for Fifo\_threshold interrupt (i.e. Sync word has been detected and FIFO filled up to the defined threshold).
- If it is packet end, go to Stby (SR's content is lost).
- Read packet bytes from FIFO until /Fifoempty goes low (or correct number of bytes is read).
- Go to Sleep mode.

onlinecomponents.com

## 5.5. Packet Mode

### 5.5.1. General Description

Similar to Buffered mode operation, in Packet mode the NRZ data to (from) the (de)modulator is not directly accessed by the uC but stored in the FIFO and accessed via the SPI Data interface.

In addition, the SX1211's packet handler performs several packet oriented tasks such as Preamble and Sync word generation, CRC calculation/check, whitening/dewhitening of data, address filtering, etc. This simplifies still further software and reduces uC overhead by performing these repetitive tasks within the RF chip itself.

Another important feature is ability to fill and empty the FIFO in Stby mode, ensuring optimum power consumption and adding more flexibility for the software.

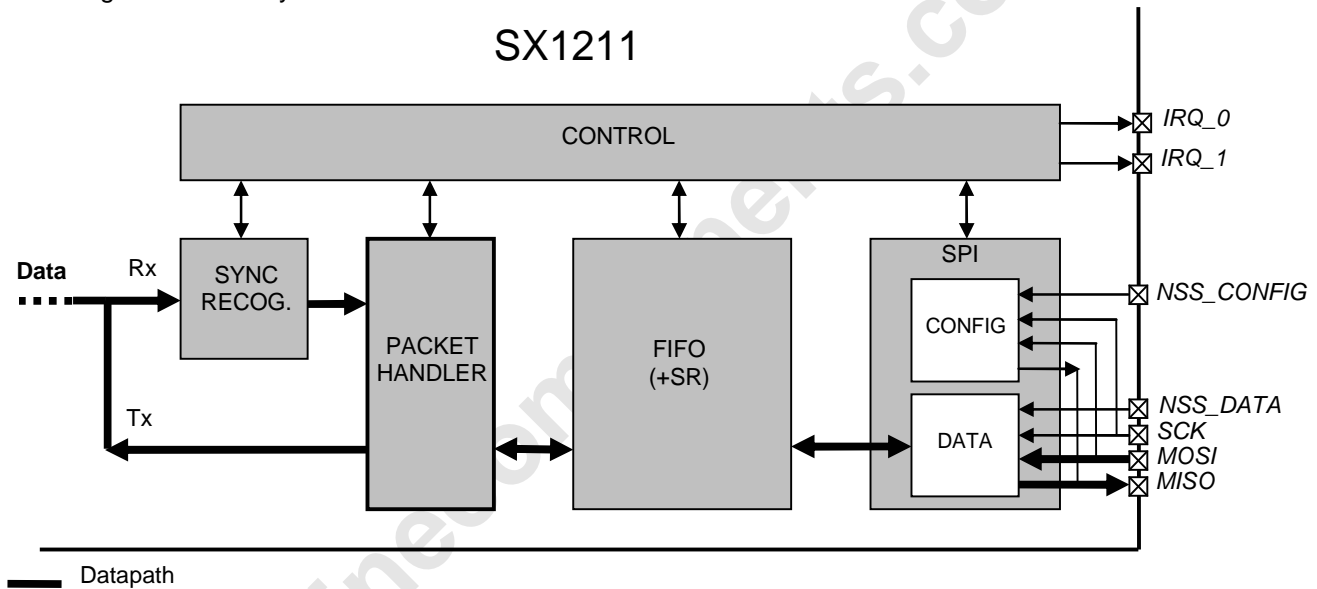

Figure 42: Packet Mode Conceptual View

Note that Bit Synchronizer and Sync word recognition are automatically enabled in Packet mode.

### 5.5.2. Packet Format

Two types of packet formats are supported: fixed length and variable length, selectable by the PKTParam\_Pkt\_format bit. The maximum size of the payload is limited by the size of the FIFO selected (16, 32, 48 or 64 bytes).

#### 5.5.2.1. Fixed Length Packet Format

In applications where the packet length is fixed in advance, this mode of operation may be of interest to minimize RF overhead (no length byte field is required). All nodes, whether Tx only, Rx only, or Tx/Rx should be programmed with the same packet length value.

The length of the payload is set by the PKTParam\_Payload\_length register and is limited by the size of the FIFO selected.

The length stored in this register relates only to the payload which includes the message and the optional address byte. In this mode, the payload must contain at least one byte, i.e. address or message byte.

An illustration of a fixed length packet is shown in Figure 43. It contains the following fields:

- Preamble (1010...).
- Sync word (Network ID).
- Optional Address byte (Node ID).
- Message data.
- Optional 2-bytes CRC checksum.

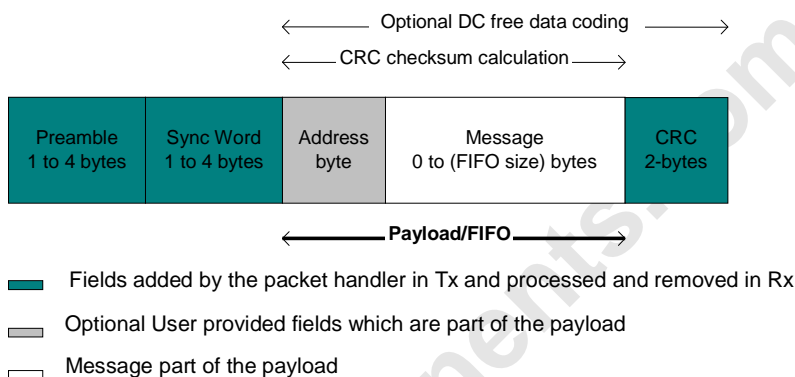

*Figure 43: Fixed Length Packet Format*

### 5.5.2.2. Variable Length Packet Format

This mode is necessary in applications where the length of the packet is not known in advance and can vary over time. It is then necessary for the transmitter to send the length information together with each packet in order for the receiver to operate properly.

In this mode the length of the payload, indicated by the length byte in Figure 44, is given by the first byte of the FIFO and is limited only by the width of the FIFO selected. Note that the length byte itself is not included in its calculation. In this mode, the payload must contain at least 2 bytes, i.e. length + address or message byte.

An illustration of a variable length packet is shown in Figure 44. It contains the following fields:

- Preamble (1010...).
- Sync word (Network ID).
- Length byte
- Optional Address byte (Node ID).
- Message data.
- Optional 2-bytes CRC checksum.

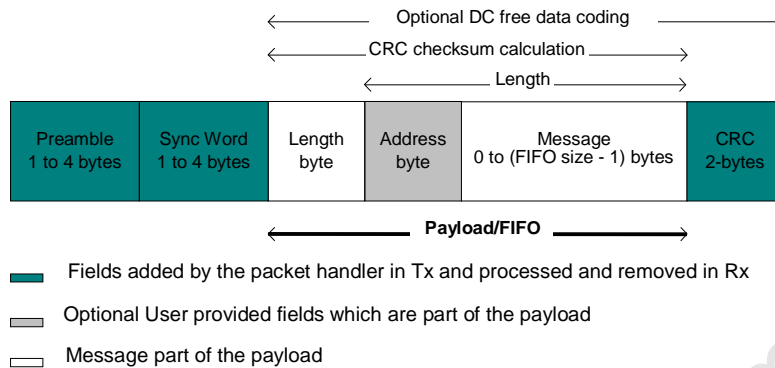

Figure 44: Variable Length Packet Format

### 5.5.3. Tx Processing

In Tx mode the packet handler dynamically builds the packet by performing the following operations on the payload available in the FIFO:

- Add a programmable number of preamble bytes
- Add a programmable Sync word
- Optionally calculating CRC over complete payload field (optional length byte + optional address byte + message) and appending the 2 bytes checksum.
- Optional DC-free encoding of the data (Manchester or whitening).

Only the payload (including optional address and length fields) is to be provided by the user in the FIFO.

Assuming that the chip is already in Tx mode then, depending on `IRQParam_Tx_start_irq_0` bit, packet transmission (starting with programmed preamble) will start either after the first byte is written into the FIFO (`Tx_start_irq_0=1`) or after the number of bytes written reaches the user defined threshold (`Tx_start_irq_0=0`). The FIFO can also be fully or partially filled in Stby mode via `PKTParam_Fifo_stby_access`. In this case, the start condition will only be checked when entering Tx mode.

At the end of the transmission (`Tx_done = 1`), the user must explicitly exit Tx mode if required. (e.g. back to Stby)

Note that while in Tx mode, before and after actual packet transmission (not enough bytes or `Tx_done`), additional preamble bytes are automatically sent to the modulator. When the start condition is met, the current additional preamble byte is completely sent before the transmission of the next packet (i.e. programmed preamble) is started.

### 5.5.4. Rx Processing

In Rx mode the packet handler extracts the user payload to the FIFO by performing the following operations:

- Receiving the preamble and stripping it off.
- Detecting the Sync word and stripping it off.
- Optional DC-free decoding of data.
- Optionally checking the address byte.
- Optionally checking CRC and reflecting the result on `CRC_status` bit and `CRC_OK` IRQ source.

Only the payload (including optional address and length fields) is made available in the FIFO.

`Payload_ready` and `CRC_OK` interrupts (the latter only if CRC is enabled) can be generated to indicate the end of the packet reception.

By default, if the CRC check is enabled and fails for the current packet, then the FIFO is automatically cleared and neither of the two interrupts are generated and new packet reception is started. This autoclear function can be disabled via PKTParam\_CRC\_autoclr bit and, in this case, even if CRC fails, the FIFO is not cleared and only Payload\_ready IRQ source is asserted.

Once fully received, the payload can also be fully or partially retrieved in Stby mode via PKTParam\_Fifo\_stby\_access. At the end of the reception, although the FIFO automatically stops being filled, it is still up to the user to explicitly exit Rx mode if required. (e.g. go to Stby to get payload). FIFO must be empty for a new packet reception to start.

### 5.5.5. Packet Filtering

SX1211's packet handler offers several mechanisms for packet filtering ensuring that only useful packets are made available to the uC, reducing significantly system power consumption and software complexity.

#### 5.5.5.1. Sync Word Based

Sync word filtering/recognition is automatically enabled in Packet mode. It is used for identifying the start of the payload and also for network identification. As previously described, the Sync word recognition block is configured (size, error tolerance, value) via RXParam\_Sync\_size, RXParam\_Sync\_tol and SYNCParam configuration registers. This information is used, both for appending Sync word in Tx, and filtering packets in Rx.

Every received packet which does not start with this locally configured Sync word is automatically discarded and no interrupt is generated.

When the Sync word is detected, payload reception automatically starts and Sync IRQ source is asserted.

#### 5.5.5.2. Address Based

Address filtering can be enabled via the PKTParam\_Adrs\_filt bits. It adds another level of filtering, above Sync word, typically useful in a multi-node networks where a network ID is shared between all nodes (Sync word) and each node has its own ID (address).

Three address based filtering options are available:

- Adrs\_filt = 01: Received address field is compared with internal register Node\_Adrs. If they match then the packet is accepted and processed, otherwise it is discarded.
- Adrs\_filt = 10: Received address field is compared with internal register Node\_Adrs and the constant 0x00. If either is a match, the received packet is accepted and processed, otherwise it is discarded. This additional check with a constant is useful for implementing broadcast in a multi-node networks.
- Adrs\_filt = 11: Received address field is compared with internal register Node\_Adrs and the constants 0x00 & 0xFF. If any of the three matches, then the received packet is accepted and processed, otherwise it is discarded. These additional checks with constants are useful for implementing broadcast commands of all nodes.

Please note that the received address byte, as part of the payload, is not stripped off the packet and is made available in the FIFO. In addition, Node\_Adrs and Adrs\_filt only apply to Rx. On Tx side, if address filtering is expected, the address byte should simply be put into the FIFO like any other byte of the payload.

#### 5.5.5.3. Length Based

In variable length Packet mode, PKTParam\_Payload\_length must be programmed with the maximum length permitted. If received length byte is smaller than this maximum then the packet is accepted and processed, otherwise it is discarded.



Please note that the received length byte, as part of the payload, is not stripped off the packet and is made available in the FIFO.

To disable this function the user should set the value of the PKTParam\_Payload\_length to the value of the FIFO size selected.

**5.5.5.4. CRC Based**

The CRC check is enabled by setting bit PKTParam\_CRC\_on. It is used for checking the integrity of the message.

- On Tx side a two byte CRC checksum is calculated on the payload part of the packet and appended to the end of the message.
- On Rx side the checksum is calculated on the received payload and compared with the two checksum bytes received. The result of the comparison is stored in the PKTParam\_CRC\_status bit and CRC\_OK IRQ source.

By default, if the CRC check fails then the FIFO is automatically cleared and no interrupt is generated. This filtering function can be disabled via PKTParam\_CRC\_autoclr bit and in this case, even if CRC fails, the FIFO is not cleared and only Payload\_ready interrupt goes high. Please note that in both cases, the two CRC checksum bytes are stripped off by the packet handler and only the payload is made available in the FIFO.

The CRC is based on the CCITT polynomial as shown in Figure 45. This implementation also detects errors due to leading and trailing zeros.

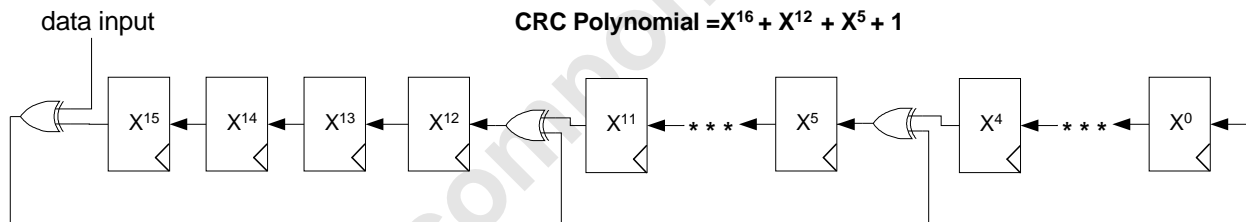

Figure 45: CRC Implementation

**5.5.6. DC-Free Data Mechanisms**

The payload to be transmitted may contain long sequences of 1's and 0's, which introduces a DC bias in the transmitted signal. The radio signal thus produced has a non uniform power distribution over the occupied channel bandwidth. It also introduces data dependencies in the normal operation of the demodulator. Thus it is useful if the transmitted data is random and DC free.

For such purposes, two techniques are made available in the packet handler: Manchester encoding and data whitening. Please note that only one of the two methods should be enabled at a time.

**5.5.6.1. Manchester Encoding**

Manchester encoding/decoding is enabled by setting bit PKTParam\_Manchester\_on and can only be used in Packet mode.

The NRZ data is converted to Manchester code by coding '1' as "10" and '0' as "01".

In this case, the maximum chip rate is the maximum bit rate given in the specifications section and the actual bit rate is half the chip rate.

Manchester encoding and decoding is only applied to the payload and CRC checksum while preamble and Sync word are kept NRZ. However, the chip rate from preamble to CRC is the same and defined by MCPParam\_BR (Chip Rate = Bit Rate NRZ = 2 x Bit Rate Manchester).

Manchester encoding/decoding is thus made transparent for the user, who still provides/retrieves NRZ data to/from the FIFO.

		1/BR ...Sync						1/BR Payload...											
RF chips @ BR	...	1	1	1	0	1	0	0	1	0	0	1	0	1	1	0	1	0	...
User/NRZ bits Manchester OFF	...	1	1	1	0	1	0	0	1	0	0	1	0	1	1	0	1	0	...
User/NRZ bits Manchester ON	...	1	1	1	0	1	0	0	1	0	0	1	0	1	1	0	1	0	...

Figure 46: Manchester Encoding/Decoding

### 5.5.6.2. Data Whitening

Another technique called whitening or scrambling is widely used for randomizing the user data before radio transmission. The data is whitened using a random sequence on the Tx side and de-whitened on the Rx side using the same sequence. Comparing to Manchester technique it has the advantage of keeping NRZ datarate i.e. actual bit rate is not halved.

The whitening/de-whitening process is enabled by setting bit PKTParam\_Whitening\_on. A 9-bit LFSR is used to generate a random sequence. The payload and 2-byte CRC checksum is then XORed with this random sequence as shown in Figure 47. The data is de-whitened on the receiver side by XORing with the same random sequence.

Payload whitening/de-whitening is thus made transparent for the user, who still provides/retrieves NRZ data to/from the FIFO.

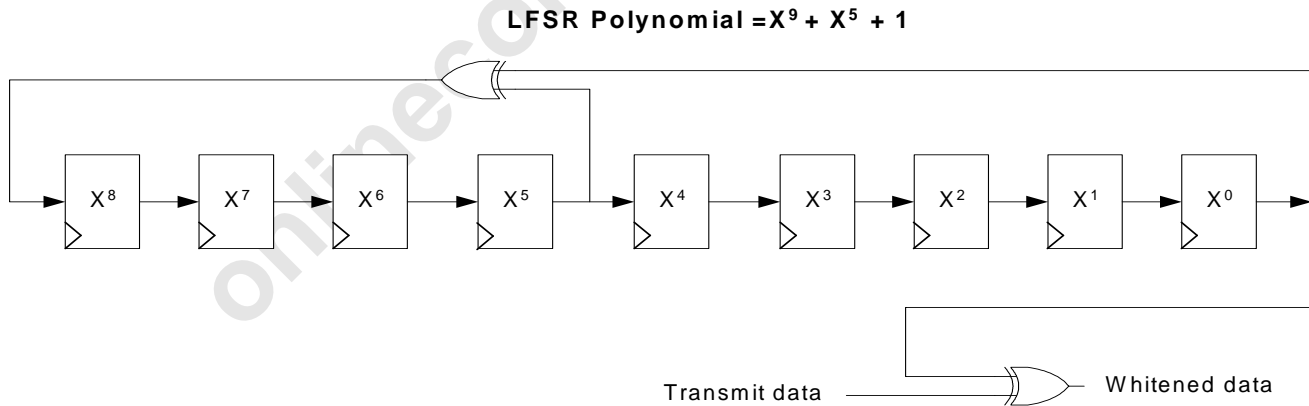

Figure 47: Data Whitening

### 5.5.7. Interrupt Signal Mapping

Tables below give the description of the interrupts available in Packet mode.

Table 23: Interrupt Mapping in Rx and Stby in Packet Mode

	Rx_stby_irq_x	Rx	Stby
<b>IRQ_0</b>	00 (d)	Payload_ready	-
	01	Write_byte	-
	10	/Fifoempty	/Fifoempty
	11	Sync or Adrs_match*	-
<b>IRQ_1</b>	00 (d)	CRC_OK	-
	01	Fifofull	Fifofull
	10	RSSI	-
	11	Fifo_threshold	Fifo_threshold

\*The latter if Address filtering is enabled

		Tx
<b>IRQ_0</b>	Tx_start_irq_0=0 (d)	Fifo_threshold
	Tx_start_irq_0=1	/Fifoempty
<b>IRQ_1</b>	Tx_irq_1=0 (d)	Fifofull
	Tx_irq_1=1	Tx_done

Table 24: Interrupt Mapping in Tx Packet Mode

### 5.5.8. uC Connections

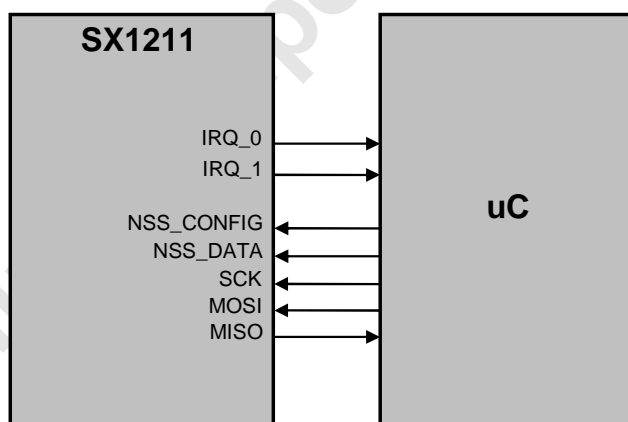

Figure 48: uC Connections in Packet Mode

Note that depending upon the application, some uC connections may not be needed:

- IRQ\_0: if none of the relevant IRQ sources are used. In this case, leave floating.
- IRQ\_1: if none of the relevant IRQ sources are used. In this case, leave floating.
- MISO: if no read register access is needed and the chip is used in Tx mode only. In this case, pull up to VDD through a 100 kΩ resistor.

In addition, DATA pin (unused in packet mode) should be pulled-up to VDD through a 100 kΩ resistor. Please refer to Table 13 for the SX1211's pin configuration.

### 5.5.9. Packet Mode Example

- Configure all data processing related registers listed below appropriately. In this example we assume CRC is enabled with autoclear on.

Table 25: Relevant Configuration Registers in Packet Mode (data processing related only)

		Tx	Rx	Description
MCPParam	Data_mode_x	X	X	Defines data operation mode (→Packet)
	Fifo_size	X	X	Defines FIFO size
	Fifo_thresh	X	X	Defines FIFO threshold
IRQParam	Rx_stby_irq_0		X	Defines IRQ_0 source in Rx & Stby modes
	Rx_stby_irq_1		X	Defines IRQ_1 source in Rx & Stby modes
	Tx_irq_1	X		Defines IRQ_1 source in Tx mode
	Tx_start_irq_0	X		Defines Tx start condition and IRQ_0 source
RXParam	Sync_size	X	X	Defines Sync word size
	Sync_tol		X	Defines the error tolerance on Sync word detection
SYNCPParam	Sync_value	X	X	Defines Sync word value
PKTPParam	Manchester_on	X	X	Enables Manchester encoding/decoding
	Payload_length	X <sup>(1)</sup>	X	Length in fixed format, max Rx length in variable format
	Node_adrs		X	Defines node address for Rx address filtering
	Pkt_format	X	X	Defines packet format (fixed or variable length)
	Preamble_size	X		Defines the size of preamble to be transmitted
	Whitening_on	X	X	Enables whitening/de-whitening process
	CRC_on	X	X	Enables CRC calculation/check
	Adrs_filt		X	Enables and defines address filtering
	CRC_autoclr		X	Enables FIFO autoclear if CRC failed
Fifo_stby_access	X	X	Defines FIFO access in Stby mode	

<sup>(1)</sup>fixed format only

#### Tx Mode:

- Program Tx start condition and IRQs: Start Tx when FIFO not empty (Tx\_start\_irq\_0=1) and IRQ\_1 mapped to Tx\_done (Tx\_irq\_1=1)
- Go to Stby mode
- Write all payload bytes into FIFO (Fifo\_stby\_access=0, Stby interrupts can be used if needed)
- Go to Tx mode. When Tx is ready (automatically handled) Tx starts (Tx\_start\_irq\_0=1).
- Wait for Tx\_done interrupt (+1 bit period)
- Go to Sleep mode

#### Rx Mode:

- Program Rx/Stby interrupts: IRQ\_0 mapped to /Fifoempty (Rx\_stby\_irq\_0=10) and IRQ\_1 mapped to CRC\_OK (Rx\_stby\_irq\_1=00)
- Go to Rx (note that Rx is not ready immediately, see section 7.3.1)
- Wait for CRC\_OK interrupt
- Go to Stby
- Read payload bytes from FIFO until /Fifoempty goes low. (Fifo\_stby\_access =1)
- Go to Sleep mode

### 5.5.10. Additional Information

If the number of bytes filled for transmission is greater than the actual length of the packet to be transmitted and Tx\_start\_irq\_0 = 1, then the FIFO is cleared after the packet has been transmitted. Thus the extra bytes in the

FIFO are lost. On the other hand if Tx\_start\_irq\_0 = 0 then the extra bytes are kept into the FIFO. This opens up the possibility of transmitting more than one packet by filling the FIFO with multiple packet messages.

It is not possible to receive multiple packets. Once a packet has been received and filled into the FIFO all its content needs to be read i.e. the FIFO must be empty for a new packet reception to be initiated.

The Payload\_ready interrupt goes high when the last payload byte is available in the FIFO and remains high until all its data are read. Similar behavior is applicable to Adrs\_match and CRC\_OK interrupts.

The CRC result is available in the CRC\_status bit as soon as the CRC\_successful and Payload\_ready interrupt sources are triggered. In Rx mode, CRC\_status is cleared when the complete payload has been read from the FIFO. If the payload is read in Stby mode, then CRC\_status is cleared when the user goes back to Rx mode and a new Sync word is detected.

The Fifo\_fill\_method and Fifo\_fill bits don't have any meaning in the Packet mode and should be set to their default values only.

onlinecomponents.com

## 6. Configuration and Status Registers

### 6.1. General Description

Table 26 sums-up the control and status registers of the SX1211:

Table 26: Registers List

Name	Size	Address	Description
MCPParam	13 x 8	0 - 12	Main parameters common to transmit and receive modes
IRQParam	3 x 8	13 - 15	Interrupt registers
RXParam	6 x 8	16 - 21	Receiver parameters
SYNCPParam	4 x 8	22 - 25	Pattern
TXParam	1 x 8	26	Transmitter parameters
OSCPParam	1 x 8	27	Crystal oscillator parameters
PKTPParam	4 x 8	28 - 31	Packet handler parameters

### 6.2. Main Configuration Register - MCPParam

The detailed description of the MCPParam register is given in Table 27.

Table 27: MCPParam Register Description

Name	Bits	Address (d)	RW	Description
Chip_mode	7-5	0	r/w	Transceiver mode: 000 → sleep mode - Sleep 001 → stand-by mode - Stby (d) 010 → frequency synthesizer mode - FS 011 → receive mode - Rx 100 → transmit mode - Tx
Freq_band	4-3	0	r/w	Frequency band: 00 → 902 – 915 MHz 01 → 915 – 928 MHz (d) 10 → 950 – 960 MHz or 863 - 870 MHz (Application Circuit dependant)
VCO_trim	2-1	0	r/w	Fine VCO trimming: 00 → Vtune determined by tank inductors values (d) 01 → Vtune + 60 mV typ. 10 → Vtune + 120 mV typ. 11 → Vtune + 180 mV typ.
RPS_select	0	0	r/w	Selection between the two sets of frequency dividers of the PLL, Ri/Pi/Si 0 → R1/P1/S1 selected(d) 1 → R2/P2/S2 selected
Modul_select	7-6	1	r/w	Modulation type: 01 → OOK 10 → FSK (d)
Data_mode_0	5	1	r/w	Data operation mode LSB (refer to Data_Mode_1 (Bit 2 Addr 1))
OOK_thresh_type	4-3	1	r/w	OOK demodulator threshold type: 00 → fixed threshold mode 01 → peak mode (d) 10 → average mode 11 → reserved

Data_mode_1	2	1	r/w	Data operation mode's MSB. Cf. Data_mode_0 (Bit 5 Addr 1)		
				Data_mode_1 Bit 2 addr 1	Data_mode_0 Bit 5 addr 1	Data Operation Mode
				0	0	Continuous (d)
				0	1	Buffered
				1	x	Packet
IF_gain	1-0	1	r/w	Gain on the IF chain: 00 → maximal gain (0dB) (d) 01 → -4.5 dB 10 → -9dB 11 → -13.5 dB		
Freq_dev	7-0	2	r/w	Single side frequency deviation in FSK Transmit mode: Refer to sections 3.3.4 and 3.3.5 $F_{dev} = \frac{f_{XTAL}}{32 \cdot (D + 1)}, 0 \leq D \leq 255$ , where D is the value in the register. (d): D = "00000011" => Fdev = 100 kHz		
Res	7	3	r/w	Reserved (d): "0"		
BR	6-0	3	r/w	Bit Rate = $\frac{f_{XTAL}}{64 \cdot (C + 1)}$ , 0 ≤ C ≤ 127, where C is the value in the register. (d): C = "0000111" => Bit Rate = 25 kb/s NRZ		
OOK_floor_thresh	7-0	4	r/w	Floor threshold in OOK Rx mode. By default 6 dB. (d): "00001100" assuming 0.5 dB RSSI step		
Fifo_size	7:6	5	r/w	FIFO size selection: 00 → 16 bytes (d) 01 → 32 bytes 10 → 48 bytes 11 → 64 bytes		
Fifo_thresh	5-0	5	r/w	FIFO threshold for interrupt source (Cf section 5.2.2.3) (d): B = "001111"		
R1	7-0	6	r/w	R counter, active when RPS_select="0" (d): 77h; default values of R1, P1, S1 generate 915.0 MHz in FSK mode		
P1	7-0	7	r/w	P counter, active when RPS_select="0" (d): 64h; default values of R1, P1, S1 generate 915.0 MHz in FSK mode		
S1	7-0	8	r/w	S counter, active when RPS_select="0" (d): 32h; default values of R1, P1, S1 generate 915.0 MHz in FSK mode		
R2	7-0	9	r/w	R counter, active when RPS_select="1" (d): 74h; default values of R2, P2, S2 generate 920.0 MHz in FSK mode		
P2	7-0	10	r/w	P counter, active when RPS_select="1" (d): 62h; default values of R2, P2, S2 generate 920.0 MHz in FSK mode		
S2	7-0	11	r/w	S counter, active when RPS_select="1" (d): 32h; default values of R2, P2, S2 generate 920.0 MHz in FSK mode		
Res	7-5	12	r/w	Reserved (d): "001"		
PA_ramp	4-3	12	r/w	Ramp control of the rise and fall times of the Tx PA regulator output voltage in OOK mode: 00 → 3us 01 → 8.5 us 10 → 15 us 11 → 23 us (d)		
Res	2-0	12	r/w	Reserved (d): "000"		

### 6.3. Interrupt Configuration Parameters - IRQParam

The detailed description of the IRQParam register is given in Table 28.

Table 28: IRQParam Register Description

Name	Bits	Address (d)	RW	Description
Rx_stby_irq_0	7-6	13	r/w	IRQ_0 source in Rx and Standby modes: If Data_mode(1:0) = 00 (Continuous mode): 00 → Sync (d) 01 → RSSI 10 → Sync 11 → Sync If Data_mode(1:0) = 01 (Buffered mode): 00 → - (d) 01 → Write_byte 10 → /Fifoempty* 11 → Sync If Data_mode(1:0) = 1x (Packet mode): 00 → Payload_ready (d) 01 → Write_byte 10 → /Fifoempty* 11 → Sync or Adrs_match (the latter if address filtering is enabled)  *also available in Standby mode (Cf sections 5.4.4 and 5.5.7)
Rx_stby_irq_1	5-4	13	r/w	IRQ_1 source in Rx and Standby modes: If Data_mode(1:0) = 00 (Continuous mode): xx → DCLK If Data_mode(1:0) = 01 (Buffered mode): 00 → - (d) 01 → Fifofull* 10 → RSSI 11 → Fifo_threshold* If Data_mode(1:0) = 1x (Packet mode): 00 → CRC_ok (d) 01 → Fifofull* 10 → RSSI 11 → Fifo_threshold*  *also available in Standby mode (Cf sections 5.4.4 and 5.5.7)
Tx_irq_1	3	13	r/w	IRQ_1 source in Tx mode: If Data_mode(1:0) = 00 (Continuous mode): x → DCLK If Data_mode(1:0) = 01 (Buffered mode) or 1x (Packet mode): 0 → Fifofull (d) 1 → Tx_done
Fifofull	2	13	r	Fifofull IRQ source Goes high when FIFO is full.
/Fifoempty	1	13	r	/Fifoempty IRQ source Goes low when FIFO is empty
Fifo_overrun_clr	0	13	r/w/ c	Goes high when an overrun error occurred. Writing a 1 clears flag and FIFO
Fifo_fill_method	7	14	r/w	FIFO filling method (Buffered mode only):



				0 → Automatically starts when a sync word is detected (d) 1 → Manually controlled by Fifo_fill
Fifo_fill	6	14	r/w/ c	FIFO filling status/control (Buffered mode only): <ul style="list-style-type: none"> <li>▪ If Fifo_fill_method = '0': (d)</li> </ul> Goes high when FIFO is being filled (sync word has been detected) Writing '1' clears the bit and waits for a new sync word (if Fifo_overrun_clr=0) <ul style="list-style-type: none"> <li>▪ If Fifo_fill_method = '1':</li> </ul> 0 → Stop filling the FIFO 1 → Start filling the FIFO
Tx_done	5	14	r	Tx_done IRQ source Goes high when the last bit has left the shift register.
Tx_start_irq_0	4	14	r/w	Tx start condition and IRQ_0 source: <ul style="list-style-type: none"> <li>▪ If Data_mode(1:0) = 01 (Buffered mode):</li> </ul> 0 → Tx starts if FIFO is full, IRQ_0 mapped to /Fifoempty (d) 1 → Tx starts if FIFO is not empty, IRQ_0 mapped to /Fifoempty <ul style="list-style-type: none"> <li>▪ If Data_mode(1:0) = 1x (Packet mode):</li> </ul> 0 → Start transmission when the number of bytes in FIFO is greater than or equal to the threshold set by MCPParam_Fifo_thresh parameter (Cf section 5.2.2.3), IRQ_0 mapped to Fifo_threshold (d) 1 → Tx starts if FIFO is not empty, IRQ_0 mapped to /Fifoempty
Res	3	14	r/w	(d): "0", should be set to "1". Note: "0" disables the RSSI IRQ source. It can be left enabled at any time, and the user can choose to map this interrupt to IRQ0/IRQ1 or not.
RSSI_irq	2	14	r/w/ c	RSSI IRQ source: Goes high when a signal above RSSI_irq_thresh is detected Writing '1' clears the bit
PLL_locked	1	14	r/w/ c	PLL status: 0 → not locked 1 → locked Writing a '1' clears the bit
PLL_lock_en	0	14	r/w	PLL_lock detect flag mapped to pin 23: 0 → Lock detect disabled, pin 23 is High-Z 1 → Lock detect enabled(d)
RSSI_irq_thresh	7-0	15		RSSI threshold for interrupt (coded as RSSI) (d): "00000000"

## 6.4. Receiver Configuration parameters - RXParam

The detailed description of the RXParam register is given in Table 29.

Table 29: RXParam Register Description

Name	Bits	Address (d)	RW	Description
PassiveFilt	7-4	16	r/w	Typical single sideband bandwidth of the passive low-pass filter. PassiveFilt = 0000 → 65 kHz 0001 → 82 kHz 0010 → 109 kHz 0011 → 137 kHz 0100 → 157 kHz 0101 → 184 kHz 0110 → 211 kHz 0111 → 234 kHz 1000 → 262 kHz 1001 → 321 kHz 1010 → 378 kHz (d) 1011 → 414 kHz 1100 → 458 kHz 1101 → 514 kHz 1110 → 676 kHz 1111 → 987 kHz
ButterFilt	3-0	16	r/w	Sets the receiver bandwidth. For BW information please refer to sections 3.4.5 (FSK) and 3.4.6 (OOK). $f_c = f_0 + 200kHz \cdot \frac{f_{xtal} MHz}{12.8MHz} \cdot \frac{1 + Val(ButterFilt)}{8}$ (d): "0011" => $f_c - f_0 = 100$ kHz
PolypFilt_center	7-4	17	r/w	Central frequency of the polyphase filter (100kHz recommended): $f_0 = 200kHz \cdot \frac{F_{xtal} MHz}{12.8MHz} \cdot \frac{1 + Val(PolypFilt\_center)}{8}$ (d): "0011" => $f_0 = 100$ kHz
Res	3-0	17	r/w	Reserved (d): "1000"
PolypFilt_on	7	18	r/w	Enable of the polyphase filter, in OOK Rx mode: 0 → off (d) 1 → on
Bitsync_off	6	18	r/w	Bit synchronizer: control in Continuous Rx mode: 0 → on (d) 1 → off
Sync_on	5	18	r/w	Sync word recognition: 0 → off (d) 1 → on
Sync_size	4-3	18	r/w	Sync word size: 00 → 8 bits 01 → 16 bits 10 → 24 bits 11 → 32 bits (d)
Sync_tol	2-1	18	r/w	Number of errors tolerated in the Sync word recognition: 00 → 0 error (d) 01 → 1 error 10 → 2 errors 11 → 3 errors
Res	0	18	r/w	Reserved (d): "0"

Name	Bits	Address (d)	RW	Description
Res	7-0	19	r/w	Reserved (d): "00000111"
RSSI_val	7-0	20	r	RSSI output, 0.5 dB / bit Note: READ-ONLY (not to be written)
OOK_thresh_step	7-5	21	r/w	Size of each decrement of the RSSI threshold in the OOK demodulator 000 → 0.5 dB (d)    100 → 3.0 dB 001 → 1.0 dB        101 → 4.0 dB 010 → 1.5 dB        110 → 5.0 dB 011 → 2.0 dB        111 → 6.0 dB
OOK_thresh_dec_period	4-2	21	r/w	Period of decrement of the RSSI threshold in the OOK demodulator: 000 → once in each chip period (d) 001 → once in 2 chip periods 010 → once in 4 chip periods 011 → once in 8 chip periods 100 → twice in each chip period 101 → 4 times in each chip period 110 → 8 times in each chip period 111 → 16 times in each chip period
OOK_avg_thresh_cutoff	1-0	21	r/w	Cutoff frequency of the averaging for the average mode of the OOK threshold in demodulator 00 → $f_c \approx BR / 8 \cdot \pi$ (d) 01 → Reserved 10 → Reserved 11 → $f_c \approx BR / 32 \cdot \pi$

## 6.5. Sync Word Parameters - SYNCParam

The detailed description of the SYNCParam register is given in Table 30.

Table 30: SYNCParam Register Description

Name	Bits	Address (d)	RW	Description
Sync_value(31:24)	7-0	22	r/w	1 <sup>st</sup> Byte of Sync word (d): "00000000"
Sync_value(23:16)	7-0	23		2 <sup>nd</sup> Byte of Sync word (only used if Sync_size ≠ 00) (d): "00000000"
Sync_value(15:8)	7-0	24		3 <sup>rd</sup> Byte of Sync word (only used if Sync_size = 1x) (d): "00000000"
Sync_value(7:0)	7-0	25		4 <sup>th</sup> Byte of Sync word (only used if Sync_size = 11) (d): "00000000"

## 6.6. Transmitter Parameters - TXParam

The detailed description of the TXParam register is given in Table 31.

Table 31: TXParam Register Description

Name	Bits	Address (d)	RW	Description
InterpFilt	7-4	26	r/w	Tx Interpolation filter cut off frequency: $f_c = 200\text{kHz} \cdot \frac{F_{xtal}\text{MHz}}{12.8\text{MHz}} \cdot \frac{1 + \text{Val}(\text{InterpFiltTx})}{8}$ (d): "0111" => $f_c = 200\text{ kHz}$
Pout	3-1	26	r/w	Tx output power (1 step $\approx$ 3 dB): 000 $\rightarrow$ 13 dBm 001 $\rightarrow$ 13 dBm -1 step (d) 010 $\rightarrow$ 13 dBm - 2 steps 011 $\rightarrow$ 13 dBm - 3 steps 100 $\rightarrow$ 13 dBm - 4 steps 101 $\rightarrow$ 13 dBm - 5 steps 110 $\rightarrow$ 13 dBm - 6 steps 111 $\rightarrow$ 13 dBm - 7 steps
Res	0	26	r/w	Reserved (d): "0"

## 6.7. Oscillator Parameters - OSCParam

The detailed description of the OSCParam register is given in Table 32.

Table 32: OSCParam Register Description

Name	Bits	Address (d)	RW	Description
Clkout_on	7	27	r/w	Clkout control 0 $\rightarrow$ Disabled 1 $\rightarrow$ Enabled, Clk frequency set by Clkout_freq (d)
Clkout_freq	6-2	27	r/w	Frequency of the signal provided on CLKOUT: $f_{clkout} = f_{xtal}$ if Clkout_freq = "00000" $f_{clkout} = \frac{f_{xtal}}{2 \cdot \text{Clkout\_freq}}$ otherwise (d): 01111 (= 427 kHz)
Res	1-0	27	r/w	Reserved (d): "00"

## 6.8. Packet Handling Parameters – PKTParam

The detailed description of the PKTParam register is given in Table 33.

Table 33: PKTParam Register Description

Name	Bits	Address (d)	RW	Description
Manchester_on	7	28	r/w	Enable Manchester encoding/decoding: 0 → off (d) 1 → on
Payload_length	6-0	28	r/w	If Pkt_format=0, payload length. If Pkt_format=1, max length in Rx, not used in Tx. (d): "000000"
Node_adrs	7-0	29	r/w	Node's local address for filtering of received packets. (d): 00h
Pkt_format	7	30	r/w	Packet format: 0 → fixed length (d) 1 → variable length
Preamble_size	6-5	30	r/w	Size of the preamble to be transmitted: 00 → 1 byte 01 → 2 bytes 10 → 3 bytes (d) 11 → 4 bytes
Whitening_on	4	30	r/w	Whitening/dewhitening process: 0 → off (d) 1 → on
CRC_on	3	30	r/w	CRC calculation/check: 0 → off 1 → on (d)
Adrs_filt	2-1	30	r/w	Address filtering of received packets: 00 → off (d) 01 → Node_adrs accepted, else rejected. 10 → Node_adrs & 0x00 accepted, else rejected. 11 → Node_adrs & 0x00 & 0xFF accepted, else rejected.
CRC_status	0	30	r	CRC check result for current packet (READ ONLY): 0 → Fail 1 → Pass
CRC_autoclr	7	31	r/w	FIFO auto clear if CRC failed for current packet: 0 → on (d) 1 → off
Fifo_stby_access	6	31	r/w	FIFO access in standby mode: 0 → Write (d) 1 → Read
Res	5-0	31	r/w	Reserved (d): "000000"

## 7. Application Information

### 7.1. Crystal Resonator Specification

Table 34 shows the crystal resonator specification for the crystal reference oscillator circuit of the SX1211. This specification covers the full range of operation of the SX1211 and is employed in the reference design (see section 7.5.3).

Table 34: Crystal Resonator Specification

Name	Description	Min.	Typ.	Max.	Unit
Fxtal	Nominal frequency	9	12.800	15	MHz
Cload	Load capacitance for Fxtal	10	15	16.5	pF
Rm	Motional resistance	-	-	100	ohms
Co	Shunt capacitance	1	-	7	pF
$\Delta$ Fxtal	Calibration tolerance at 25+/-3°C	-15	-	+15	ppm
$\Delta$ Fxtal( $\Delta$ T)	Stability over temperature range [-40°C ; +85°C]	-2 0	-	+20	ppm
$\Delta$ Fxtal( $\Delta$ t)	Ageing tolerance in first 5 years	-2	-	+2	ppm/year

Note that the initial frequency tolerance, temperature stability and ageing performance should be chosen in accordance with the target operating temperature range and the receiver bandwidth selected.

### 7.2. Software for Frequency Calculation

The R1, P1, S1, and R2, P2, S2 dividers are configured over the SPI interface and programmed by 8 bits each, at addresses 6 to 11. The frequency pairs may hence be switched in a single SPI cycle.

#### 7.2.1. GUI

To aid the user with calculating appropriate R, P and S values, software is available to perform the frequency calculation. The SX1211 PLL frequency Calculator Software can be downloaded from the Semtech website.

#### 7.2.2. .dll for Automatic Production Bench

The Dynamically Linked Library (DLL) used by the software to perform these calculations is also provided, free of charge, to users, for inclusion in automatic production testing. Key benefits of this are:

- No hand trimming of the reference frequency required: the actual reference frequency of the Device Under Test (DUT) can be easily measured (e.g. from the CLKOUT output of the SX1211) and the tool will calculate the best frequencies to compensate for the crystal initial error.
- Channel plans can be calculated and stored in the application's memory, then adapted to the actual crystal oscillator frequency.

### 7.3. Switching Times and Procedures

As an ultra-low power device, the SX1211 can be configured for low minimum average power consumption. To minimize consumption the following optimized transitions between modes are shown.

### 7.3.1. Optimized Receive Cycle

The lowest-power Rx cycle is the following:

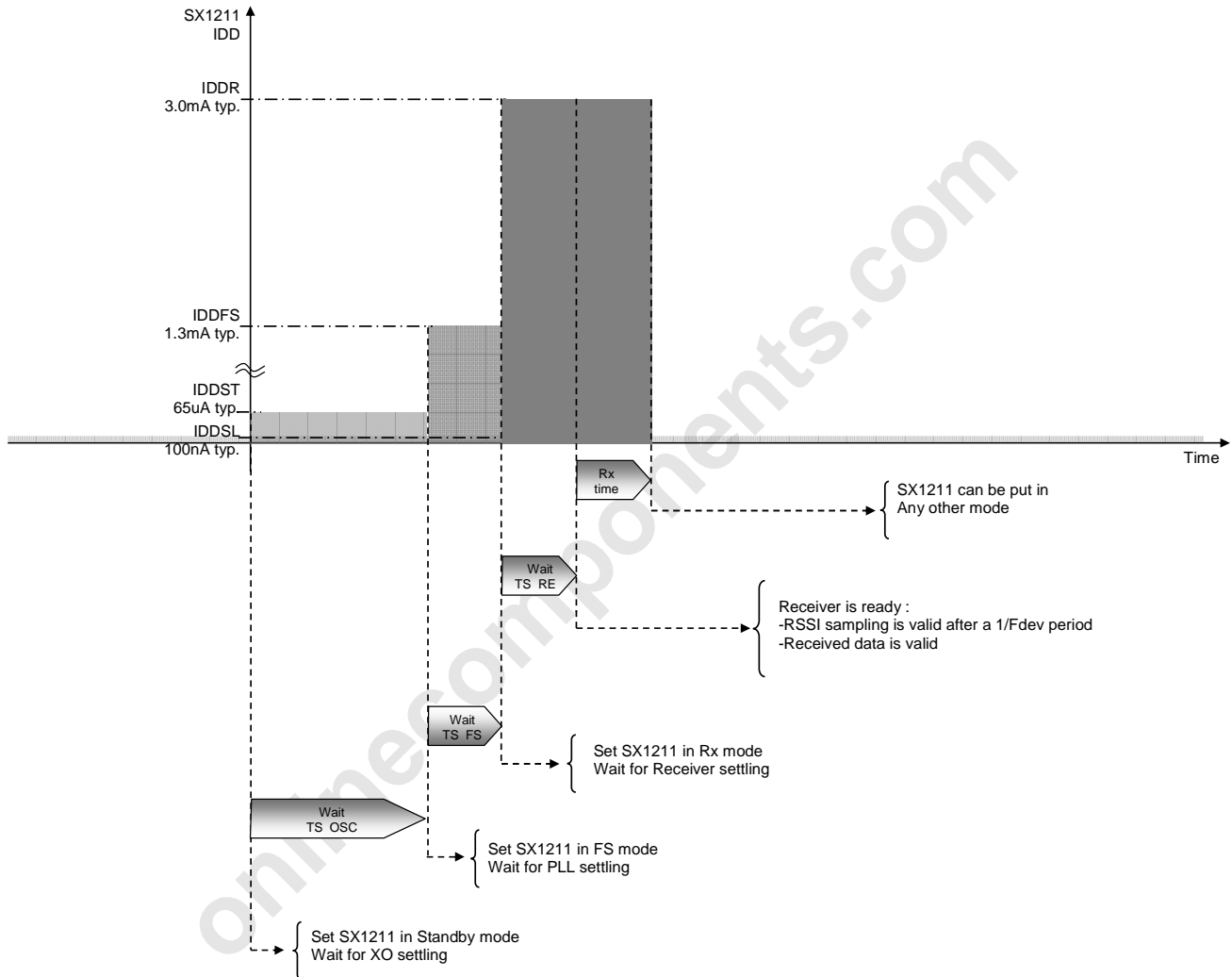

Figure 49: Optimized Rx Cycle

Note: If the lock detect indicator is available on an external interrupt pin of the companion uC, it can be used to optimize TS\_FS, without having to wait the maximum specified TS\_FS.

**7.3.2. Optimized Transmit Cycle**

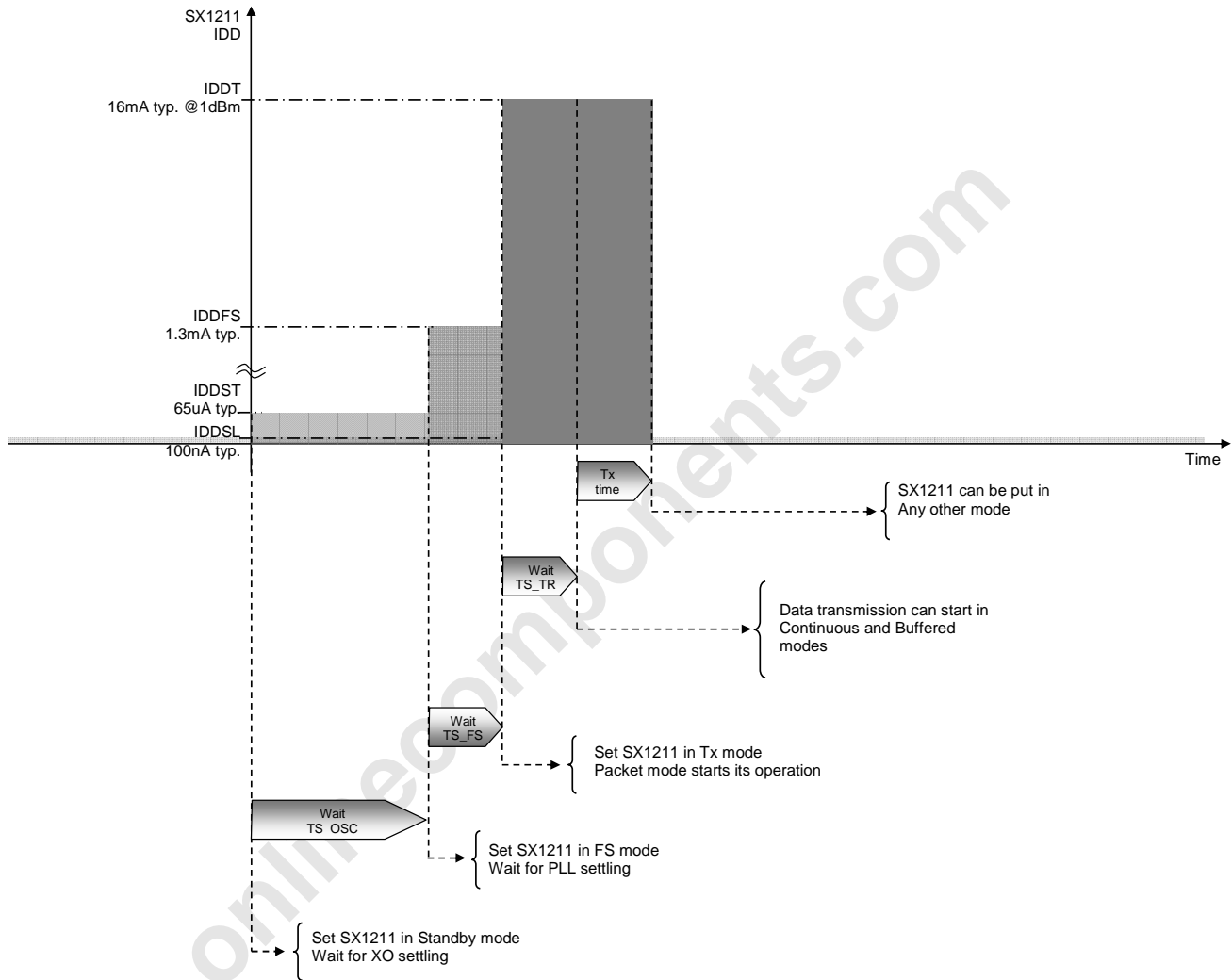

Figure 50: Optimized Tx Cycle

Note: As stated in the preceding section, TS\_FS time can be improved by using the external lock detector pin as external interrupt trigger.



### 7.3.3. Transmitter Frequency Hop Optimized Cycle

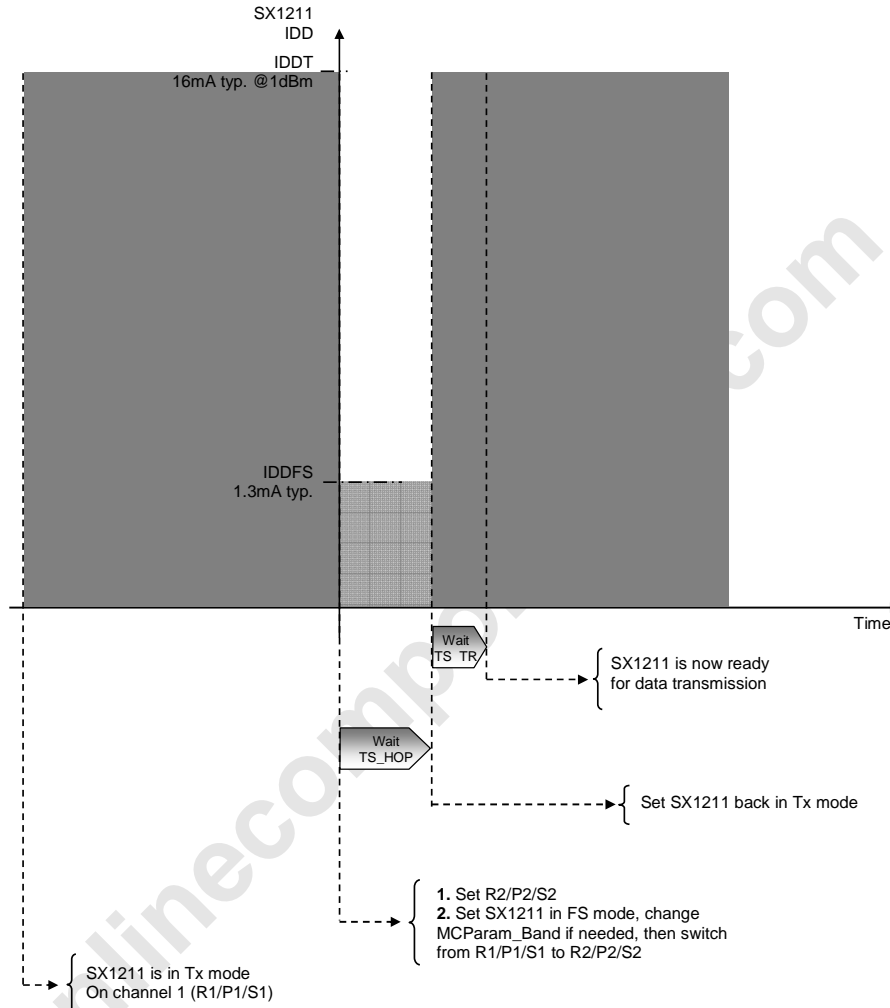

Figure 51: Tx Hop Cycle

### 7.3.4. Receiver Frequency Hop Optimized Cycle

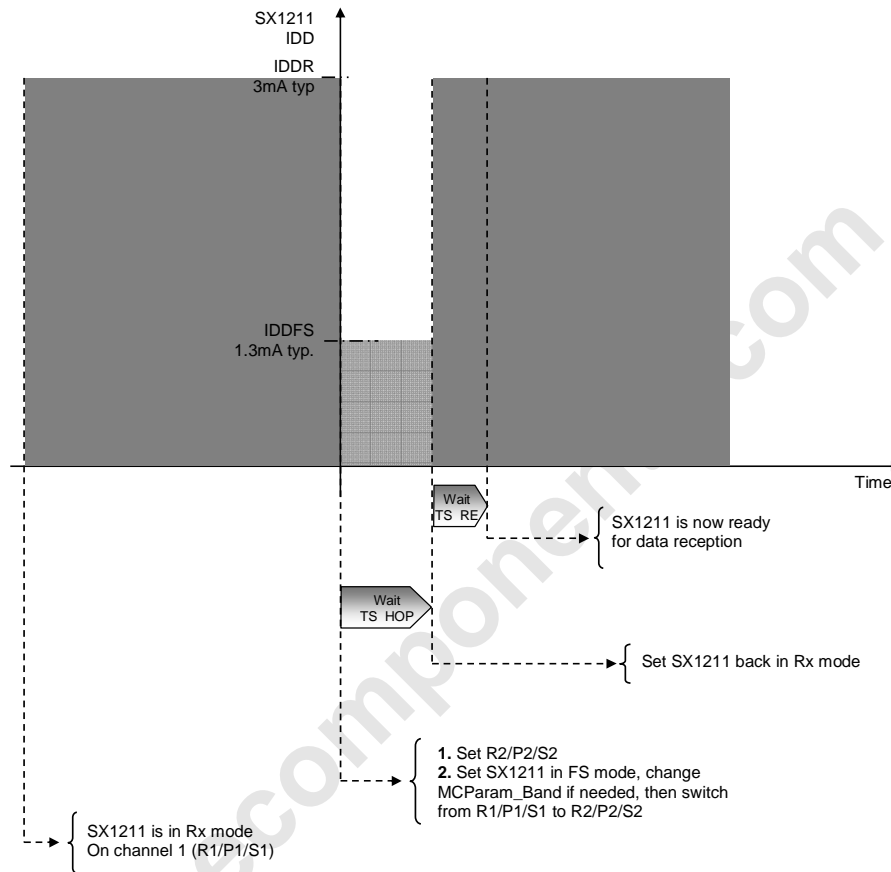

Figure 52: Rx Hop Cycle

Note: it is also possible to move from one channel to the other one without having to switch off the receiver. This method is faster, and overall draws more current. For timing information, please refer to TS\_RE\_HOP on Table 8.

### 7.3.5. Rx→Tx and Tx→Rx Jump Cycles

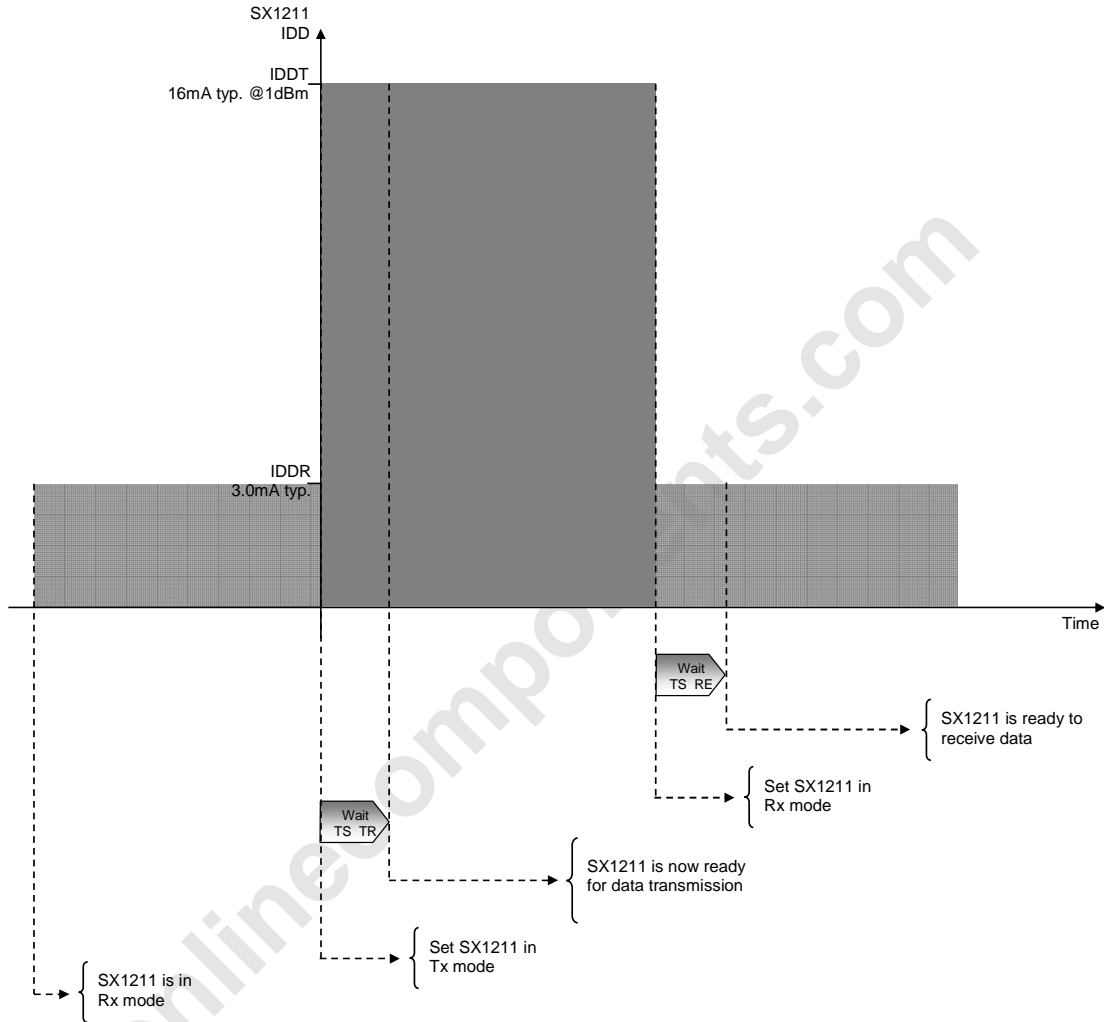

Figure 53: Rx → Tx → Rx Cycle

## 7.4. Reset of the Chip

A power-on reset of the SX1211 is triggered at power up. Additionally, a manual reset can be issued by controlling pin 13.

### 7.4.1. POR

If the application requires the disconnection of VDD from the SX1211, despite of the extremely low Sleep Mode current, the user should wait for 10 ms from of the end of the POR cycle before commencing communications over the SPI bus. Pin 13 (TEST8) should be left floating during the POR sequence.

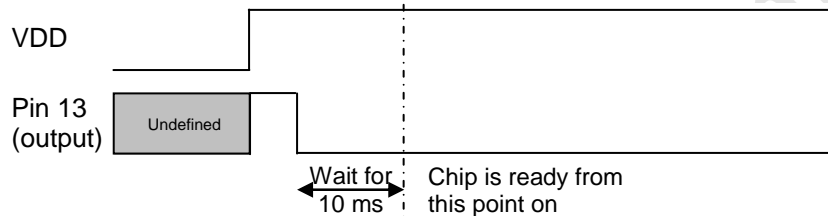

Figure 54: POR Timing Diagram

Please note that any CLKOUT activity can also be used to detect that the chip is ready.

### 7.4.2. Manual Reset

A manual reset of the SX1211 is possible even for applications in which VDD cannot be physically disconnected. Pin 13 should be pulled high for a hundred microseconds, and then released. The user should then wait for 5 ms before using the chip.

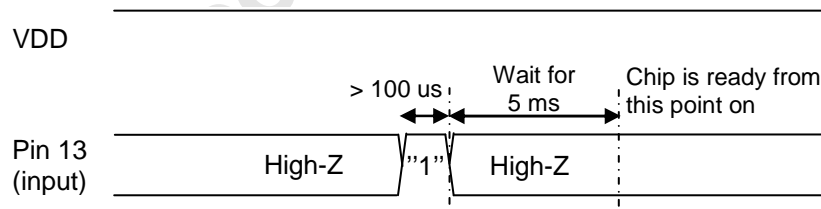

Figure 55: Manual Reset Timing Diagram

Please note that while pin 13 is driven high, an over current consumption of up to ten milliamps can be seen on VDD.

## 7.5. Reference Design

It is recommended that this reference design (i.e. schematics, placement, layout, BOM,) is replicated in the final application board to guarantee optimum performance.

### 7.5.1. Application Schematic

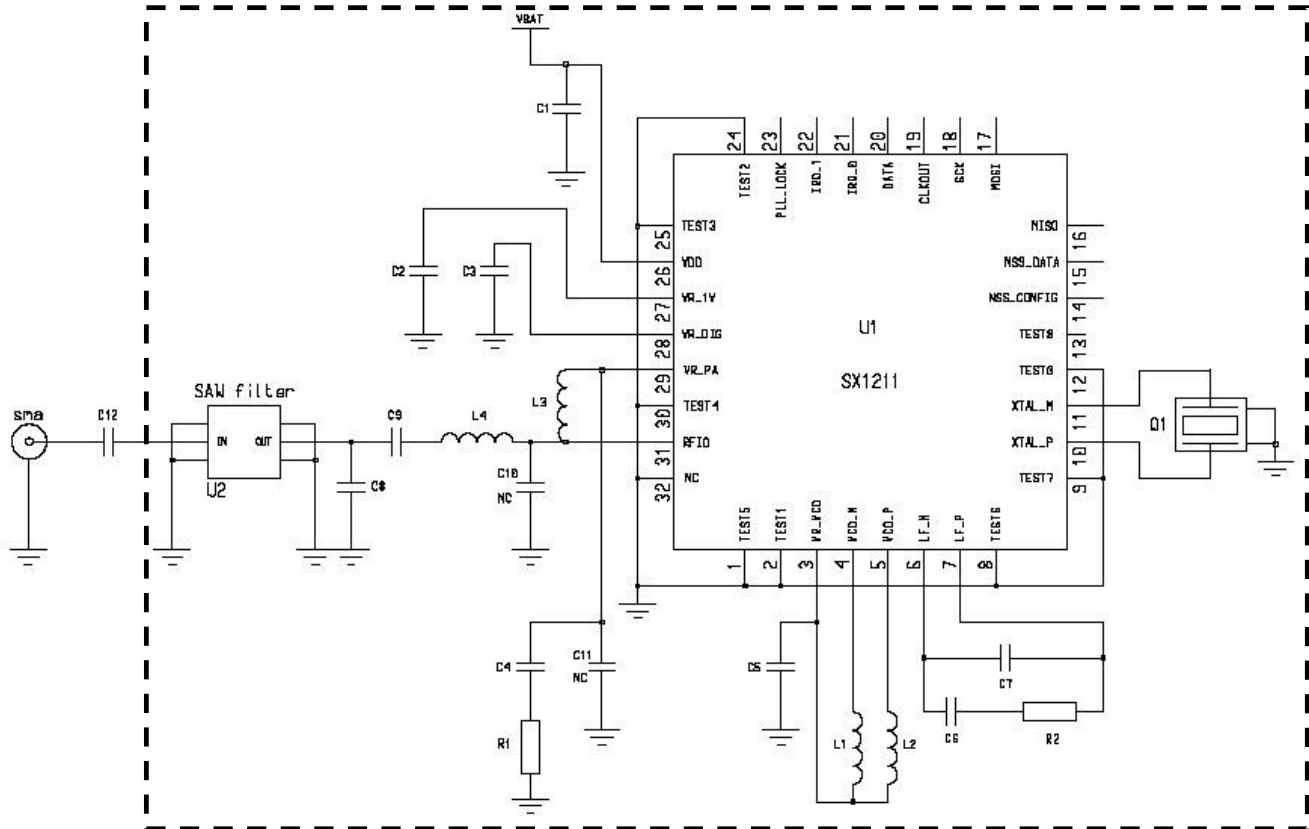

Figure 56: Reference Design Circuit Schematic

The reference design area is represented by the dashed rectangle. C12 is a DC blocking capacitor which protects the SAW filter. It has been added for debug purposes could be removed for a direct antenna connection if there is no DC bias is expected at the antenna port. Please note that C10 and C11 are not used.

### 7.5.2. PCB Layout

As illustrated in figures below, the layout has the following characteristics:

- very compact (9x19mm) => can be easily inserted even on very small PCBs
- standard PCB technology (2 layers, 1.6mm, std via & clearance) => low cost
- Its performance is quasi-insensitive to dielectric thickness => minimal design effort to transfer to other PCB technologies (thickness, # of layers, etc...)

The layers description is illustrated in Figure 57:

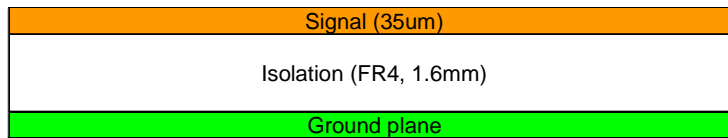

Figure 57: Reference Design's Stackup

The layout itself is illustrated in Figure 58. Please contact Semtech for gerber files.

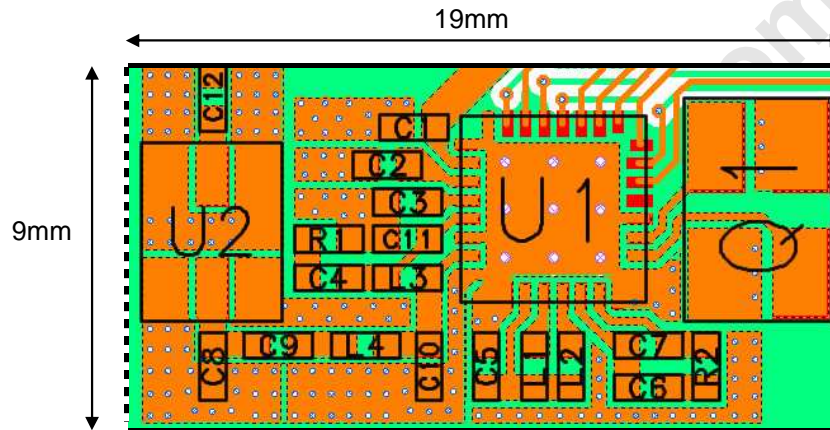

Figure 58: Reference Design Layout (top view)

### 7.5.3. Bill Of Material

Table 35: Reference Design BOM

Ref	Value		Tol (+/-)	Techno	Size	Comment
	868MHz	915MHz				
U1	SX1211		-	Transceiver IC	TQFN-32	-
U2	869 MHz	915 MHz	-	SAW Filter	3.8*3.8 mm	Plotted in section 7.5.4
Q1	12.8 MHz		15 ppm at 25°C 20 ppm over -40/+85°C 2ppm/year max	AT-cut	5.0*3.2 mm	Fundamental, Cload=15 pF
R1	1Ω		1%	-	0402	PA regulator
R2	6.8 kΩ		1%	-	0402	Loop filter
C1	1uF		15%	X5R	0402	VDD decoupling
C2	1uF		15%	X5R	0402	Top regulator decoupling
C3	220 nF		10%	X7R	0402	Digital regulator decoupling
C4	47 nF		10%	X7R	0402	PA regulator decoupling
C5	100 nF		10%	X7R	0402	VCO regulator decoupling
C6	10 nF		10%	X7R	0402	Loop Filter
C7	680 pF		5%	NPO	0402	Loop Filter
C8	1.8 pF		0.25 pF	NPO	0402	Matching
C9	22 pF		5%	NPO	0402	DC block and L4 adjust
L1, L2	8.2 nH	6.8 nH	0.2 nH	Wire wound	0402	VCO tank inductors
L3	100 nH		5%	Wire wound	0402	PA Choke
L4	8.2 nH		5%	Multilayer	0402	Matching
C10, C11	NC		-	-	0402	-
C12*	47pF		5%	NPO	0402	DC block

\*Not part of the ref. design (not required for direct antenna connection).

Note: for battery powered applications, a high value capacitance should be implemented in parallel with C1 (typically 10 μF) to offer a low impedance voltage source during startup sequences.

### 7.5.4. SAW Filter Plot

The following screenshot shows the plot of the SAW filter used on the reference design:

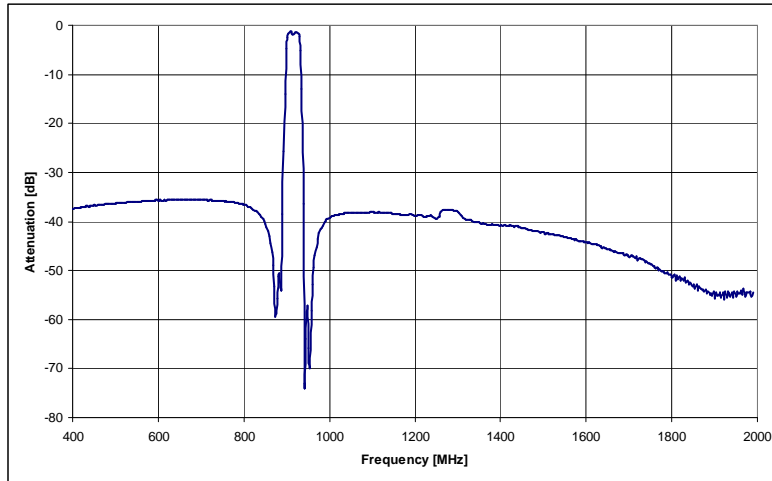

Figure 59: 915 MHz SAW Filter Plot

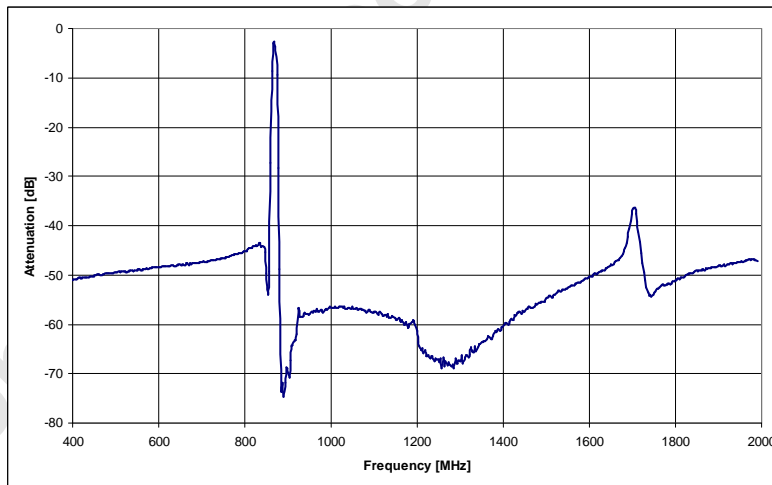

Figure 60: 869 MHz SAW Filter Plot

### 7.5.5. Ordering Information for Tools

The modules described in section 7.5 can be ordered through your Semtech representative for evaluation purpose:

Table 36: Tools Ordering Information

Part Number	Description
SM1211E868	2 layer RF module, 868 MHz band
SM1211E915	2 layer RF module, 915 MHz band
SX1211SK868	Full evaluation kit, including 2 SM1211E868, controller boards, antennas and cables
SX1211SK915	Full evaluation kit, including 2 SM1211E915, controller boards, antennas and cables

## 7.6. Reference Design Performance

All the measurements visible on section 7.6 typical figures obtained under the following conditions, unless otherwise noted:

- Nominal VDD = 3.3 V
- Tests performed at room temperature: 25°C +/-3°C
- Center frequency 869 MHz or 915 MHz
- {R, P, S} triplets are those calculated by the software described in section 3.2.8.
- All register settings are default, except for those stated in the relevant sub-sections
- Maximum Output Power programmed on Pout tests
- All sensitivities are evaluated in Continuous mode, demodulating a PN15 sequence, BER=0.1%
- FSK sensitivities measured at 25kbps, Fdev=+/-50 kHz
- OOK sensitivities measured at 8kbps, with Fo=100 kHz. IF2 set to 100 kHz.
- On all Adjacent Channel Rejection (ACR), Blocking and Spurious Response Frequency tests, the unwanted signal is unmodulated.
- Bill of Materials as shown in section 7.5.3. In particular, a SAW filter is used (see its performance on section 7.5.4)
- The filter settings described on Table 37 and Table 38 were used for the measurements of section 7.6.5.

Table 37: FSK Rx Filters vs. Bit Rate

Bit Rate	Fdev	Filter Setting Addr 16	Fdev + BR/2	Rx 3 dB BW		Max. drift
				Programmed	Actual	
kbps	+/- kHz	Hex	kHz	kHz	kHz	+/- ppm
100	200	FF	250	400	306	62
66.67	133	E9	166.7	250	214	53
50	100	D6	125	175	158	37
40	80	B5	100	150	137	41
33.33	67	A4	83.3	125	116	36
28.57	57	A3	71.4	100	96	27
25	50	A3	62.5	100	96	37
22.22	44	72	55.6	75	69	15
20	40	72	50	75	69	21
18.18	36	72	45.5	75	69	26
16.67	33	72	41.7	75	69	30
15.38	33	41	41	50	47	7
14.29	33	41	40.5	50	47	7
12.5	33	41	39.6	50	47	8
10	33	41	38.3	50	47	10
5	33	41	35.8	50	47	12
2	33	41	34.3	50	47	14

Table 38: OOK Rx Filters vs. Bit Rate

Bit Rate	F <sub>o</sub> + BR	Filter Setting Addr 16	Rx 3 dB BW		Max. drift
			Programmed	Actual	
kbps	kHz	Hex	kHz	kHz	+/- ppm
16.67	117	C1	150	154	41
12.5	113	C1	150	154	46
9.52	110	A0	125	129	22
8	108	A0	125	129	23
4.76	105	A0	125	129	27
2.41	102	A0	125	129	30
1.56	102	A0	125	129	30



### 7.6.1. Sensitivity Flatness

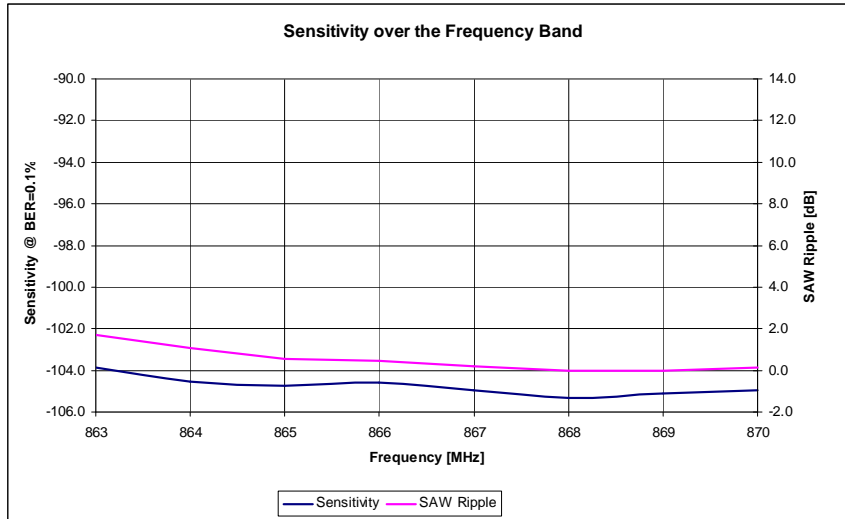

Figure 61: Sensitivity Across the 868 MHz Band

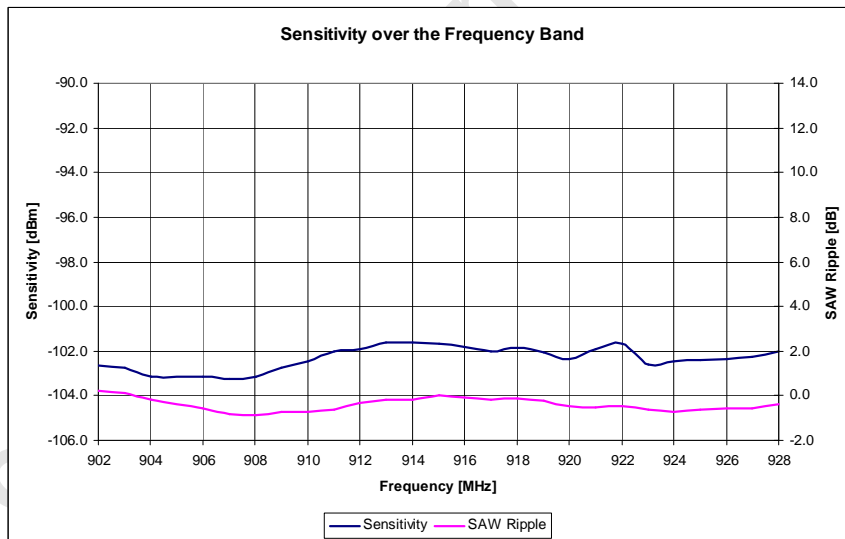

Figure 62: Sensitivity Across the 915 MHz Band

Notes:

- Measured in FSK mode only. OOK sensitivity characteristics will be similar.
- The sensitivity difference along the band remains inside the ripple performance of the SAW filter (the nominal passband of the 869 MHz SAW filter is 868 – 870 MHz)
- The SAW filter ripple response is referenced to its insertion loss at 869 MHz and 915 MHz for each filter.

### 7.6.2. Sensitivity vs. LO Drift

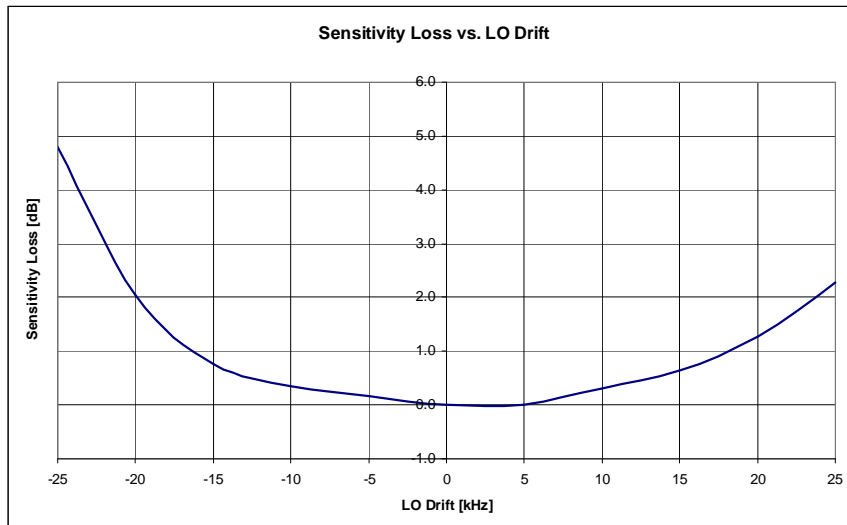

Figure 63: FSK Sensitivity Loss vs. LO Drift

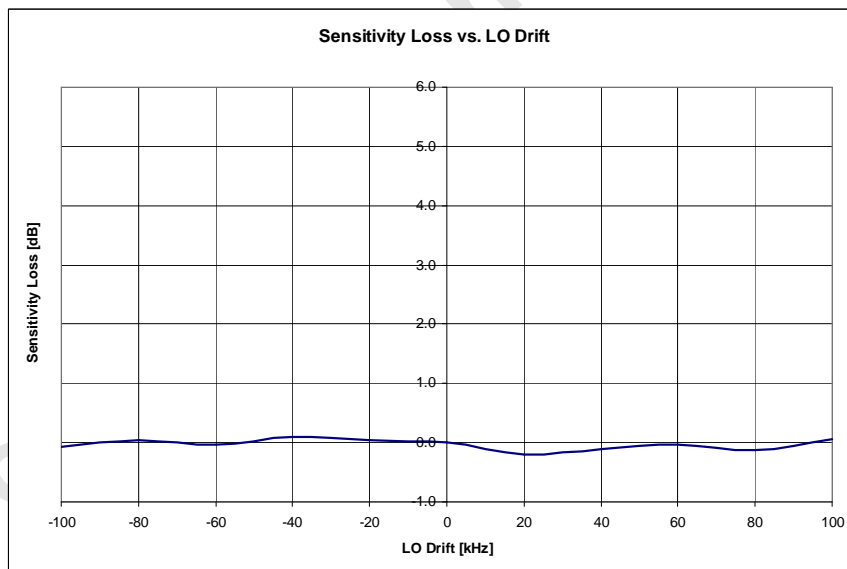

Figure 64: OOK Sensitivity Loss vs. LO Drift

Notes:

- In FSK Mode, the default filter setting (“A3” at address \$16) is kept, leading to  $F_c=96$  kHz typ.
- In OOK Mode, “F3” is set at address \$16, leading to  $(F_c-F_o)=95$  kHz typ.
- The above ensures that the channel filter is wide enough, therefore characterizing the demodulator response, and NOT the filter response.

7.6.3. Sensitivity vs. Receiver BW

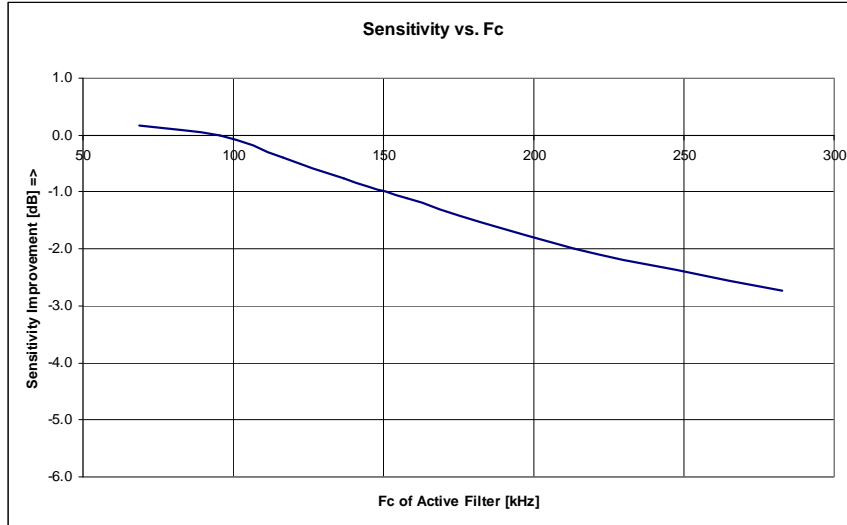

Figure 65: FSK Sensitivity vs. Rx BW

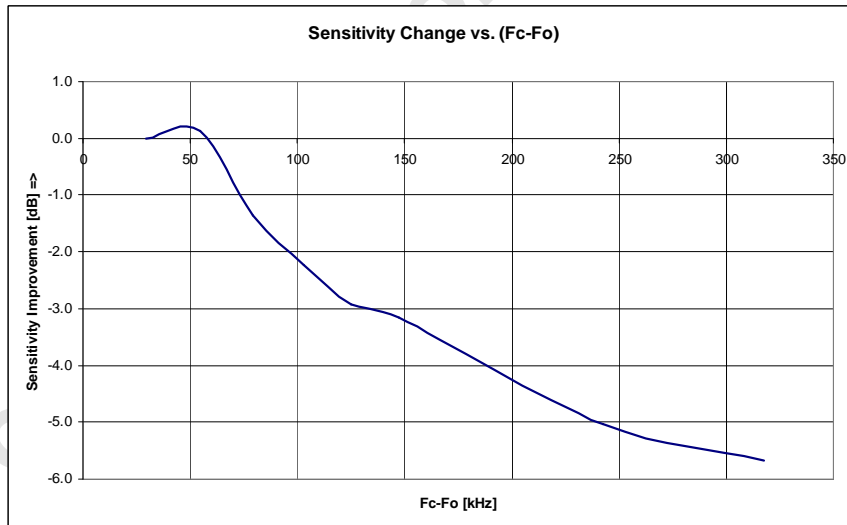

Figure 66: OOK Sensitivity Change vs. Rx BW

### 7.6.4. Sensitivity Stability over Temperature and Voltage

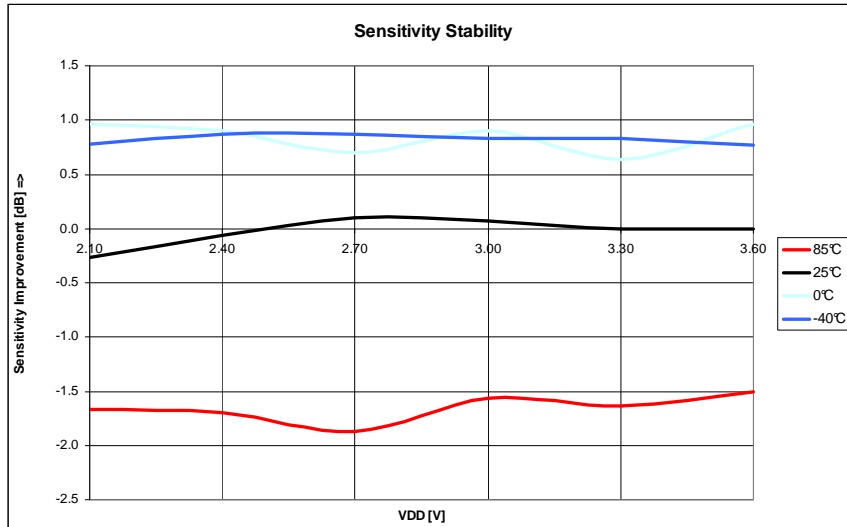

Figure 67: Sensitivity Stability

Note:

- The sensitivity performance is very stable over the VDD range, and the effect of high temperature is minimal.

### 7.6.5. Sensitivity vs. Bit Rate

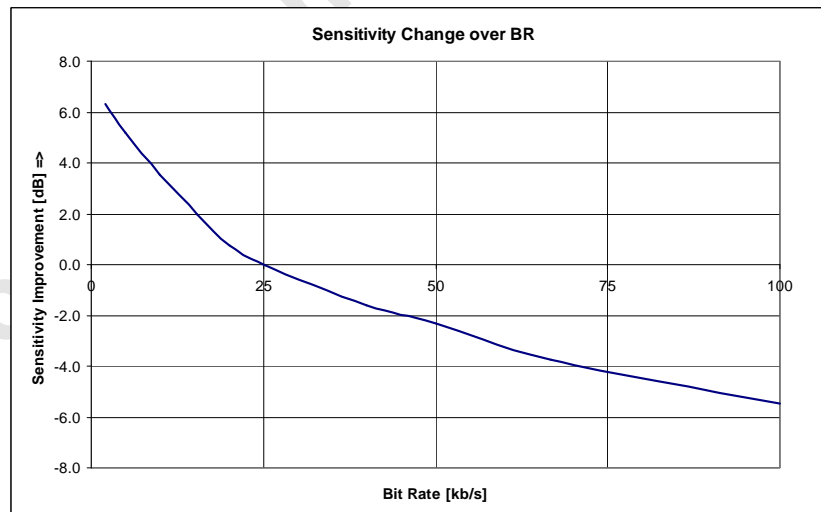

Figure 68: FSK Sensitivity vs. BR

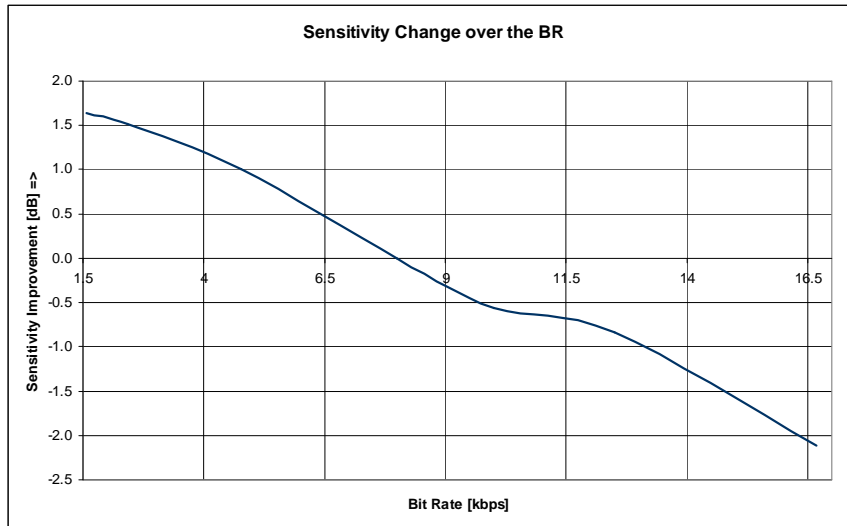

Figure 69: OOK Sensitivity vs. BR

### 7.6.6. Adjacent Channel Rejection

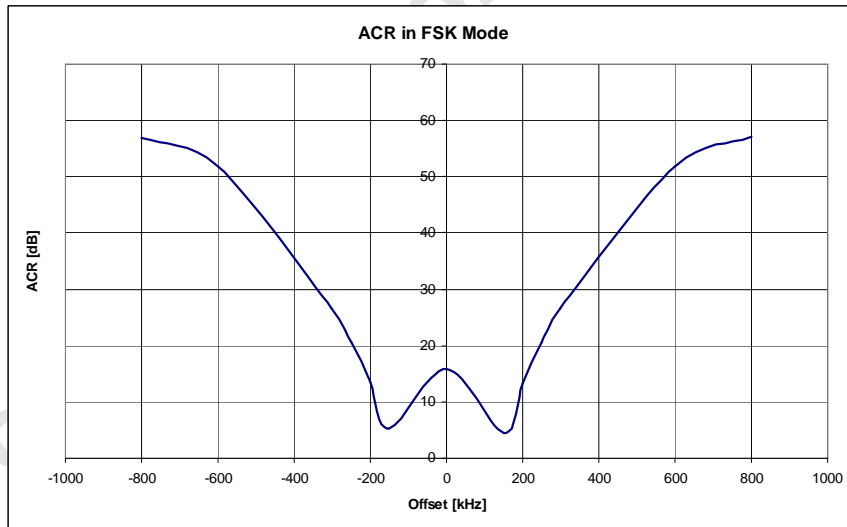

Figure 70: ACR in FSK Mode

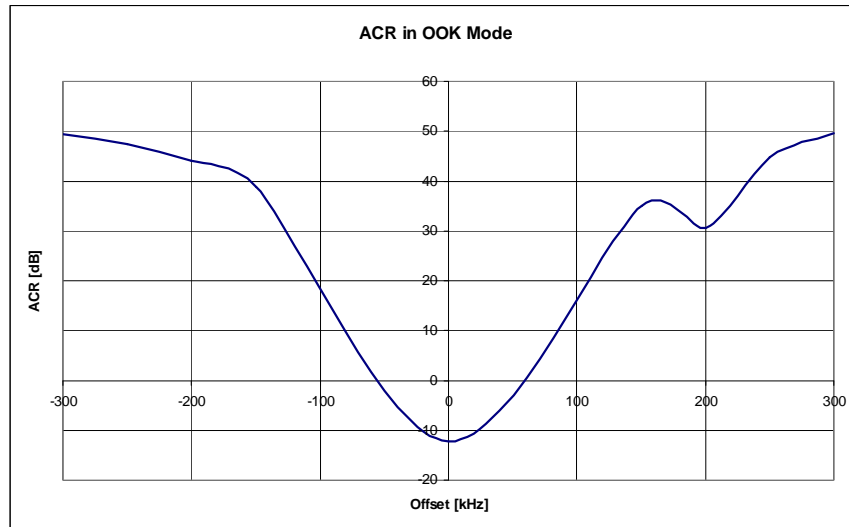

Figure 71: ACR in OOK Mode

Notes:

- In FSK mode, the unwanted signal is unmodulated (as described in the EN 300-220 V2.1.1). Co-Channel Rejection (CCR, Offset = 0kHz) is positive due to the DC cancellation process of the zero-IF architecture
- In OOK mode, the polyphase filter efficiency is limited, thus limiting the adjacent channel rejection at 2x $F_o$  distance.

**7.6.7. Output Power Flatness**

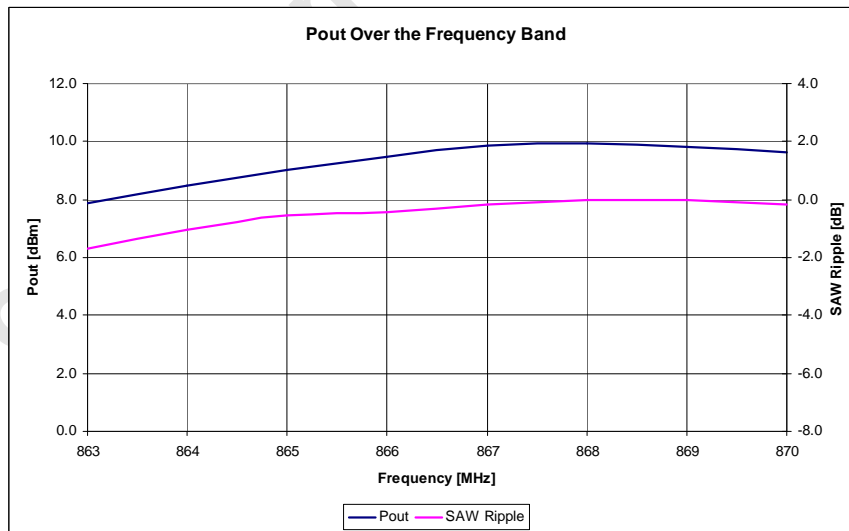

Figure 72: Pout for 869 MHz Band Operation

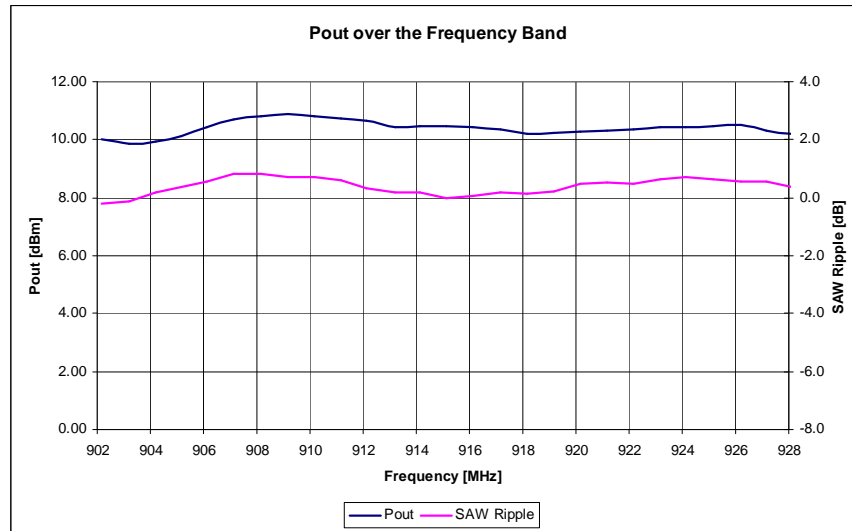

Figure 73: Pout for 915 MHz Band Operation

Notes:

- As noted in section 7.5.4, the 869 MHz SAW filter does not cover the whole European 863 – 870 MHz frequency band when used in a 50 ohms environment. Hence the output power degradation at the lowest frequencies. For applications in the 863 – 870 MHz band it is recommended that an appropriate SAW filter be implemented or that the SAW response tuned by external matching.
- The SAW filter ripple references are the insertion loss of each SAW at 869 MHz and 915 MHz.

**7.6.8. Pout and IDD vs. PA Setting**

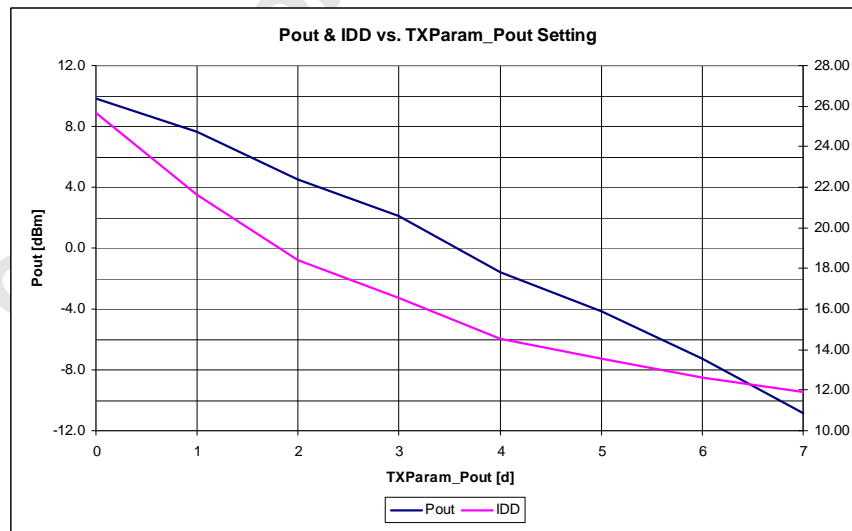

Figure 74: Pout and IDD at all PA Settings, 869 MHz

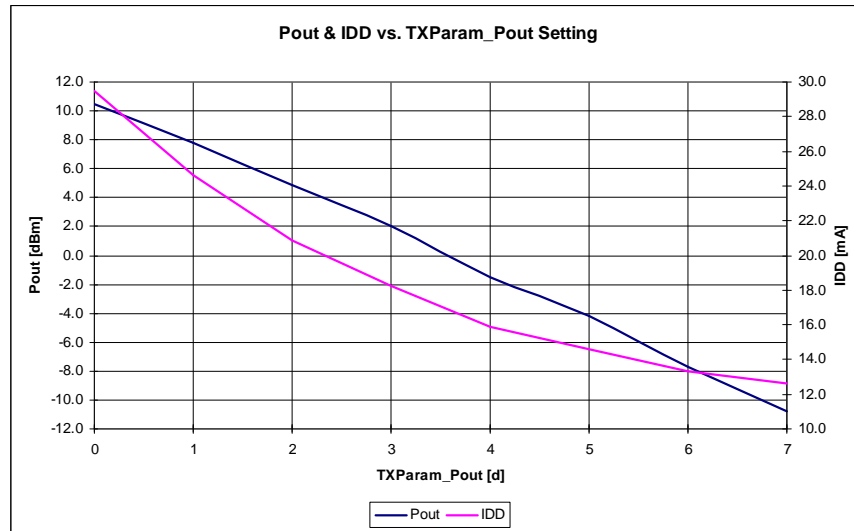

Figure 75: Pout and IDD at all PA Settings, 915 MHz

Note:

- +10dBm typ. Output power is achievable, even at SAW filter's output.

### 7.6.9. Pout Stability over Temperature and Voltage

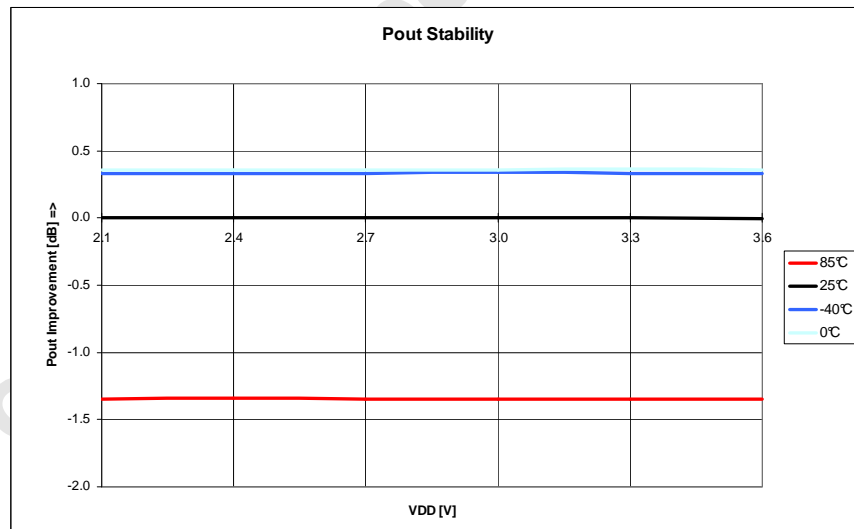

Figure 76: Pout Stability

The output power is not sensitive to the supply voltage, and it decreases slightly when temperature rises.



**7.6.10. Transmitter Spectral Purity**

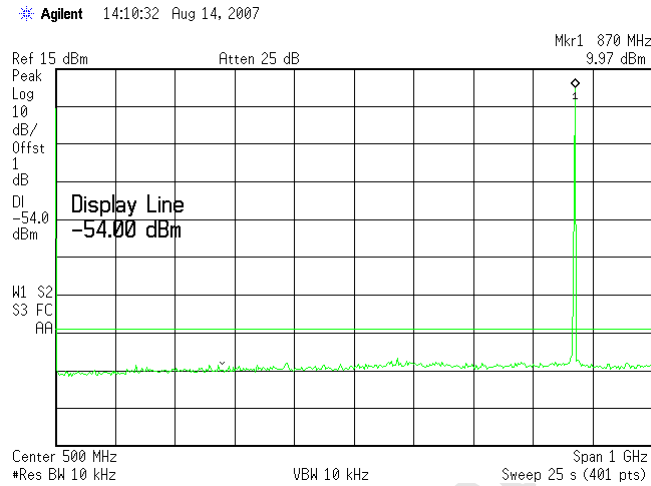

Figure 77: 869 MHz Spectral Purity DC-1GHz

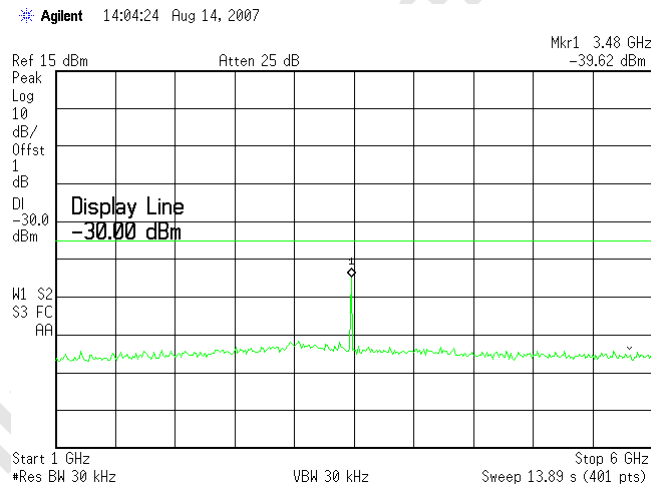

Figure 78: 869 MHz Spectral Purity 1-6GHz

### 7.6.11. OOK Channel Bandwidth

The OOK bit rate ranges from 1.56 to 16.7 kbps. It is interesting to note that, for the lowest bit rates, a channel spacing approaching 200 kHz is achievable:

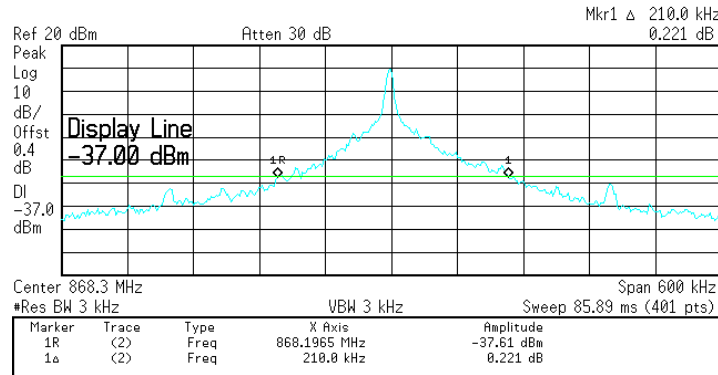

Figure 79: OOK Spectrum - 2kbps

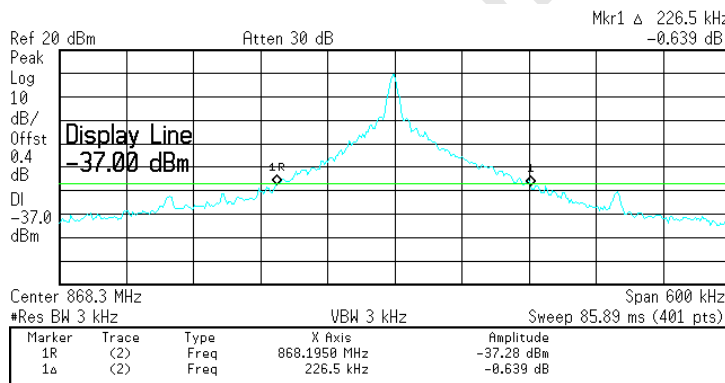

Figure 80: OOK Spectrum - 8kbps

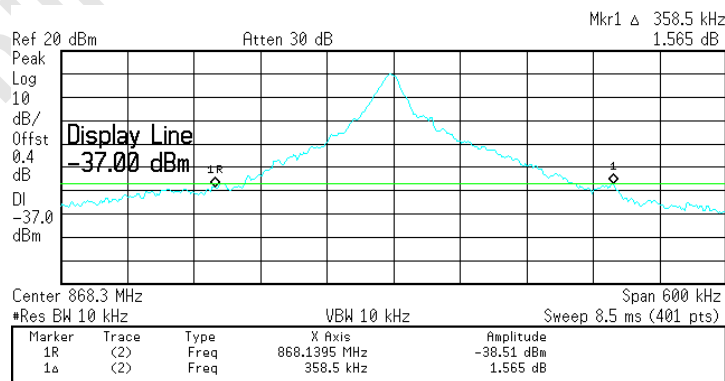

Figure 81: OOK Spectrum - 16.7kbps

Notes:

- The test conditions are: Fdev=100 kHz, TXParam\_InterpFilt = 200 kHz

### 7.6.12. FSK Spectrum in Europe

Figure 82 shows the minimal spectral occupation achievable in the European band, keeping in mind that the minimum frequency deviation that a SX1211 receiver can accept is 33 kHz. If the companion receiver can bear smaller frequency deviations, the range of modulation bandwidth can be further decreased.

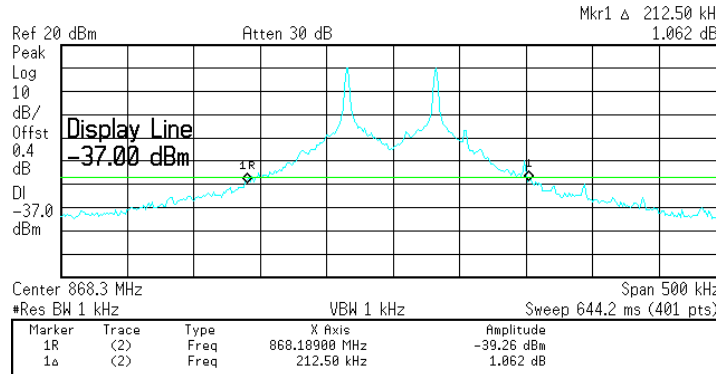

Figure 82: FSK - 1.56kbps - +/-33 kHz

The default configuration of the SX1211 yields the bandwidth visible on Figure 83:

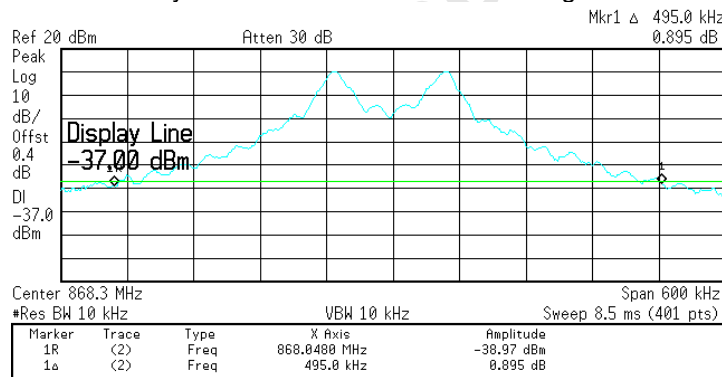

Figure 83: FSK - 25 kbps - +/-50 kHz

Figure 84 shows the maximal bit rate and frequency deviation that can fit in the 868 to 868.6 MHz European sub-band:

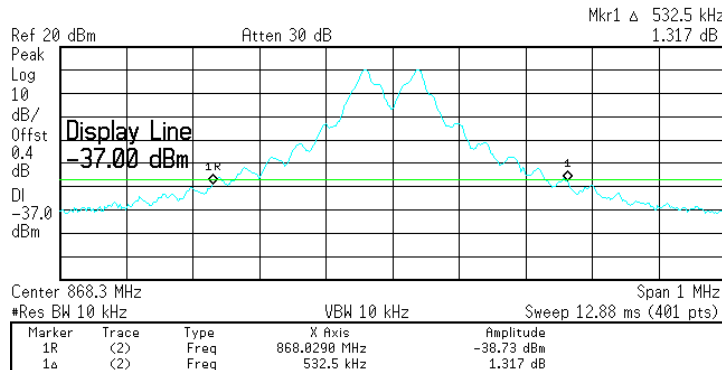

Figure 84: FSK - 40 kbps - +/-40 kHz

### 7.6.13. Digital Modulation Schemes

FCC Part 15.247 allows for systems employing digital modulation techniques to transmit up to 1 W, provided that the 6 dB bandwidth of the signal is at least 500 kHz and that the power spectral density does not exceed 8dBm in any 3 kHz bandwidth.

The SX1211 can actually meet these constraints whilst transmitting at the maximum output power of the device of typ. 10dBm, thanks to the built-in whitening process described in section 5.5.6.2:

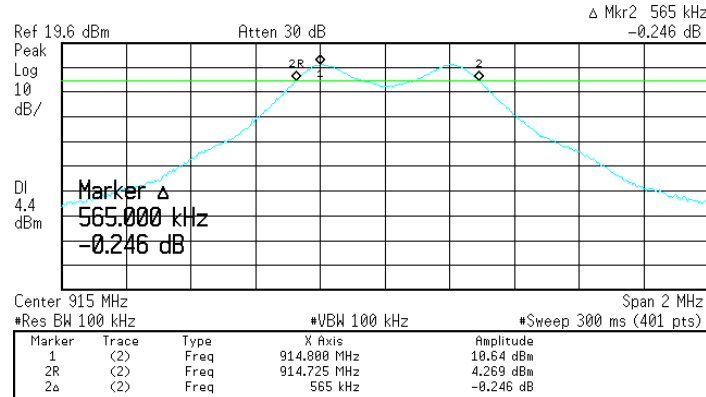

Figure 85: DTS 6dB Bandwidth

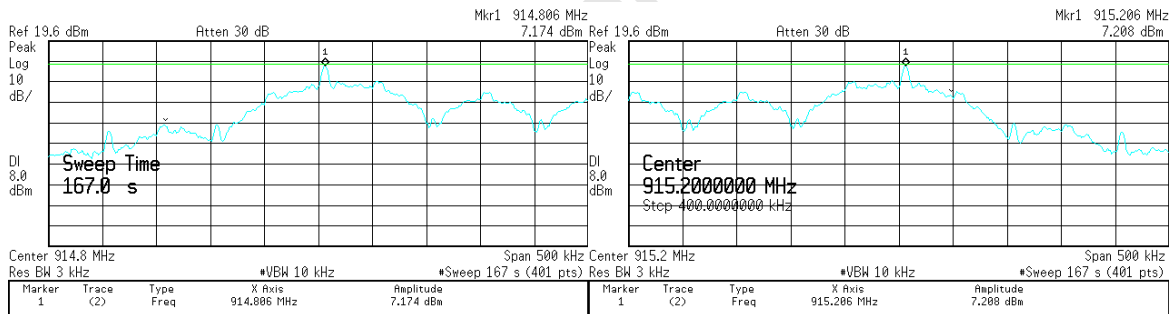

Figure 86: DTS Power Spectral Density

Conditions:

- Pout = +10.6dBm
- Fdev = +/-200kHz
- BR=100 kbps (Chip rate=100kCps, as data whitening is enabled)
- Packet mode, data whitening enabled

Note: Manchester encoding allows meeting an even lower power spectral density, at the expense of the bit rate efficiency.

7.6.14. Current Stability over Temperature and Voltage

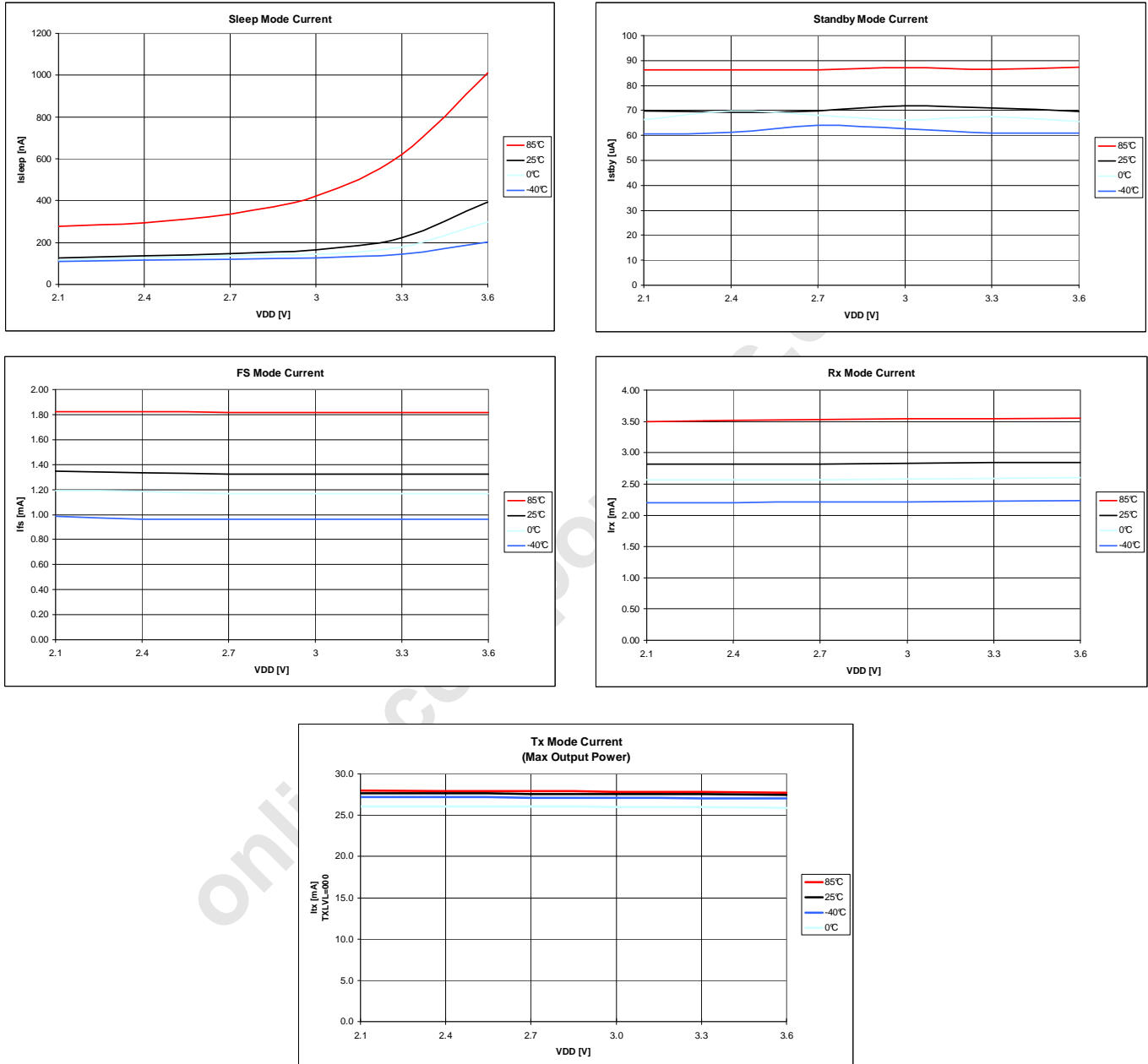

Figure 87: IDD vs. Temp and VDD

## 8. Packaging Information

### 8.1. Package Outline Drawing

SX1211 is available in a 32-lead TQFN package as shown in Figure 88 below.

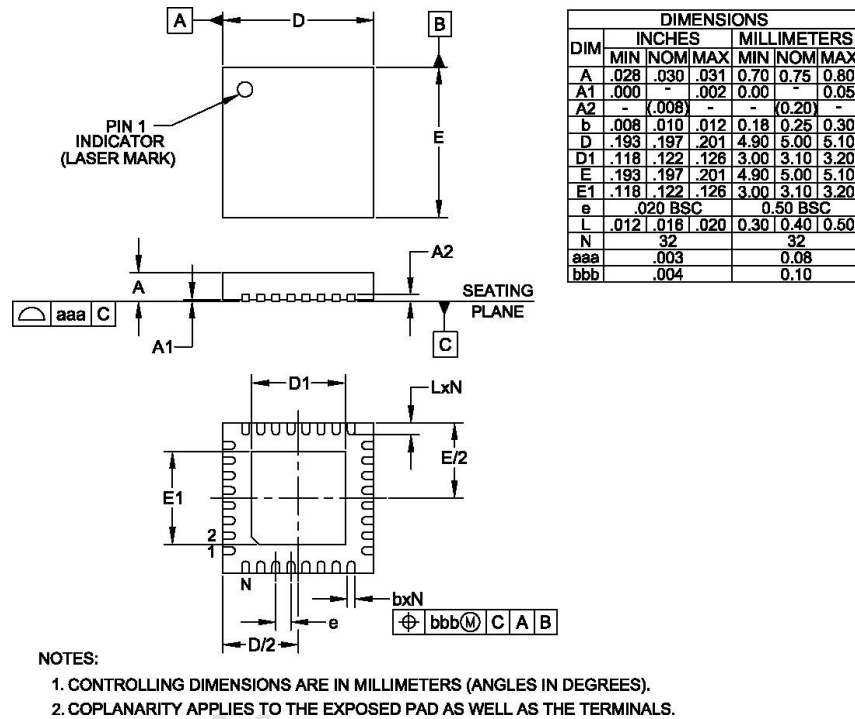
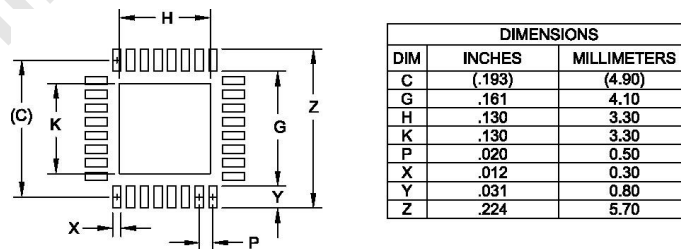

Figure 88: Package Outline Drawing

### 8.2. PCB Land Pattern



- NOTES:
1. CONTROLLING DIMENSIONS ARE IN MILLIMETERS (ANGLES IN DEGREES).
  2. THIS LAND PATTERN IS FOR REFERENCE PURPOSES ONLY. CONSULT YOUR MANUFACTURING GROUP TO ENSURE YOUR COMPANY'S MANUFACTURING GUIDELINES ARE MET.
  3. THERMAL VIAS IN THE LAND PATTERN OF THE EXPOSED PAD SHALL BE CONNECTED TO A SYSTEM GROUND PLANE. FAILURE TO DO SO MAY COMPROMISE THE THERMAL AND/OR FUNCTIONAL PERFORMANCE OF THE DEVICE.

Figure 89: PCB Land Pattern

### 8.3. Tape & Reel Specification

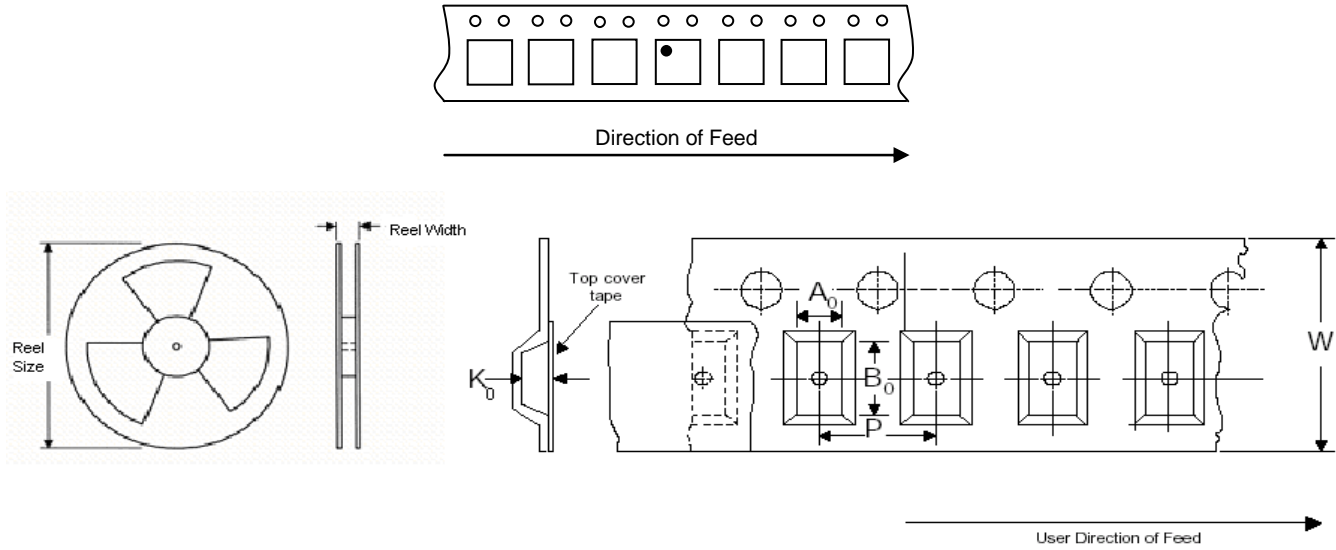

Carrier Tape				Reel				
Tape Width(W)	Pocket Pitch (P)	Ao/Bo	Ko	Reel Size	Reel Width	Min.Trailer Length	Min. Leader Length	QTY per Reel
12 +/-0.3	8 +/-0.1	5.25 +/-0.2	1.10 +/-0.1	330.2	12.4	400	400	3000

Notes:  
\*all dimensions in mm  
\*single sprocket holes

Figure 90: Tape & Reel Dimensions

## 9. Revision History

### Revision 5

- Increase maximum Bit Rate in FSK
- Update minimum XO frequency
- Add the manual reset description
- Insert decoupling recommendation for battery operated systems
- Add Tools ordering information

### Revision 6

- Update SPI speed
- Clarify default fc value in Table 29
- Clarify MISO state in SPI timing figures
- Improve ESD rating description

### Revision 7

- Describe PLL\_LOCK pin state in Table 13
- Improve note in section 5.4.1
- Clarify Table 5 measurement conditions
- Clarify /Fifoempty interrupt source behavior
- Correct Vtune in Figure 5
- Adjust VCO tuning range in section 3.2.5.2

## 10. Contact Information

Semtech Corporation  
Advanced Communication and Sensing Products Division  
200 Flynn Road, Camarillo, CA 93012  
Phone (805) 498-2111 Fax: (805) 498-3804

© Semtech 2008

All rights reserved. Reproduction in whole or in part is prohibited without the prior written consent of the copyright owner. The information presented in this document does not form part of any quotation or contract, is believed to be accurate and reliable and may be changed without notice. No liability will be accepted by the publisher for any consequence of its use. Publication thereof does not convey nor imply any license under patent or other industrial or intellectual property rights. Semtech. assumes no responsibility or liability whatsoever for any failure or unexpected operation resulting from misuse, neglect improper installation, repair or improper handling or unusual physical or electrical stress including, but not limited to, exposure to parameters beyond the specified maximum ratings or operation outside the specified range.

SEMTECH PRODUCTS ARE NOT DESIGNED, INTENDED, AUTHORIZED OR WARRANTED TO BE SUITABLE FOR USE IN LIFE-SUPPORT APPLICATIONS, DEVICES OR SYSTEMS OR OTHER CRITICAL APPLICATIONS. INCLUSION OF SEMTECH PRODUCTS IN SUCH APPLICATIONS IS UNDERSTOOD TO BE UNDERTAKEN SOLELY AT THE CUSTOMER'S OWN RISK. Should a customer purchase or use Semtech products for any such unauthorized application, the customer shall indemnify and hold Semtech and its officers, employees, subsidiaries, affiliates, and distributors harmless against all claims, costs damages and attorney fees which could arise.