

**16-Bit BiDirectional Transceiver
with 3-State Outputs**
Features

- PI74ALVTC family is designed for low voltage operation, $V_{DD} = 1.8V$ to $3.6V$
- Supports Live Insertion
- 3.6V I/O Tolerant Inputs and Outputs
- Bus Hold
- High Drive, $-32/64mA$ @ $3.3V$
- Uses patented noise reduction circuitry
- Power-off high impedance inputs and outputs
- Industrial operation at $-40^{\circ}C$ to $+85^{\circ}C$
- Packaging (Pb-free & Green available):
 - 48-pin 240-mil wide plastic TSSOP (A)
 - 48-pin 173-mil wide plastic TVSOP (K)
 - 48-pin 300-mil wide plastic SSOP (V)

Description

Pericom Semiconductor's PI74ALVTC16245 is a 16-bit bidirectional transceiver designed for asynchronous two-way communication between data buses. The direction control input pin (xDIR) determines the direction of data flow through the bidirectional transceiver. The Direction and Output Enable controls are designed to operate this device as either two independent 8-bit transceivers or one 16-bit transceiver. The output enable (\overline{OE}) input, when HIGH, disables both A and B ports by placing them in Hi-Z condition.

To ensure the high-impedance state during power up or power down, OE should be tied to V_{DD} through a pullup resistor; the minimum value of the resistor is determined by the current-sinking capability of the driver.

The family offers both I/O Tolerant, which allows it to operate in mixed 1.8/3.6V systems, and "Bus Hold," which retains the data input's last state whenever the data input goes to high-impedance, preventing "floating" inputs and eliminating the need for pullup/down resistors.

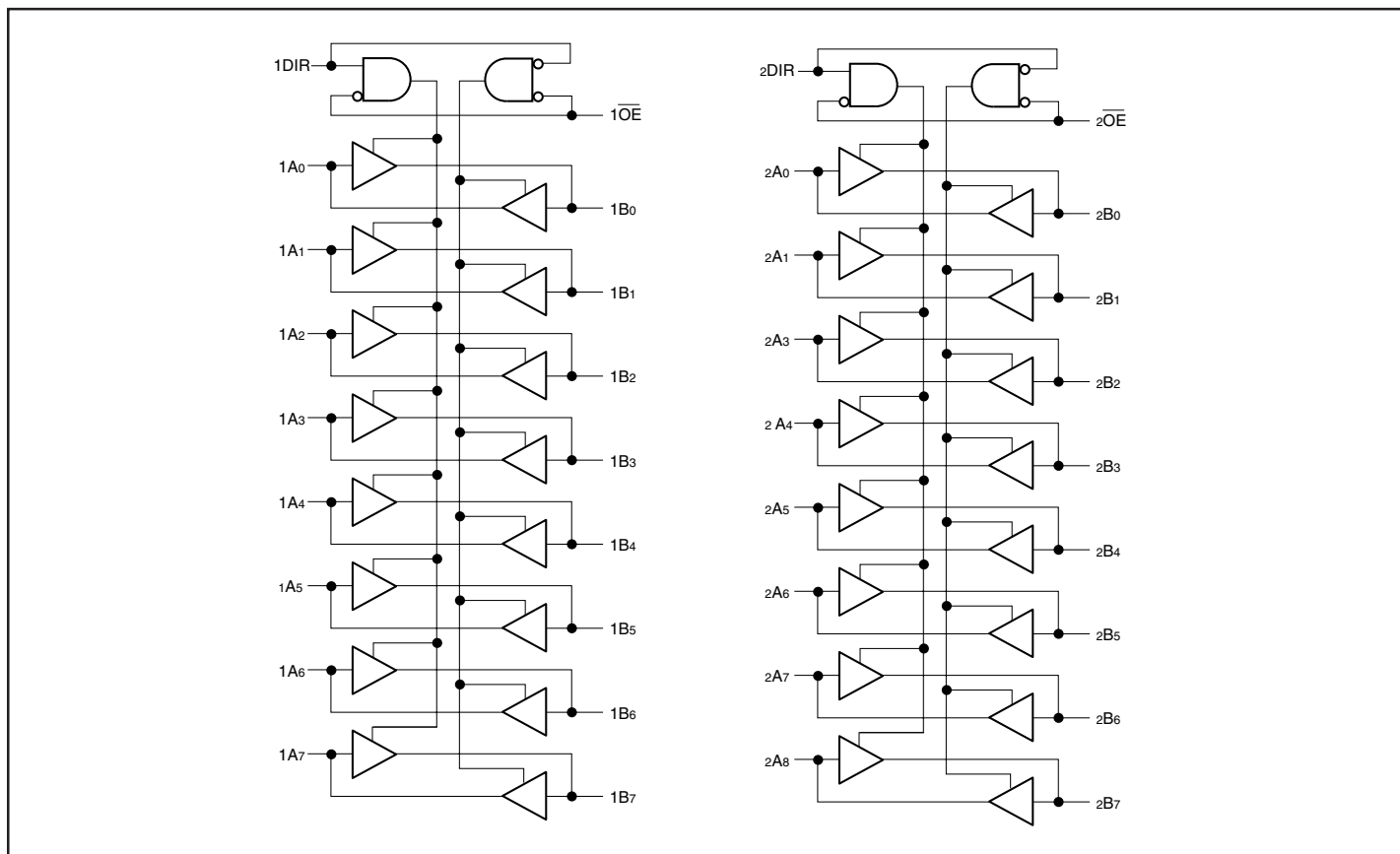
Block Diagram

Product Pin Description

Pin Name	Description
\overline{xOE}	3-State Output Enable Inputs (Active LOW)
xDIR	Direction Control Input
xAx	Side A Inputs or 3-State Inputs
xBx	Side B Inputs or 3-State Outputs
GND	Ground
Vcc	Power

Truth Table⁽¹⁾

Inputs		Outputs
\overline{xOE}	xDIR	
L	L	Bus B Data to Bus A
L	H	Bus A Data to Bus B
H	X	High Z State

Notes:

- H = High Signal Level
L = Low Signal Level
X = Don't Care or Irrelevant
Z = High Impedance

Product Pin Configuration

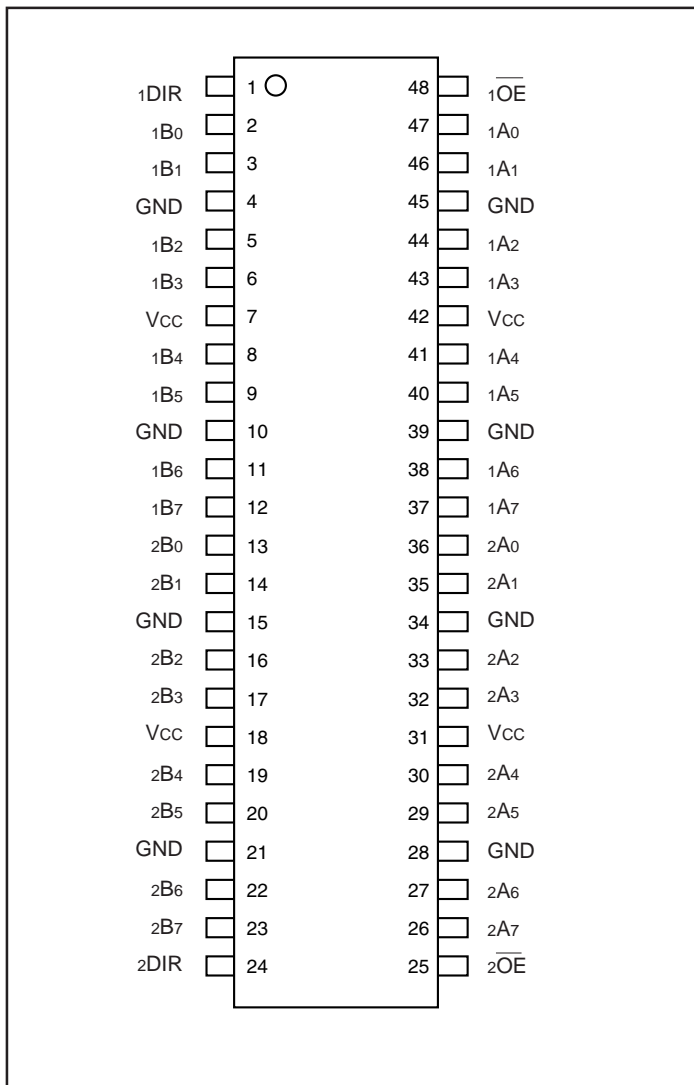

Maximum Ratings

(Above which the useful life may be impaired. For user guidelines, not tested.)

Supply Voltage Range, V_{DD}	-0.5V to 4.6V
Input Voltage Range, V_I	-0.5V to 4.6V
Output Voltage Range, V_O (3-States)	-0.5V to 4.6V
Output Voltage Range, $V_O^{(1)}$ (Active)	-0.5V to $V_{DD} + 0.5V$
DC Input Diode Current (I_{IK}) $V_I < 0V$	-50mA
DC Output Diode Current (I_{OK})	
$V_O < 0V$	-50mA
$V_O > V_{DD}$	+50mA
DC Output Source/Sink Current (I_{OH}/I_{OL})	-64/128mA
DC V_{DD} or GND Current per Supply Pin (I_{CC} or GND)	$\pm 100mA$
Storage Temperature Range, T_{stg}	-65°C to 150°C

Note:

Stresses greater than those listed under MAXIMUM RATINGS may cause permanent damage to the device. This is a stress rating only and functional operation of the device at these or any other conditions above those indicated in the operational sections of this specification is not implied. Exposure to absolute maximum rating conditions for extended periods may affect reliability.

Notes:

1. Absolute maximum of I_O must be observed.

Recommended Operating Conditions⁽¹⁾

			Min.	Max.	Units
V_{DD}	Supply voltage	Operating	1.8	3.6	V
		Data Retention Only	1.2	3.6	
V_{IH}	High-level input voltage	$V_{DD} = 2.7V$ to $3.6V$	2.0		
V_{IL}	Low-level input voltage	$V_{DD} = 2.7V$ to $3.6V$		0.8	
V_I	Input voltage		-0.3	3.6	
V_O	Output voltage	Active State	0	V_{DD}	
		Off State	0	3.6	
I_O	Output current in I_{OH}/I_{OL}	$V_{DD} = 3.0V$ to $3.6V$ $V_{DD} = 2.7V$ to $3.0V$ $V_{DD} = 2.3V$ to $2.7V$ $V_{DD} = 1.8V$		-32/64 ± 24 ± 18 ± 6	mA
$\Delta t/\Delta v$	Input transition rise or fall rate ⁽²⁾		0	10	ns/V
T_A	Operating free-air temperature		-40	85	C

Notes:

1. Unused control inputs must be held HIGH or LOW to prevent them from floating.
2. As measured between 0.8V and 2.0V, $V_{DD} = 3.0V$.

Electrical Characteristics over Recommended Operating Free-Air Temperature Range

(unless otherwise noted)

DC Characteristics (2.7V V_{DD} ≤ 3.6V)

	Parameter	Conditions	V_{DD}	Min.	Typ.	Max.	Units
V_{IH}	HIGH Level Input Voltage		2.7 - 3.6	2.0			V
V_{IL}	LOW Level Input Voltage					0.8	
V_{OH}	HIGH Level Output Voltage	$I_{OH} = -100\mu A$			$V_{DD} - 0.2$		
		$I_{OH} = -12mA$	2.7	2.2			
		$I_{OH} = -18mA$	3.0	2.4			
		$I_{OH} = -24mA$		2.2			
		$I_{OH} = -32mA$		2.0			
V_{OL}	LOW Level Output Voltage	$I_{OL} = 100\mu A$	2.7 - 3.6			0.2	
		$I_{OL} = 12mA$	2.7			0.4	
		$I_{OL} = 18mA$	3.0			0.4	
		$I_{OL} = 24mA$				0.45	
		$I_{OL} = 32mA$				0.5	
		$I_{OL} = 64mA$				0.55	
I_I	Input Leakage Current	$V_I = V_{DD}$, or GND	3.6			±5.0	μA
I_{OZ}	3-STATE Output Leakage	$V_O = 3.6V$	2.7			±10	
I_{OFF}	Power-OFF Leakage Current	V_I or $V_O \leq 3.6V$	0			10	
I_{ODL}	Output Current Low	$V_{IN} = V_{IH}$ or V_{IL} , $V_O = 1.5V^{(1)}$	3.6	150		334	mA
I_{ODH}	Output Current High	$V_{IN} = V_{IH}$ or V_{IL} , $V_O = 1.5V^{(1)}$		-58		-114	
I_{HOLD}	Bus Hold Current A or B Outputs	$V_I = 0.8V$	3.0	75			μA
		$V_I = 2.0V$		-75			
		$V_I = 0$ to 3.6V	3.6			±500	
I_{DD}	Quiescent Supply Current	$V_I = V_{DD}$ or GND	2.7 - 3.6			50	μA
		$V_{DD} \leq (V_I, V_O) \leq 3.6V$				±50	
ΔI_{DD}	Increase in I_{DD} per input	$V_{IH} = V_{DD} - 0.6V$, Other inputs at V_{DD} or GND					

Notes:

1. Duration of test must not exceed 1 second with only 1 output tested at a time.

Electrical Characteristics over Recommended Operating Free-Air Temperature Range

(unless otherwise noted)

DC Characteristics (2.3V ≤ V_{DD} ≤ 2.7V)

Description	Parameters	Conditions	V _{DD}	Min.	Typ.	Max.	Units
V _{IH}	HIGH Level Input Voltage		2.3 - 2.7	1.6			V
V _{IL}	LOW Level Input Voltage					0.7	
V _{OH}	HIGH Level Output Voltage	I _{OH} = -100μA	2.3	V _{DD} - 0.2			
		I _{OH} = -12mA		1.8			
		I _{OH} = -18mA		1.7			
V _{OL}	LOW Level Output Voltage	I _{OL} = 100μA	2.3 - 2.7			0.2	
		I _{OL} = 12mA	2.3			0.4	
		I _{OL} = 18mA				0.5	
		I _{OL} = 24mA				0.55	
I _I	Input Leakage Current	V _I = V _{DD} or GND	2.7			±5.0	
I _{OZ}	3-STATE Output Leakage	V _O = 3.6V	2.3			±10	
I _{OFF}	Power-OFF Leakage Current	V _I or V _O ≤ 3.6V	0			10	
I _{ODL}	Output Current Low	V _{IN} = V _{IH} or V _{IL} , V _O = 1.5V ⁽²⁾	2.7	110		264	mA
I _{ODH}	Output Current High	V _{IN} = V _{IH} or V _{IL} , V _O = 1.5V ⁽²⁾		-30		-60	
I _{HOLD} ⁽¹⁾	Bus Hold Current A or B Outputs	V _I = 0.7V	2.5		90		μA
		V _I = 1.7V			-90		
I _{DD}	Quiescent Supply Current	V _I = V _{DD} or GND	2.3 - 2.7			40	μA
		V _{DD} ≤ (V _I , V _O) ≤ 3.6V				±40	
ΔI _{DD}	Increase in I _{DD} per input	V _{IH} = V _{DD} - 0.6V, Inputs at V _{DD} or GND					

Notes:

1. Not guaranteed.
2. Duration of test must not exceed 1 second with only 1 output tested at a time.

Electrical Characteristics over Recommended Operating Free-Air Temperature Range

(unless otherwise noted)

DC Characteristics (1.8V ≤ V_{DD} ≤ 2.3V)

Description	Parameters	Conditions	V _{DD}	Min.	Typ.	Max.	Units	
V _{IH}	HIGH Level Input Voltage		1.8 - 2.3	0.7 x V _{DD}			V	
V _{IL}	LOW Level Input Voltage					0.2 x V _{DD}		
V _{OH}	HIGH Level Output Voltage	I _{OH} = -100μA	1.8	V _{DD} - 0.2				
		I _{OH} = -6mA		1.4				
V _{OL}	LOW Level Output Voltage	I _{OL} = 100μA						0.2
		I _{OL} = 6mA						0.3
I _I	Input Leakage Current	V _I = V _{DD} or GND	2.3			±5.0	μA	
I _{OZ}	3-State Output Leakage	V _O = 3.6V	1.8			±10		
I _{OFF}	Power-OFF Leakage Current	V _I = V _O ≤ 3.6V	0			10		
I _{ODL}	Output Current Low	V _{IN} = V _{IH} or V _{IL} , V _O = 0.9V ⁽²⁾	1.8	50		137	mA	
I _{ODH}	Output Current High	V _{IN} = V _{IH} or V _{IL} , V _O = 0.9V ⁽²⁾			-14			-34
I _{HOLD} ⁽¹⁾	Bus Hold Current A or B Outputs	V _I = 0.4	1.8		50		μA	
		V _I = 1.3			-50			
I _{DD}	Quiescent Supply Current	V _I = V _{DD} or GND						20
		V _{DD} ≤ (V _I , V _O) ≤ 3.6V						±20
ΔI _{DD}	Increase in I _{DD} per input	V _I = V _{DD} - 0.6V, Other inputs at V _{DD} or GND				400		

Notes:

1. Not guaranteed.
2. Duration of test must not exceed one second with only one output tested at a time.

AC Electrical Characteristics

Symbol	Parameter	TA = -40°C to +85°C, CL = 50pF, RL = 500Ω						Units
		VDD = 3.3V ±0.3V		VDD = 2.5V ±0.2V		VDD = 1.8V		
		Min.	Max.	Min.	Max.	Min.	Max.	
t _{PHL} , t _{PLH}	Prop Delay	0.5	2.4	0.5	2.8	1.0	3.6	ns
t _{PZL} , t _{PZH}	Output Enable Time	1.0	2.9	1.0	3.5	1.5	4.5	
t _{PLZ} , t _{PHZ}	Output Disable Time	1.5	3.7	1.0	4.0	1.5	4.8	
t _{OSSL} , t _{OSLH}	Output to Output Skew ⁽¹⁾		0.5		0.5		0.5	

Notes:

1. Skew is defined as the absolute value of the difference between the actual propagation delay for any two separate outputs of the same device. The specification applies to any outputs switching in the same direction, either HIGH or LOW (t_{OSSL}) or LOW to HIGH (t_{OSLH}).

Capacitance

Symbol	Parameter	Conditions	TA = +25°C Typical	Units
C _{IN}	Input Capacitance	V _{DD} = 1.8, 2.5V or 3.3V, V _I = 0V or V _{DD}	6	pF
C _{OUT}	Output Capacitance	V _I = 0V or V _{DD} , V _{DD} = 1.8V, 2.5V or 3.3V	7	
C _{PD}	Power Dissipation Capacitance	V _I = 0V or V _{DD} , F = 10 MHz V _{DD} = 1.8V, 2.5V or 3.3V	20	

Test Circuits and Switching Waveforms

Parameter Measurement Information ($V_{DD} = 1.8V - 3.6V$)

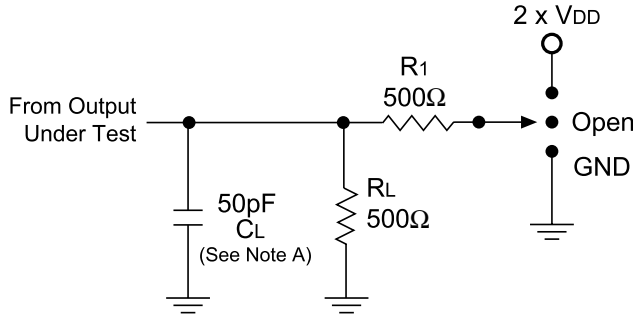

Switch Position

Test	S1
tpd	Open
tPLZ/tPZL	2 x VDD
tPHZ/tPZH	GND

Pulse Width

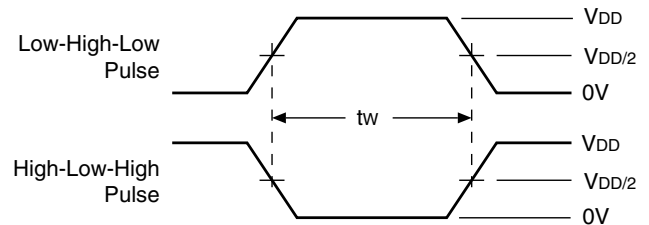

Setup, Hold, and Release Timing

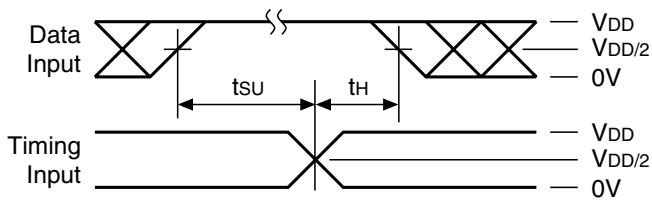

Propagation Delay

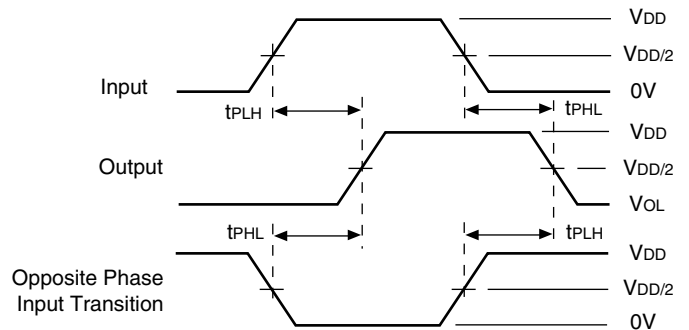

Notes:

- A. C_L includes probe and jig capacitance.
- B. Waveform 1 is for an output with internal conditions such that the output is LOW except when disabled by the output control.
 Waveform 2 is for an output with internal conditions such that the output is HIGH except when disabled by the output control.
- All input pulses are supplied by generators having the following characteristics: $PRR \leq 10 \text{ MHz}$, $Z_o = 50\Omega$, $t_r \leq 2\text{ns}$, $t_f \leq 2\text{ns}$, *measured from 10% to 90%, unless otherwise specified.*
- The outputs are measured one at a time with one transition per measurement.

Enable Disable Timing

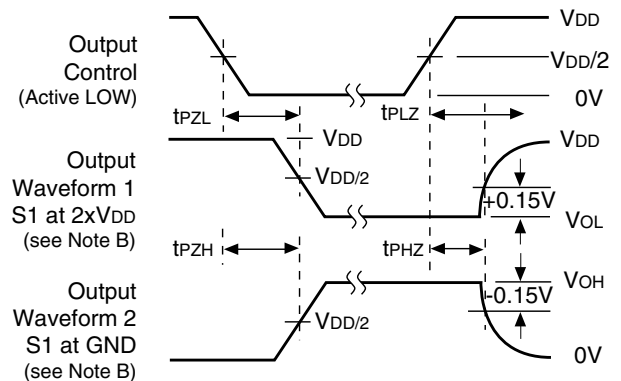

Packaging Mechanical: 48-pin SSOP(V)

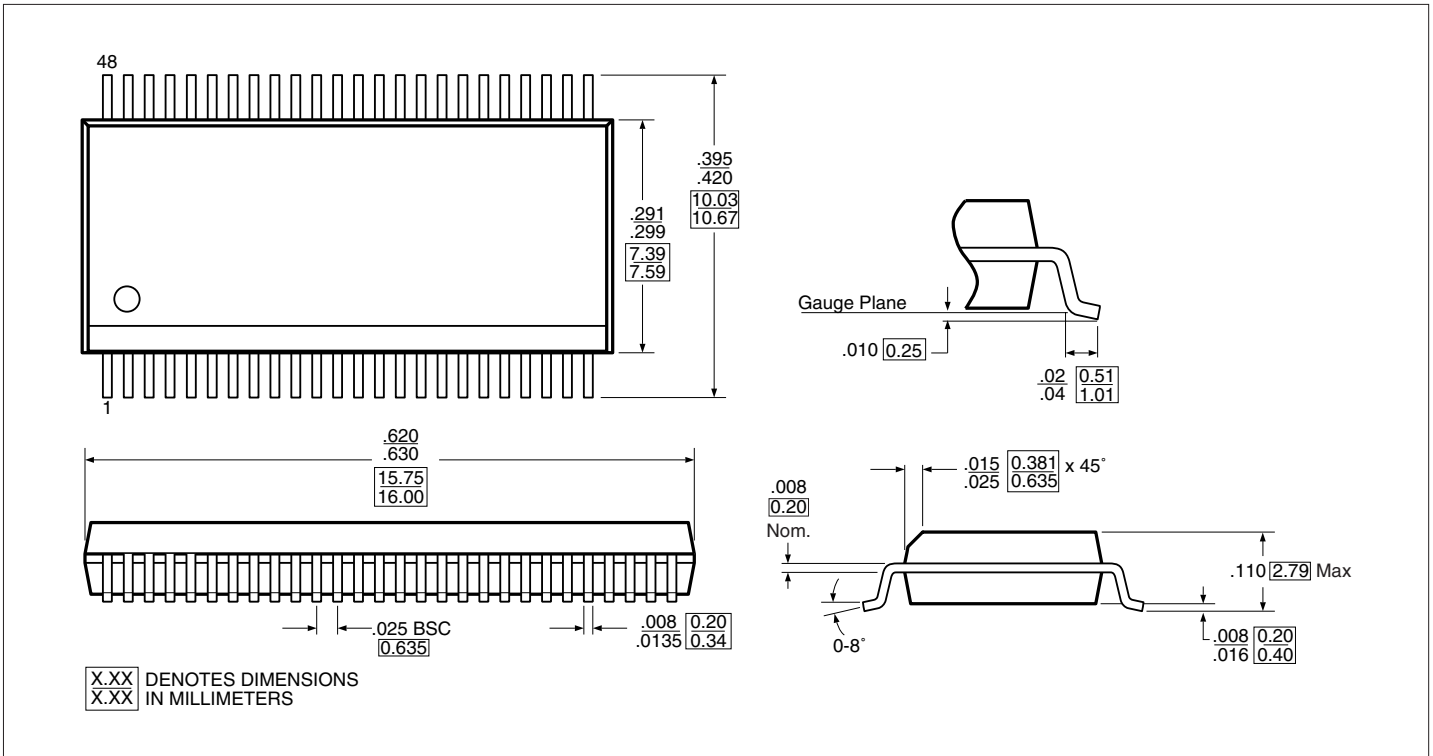

Packaging Mechanical: 48-pin TVSOP(K)

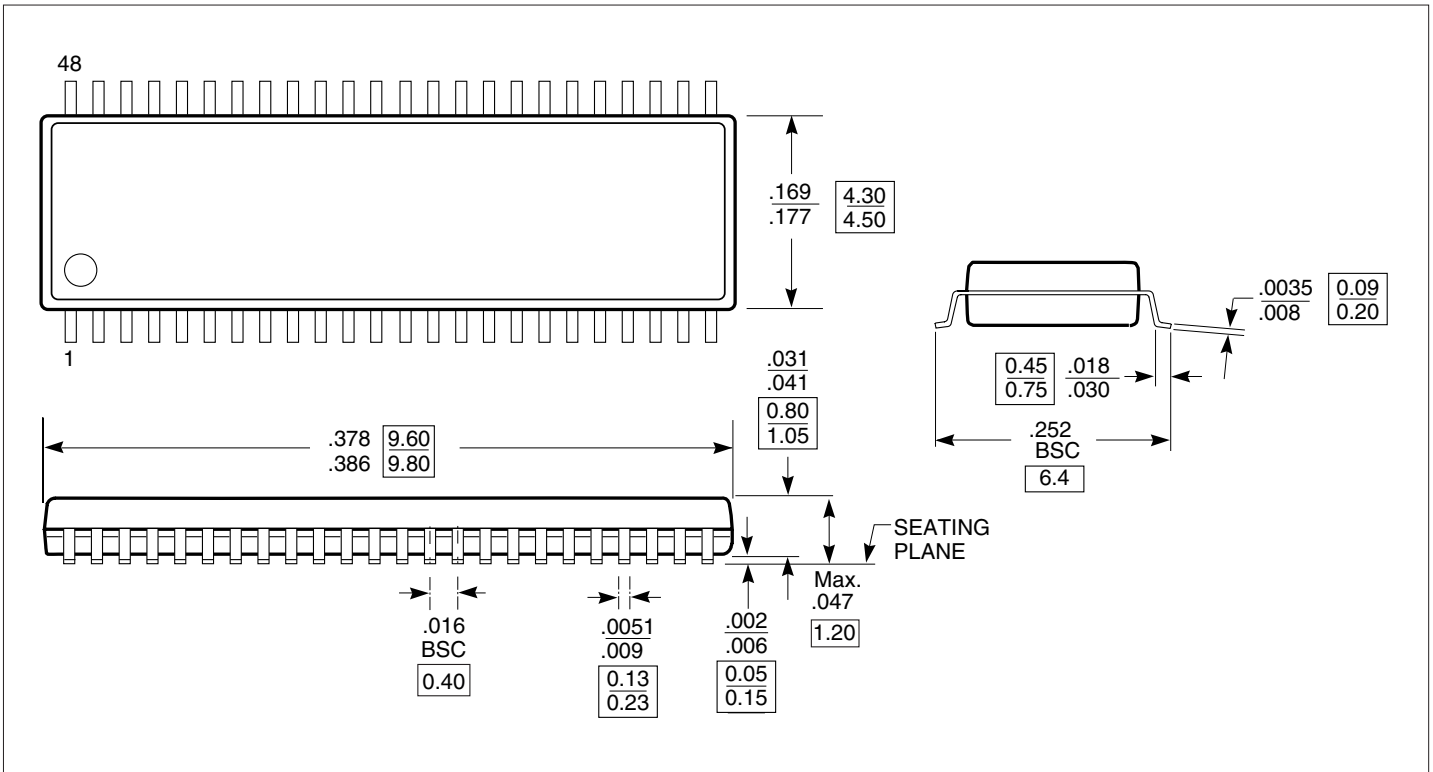

Packaging Mechanical: 48-pin TSSOP (A)

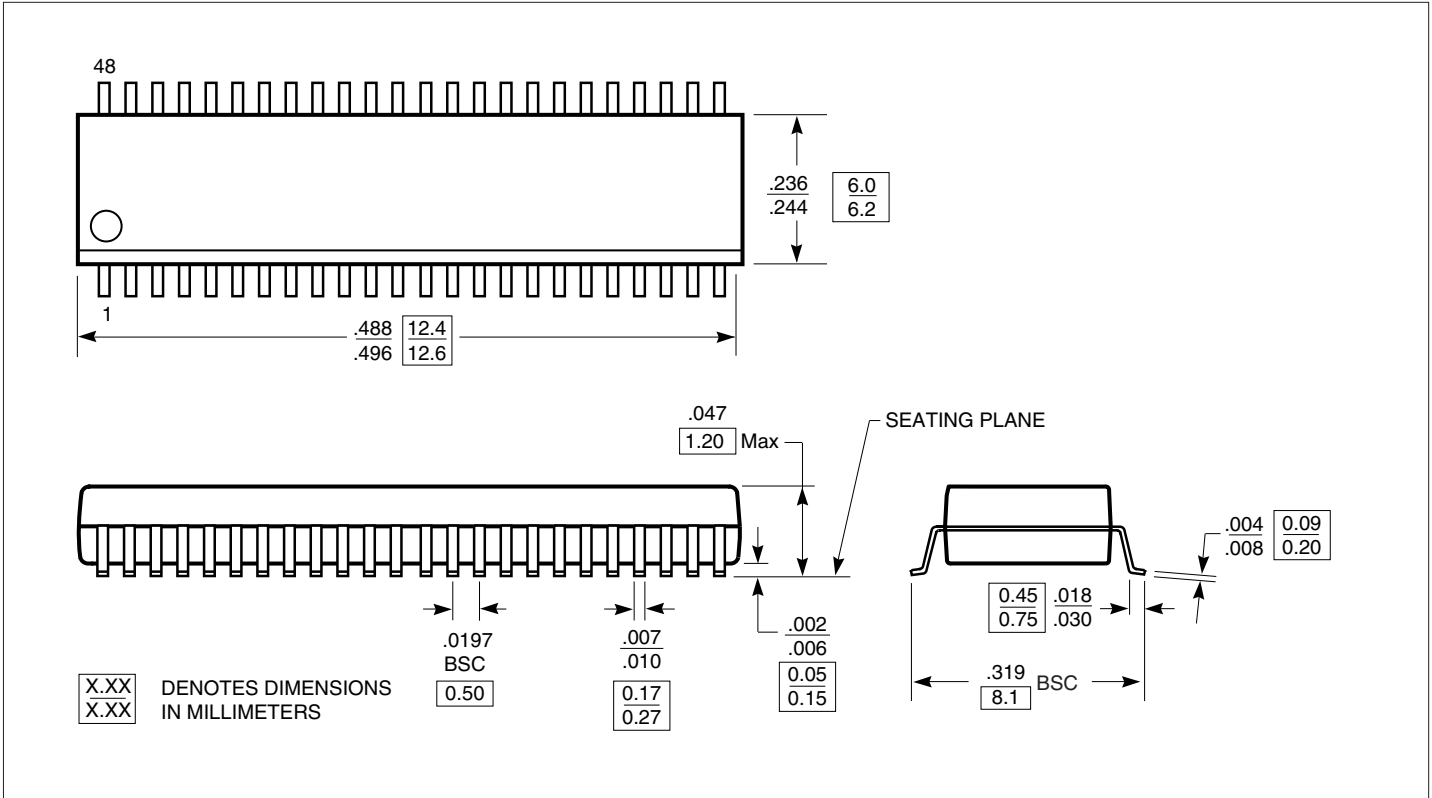

Ordering Information

Ordering Code	Package Code	Package Type
PI74ALVTC16245A	A	48-pin 240-mil wide TSSOP
PI74ALVTC16245AE	A	Pb-free & Green, 48-pin 240-mil wide TSSOP
PI74ALVTC16245V	V	48-pin 300-mil wide SSOP
PI74ALVTC16245VE	V	Pb-free & Green, 48-pin 300-mil wide SSOP
PI74ALVTC16245K	K	48-pin 173-mil wide TVSOP
PI74ALVTC16245KE	K	Pb-free & Green, 48-pin 173-mil wide TVSOP

Notes:

- Thermal characteristics can be found on the company web site at www.pericom.com/packaging/
- E = Pb-free & Green
- Adding an X suffix = Tape/Reel