

PRODUCT NUMBER  
89361-YXXSLF

- LEAD FREE, RoHS COMPLIANT  
SEE NOTE 4
- STRAIN RELIEF OPTION, NOTE 5.
- TOTAL NB OF POSITIONS, SHEET 2.
- FEATURES, SHEET 2.

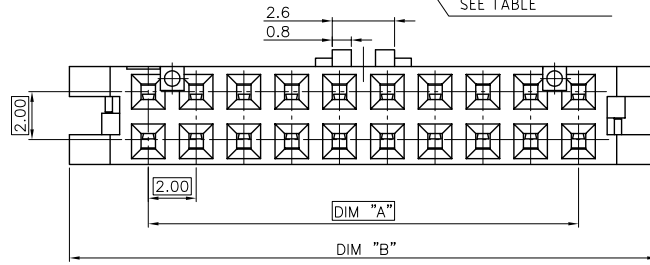
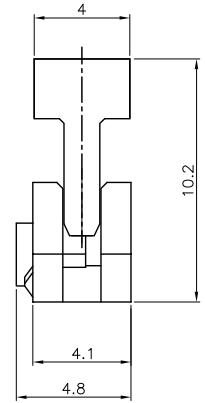
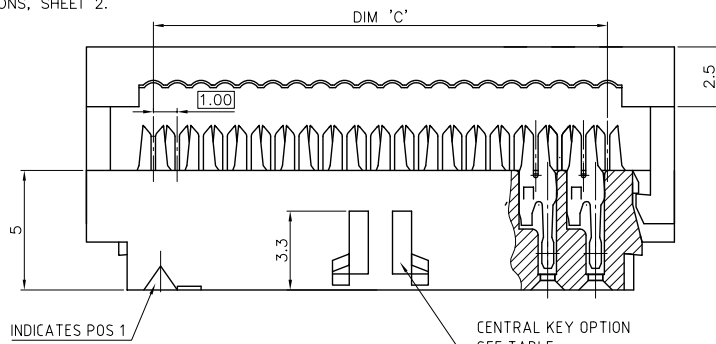

VIEW WITHOUT COVER

mat'l. code		surface	tolerance	projection	product family
SEE NOTE		ISO 1302	ISO 406 ISO 1101		MINITEK
Ltr	ecm no	dr	date	title	
K	F06-0211	LMU	06.07.03	2.00mm IDC	
L	F07-0215	LMU	07.06.12	0.2µm Au	
M	F08-0214	JCO	08.09.09	scale 1:1	
N	F09-0081	JCO	09.08.27	dr	L.MULIN 07.03.20
				eng	J.COMPAGNON 07.03.20
				chr	
				app	JM.C 07.03.20
sheet index	revision sheet	N	N	type Product Customer Drawing	
		1	2		

PDM: Rev:N

STATUS:Released

Printed: Sep 01, 2009



Copyright FCI

form: A3

PRODUCT SIZE	TOTAL NB OF POS	DIM "A"	DIM "B"	DIM "C"	STRAIN RELIEF OPTION
89361-X06LF	2x3	4	10.6	5	YES
-X08LF	2x4	6	12.6	7	YES
-X10LF	2x5	8	14.6	9	YES
-X12LF	2x6	10	16.6	11	YES
-X14LF	2x7	12	18.6	13	YES
-X16LF	2x8	14	20.6	15	YES
-X18LF	2x9	16	22.6	17	YES
-X20LF	2x10	18	24.6	19	YES
-X22LF	2x11	20	26.6	21	NOT TOOLED
-X24LF	2x12	22	28.6	23	YES
-X26LF	2x13	24	30.6	25	YES
-X28LF	2x14	26	32.6	27	NOT TOOLED
-X30LF	2x15	28	34.6	29	YES
-X34LF	2x17	32	38.6	33	YES
-X36LF	2x18	34	40.6	35	NOT TOOLED
-X40LF	2x20	38	44.6	39	YES
-X44LF	2x22	42	48.6	43	YES
-X48LF	2x24	46	52.6	47	YES
-X50LF	2x25	48	54.6	49	YES

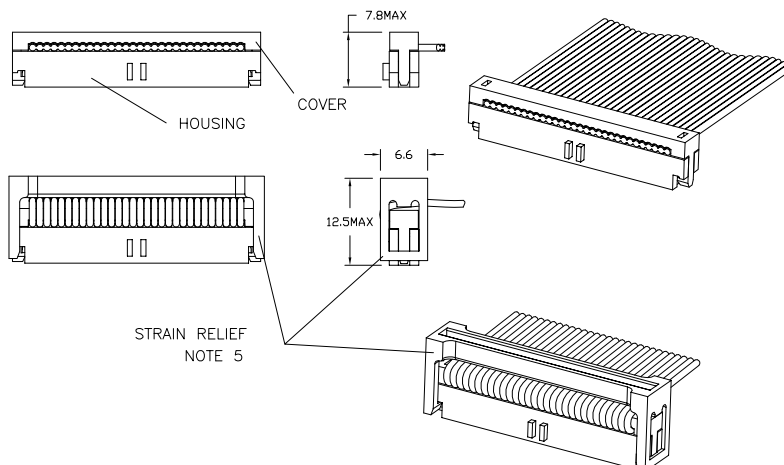

NOTES :

- MATERIAL : TERMINAL PHOSPHORE BRONZE  
BASE AND COVER : PBT GLASSFILLED UL 94V-0 BLACK
- PLATING : GOLD 0.2µm Au MIN ON CONTACT AREA  
NICKEL 1.27µm MIN UNDERPLATING ALL OVER
- RECOMMENDED CABLE SIZE : AWG28, STRANDED
- THIS PRODUCT MEETS EUROPEAN UNION DIRECTIVES AND OTHER COUNTRY REGULATIONS AS PER GS-22-008.  
PACKAGING SPECIFICATION AS PER GS-14-920.
- S= STRAIN RELIEF ACCESSORY, SEE TABLE FOR AVAILABILITY,  
OMIT LETTER FROM PARTNUMBER IF NOT APPLICABLE.

PRODUCT CODE	WITHOUT CENTRAL KEY	WITH CENTRAL KEY	WITH CENTRAL KEY AND FRICTION LATCH BUMP	AVAILABILITY
89361-7XX			○	FROM 2X3 POS UP TO 2X17
89361-3XX		○		FROM 2X17 POS UP TO 2X25
89361-1XX	○			FROM 2x3 POS UP TO 2x25

mat'l. code	surface	tolerance	projection	product family
SEE NOTE	ISO 1302	ISO 406 ISO 1101		
Ltr	ecn no	dr	date	tolerances unless otherwise specified
K	F06-0211	LMU	06.07.03	angles
L	F07-0215	LMU	07.06.12	linear
M	F08-0214	JCO	08.09.09	0±x
N	F09-0081	JCO	09.08.27	0.00±.05
		dr	L.MULIN	07.03.20
		engr	J.COMPAGNON	07.03.20
		chr		
		appd	J.M.C	07.03.20
sheet index	revision sheet			



title  
2.00mm IDC  
0.2µm Au

dwg no  
89361

sheet 2 of 2 size  
A3

type Product Customer Drawing