



6 Lake Street, Lawrence, MA 01841
1-800-446-1158 / (978) 620-2600 / Fax: (978) 689-0803
Website: <http://www.microsemi.com>

TECHNICAL DATA SHEET

Gort Road Business Park, Ennis, Co. Clare, Ireland
Tel: +353 (0) 65 6840044 Fax: +353 (0) 65 6822298

1500 WATT BIDIRECTIONAL TRANSIENT VOLTAGE SUPPRESSOR *Qualified per MIL-PRF-19500/507*

DEVICES

*** 1N6036 thru 1N6072
1N6036A thru 1N6072A**

*** Commercial only**

**LEVELS
JAN
JANTX
JANTXV**

DESCRIPTION

This popular Transient Voltage Suppressor (TVS) series for 1N6036 thru 1N6072A are JEDEC registered selections for bidirectional devices. All have the same high Peak Pulse Power rating of 1500 W with extremely fast response times. They are also available in military qualified selections as described in the Features section herein. They are most often used for protecting against transients from inductive switching environments, induced RF effects, or induced secondary lightning effects as found in lower surge levels of IEC61000-4-5. They are also very successful in protecting airborne avionics and electrical systems. Since their response time is virtually instantaneous, they can also protect from ESD and EFT per IEC61000-4-2 and IEC61000-4-4.

IMPORTANT: For the most current data, consult *MICROSEMI's* website:

<http://www.microsemi.com>



FEATURES

- Bidirectional TVS series for thru-hole mounting
- Suppresses transients up to 1500 watts @ 10/1000 μ s (see Figure 1)
- Clamps transient in less than 100 pico seconds
- Working voltage (V_{WM}) range 5.5 V to 185 V
- Hermetic sealed DO-13 metal package
- JAN/TX/TXV military qualifications also available per MIL-PRF-19500/507 for the tighter tolerance "A" suffix types by adding the JAN, JANTX, or JANTXV prefix, e.g. JANTXV1N6036A, etc.
- For unidirectional TVS in the same DO-13 package, see separate data sheet for the 1N5629 – 1N5665A series (also military qualified)
- Surface mount equivalent packages also available as SMCJ5.0C - SMCJ170CA or SMCG5.0C – SMCG170CA in separate data sheet (consult factory for other surface mount options)
- Plastic axial-leaded equivalents available in the 1.5KE6.8C – 1.5KE220CA series in separate data sheet

DO-13 (DO-202AA)



6 Lake Street, Lawrence, MA 01841
1-800-446-1158 / (978) 620-2600 / Fax: (978) 689-0803
Website: <http://www.microsemi.com>

TECHNICAL DATA SHEET

Gort Road Business Park, Ennis, Co. Clare, Ireland
Tel: +353 (0) 65 6840044 Fax: +353 (0) 65 6822298

APPLICATIONS / BENEFITS

- Protection from switching transients and induced RF
- Protection from ESD & EFT per IEC 61000-4-2 and IEC 61000-4-4
- Secondary lightning protection per IEC61000-4-5 with 42 Ohms source impedance:
 - Class 1: 1N6036 to 1N6072A
 - Class 2: 1N6036 to 1N6067A
 - Class 3: 1N6036 to 1N6061A
 - Class 4: 1N6036 to 1N6054A
- Secondary lightning protection per IEC61000-4-5 with 12 Ohms source impedance:
 - Class 1: 1N6036 to 1N6064A
 - Class 2: 1N6036 to 1N6057A
 - Class 3: 1N6036 to 1N6049A
 - Class 4: 1N6036 to 1N6042A
- Secondary lightning protection per IEC61000-4-5 with 2 Ohms source impedance:
 - Class 2: 1N6036 to 1N6048A
 - Class 3: 1N6036 to 1N6041A
- Inherently radiation hard as described in Microsemi MicroNote 050

MAXIMUM RATINGS

- 1500 Watts for 10/1000 μ s with repetition rate of 0.01% or less* at lead temperature (T_L) 25°C (see Figs 1, 2, & 4)
- Operating & Storage Temperatures: -65° to +175°C
- DC Power Dissipation*: 1 Watt at $T_L \leq +125^\circ\text{C}$ 3/8" (10 mm) from body (see derating in Fig 3 and note below)
- Solder Temperatures: 260 ° C for 10 s (maximum)

MECHANICAL AND PACKAGING

- CASE: DO-13 (DO-202AA), welded, hermetically sealed metal and glass
- FINISH: All external metal surfaces are Tin-Lead plated and solderable per MIL-STD-750 method 2026
- POLARITY: Not applicable for bidirectional TVS
- MARKING: Part number
- WEIGHT: 1.4 grams. (Approx)
- TAPE & REEL option: Standard per EIA-296 (add "TR" suffix to part number)
- See package dimension on last page

* TVS devices are not typically used for dc power dissipation and are instead operated at or less than their rated standoff voltage (V_{WM}) except for transients that briefly drive the device into avalanche breakdown (V_{BR} to V_C region).



TECHNICAL DATA SHEET

6 Lake Street, Lawrence, MA 01841
1-800-446-1158 / (978) 620-2600 / Fax: (978) 689-0803
Website: <http://www.microsemi.com>

Gort Road Business Park, Ennis, Co. Clare, Ireland
Tel: +353 (0) 65 6840044 Fax: +353 (0) 65 6822298

ELECTRICAL CHARACTERISTICS @ 25°C (Test Both Polarities)

JEDEC Type No.	Rated Standoff Voltage V_{WM} (NOTE 1)	Breakdown Voltage $V_{(BR)}$			Maximum Clamping Voltage $V_C @ I_{PP}$	Maximum Standby Current $I_D @ V_{WM}$	Maximum Peak Pulse Current I_{PP} (See Fig. 2)	Maximum Temperature Coefficient of $V_{(BR)}$
		$V_{(BR)}$ min	$V_{(BR)}$ max	@ $I_{(BR)}$				
		Volts	Volts	mA				
1N6036	5.5	6.75	8.25	10	11.7	1000	128	.061
*1N6036A	6.0	7.13	7.88	10	11.3	1000	132	.061
1N6037	6.5	7.38	9.02	10	12.5	500	120	.065
*1N6037A	7.0	7.79	8.61	10	12.1	500	124	.065
1N6038	7.0	8.19	10.00	10	13.8	200	109	.068
*1N6038A	7.5	8.65	9.55	10	13.4	200	112	.068
1N6039	8.0	9.0	11.0	1	15.0	50	100	.073
*1N6039A	8.5	9.5	10.5	1	14.5	50	103	.073
1N6040	8.5	9.9	12.1	1	16.2	10	93	.075
*1N6040A	9.0	10.5	11.6	1	15.6	10	96	.075
1N6041	9.0	10.8	13.2	1	17.3	5	87	.078
*1N6041A	10.0	11.4	12.6	1	16.7	5	90	.078
1N6042	10.0	11.7	14.3	1	19.0	5	79	.081
*1N6042A	11.0	12.4	13.7	1	18.2	5	82	.081
1N6043	11.0	13.5	16.5	1	22.0	5	68	.084
*1N6043A	12.0	14.3	15.8	1	21.2	5	71	.084
1N6044	12.0	14.4	17.5	1	23.5	5	64	.086
*1N6044A	13.0	15.2	16.8	1	22.5	5	67	.086
1N6045	14.0	16.2	19.8	1	26.5	5	56.5	.088
*1N6045A	15.0	17.1	18.9	1	25.2	5	59.5	.088
1N6046	16.0	18.0	22.0	1	29.1	5	51.5	.090
*1N6046A	17.0	19.0	21.0	1	27.7	5	54	.090
1N6047	17.0	19.8	24.2	1	31.9	5	47	.092
*1N6047A	18.0	20.9	23.1	1	30.6	5	49	.092
1N6048	19.0	21.6	26.4	1	34.7	5	43	.094
*1N6048A	20.0	22.8	25.2	1	33.2	5	45	.094
1N6049	21.0	24.3	29.7	1	39.1	5	38.5	.095
*1N6049A	22.0	25.7	28.4	1	37.5	5	40	.096
1N6050	24.0	27.0	33.0	1	43.5	5	34.5	.097
*1N6050A	25.0	28.5	31.5	1	41.4	5	36	.097
1N6051	26.0	29.7	36.3	1	47.7	5	31.5	.098
*1N6051A	28.0	31.4	34.7	1	45.7	5	33	.098
1N6052	29.0	32.4	39.6	1	52.0	5	29	.099
*1N6052A	30.0	34.2	37.8	1	49.9	5	30	.099
1N6053	31.0	35.1	42.9	1	56.4	5	26.5	.100
*1N6053A	33.0	37.1	41.0	1	53.9	5	28	.100
1N6054	34.0	38.7	47.3	1	61.9	5	24	.101
*1N6054A	36.0	40.9	45.2	1	59.3	5	25.3	.101
1N6055	38.0	42.3	51.7	1	67.8	5	22.2	.101
*1N6055A	40.0	44.7	49.4	1	64.8	5	23.2	.101
1N6056	41.0	45.9	56.1	1	73.5	5	20.4	.102
*1N6056A	43.0	48.5	53.6	1	70.1	5	21.4	.102
1N6057	45.0	50.4	61.6	1	80.5	5	18.6	.103
*1N6057A	47.0	53.2	58.8	1	77.0	5	19.5	.103
1N6058	48.0	55.8	68.2	1	89.0	5	16.9	.104
*1N6058A	53.0	58.9	65.1	1	85.0	5	17.7	.104
1N6059	55.0	61.2	74.8	1	98.0	5	15.3	.104
*1N6059A	58.0	64.6	71.4	1	92.0	5	16.3	.104
1N6060	60.0	67.5	82.5	1	108.0	5	13.9	.105
*1N6060A	64.0	71.3	78.8	1	103.0	5	14.6	.105
1N6061	66.0	73.8	90.2	1	118.0	5	12.7	.105
*1N6061A	70.0	77.9	86.1	1	113.0	5	13.3	.105



TECHNICAL DATA SHEET

6 Lake Street, Lawrence, MA 01841
1-800-446-1158 / (978) 620-2600 / Fax: (978) 689-0803
Website: <http://www.microsemi.com>

Gort Road Business Park, Ennis, Co. Clare, Ireland
Tel: +353 (0) 65 6840044 Fax: +353 (0) 65 6822298

ELECTRICAL CHARACTERISTICS @ 25°C (Test Both Polarities)

JEDEC Type No.	Rated Standoff Voltage V_{WM} (NOTE 1)	Breakdown Voltage $V_{(BR)}$			Maximum Clamping Voltage $V_C @ I_{PP}$	Maximum Standby Current $I_D @ V_{WM}$	Maximum Peak Pulse Current I_{PP} (See Fig. 2)	Maximum Temperature Coefficient of $V_{(BR)}$
		$V_{(BR)}$ min	$V_{(BR)}$ max	@ $I_{(BR)}$				
		Volts	Volts	mA				
1N6062	73.0	81.9	100.0	1	131.0	5	11.4	.106
*1N6062A	75.0	86.5	95.5	1	125.0	5	12.0	.106
1N6063	81.0	90.0	110.0	1	144.0	5	10.4	.106
*1N6063A	82.0	95.0	105.0	1	137.0	5	11.0	.106
1N6064	90.0	99.0	121.0	1	158.0	5	9.5	.107
*1N6064A	94.0	105.0	116.0	1	152.0	5	9.9	.107
1N6065	95.0	108.0	132.0	1	176.0	5	8.5	.107
*1N6065A	100.0	114.0	126.0	1	168.0	5	8.9	.107
1N6066	105.0	117.0	143.0	1	191.0	5	7.8	.107
*1N6066A	110.0	124.0	137.0	1	182.0	5	8.2	.107
1N6067	121.0	135.0	165.0	1	223.0	5	6.7	.108
*1N6067A	128.0	143.0	158.0	1	213.0	5	7.0	.108
1N6068	137.0	153.0	187.0	1	258.0	5	5.8	.108
*1N6068A	145.0	162.0	179.0	1	245.0	5	6.1	.108
1N6069	145.0	162.0	198.0	1	274.0	5	5.5	.108
*1N6069A	150.0	171.0	189.0	1	261.0	5	5.7	.108
1N6070	155.0	171.0	210.0	1	292.0	5	5.1	.108
*1N6070A	160.0	181.0	200.0	1	278.0	5	5.4	.108
1N6071	165.0	180.0	220.0	1	308.0	5	4.9	.108
*1N6071A	170.0	190.0	210.0	1	294.0	5	5.1	.108
1N6072	175.0	198.0	242.0	1	344.0	5	4.3	.108
*1N6072A	185.0	209.0	231.0	1	328.0	5	4.6	.108

* Also available in military qualified types by adding the prefix JAN, JANTX or JANTXV per MIL-PRF-19500/507.

NOTE 1: A TVS is normally selected according to the rated "Standoff Voltage" V_{WM} that should be equal to or greater than the dc or continuous peak operating voltage level.

SYMBOLS & DEFINITIONS

Symbol	Definition
V_{WM}	Standoff Voltage: Applied Reverse Voltage to assure a nonconductive condition. (See Note 1 above.)
$V_{(BR)}$	Breakdown Voltage: This is the Breakdown Voltage the device will exhibit at 25°C
V_C	Maximum Clamping Voltage: The maximum peak voltage appearing across the TVS when subjected to the peak pulse current in a one millisecond time interval. The peak pulse voltage is the combination of voltage rise due to both the series resistance and thermal rise and positive temperature coefficient ($\alpha_{V(BR)}$)
I_{PP}	Peak Pulse Current: The peak current during the impulse (See Figure 2)
P_{PP}	Peak Pulse Power: The pulse power as determined by the product of V_C and I_{PP}
I_D	Standby Current: The current at the standoff voltage (V_{WM})
$I_{(BR)}$	Breakdown Current: The current used for measuring Breakdown Voltage ($V_{(BR)}$)

GRAPHS

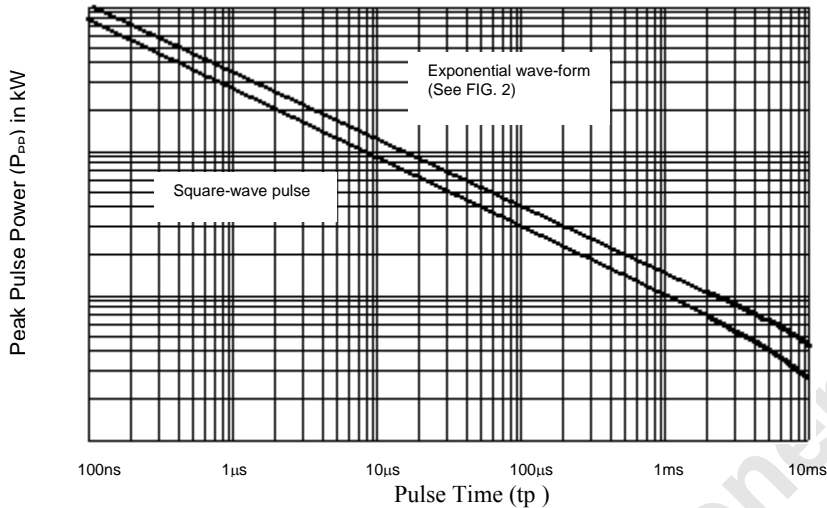

FIG. 1 – Non-repetitive peak pulse power rating curve
NOTE: Peak power defined as peak voltage times peak current

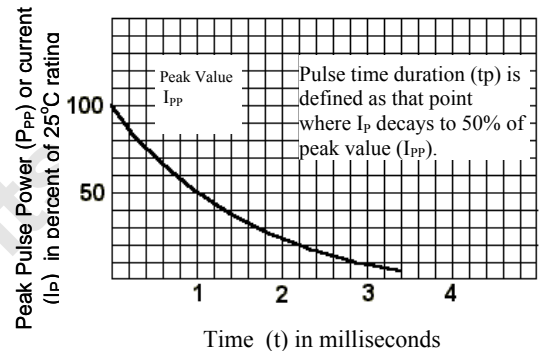

FIG. 2 Pulse wave form for exponential surge

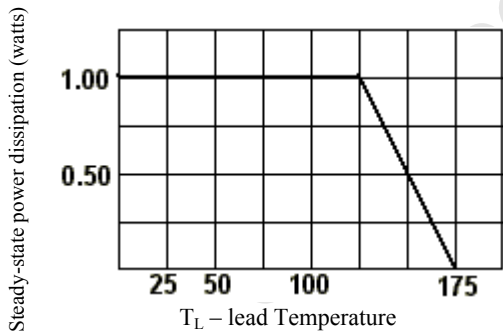
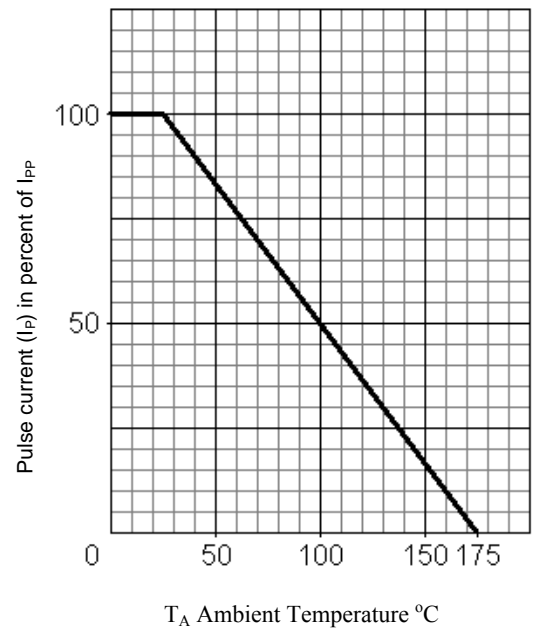

FIG. 3 Steady-state power derating curve



T_A Ambient Temperature °C

FIG. 4 Derating Curve

PACKAGE DIMENSIONS

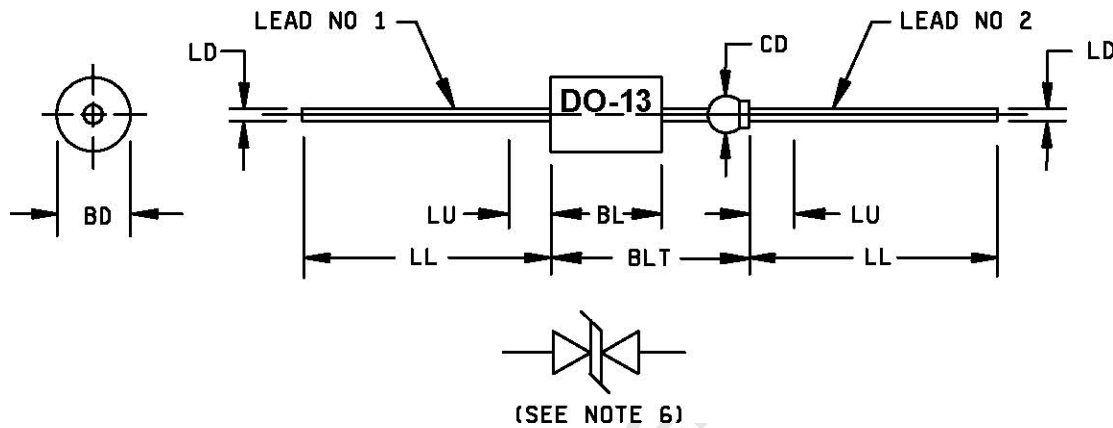

NOTES:

- 1 Dimensions are in inches.
- 2 Millimeter equivalents are given for general information only.
- 3 The major diameter is essentially constant along its length.
- 4 Within this zone, diameter may vary to allow for lead finishes and irregularities.
- 5 Dimension to allow for pinch or seal deformation anywhere along tubulation.
- 6 Symbol for bidirectional transient suppressor.
- 7 Lead 1 shall be electrically connected to the case.
- 8 In accordance with ASME Y14.5M, diameters are equivalent to ϕx symbology.

Symbol	Dimensions				Notes
	Inches		Millimeters		
	Min	Max	Min	Max	
BD	.215	.235	5.46	5.97	
BL	.293	.357	7.44	9.07	3
BLT		.570		14.48	
CD	.045	.100	1.14	2.54	5
LD	.025	.035	0.64	0.89	
LL	1.000	1.625	25.40	41.28	
LU		.188		4.78	4

FIGURE 1. Physical dimensions (DO-13).