



PART NO.: 12-215SYGC/S530-E2/TR8

Device Number : DSE-125-032 REV. 1.0

Chip LEDs with Right Angle Lens

ECN : _____ Page: 1/8

Features :

- Package in 8mm tape on 7" diameter reel.
- Compatible with automatic placement equipment.
- Compatible with infrared and vapor phase reflow solder process.
- Mono-color type.

Descriptions :

- The 12-215 SMD Taping is much smaller than lead frame type components, thus enable smaller board size, higher packing density, reduced storage space and finally smaller equipment to be obtained.
- Besides, light weight makes them ideal for miniature applications, etc.

Applications :

- Automotive: backlighting in dashboard and switch.
- Telecommunication: indicator and backlighting in telephone and fax.
- Flat backlight for LCD, switch and symbol.
- General use.

Package Dimensions :

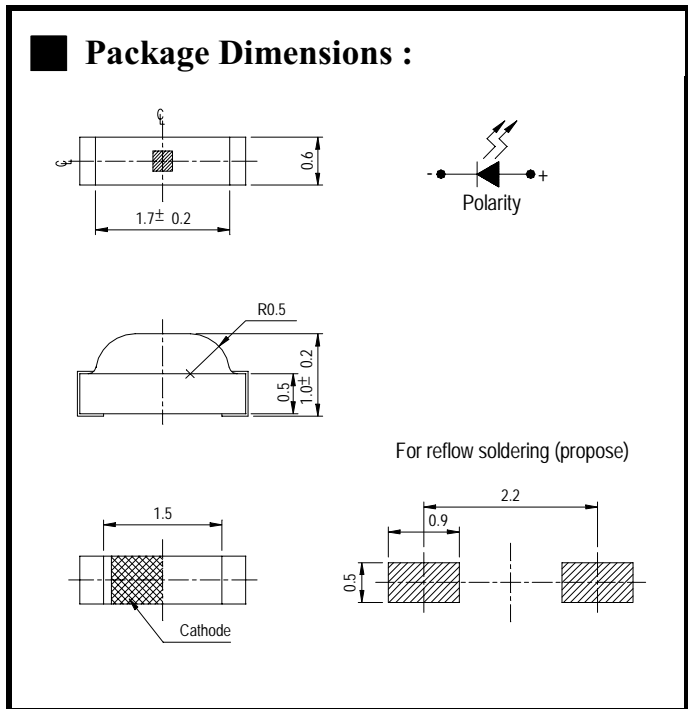

Notes :

Tolerances Unless Dimension ± 0.1 mm
 Angle $\pm 0.5^\circ$
 Unit = mm

PART NO.	Chip		Lens Color
	Material	Emitted Color	
12-215SYGC/S530-E2/TR8	AlGaInP	Super Yellow Green	Water Clear

OFFICE: NO. 25, Lane 76, Sec.3, Chung Yang Rd., Tucheng 236, Taipei, Taiwan, R.O.C.

TEL.: 886-2-2267-2000, 2267-9936

FAX: 886-2-2267-6244, 2267-6189, 2267-6306

<http://www.everlight.com>



PART NO.: 12-215SYGC/S530-E2/TR8

Device Number : DSE-125-032 REV. 1.0

Chip LEDs with Right Angle Lens

ECN : Page: 2/8

■ Package Dimensions :

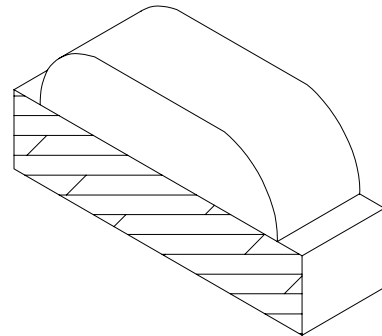
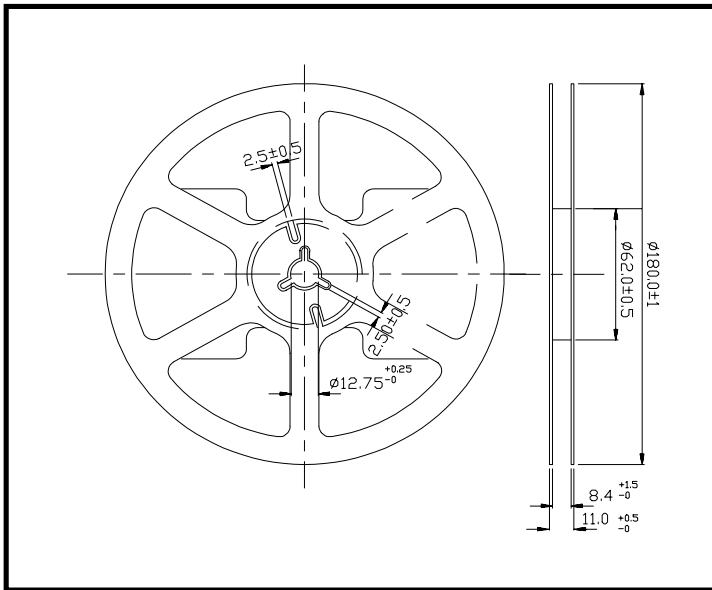

■ Loaded quantity per reel 3000 PCS/reel :

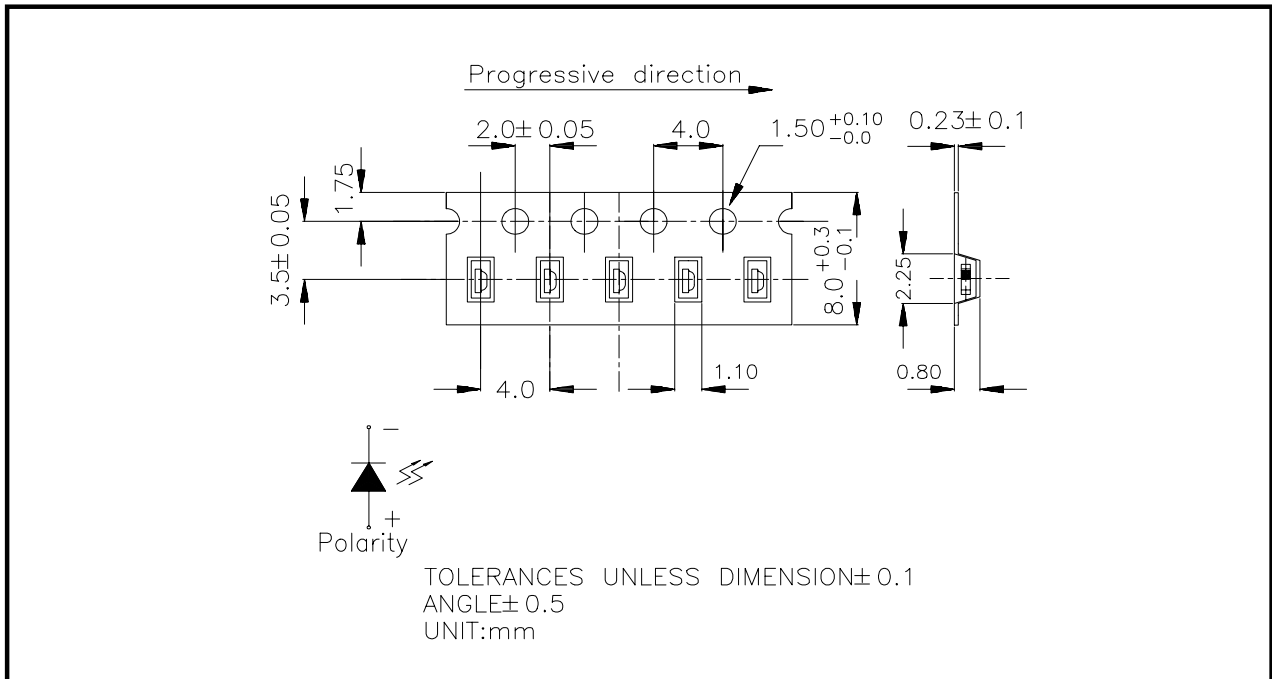

PART NO.: 12-215SYGC/S530-E2/TR8 Device Number : DSE-125-032 REV. 1.0*Chip LEDs with Right Angle Lens*ECN : Page: 3/8**■ Absolute Maximum Ratings at Ta = 25°C**

Parameter	Symbol	Rating	Unit
Reverse Voltage	V _R	5	V
Forward Current	I _F	25	mA
Operating Temperature	T _{opr}	-40 ~ +85	°C
Storage Temperature	T _{stg}	-40 ~ +90	°C
Soldering Temperature	T _{sol}	260 (for 5 second)	°C
Electrostatic discharge	ESD	2000	V
Power Dissipation	P _d	60	mW
Peak Forward Current(Duty 1/10 @ 1KHz)	I _{F(Peak)}	160	mA

■ Electronic Optical Characteristics :

Parameter	Symbol	Min.	Typ.	Max.	Unit	Condition
Luminous Intensity	I _v	-----	2	-----	mcd	I _F =2mA
		20	26	-----		I _F =20mA
Viewing Angle	2θ 1/2	-----	130		deg	I _F =20mA
Peak Wavelength	λ _p	-----	575	-----	nm	I _F =20mA
Dominant Wavelength	λ _d	-----	573	-----	nm	I _F =20mA
Spectrum Radiation Bandwidth	Δλ	-----	20	-----	nm	I _F =20mA
Forward Voltage	V _F	-----	2.0	2.4	V	I _F =20mA
Reverse Current	I _R	-----	-----	10	μA	V _R =5V



PART NO.: 12-215SYGC/S530-E2/TR8

Device Number : DSE-125-032 REV. 1.0

Chip LEDs with Right Angle Lens

ECN : Page: 4/8

Typical Electro-Optical Characteristic Curves

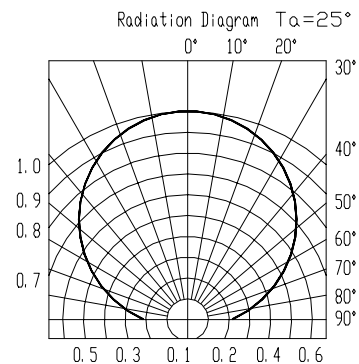
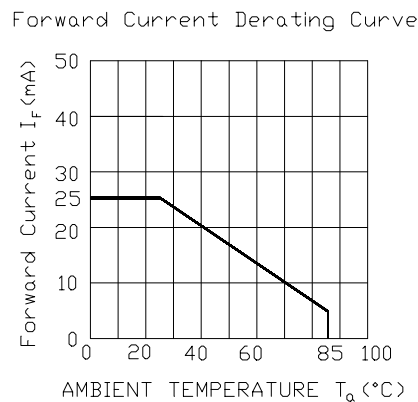
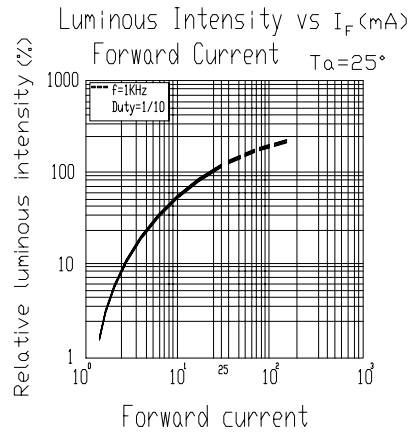
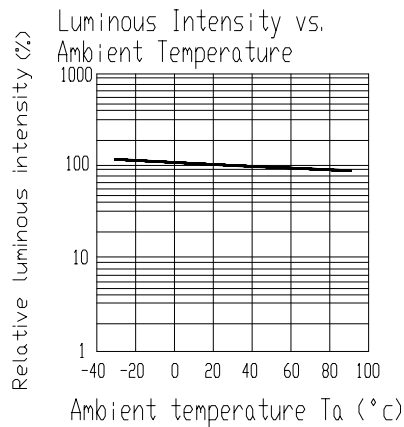
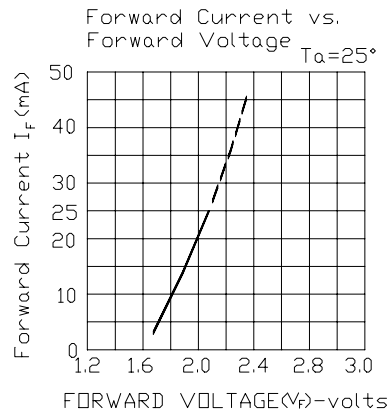
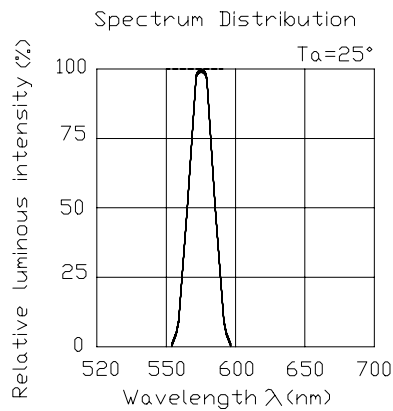



PART NO.: 12-215SYGC/S530-E2/TR8 Device Number : DSE-125-032 REV. 1.0

Chip LEDs with Right Angle Lens

ECN : Page: 5/8

■ Reliability Test Items And Conditions

NO	Item	Test Conditions	Test Hours/Cycle	Sample Size	Ac/Re
1	Solder Heat	TEMP. : 260°C ± 5 °C	5 SEC.	76 PCS	0/1
2	Temperature Cycle	H : +85°C 30min. ∫ 5 min. L : -55°C 30min.	50 CYCLES	76 PCS	0/1
3	Thermal Shock	H : +100°C 5min. ∫ 10 sec. L : -10°C 5min.	50 CYCLES	76 PCS	0/1
4	High Temperature Storage	TEMP. : 100°C	1000 HR.	76 PCS	0/1
5	Low Temperature Storage	TEMP. : -55°C	1000 HR.	76 PCS	0/1
6	DC Operating Life	I _F = 20 mA	1000 HR.	76 PCS	0/1
7	High Temperature / High Humidity	85°C / RH 85%	1000 HR.	76 PCS	0/1



PART NO.: 12-215SYGC/S530-E2/TR8 Device Number : DSE-125-032 REV. 1.0

Chip LEDs with Right Angle Lens

ECN : Page: 6/8

■ Test Circuit

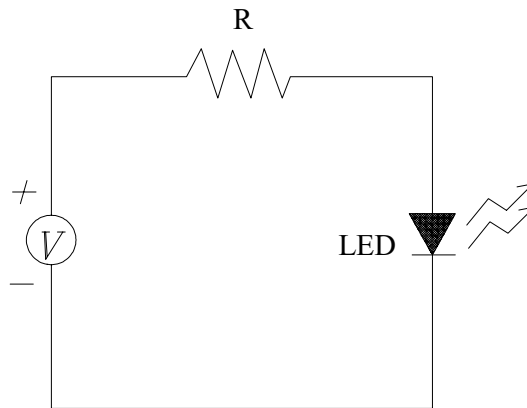

■ Precautions For Use

1. Over-current-proof

Customer must apply resistors for protection , otherwise slight voltage shift will cause big current change (Burn out will happen).

2. Storage time

2.1 The operation of temperature and RH are : $5^{\circ}\text{C}\sim 35^{\circ}\text{C}$, RH60%.

2.2 Once the package is opened, the products should be used within a week.

Otherwise, they should be kept in a damp proof box with desiccating agent.

Considering the tape life , we suggest our customers to use our products within a year(from production date).

2.3 If opened more than one week in an atmosphere $5^{\circ}\text{C}\sim 35^{\circ}\text{C}$, RH60% , they should be treated at $60^{\circ}\text{C}\pm 5^{\circ}\text{C}$ for 15hrs.

2.4 When you discover that the desiccant in the package has a pink color (Normal = blue), you should treat them in the same conditions as 2.3.

PART NO.: 12-215SYGC/S530-E2/TR8 Device Number : DSE-125-032 REV. 1.0

Chip LEDs with Right Angle Lens

ECN : Page: 7/8

■ **Soldering heat reliability (DIP)**

Please refer to the following figure :

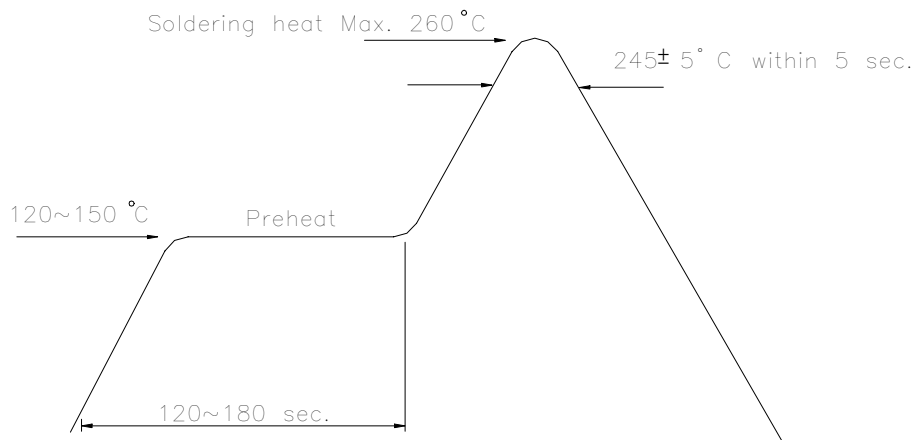

■ **Soldering Iron**

Basic spec is ≤ 5 sec. when 260°C . If temperature is higher, time should be shorter ($+10^{\circ}\text{C} \rightarrow -1$ sec.). Power dissipation of iron should be smaller than 15 W , and temperature should be controllable. Surface temperature of the device should be under 230°C .

■ **Rework**

1. Customer must finish rework within 5 sec. under 260°C .
2. The head of iron can not touch copper foil.
3. Twin-head type is preferred.

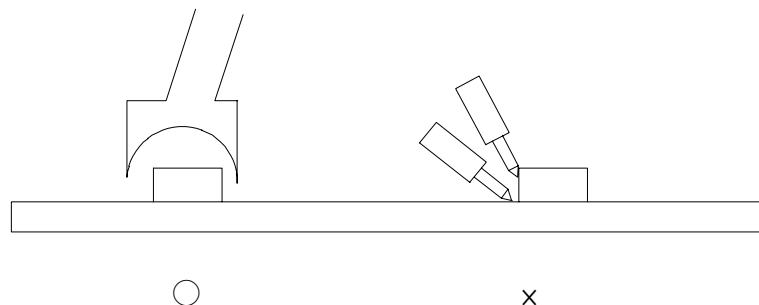



PART NO.: 12-215SYGC/S530-E2/TR8 Device Number : DSE-125-032 REV. 1.0
Chip LEDs with Right Angle Lens

ECN : Page: 8/8

■ Reflow Temp./Time :

