

# Finisar

## Product Specification

### WDM Multi-rate GBIC Transceiver with APD Receiver

#### FTR-1621-XX

#### PRODUCT FEATURES

- All Metro data protocols from 125Mb/s to 2.7 Gb/s
- Extended link budget of **30dB** with APD receiver technology
- Standard GBIC footprint
- Uncooled CWDM-rated DFB laser transmitter
- Class 1 laser safety
- Very low jitter
- Metal enclosure for lower EMI
- Extended voltage range
- Low power dissipation
- Extended operating temperature range: 0°C to 60°C



#### APPLICATIONS

- Metro Access Rings and Point-to-Point networking for SONET, Gigabit Ethernet and Fibre Channel

Finisar's FTR-1621-XX WDM GBIC transceivers comply with GBIC Specification Revision 5.4<sup>1\*</sup>. They are compatible with the single and double rate Fibre Channel FC-PH, PH2, PH3<sup>3\*</sup> and SONET specifications for OC-12/OC-48<sup>3\*\*</sup>. The fiber link budget has been enhanced to 30dB with an Avalanche Photo Diode (APD) receiver. Additional real time diagnostic functions are also available via the 2-wire serial bus specified for Module Definition "4" GBICs. For details, see Finisar Application Note AN-2030<sup>4</sup>. Even with all of these innovative features, the transceiver is still compliant with the mechanical and electrical interfaces defined in the GBIC interoperability standard.

**PRODUCT SELECTION****FTR-1621-XX**

Wavelength	XX	Color Code Dot	Wavelength	XX	Color Code Dot
1470 nm	47	Gray	1550 nm	55	Yellow
1490 nm	49	Violet	1570 nm	57	Orange
1510 nm	51	Blue	1590 nm	59	Red
1530 nm	53	Green	1610 nm	61	Brown

**I. Pin Out**

Pin Name	Pin #	Sequence
RX_LOS	1	2
GND	2	2
GND	3	2
MOD_DEF(0)	4	2
MOD_DEF(1)	5	2
MOD_DEF(2)	6	2
TX_DISABLE	7	2
GND	8	2
GND	9	2
TX_FAULT	10	2
GND	11	1
-RX_DAT	12	1
+RX_DAT	13	1
GND	14	1
V <sub>CC</sub>	15	2
V <sub>CC</sub>	16	2
GND	17	1
+TX_DAT	18	1
-TX_DAT	19	1
GND	20	1

**Table 1. GBIC to host connector pin assignment**

“Sequence” indicates the order in which pins make contact when the device is hot plugged.

Also see “Table 3: Signal Definitions” in the GBIC Specification Revision 5.4.<sup>1</sup>

## II. Electrical Power Interface

Finisar FTR-1621-XX WDM GBIC modules have a power supply voltage range of 4.75V to 5.25V as described in Table 2.

Electrical Power Interface						
Parameter	Symbol	Min	Typ	Max	Units	Notes/Conditions
Supply Current	$I_s$		280	350	mA	
Maximum Voltage	$V_{max}$			6	V	
Surge Current	$I_{surge}$			400	mA	
Input Voltage	$V_{cc}$	4.75	5.00	5.25	V	Referenced to GND
Power Supply Rejection	PSR	100			mV	See Note 1. Peak to Peak

**Table 2. Electrical power interface**

**Note 1: Receiver sensitivity is compliant with power supply sinusoidal of 20 Hz to 1.5Mhz up to specified value applied through the recommended power supply filtering network**

## III. Low Speed Signals

RX\_LOS, TX\_DISABLE, and TX\_FAULT are TTL signals as described in Table 3. MOD\_DEF(1) (SCL) and MOD\_DEF(2) (SDA) are open drain CMOS signals (see section VI, “Serial Communication Protocol”). Both MOD\_DEF(1) and MOD\_DEF(2) must be pulled up to host\_Vcc. Note – MOD\_DEF(0) is grounded inside the GBIC to indicate the correct mode of operation.

For more detailed information, see sections 5.3.1 – 5.3.8 in the GBIC Specification Rev. 5.4<sup>1</sup>.

Low Speed Signals, Electronic Characteristics						
Parameter	Symbol	Min	Max	Units	Notes/Conditions	
GBIC Output LOW	$V_{OL}$	0	0.5	V	4.7k to 10k pull-up to host_Vcc, measured at host side of connector	
GBIC Output HIGH	$V_{OH}$	host_Vcc - 0.5	host_Vcc + 0.3	V	4.7k to 10k pull-up to host_Vcc, measured at host side of connector	
GBIC Input LOW	$V_{IL}$	0	0.8	V	4.7k to 10k pull-up to Vcc, measured at GBIC side of connector	
GBIC Input HIGH	$V_{IH}$	2	Vcc + 0.3	V	4.7k to 10k pull-up to Vcc, measured at GBIC side of connector	

**Table 3. Low speed signals – electronic characteristics**

Low Speed Signal Parameters						
Parameter	Symbol	Min	Typ	Max	Units	Notes/Conditions
RX_LOS Assert Level	--	-42	-39		dBm	Measured on Finisar Eval Card
RX_LOS Deassert Level	--		-37	-32	dBm	Measured on Finisar Eval Card
RX_LOS Hysteresis	--		1.0		dB	Measured on Finisar Eval Card
RX_LOS Assert Delay	t_loss_on			100	μsec	From detection of loss of signal to assertion of RX_LOS
RX_LOS Negate Delay	t_loss_off			150	μsec	From detection of presence of signal to negation of RX_LOS
TX_DISABLE Assert Time	t_off			1000	μsec	Rising edge of TX_DISABLE to fall of output signal below 10% of nominal
TX_DISABLE Negate Time	t_on			1000	μsec	Falling edge of TX_DISABLE to rise of output signal above 90% of nominal
TX_DISABLE Reset Time	t_reset	10			μsec	TX_DISABLE HIGH before TX_DISABLE set LOW

Table 4. Low speed signal parameters

#### IV. High Speed Electrical Interface

All high-speed PECL signals are AC coupled internally.

High Speed Electrical Interface						
Parameter	Symbol	Min	Typ	Max	Units	Notes/Conditions
Data Input Voltage	V <sub>in</sub>	650		2000	mV	PECL differential peak - peak
Data Output Voltage	V <sub>out</sub>	370		2000	mV	PECL differential peak - peak
Duty Cycle	--		50		%	
PECL rise/fall	T <sub>r</sub> , T <sub>f</sub>			150	psec	20%-80% Differential
Bit Error Rate	BER			10 <sup>-12</sup>		PRBS 2 <sup>23</sup> - 1 test data pattern
Tx Input Impedance	Z <sub>in</sub>		75		ohm	Singled ended impedance
Rx Output Impedance	Z <sub>out</sub>		75		ohm	Singled ended impedance

Table 5. High speed electrical interface

**V. Optical Parameters**

Optical Parameters						
Parameter	Symbol	Min	Typ	Max	Units	Notes/Conditions
Transmitter Center Wavelength	$\lambda_c$	(x-4)	(x+1)	(x+6)	nm	Over temperature 0 to 60 °C case temperature. See Note 1 below
Wavelength Temperature Dependence			0.08		nm/°C	
Side Mode Suppression Ratio (SMSR)	SMSR	30			dB	
Transmitter Optical Output Power	$P_{out}$	+1.0	+3.0	+5	dBm	Average power coupled into single mode fiber
Transmitter Extinction Ratio	OMI	8.2			dB	
Transmitter Eye Opening	--	10			%	OC-48 Eye Mask Margin
Optical Return Loss	ORL	14			dB	
Transmitter Jitter				60	ps	Parameter per GR-253 section 5.6 for OC-48
Optical Input Wavelength	$\lambda_{in}$	1450		1620	nm	
Receiver Optical Input Power (BER < 10 <sup>-9</sup> w/ PRBS 2 <sup>23</sup> - 1)	$P_{in}$	-28.0	-30.0	-7	dBm	@ 2.5Gb/s, measured
Receiver Optical Input Power (BER < 10 <sup>-12</sup> w/ PRBS 2 <sup>23</sup> - 1)	$P_{in}$	-27.0	-28.0	-7	dBm	@ 2.5Gb/s, calculated
Transmitter Reflectance				-27	dB	
Dispersion Penalty at 60km				2.0	dB	
Dispersion Penalty at 100km				3.0	dB	

**Table 6. Optical parameters**

**Note 1:** The Transmitter Center Wavelength “x” is as specified by the customer. The current available wavelengths are: 1470, 1490, 1510, 1530, 1550, 1570, 1590, and 1610 nm. Please see the “Product Selection” section on page 2.

**Note 2:** Parameters are specified over temperature and at end of life unless otherwise noted.

**Note 3:** All parameters are measured on a Finisar GBIC Evaluation Card unless otherwise noted.

**Note 4:** The module shall meet all specifications while subjected to this reflection at its optical output.

**VI. General Specifications**

General						
Parameter	Symbol	Min	Typ	Max	Units	Notes/Conditions
Data Rate	BR	0.125		2.7	Gb/sec	Fibre Channel, IEEE 802.3, SONET OC-3/12/48 Compatible
Total System Budget	--	27	31		dB	@2.5 Gb/s, BER <math>10^{-12}</math> w/PRBS $2^{-23}-1</math>. See Note 1$

Note 1: Total system budget is defined as  $P_{out} - P_{in}$  - typical connector losses

**Table 7. General specifications****VII. Environmental Specifications**

Note that the GBIC Specification requires an ambient temperature range of 0 to +50°C. Finisar FTR-1621-XX GBICs have an extended range from 0°C to +60°C case temperature as specified in Table 8.

Environment						
Parameter	Symbol	Min	Typ	Max	Units	Notes/Conditions
Operating Temp	$T_{op}$	0		60	°C	Case temperature
Storage Temp	$T_{sto}$	-10		85	°C	
Eye Safety	--					CDRH and IEC-825 Class 1 Laser Product Note 1

Note 1: Complies with FDA performance standards for laser products except for deviations pursuant to Laser Notice No. 50, dated July 26, 2001.

**Table 8. Environmental specifications**

## VIII. Serial Communication Protocol

All Finisar optical GBICs are ‘Module Definition “4”’ and support the 2 wire serial communication protocol outlined in the GBIC Specification <sup>1</sup>. These GBICs use an Atmel AT24C01A 128 byte E<sup>2</sup>PROM (with an address of 1010000X). For details on interfacing with the E<sup>2</sup>PROM, see the Atmel data sheet titled “AT24C01A/02/04/08/16 2-Wire Serial CMOS E<sup>2</sup>PROM.”<sup>5</sup>

All Finisar optical GBICs also incorporate a microcontroller that monitors system parameters such as laser current, laser temperature, and, in the case of 13xx/14xx/15xx/16xx nm parts, transmitted power. For a complete description of how to use Finisar’s extended features, see Finisar’s Application Note AN-2030<sup>4</sup>.

**CAUTION:** The microcontroller implements the Philips I<sup>2</sup>C protocol including clock stretching. For details, consult the Philips I<sup>2</sup>C-Bus Specification. Clock stretching allows a fast master to communicate with a slow slave device, and it requires that the host monitor the clock line every time it releases the line high. If a host does not implement clock stretching (drives the bus blind), it must run the clock below 8kHz, so that Finisar’s microcontroller has time to process instructions. If clock stretching is supported, the clock may be run at up to 100kHz.

I <sup>2</sup> C Timing Requirements						
Parameter	Symbol	Min	Typ	Max	Units	Notes/Conditions
Atmel I <sup>2</sup> C Clock Rate	C <sub>atmel</sub>	0		100,000	Hz	Bus can be driven blind.
Finisar Microcontroller I <sup>2</sup> C Clock Rate	C <sub>1</sub>	10		100,000	Hz	Host must support clock stretching. Microcontroller times out if C < 10Hz.
Finisar Microcontroller I <sup>2</sup> C Clock Rate	C <sub>2</sub>	10		8000	Hz	Bus can be driven blind. Microcontroller times out if C < 10Hz.

**Table 9. I<sup>2</sup>C timing requirements**

**IX. Mechanical Specifications**

Finisar WDM GBICs conform to the mechanical specifications outlined in the GBIC Specification Revision 5.4, Section 6<sup>1</sup>.

Insertion, Extraction, and Retention Forces						
Parameter	Symbol	Min	Typ	Max	Units	Notes/Conditions
GBIC insertion	F <sub>I</sub>	0		20	Newtons	~4.5 lbs
GBIC extraction	F <sub>E</sub>	0		15	Newtons	~3.3 lbs
GBIC retention	F <sub>R</sub>	130		N/A	Newtons	straight out ~29.3 lbs

**Table 10. Insertion, extraction, and retention forces**

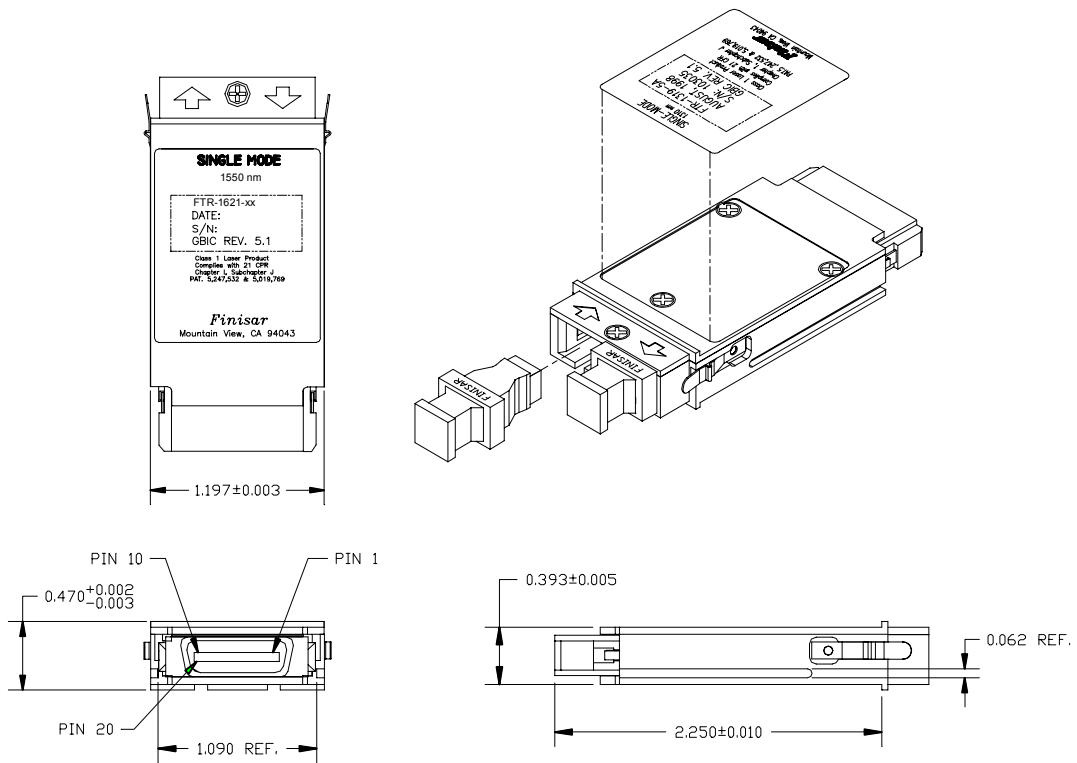

**Figure 1. WDM GBIC outline drawing**



## X. References

1. "Gigabit Interface Converter (GBIC) Revision 5.4".<sup>(\*)</sup> Sun Microsystems Computer Company et. al., August 16, 1999. <http://playground.sun.com/pub/OEmod/>
2. "Fibre Channel Physical and Signaling Interface (FC-PH, FC-PH2, FC-PH3)". American National Standard for Information Systems.
3. Bellcore GR-253 and ITU-T G.957 Specifications (Transmitter Optical Output Power complies with SONET OC-48 LR requirements only).<sup>(\*\*)</sup>
4. "Application Note AN-2030: Digital Diagnostic Monitoring Interface for Optical Transceivers", Finisar Corporation, April 2002.
5. "AT24C01A/02/04/08/16 2-Wire Serial CMOS E<sup>2</sup>PROM". Atmel Corporation. [www.Atmel.com](http://www.Atmel.com)

(\*) Neither GBIC, FC-PH, nor IEEE802.3 specifies a 14xx/15xx/16xx nm single mode interface. The FTR-1621-XX complies with these specifications except for the following optical parameters: laser wavelength, receiver sensitivity, and transmit output power. See Table 6 for details.

(\*\*) The FTR-1621-XX optical interface is not fully SONET/SDH compliant. Please see Table 6.

## XI. For More Information

Finisar Corporation  
1308 Moffett Park Drive  
Sunnyvale, CA 94089-1133  
Tel. (408) 548-1000  
Fax (408) 541-6138  
[sales@finisar.com](mailto:sales@finisar.com)  
[www.finisar.com](http://www.finisar.com)