

General Description

The MIC809 and MIC810 are inexpensive microprocessor supervisory circuits that monitor power supplies in microprocessor based systems.

The function of these devices is to assert a reset if the power supply drops below a designated reset threshold level. Several different reset threshold levels are available to accommodate 3V, 3.3V or 5V powered systems.

The MIC809 has an active-low /RESET output, while the MIC810 offers an active-high RESET output. The reset output is guaranteed to remain asserted for a minimum of 140ms after V_{CC} has risen above the designated reset threshold level. Having a push-pull output stage, the MIC809/810 does not require a pull-up resistor at the output. The MIC809/810 comes in a 3-pin SOT-23 and SC-70 package.

The MIC809 is also available with a shorter reset timeout (30ms min.). See the MIC809-5.

All support documentation can be found on Micrel's web site at www.micrel.com.

Features

- Precision voltage monitor for 3V, 3.3V or 5V power supplies
- /RESET remains valid with V_{CC} as low as 1.4V for SOT-23 packaged part
- /RESET remains valid with V_{CC} as low as 1V for SC70 packaged part
- Typically less than 15 μ A supply current for SOT-23 packaged part
- 5 μ typical supply current for SC70 packaged part
- 140ms minimum reset pulse widths available
- Available in 3-pin SOT-23 and SC-70 package

Applications

- Portable equipment
- Intelligent instruments
- Critical microprocessor power monitoring
- Printers/computers
- Controllers

Typical Application

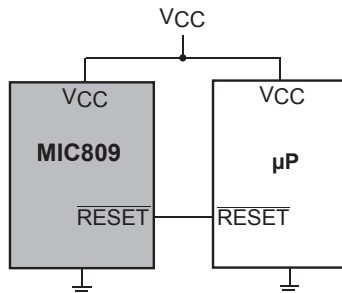

Ordering Information

Part Number		Marking	Threshold Voltage	Operating Temp. Range	Lead Finish
3-lead SOT-23 Package	3-lead SC-70 Package				
MIC809LU	MIC809LBC3	IL	4.63	-40°C to +85°C	Standard
MIC809MU	MIC809MBC3	IM	4.38	-40°C to +85°C	Standard
MIC809JU	MIC809JBC3	IJ	4.00	-40°C to +85°C	Standard
MIC809TU	MIC809TBC3	IT	3.08	-40°C to +85°C	Standard
MIC809SU	MIC809SBC3	IS	2.93	-40°C to +85°C	Standard
MIC809RU	MIC809RBC3	IR	2.63	-40°C to +85°C	Standard
MIC810LU	MIC810LBC3	JL	4.63	-40°C to +85°C	Standard
MIC810MU	MIC810MBC3	JM	4.38	-40°C to +85°C	Standard
MIC810JU	MIC810JBC3	JJ	4.00	-40°C to +85°C	Standard
MIC810TU	MIC810TBC3	JT	3.08	-40°C to +85°C	Standard
MIC810SU	MIC810SBC3	JS	2.93	-40°C to +85°C	Standard
MIC810RU	MIC810RBC3	JR	2.63	-40°C to +85°C	Standard
MIC809LUY	MIC809LYC3	<u>IL</u>	4.63	-40°C to +85°C	Pb-Free
MIC809MUY	MIC809MYC3	<u>IM</u>	4.38	-40°C to +85°C	Pb-Free
MIC809JUY	MIC809JYC3	<u>IJ</u>	4.00	-40°C to +85°C	Pb-Free
MIC809TUY	MIC809TYC3	<u>IT</u>	3.08	-40°C to +85°C	Pb-Free
MIC809SUY	MIC809SYC3	<u>IS</u>	2.93	-40°C to +85°C	Pb-Free
MIC809RUY	MIC809RYC3	<u>IR</u>	2.63	-40°C to +85°C	Pb-Free
MIC810LUY	MIC810LYC3	<u>JL</u>	4.63	-40°C to +85°C	Pb-Free
MIC810MUY	MIC810MYC3	<u>JM</u>	4.38	-40°C to +85°C	Pb-Free
MIC810JUY	MIC810JYC3	<u>JJ</u>	4.00	-40°C to +85°C	Pb-Free
MIC810TUY	MIC810TYC3	<u>JT</u>	3.08	-40°C to +85°C	Pb-Free
MIC810SUY	MIC810SYC3	<u>JS</u>	2.93	-40°C to +85°C	Pb-Free
MIC810RUY	MIC810RYC3	<u>JR</u>	2.63	-40°C to +85°C	Pb-Free

Note: Contact factory for SC70 packaged Pb-free options..

Pin Configuration

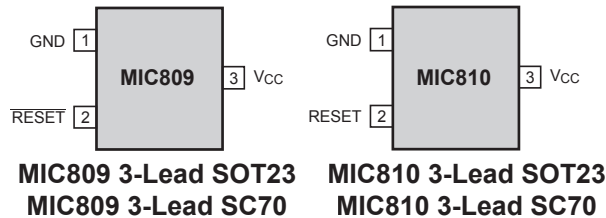

Pin Description

Pin Number MIC809	Pin Number MIC810	Pin Name	Pin Function
1	1	GND	IC Ground Pin.
2	N/A	/RESET	/RESET goes low if V_{CC} falls below the reset threshold and remains asserted for one reset timeout period (140ms min.) after V_{CC} exceeds the reset threshold.
N/A	2	RESET	RESET goes high if V_{CC} falls below the reset threshold and remains asserted for one reset timeout period (140ms min.) after V_{CC} exceeds the reset threshold.
3	3	VCC	Power Supply Input.

Absolute Maximum Ratings⁽¹⁾

Terminal Voltage (V_{CC}).....	-0.3V to 6.0V
Input Current (V_{CC}).....	20mA
Output Current (RESET, /RESET).....	20mA
Lead Temperature (soldering, 10 sec.).....	300°C
Storage Temperature (T_S).....	-65°C to 150°C
Rate of Rise (V_{CC}).....	100V/ μ s
ESD Rating ⁽³⁾	3kV (SC70 Package)

Operating Ratings⁽²⁾

Operating Temperature Range	
MIC809.....	-40°C to 85°C
MIC810.....	-40°C to 85°C
Power Dissipation ($T_A = +70^\circ\text{C}$).....	320mW

Electrical Characteristics⁽⁴⁾

For typical values, $V_{CC} = 5\text{V}$ for MIC8_L/M/J, $V_{CC} = 3.3\text{V}$ for MIC8_S/T, $V_{CC} = 3\text{V}$ for MIC8_R; $T_A = 25^\circ\text{C}$, **bold** values indicate $-40^\circ\text{C} \leq T_A \leq +85^\circ\text{C}$; unless noted.

Symbol	Parameter	Condition	Min	Typ	Max	Units
V_{CC}	Operating Voltage Range	$T_A = 0^\circ\text{C}$ to 70°C SOT-23 package	1.4		5.5	V
		$T_A = -40^\circ\text{C}$ to 85°C SOT-23 package	1.6		5.5	V
		$T_A = -40^\circ\text{C}$ to 85°C SC70 package	1		5.5	V
I_{CC}	Supply Current	MIC809L/M/J, MIC810L/M/J SOT-23 Package		9	15	μA
		For SC-70 Package: MIC809L/M/J, MIC810L/M/J		5	15	μA
		$V_{CC} < 3.6\text{V}$, MIC809R/S/T, MIC810R/S/T SOT-23 package		6	10	μA
		For SC-70 Package: $V_{CC} < 3.6\text{V}$, MIC809R/S/T, MIC810R/S/T		5	10	μA
V_{TH}	Reset Voltage Threshold	MIC809L, MIC810L	4.50	4.63	4.75	V
		MIC809M, MIC810M	4.25	4.38	4.50	V
		MIC809J, MIC810J	3.89	4.00	4.10	V
		MIC809T, MIC810T	3.00	3.08	3.15	V
		MIC809S, MIC810S	2.85	2.93	3.00	V
		MIC809R, MIC810R	2.55	2.63	2.70	V
t_{RST}	Reset Timeout Period		140	240	560	ms
V_{OH}	/RESET Output Voltage MIC809	$I_{SOURCE} = 800\mu\text{A}$, MIC809L/M/J	$V_{CC} - 1.5\text{V}$			V
		$I_{SOURCE} = 500\mu\text{A}$, MIC809R/S/T	$0.8 \times V_{CC}$			V
V_{OL}	/RESET Output Voltage MIC809	$V_{CC} = V_{TH}$ min., $I_{SINK} = 3.2\text{mA}$, MIC809L/M/J			0.4	V
		$V_{CC} = V_{TH}$ min., $I_{SINK} = 1.2\text{mA}$, MIC809R/S/T			0.3	V
		$V_{CC} > 1.4\text{V}$, $I_{SINK} = 50\mu\text{A}$, $T_A = 0^\circ\text{C}$ to $+70^\circ\text{C}$			0.3	V
		For SC-70 Package: $V_{CC} = 1\text{V}$, $I_{SINK} = 50\mu\text{A}$ $T_A = -40^\circ\text{C}$ to 85°C			0.3	V
		$V_{CC} > 1.6\text{V}$, $I_{SINK} = 50\mu\text{A}$, $T_A = -40^\circ$ to $+85^\circ\text{C}$			0.3	V
V_{OH}	RESET Output Voltage MIC810	$1.8\text{V} < V_{CC} < V_{TH}$ min., $I_{SOURCE} = 150\mu\text{A}$	$0.8 \times V_{CC}$			V
V_{OL}	RESET Output Voltage MIC810	$I_{SINK} = 3.2\text{mA}$, MIC810L/M/J			0.4	V
		$I_{SINK} = 1.2\text{mA}$, MIC810R/S/T			0.3	V

Notes:

- Exceeding the absolute maximum rating may damage the device.
- The device is not guaranteed to function outside its operating rating.
- Devices are ESD sensitive. Handling precautions recommended. Human body model, 1.5k in series with 100pF.
- Specification for packaged product only.

Timing Diagram

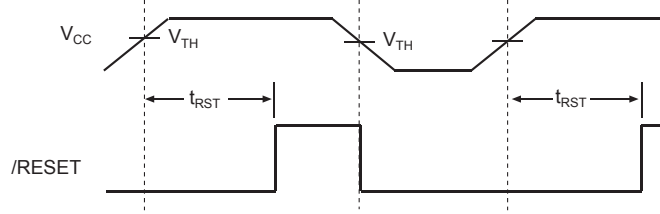

Reset Timing Diagram

Functional Diagram

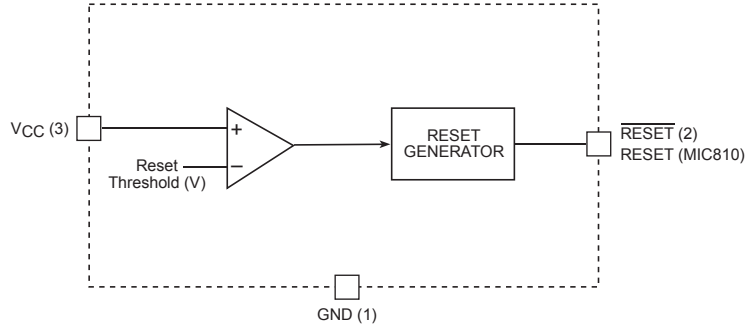

Applications Information

Microprocessor Reset

The /RESET (or RESET) pin is asserted whenever V_{CC} falls below the reset threshold voltage. The /RESET pin remains asserted for a period of 140ms after V_{CC} has risen above the reset threshold voltage. The reset function ensures the microprocessor is properly reset and powers up in a known condition after a power failure. /RESET will remain valid with V_{CC} as low as 1.4V (1V for SC-70 package).

V_{CC} Transients

The MIC809/810 are relatively immune to negative-going V_{CC} glitches below the reset threshold. Typically, a negative-going transient 125mV below the reset threshold with a duration of 20 μ s or less (SC70 package) will not cause a reset.

Interfacing to Bidirectional Reset Pins

The MIC809/810 can interface with μ Ps with bidirectional reset pins by connecting a 4.7k Ω resistor in series with the MIC809/810 output and the μ P reset pin.

/RESET Valid at Low Voltage

A resistor can be added from the /RESET pin to ground to ensure the /RESET output remains low with V_{CC} down to 0V. A 100k Ω resistor connected from the /RESET to ground is recommended. The resistor should be small enough to pull-down any stray leakage currents and large enough not to load the reset output. See Figure below.

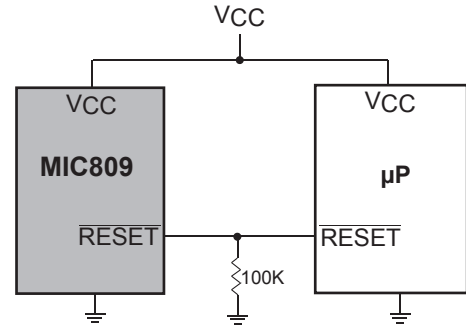

Reset Valid to $V_{CC} = 0V$

Package Information

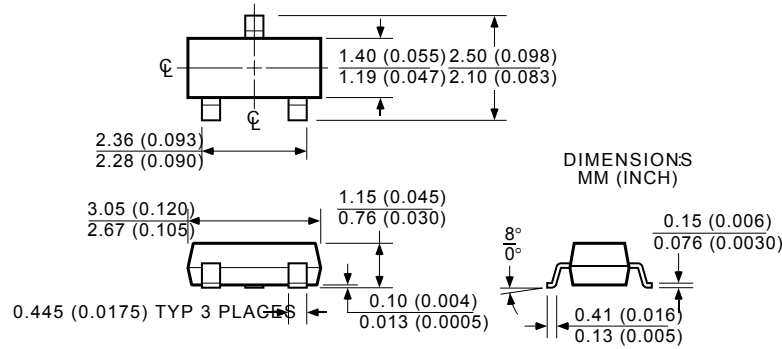

3-lead SOT-23 (M3)

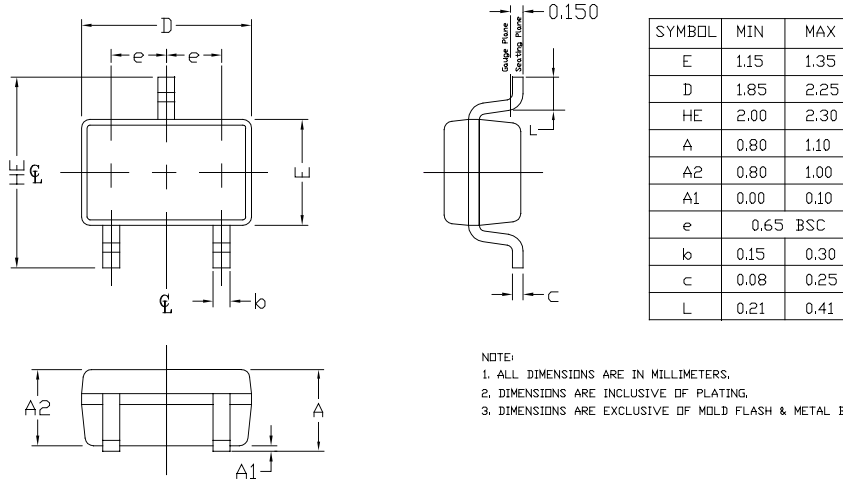

3-Lead SC-70 (C3)

MICREL, INC. 2180 FORTUNE DRIVE SAN JOSE, CA 95131 USA

TEL + 1 (408) 944-0800 FAX + 1 (408) 474-1000 WEB <http://www.micrel.com>

The information furnished by Micrel in this data sheet is believed to be accurate and reliable. However, no responsibility is assumed by Micrel for its use. Micrel reserves the right to change circuitry and specifications at any time without notification to the customer.

Micrel Products are not designed or authorized for use as components in life support appliances, devices or systems where malfunction of a product can reasonably be expected to result in personal injury. Life support devices or systems are devices or systems that (a) are intended for surgical implant into the body or (b) support or sustain life, and whose failure to perform can be reasonably expected to result in a significant injury to the user. A Purchaser's use or sale of Micrel Products for use in life support appliances, devices or systems is at Purchaser's own risk and Purchaser agrees to fully indemnify Micrel for any damages resulting from such use or sale.

© 2005 Micrel, Incorporated.