

MC9S08PT60

MC9S08PT60 Series

Support: MC9S08PT60 and
MC9S08PT32

Features

- 8-Bit S08 central processor unit (CPU)
 - Up to 20 MHz bus at 2.7 V to 5.5 V across temperature range of -40 °C to 105 °C
 - Supporting up to 40 interrupt/reset sources
 - Supporting up to four-level nested interrupt
 - On-chip memory
 - Up to 60 KB flash read/program/erase over full operating voltage and temperature
 - Up to 256 byte EEPROM; 2-byte erase sector; program and erase while executing flash
 - Up to 4096 byte random-access memory (RAM)
 - Flash and RAM access protection
- Power-saving modes
 - One low-power stop mode; reduced power wait mode
 - Peripheral clock enable register can disable clocks to unused modules, reducing currents; allows clocks to remain enabled to specific peripherals in stop3 mode
- Clocks
 - Oscillator (XOSC) - loop-controlled Pierce oscillator; crystal or ceramic resonator range of 31.25 kHz to 39.0625 kHz or 4 MHz to 20 MHz
 - Internal clock source (ICS) - containing a frequency-locked-loop (FLL) controlled by internal or external reference; precision trimming of internal reference allowing 1% deviation across temperature range of 0 °C to 70 °C and 2% deviation across temperature range of -40 °C to 105 °C; up to 20 MHz
- System protection
 - Watchdog with independent clock source
 - Low-voltage detection with reset or interrupt; selectable trip points
 - Illegal opcode detection with reset
 - Illegal address detection with reset
- Development support
 - Single-wire background debug interface
 - Breakpoint capability to allow three breakpoints setting during in-circuit debugging
 - On-chip in-circuit emulator (ICE) debug module containing two comparators and nine trigger modes
- Peripherals
 - ACMP - one analog comparator with both positive and negative inputs; separately selectable interrupt on rising and falling comparator output; filtering
 - ADC - 16-channel, 12-bit resolution; 2.5 μs conversion time; data buffers with optional watermark; automatic compare function; internal bandgap reference channel; operation in stop mode; optional hardware trigger
 - CRC - programmable cyclic redundancy check module
 - FTM - three flex timer modulators modules including one 6-channel and two 2-channel ones; 16-bit counter; each channel can be configured for input capture, output compare, edge- or center-aligned PWM mode
 - IIC - One inter-integrated circuit module; up to 400 kbps; multi-master operation; programmable slave address; supporting broadcast mode and 10-bit addressing
 - MTIM - Two modulo timers with 8-bit prescaler and overflow interrupt
 - RTC - 16-bit real timer counter (RTC)
 - SCI - three serial communication interface (SCI/UART) modules optional 13-bit break; full duplex non-return to zero (NRZ); LIN extension support
 - SPI - one 8-bit and one 16-bit serial peripheral interface (SPI) modules; full-duplex or single-wire bidirectional; master or slave mode
 - TSI - supporting up to 16 external electrodes; configurable software or hardware scan trigger; fully support freescale touch sensing software library; capability to wake MCU from stop3 mode

Freescale reserves the right to change the detail specifications as may be required to permit improvements in the design of its products.

© 2011–2012 Freescale Semiconductor, Inc.



- Input/Output
 - 57 GPIOs including one output-only pin
 - Two 8-bit keyboard interrupt modules (KBI)
 - Two true open-drain output pins
 - Eight, ultra-high current sink pins supporting 20 mA source/sink current
- Package options
 - 64-pin LQFP; 64-pin QFP
 - 48-pin LQFP
 - 44-pin LQFP
 - 32-pin LQFP

Table of Contents

1	Ordering parts.....	4	5.2.2	Debug trace timing specifications.....	15
1.1	Determining valid orderable parts.....	4	5.2.3	FTM module timing.....	16
2	Part identification.....	4	5.3	Thermal specifications.....	17
2.1	Description.....	4	5.3.1	Thermal characteristics.....	17
2.2	Format.....	4	6	Peripheral operating requirements and behaviors.....	18
2.3	Fields.....	4	6.1	External oscillator (XOSC) and ICS characteristics.....	18
2.4	Example.....	5	6.2	NVM specifications.....	20
3	Parameter Classification.....	5	6.3	Analog.....	21
4	Ratings.....	5	6.3.1	ADC characteristics.....	21
4.1	Thermal handling ratings.....	5	6.3.2	Analog comparator (ACMP) electricals.....	25
4.2	Moisture handling ratings.....	6	6.4	Communication interfaces.....	25
4.3	ESD handling ratings.....	6	6.4.1	SPI switching specifications.....	25
4.4	Voltage and current operating ratings.....	6	6.5	Human-machine interfaces (HMI).....	28
5	General.....	7	6.5.1	TSI electrical specifications.....	28
5.1	Nonswitching electrical specifications.....	7	7	Dimensions.....	29
5.1.1	DC characteristics.....	7	7.1	Obtaining package dimensions.....	29
5.1.2	Supply current characteristics.....	12	8	Pinout.....	29
5.1.3	EMC performance.....	13	8.1	Signal multiplexing and pin assignments.....	29
5.2	Switching specifications.....	14	8.2	Device pin assignment.....	33
5.2.1	Control timing.....	14	9	Revision history.....	36

1 Ordering parts

1.1 Determining valid orderable parts

Valid orderable part numbers are provided on the web. To determine the orderable part numbers for this device, go to <http://www.freescale.com> and perform a part number search for the following device numbers: PT60 and PT32.

2 Part identification

2.1 Description

Part numbers for the chip have fields that identify the specific part. You can use the values of these fields to determine the specific part you have received.

2.2 Format

Part numbers for this device have the following format:

MC 9 S08 PT AA B CC

2.3 Fields

This table lists the possible values for each field in the part number (not all combinations are valid):

Field	Description	Values
MC	Qualification status	<ul style="list-style-type: none"> MC = fully qualified, general market flow
9	Memory	<ul style="list-style-type: none"> 9 = flash based
S08	Core	<ul style="list-style-type: none"> S08 = 8-bit CPU
PT	Device family	<ul style="list-style-type: none"> PT
AA	Approximate flash size in KB	<ul style="list-style-type: none"> 60 = 60 KB 32 = 32 KB
B	Temperature range (°C)	<ul style="list-style-type: none"> V = -40 to 105 C = -40 to 85

Table continues on the next page...

Field	Description	Values
CC	Package designator	<ul style="list-style-type: none"> • QH = 64-pin QFP • LH = 64-pin LQFP • LF = 48-pin LQFP • LD = 44-pin LQFP • LC = 32-pin LQFP

2.4 Example

This is an example part number:

MC9S08PT60VQH

3 Parameter Classification

The electrical parameters shown in this supplement are guaranteed by various methods. To give the customer a better understanding, the following classification is used and the parameters are tagged accordingly in the tables where appropriate:

Table 1. Parameter Classifications

P	Those parameters are guaranteed during production testing on each individual device.
C	Those parameters are achieved by the design characterization by measuring a statistically relevant sample size across process variations.
T	Those parameters are achieved by design characterization on a small sample size from typical devices under typical conditions unless otherwise noted. All values shown in the typical column are within this category.
D	Those parameters are derived mainly from simulations.

NOTE

The classification is shown in the column labeled “C” in the parameter tables where appropriate.

4 Ratings

4.1 Thermal handling ratings

Symbol	Description	Min.	Max.	Unit	Notes
T _{STG}	Storage temperature	-55	150	°C	1
T _{SDR}	Solder temperature, lead-free	—	260	°C	2

Ratings

1. Determined according to JEDEC Standard JESD22-A103, *High Temperature Storage Life*.
2. Determined according to IPC/JEDEC Standard J-STD-020, *Moisture/Reflow Sensitivity Classification for Nonhermetic Solid State Surface Mount Devices*.

4.2 Moisture handling ratings

Symbol	Description	Min.	Max.	Unit	Notes
MSL	Moisture sensitivity level	—	3	—	1

1. Determined according to IPC/JEDEC Standard J-STD-020, *Moisture/Reflow Sensitivity Classification for Nonhermetic Solid State Surface Mount Devices*.

4.3 ESD handling ratings

Symbol	Description	Min.	Max.	Unit	Notes
V_{HBM}	Electrostatic discharge voltage, human body model	-4000	+4000	V	1
V_{CDM}	Electrostatic discharge voltage, charged-device model	-500	+500	V	2
I_{LAT}	Latch-up current at ambient temperature of 105°C	-100	+100	mA	

1. Determined according to JEDEC Standard JESD22-A114, *Electrostatic Discharge (ESD) Sensitivity Testing Human Body Model (HBM)*.
2. Determined according to JEDEC Standard JESD22-C101, *Field-Induced Charged-Device Model Test Method for Electrostatic-Discharge-Withstand Thresholds of Microelectronic Components*.

4.4 Voltage and current operating ratings

Absolute maximum ratings are stress ratings only, and functional operation at the maxima is not guaranteed. Stress beyond the limits specified in below table may affect device reliability or cause permanent damage to the device. For functional operating conditions, refer to the remaining tables in this document.

This device contains circuitry protecting against damage due to high static voltage or electrical fields; however, it is advised that normal precautions be taken to avoid application of any voltages higher than maximum-rated voltages to this high-impedance circuit. Reliability of operation is enhanced if unused inputs are tied to an appropriate logic voltage level (for instance, either V_{SS} or V_{DD}) or the programmable pullup resistor associated with the pin is enabled.

Symbol	Description	Min.	Max.	Unit
V_{DD}	Supply voltage	-0.3	5.8	V
I_{DD}	Maximum current into V_{DD}	—	120	mA

Table continues on the next page...

Symbol	Description	Min.	Max.	Unit
V _{DIO}	Digital input voltage (except RESET, EXTAL, and XTAL)	-0.3	V _{DD} + 0.3	V
V _{AIO}	Analog ¹ , RESET, EXTAL, and XTAL input voltage	-0.3	V _{DD} + 0.3	V
I _D	Instantaneous maximum current single pin limit (applies to all port pins)	-25	25	mA
V _{DDA}	Analog supply voltage	V _{DD} - 0.3	V _{DD} + 0.3	V

1. Analog pins are defined as pins that do not have an associated general purpose I/O port function.

5 General

5.1 Nonswitching electrical specifications

5.1.1 DC characteristics

This section includes information about power supply requirements and I/O pin characteristics.

Table 2. DC characteristics

Symbol	C	Descriptions		Min	Typical ¹	Max	Unit
—	—	Operating voltage		2.7	—	5.5	V
V _{OH}	P	Output high voltage	All I/O pins, low-drive strength	5 V, I _{load} = -2 mA	V _{DD} - 1.5	—	V
	C			3 V, I _{load} = -0.6 mA	V _{DD} - 0.8	—	V
	P	High current drive pins, high-drive strength ²	5 V, I _{load} = -20 mA	V _{DD} - 1.5	—	V	
	C		3 V, I _{load} = -6 mA	V _{DD} - 0.8	—	V	
I _{OHT}	D	Output high current	Max total I _{OH} for all ports	5 V	—	-100	mA
				3 V	—	-60	
V _{OL}	P	Output low voltage	All I/O pins, low-drive strength	5 V, I _{load} = 2 mA	—	1.5	V
	C			3 V, I _{load} = 0.6 mA	—	0.8	V
	P	High current drive pins, high-drive strength ²	5 V, I _{load} = 20 mA	—	1.5	V	
	C		3 V, I _{load} = 6 mA	—	0.8	V	

Table continues on the next page...

Table 2. DC characteristics (continued)

Symbol	C	Descriptions		Min	Typical ¹	Max	Unit	
I _{OLT}	D	Output low current	Max total I _{OL} for all ports	5 V	—	—	100	mA
				3 V	—	—	60	
V _{IH}	P	Input high voltage	All digital inputs	V _{DD} >4.1V	0.70 × V _{DD}	—	—	V
				V _{DD} >2.7V	0.85 × V _{DD}	—	—	
V _{IL}	P	Input low voltage	All digital inputs	V _{DD} >4.1V	—	—	0.35 × V _{DD}	V
				V _{DD} >2.7V	—	—	0.30 × V _{DD}	
V _{hys}	C	Input hysteresis	All digital inputs	—	0.06 × V _{DD}	—	—	mV
I _{inI}	P	Input leakage current	All input only pins (per pin)	V _{IN} = V _{DD} or V _{SS}	—	0.1	1	μA
I _{ozI}	P	Hi-Z (off-state) leakage current	All input/output (per pin)	V _{IN} = V _{DD} or V _{SS}	—	0.1	1	μA
I _{ozTOTI}	C	Total leakage combined for all inputs and Hi-Z pins	All input only and I/O	V _{IN} = V _{DD} or V _{SS}	—	—	2	μA
R _{PU}	P	Pullup resistors	All digital inputs, when enabled (all I/O pins other than PTA5/IRQ/TCLK/RESET)	—	17.5	—	52.5	kΩ
R _{PU} ³	P	Pullup resistors	PTA5/IRQ/TCLK/RESET	—	17.5	—	52.5	kΩ
I _{IC}	D	DC injection current ^{4, 5, 6}	Single pin limit	V _{IN} < V _{SS} , V _{IN} > V _{DD}	-0.2	—	0.2	mA
			Total MCU limit, includes sum of all stressed pins		-5	—	5	
C _{In}	C	Input capacitance, all pins		—	—	—	8	pF
V _{RAM}	C	RAM retention voltage		—	2.0	—	—	V

1. Typical values are measured at 25 °C. Characterized, not tested.
2. Only PTB4, PTB5, PTD0, PTD1, PTE0, PTE1, PTH0, and PTH1 support ultra high current output.
3. The specified resistor value is the actual value internal to the device. The pullup value may appear higher when measured externally on the pin.
4. All functional non-supply pins, except for PTA5, are internally clamped to V_{SS} and V_{DD}.
5. Input must be current limited to the value specified. To determine the value of the required current-limiting resistor, calculate resistance values for positive and negative clamp voltages, then use the large one.
6. Power supply must maintain regulation within operating V_{DD} range during instantaneous and operating maximum current conditions. If the positive injection current (V_{in} > V_{DD}) is higher than I_{DD}, the injection current may flow out of V_{DD} and could result in external power supply going out of regulation. Ensure that external V_{DD} load will shunt current higher than maximum injection current when the MCU is not consuming power, such as no system clock is present, or clock rate is very low (which would reduce overall power consumption).

Table 3. LVD and POR Specification

Symbol	C	Description	Min	Typ	Max	Unit	
V _{POR}	D	POR re-arm voltage ¹	1.5	1.75	2.0	V	
V _{LVDH}	C	Falling low-voltage detect threshold - high range (LVDV = 1) ²	4.2	4.3	4.4	V	
V _{LVW1H}	C	Falling low-voltage warning threshold - high range	Level 1 falling (LVWV = 00)	4.3	4.4	4.5	V
V _{LVW2H}	C		Level 2 falling (LVWV = 01)	4.5	4.5	4.6	V
V _{LVW3H}	C		Level 3 falling (LVWV = 10)	4.6	4.6	4.7	V
V _{LVW4H}	C		Level 4 falling (LVWV = 11)	4.7	4.7	4.8	V
V _{HYSH}	C	High range low-voltage detect/warning hysteresis	—	100	—	mV	
V _{LVDL}	C	Falling low-voltage detect threshold - low range (LVDV = 0)	2.56	2.61	2.66	V	
V _{LVDW1L}	C	Falling low-voltage warning threshold - low range	Level 1 falling (LVWV = 00)	2.62	2.7	2.78	V
V _{LVDW2L}	C		Level 2 falling (LVWV = 01)	2.72	2.8	2.88	V
V _{LVDW3L}	C		Level 3 falling (LVWV = 10)	2.82	2.9	2.98	V
V _{LVDW4L}	C		Level 4 falling (LVWV = 11)	2.92	3.0	3.08	V
V _{HYSDL}	C	Low range low-voltage detect hysteresis	—	40	—	mV	
V _{HYSWL}	C	Low range low-voltage warning hysteresis	—	80	—	mV	
V _{BG}	P	Buffered bandgap output ³	1.14	1.16	1.18	V	

1. Maximum is highest voltage that POR is guaranteed.
2. Rising thresholds are falling threshold + hysteresis.
3. voltage Factory trimmed at V_{DD} = 5.0 V, Temp = 25 °C

Nonswitching electrical specifications

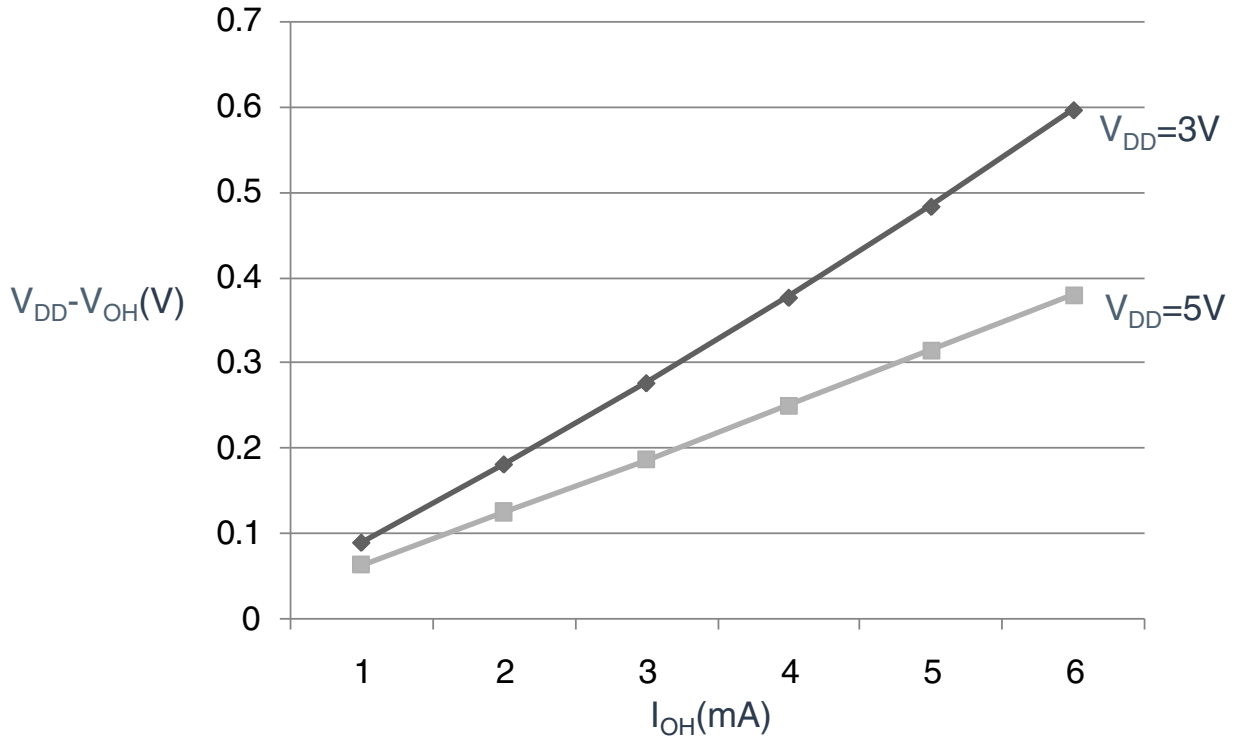

Figure 1. Typical I_{OH} Vs. $V_{DD} - V_{OH}$

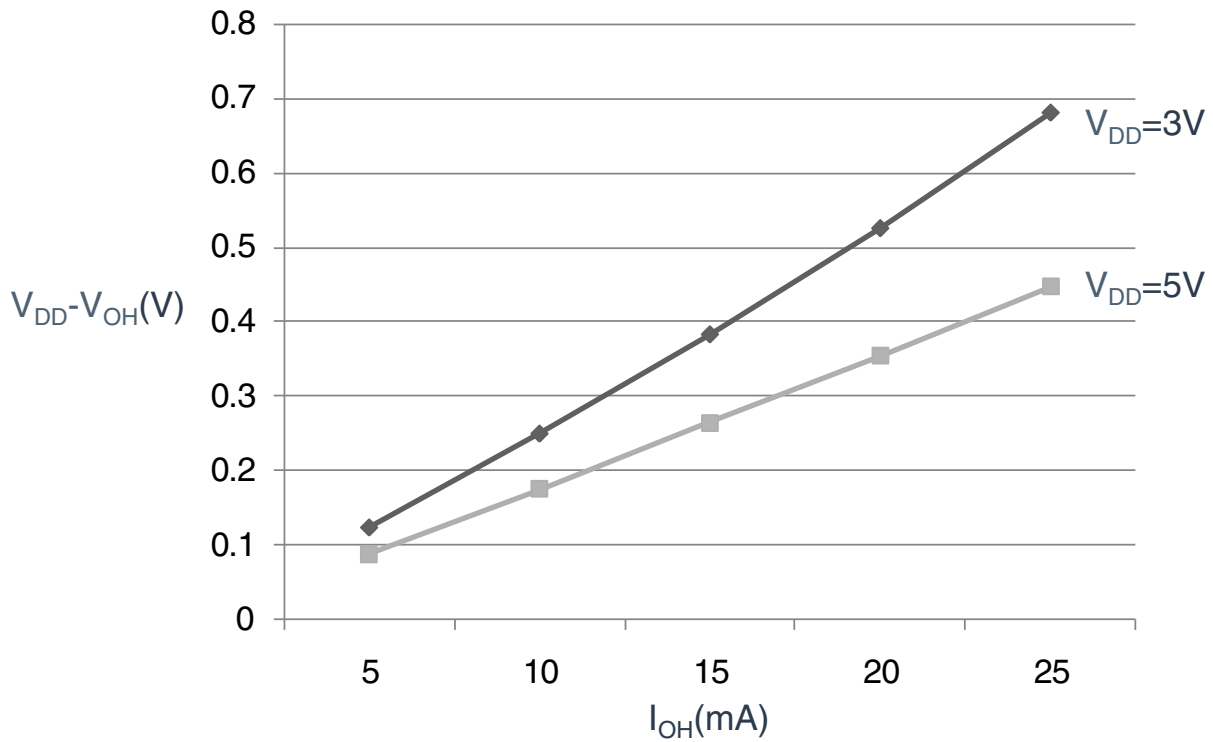

Figure 2. Typical I_{OH} Vs. $V_{DD} - V_{OH}$ (High current drive)

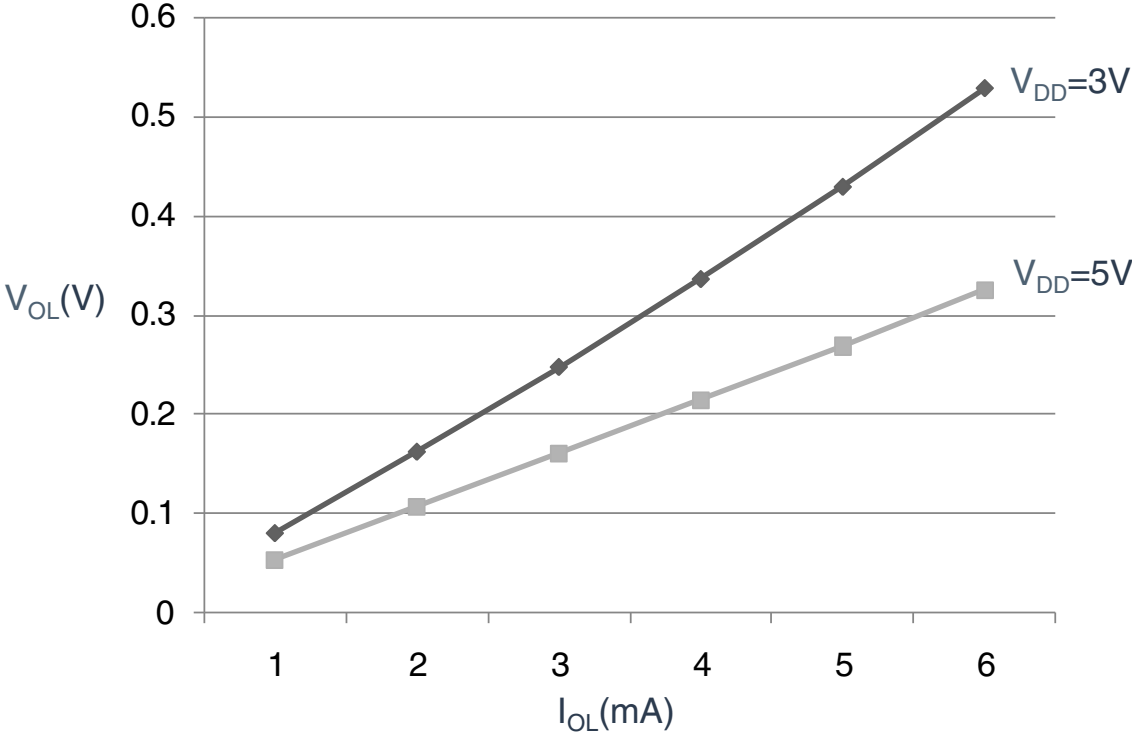

Figure 3. Typical I_{OL} Vs. V_{OL}

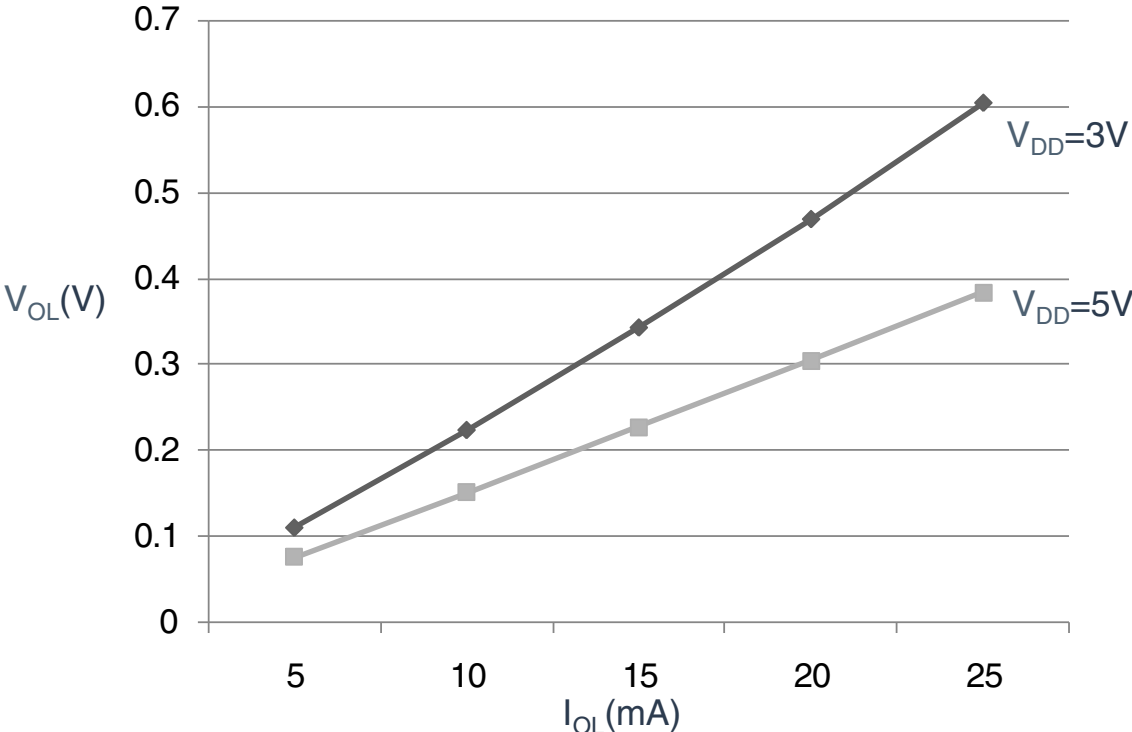

Figure 4. Typical I_{OL} Vs. V_{OL} (High current drive)

5.1.2 Supply current characteristics

This section includes information about power supply current in various operating modes.

Table 4. Supply current characteristics

Num	C	Parameter	Symbol	Bus Freq	V _{DD} (V)	Typical ¹	Max	Unit	Temp
1	C	Run supply current FEI mode, all modules on; run from flash	RI _{DD}	20 MHz	5	12.6	—	mA	-40 to 105 °C
	C			10 MHz		7.2	—		
	C			1 MHz		2.4	—		
	C			20 MHz	3	9.6	—		
	C			10 MHz		6.1	—		
	C			1 MHz		2.1	—		
2	C	Run supply current FEI mode, all modules off & gated; run from flash	RI _{DD}	20 MHz	5	10.5	—	mA	-40 to 105 °C
	C			10 MHz		6.2	—		
	C			1 MHz		2.3	—		
	C			20 MHz	3	7.4	—		
	C			10 MHz		5.0	—		
	C			1 MHz		2.0	—		
3	P	Run supply current FBE mode, all modules on; run from RAM	RI _{DD}	20 MHz	5	12.1	14.8	mA	-40 to 105 °C
	C			10 MHz		6.5	—		
	C			1 MHz		1.8	—		
	P			20 MHz	3	9.1	11.8		
	C			10 MHz		5.5	—		
	C			1 MHz		1.5	—		
4	P	Run supply current FBE mode, all modules off & gated; run from RAM	RI _{DD}	20 MHz	5	9.8	12.3	mA	-40 to 105 °C
	C			10 MHz		5.4	—		
	C			1 MHz		1.6	—		
	P			20 MHz	3	6.9	9.2		
	C			10 MHz		4.4	—		
	C			1 MHz		1.4	—		
5	C	Wait mode current FEI mode, all modules on	WI _{DD}	20 MHz	5	7.8	—	mA	-40 to 105 °C
	C			10 MHz		4.5	—		
	C			1 MHz		1.3	—		
	C			20 MHz	3	5.1	—		
	C			10 MHz		3.5	—		
	C			1 MHz		1.2	—		

Table continues on the next page...

Table 4. Supply current characteristics (continued)

Num	C	Parameter	Symbol	Bus Freq	V _{DD} (V)	Typical ¹	Max	Unit	Temp
6	C	Stop3 mode supply current no clocks active (except 1kHz LPO clock) ^{2,3}	S3I _{DD}	—	5	3.8	—	μA	-40 to 105 °C
	3				3	—	-40 to 105 °C		
7	C	ADC adder to stop3 ADLPC = 1 ADLSMP = 1 ADCO = 1 MODE = 10B ADICLK = 11B	—	—	5	44	—	μA	-40 to 105 °C
	C				3	40	—		
8	C	TSI adder to stop3 ⁴ PS = 010B NSCN = 0x0F EXTCHRG = 0 REFCHRG = 0 DVOLT = 01B	—	—	5	111	—	μA	-40 to 105 °C
	C				3	110	—		
9	C	LVD adder to stop3 ⁵	—	—	5	130	—	μA	-40 to 105 °C
	C				3	125	—		

1. Data in Typical column was characterized at 5.0 V, 25 °C or is typical recommended value.
2. RTC adder cause <1uA I_{DD} increase typically, RTC clock source is 1kHz LPO clock.
3. ACMP adder cause <1uA I_{DD} increase typically.
4. The current varies with TSI configuration and capacity of touch electrode. Please refer to [TSI electrical specifications](#).
5. LVD is periodically woken up from stop3 by 5% duty cycle. The period is equal to or less than 2 ms.

5.1.3 EMC performance

Electromagnetic compatibility (EMC) performance is highly dependant on the environment in which the MCU resides. Board design and layout, circuit topology choices, location and characteristics of external components as well as MCU software operation all play a significant role in EMC performance. The system designer should consult Freescale applications notes such as AN2321, AN1050, AN1263, AN2764, and AN1259 for advice and guidance specifically targeted at optimizing EMC performance.

5.2 Switching specifications

5.2.1 Control timing

Table 5. Control timing

Num	C	Rating	Symbol	Min	Typical ¹	Max	Unit	
1	P	Bus frequency ($t_{cyc} = 1/f_{Bus}$)	f_{Bus}	DC	—	20	MHz	
2	P	Internal low power oscillator frequency	f_{LPO}	0.67	1.0	1.25	KHz	
3	D	External reset pulse width ²	t_{extrst}	$1.5 \times t_{Self_reset}$	—	—	ns	
4	D	Reset low drive	t_{rstdrv}	$34 \times t_{cyc}$	—	—	ns	
5	D	BKGD/MS setup time after issuing background debug force reset to enter user or BDM modes	t_{MSSU}	500	—	—	ns	
6	D	BKGD/MS hold time after issuing background debug force reset to enter user or BDM modes ³	t_{MSH}	100	—	—	ns	
7	D	IRQ pulse width	Asynchronous path ²	t_{LIH}	100	—	—	ns
	D		Synchronous path ⁴	t_{IHIL}	$1.5 \times t_{cyc}$	—	—	ns
8	D	Keyboard interrupt pulse width	Asynchronous path ²	t_{LIH}	100	—	—	ns
	D		Synchronous path	t_{IHIL}	$1.5 \times t_{cyc}$	—	—	ns
9	C	Port rise and fall time - Normal drive strength (HDRVE_PTXx = 0) (load = 50 pF) ⁵	—	t_{Rise}	—	10.2	—	ns
	C		—	t_{Fall}	—	9.5	—	ns
	C	Port rise and fall time - Extreme high drive strength (HDRVE_PTXx = 1) (load = 50 pF) ⁵	—	t_{Rise}	—	5.4	—	ns
	C		—	t_{Fall}	—	4.6	—	ns

1. Typical values are based on characterization data at $V_{DD} = 5.0$ V, 25 °C unless otherwise stated.
2. This is the shortest pulse that is guaranteed to be recognized as a reset pin request.
3. To enter BDM mode following a POR, BKGD/MS must be held low during the powerup and for a hold time of t_{MSH} after V_{DD} rises above V_{LVD} .
4. This is the minimum pulse width that is guaranteed to pass through the pin synchronization circuitry. Shorter pulses may or may not be recognized. In stop mode, the synchronizer is bypassed so shorter pulses can be recognized.
5. Timing is shown with respect to 20% V_{DD} and 80% V_{DD} levels. Temperature range -40 °C to 105 °C.

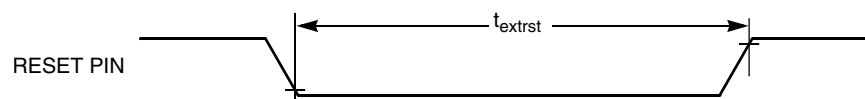

Figure 5. Reset timing

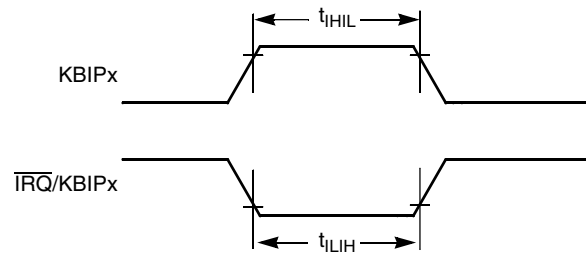

Figure 6. IRQ/KBIPx timing

5.2.2 Debug trace timing specifications

Table 6. Debug trace operating behaviors

Symbol	Description	Min.	Max.	Unit
t_{cyc}	Clock period	Frequency dependent		MHz
t_{wl}	Low pulse width	2	—	ns
t_{wh}	High pulse width	2	—	ns
t_{r}	Clock and data rise time	—	3	ns
t_{f}	Clock and data fall time	—	3	ns
t_{s}	Data setup	3	—	ns
t_{h}	Data hold	2	—	ns

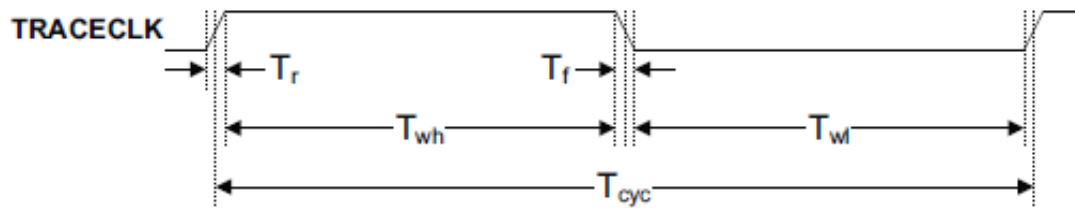

Figure 7. TRACE_CLKOUT specifications

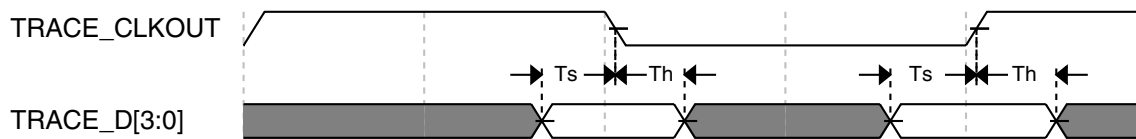

Figure 8. Trace data specifications

5.2.3 FTM module timing

Synchronizer circuits determine the shortest input pulses that can be recognized or the fastest clock that can be used as the optional external source to the timer counter. These synchronizers operate from the current bus rate clock.

Table 7. FTM input timing

No.	C	Function	Symbol	Min	Max	Unit
1	D	External clock frequency	f_{TCLK}	0	$f_{Bus}/4$	Hz
2	D	External clock period	t_{TCLK}	4	—	t_{cyc}
3	D	External clock high time	t_{clkh}	1.5	—	t_{cyc}
4	D	External clock low time	t_{clkl}	1.5	—	t_{cyc}
5	D	Input capture pulse width	t_{iCPW}	1.5	—	t_{cyc}

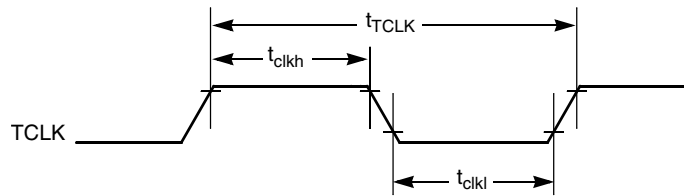

Figure 9. Timer external clock

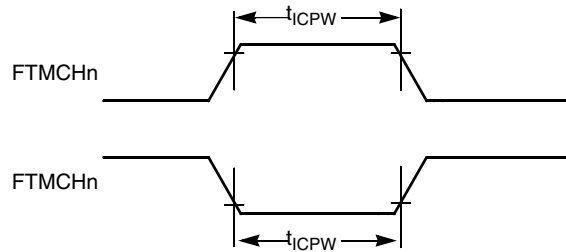

Figure 10. Timer input capture pulse

5.3 Thermal specifications

5.3.1 Thermal characteristics

This section provides information about operating temperature range, power dissipation, and package thermal resistance. Power dissipation on I/O pins is usually small compared to the power dissipation in on-chip logic and voltage regulator circuits, and it is user-determined rather than being controlled by the MCU design. To take $P_{I/O}$ into account in power calculations, determine the difference between actual pin voltage and V_{SS} or V_{DD} and multiply by the pin current for each I/O pin. Except in cases of unusually high pin current (heavy loads), the difference between pin voltage and V_{SS} or V_{DD} will be very small.

Table 8. Thermal characteristics

Rating	Symbol	Value	Unit
Operating temperature range (packaged)	T_A	-40 to 105	°C
Junction temperature range	T_J	-40 to 150	°C
Thermal resistance single-layer board			
64-pin LQFP	θ_{JA}	71	°C/W
64-pin QFP	θ_{JA}	61	°C/W
48-pin LQFP	θ_{JA}	81	°C/W
44-pin LQFP	θ_{JA}	75	°C/W
32-pin LQFP	θ_{JA}	86	°C/W
Thermal resistance four-layer board			
64-pin LQFP	θ_{JA}	53	°C/W
64-pin QFP	θ_{JA}	47	°C/W
48-pin LQFP	θ_{JA}	57	°C/W
44-pin LQFP	θ_{JA}	53	°C/W
32-pin LQFP	θ_{JA}	57	°C/W

The average chip-junction temperature (T_J) in °C can be obtained from:

$$T_J = T_A + (P_D \times \theta_{JA})$$

Where:

T_A = Ambient temperature, °C

Peripheral operating requirements and behaviors

θ_{JA} = Package thermal resistance, junction-to-ambient, °C/W

$$P_D = P_{int} + P_{I/O}$$

$P_{int} = I_{DD} \times V_{DD}$, Watts - chip internal power

$P_{I/O}$ = Power dissipation on input and output pins - user determined

For most applications, $P_{I/O} \ll P_{int}$ and can be neglected. An approximate relationship between P_D and T_J (if $P_{I/O}$ is neglected) is:

$$P_D = K \div (T_J + 273 \text{ }^\circ\text{C})$$

Solving the equations above for K gives:

$$K = P_D \times (T_A + 273 \text{ }^\circ\text{C}) + \theta_{JA} \times (P_D)^2$$

where K is a constant pertaining to the particular part. K can be determined by measuring P_D (at equilibrium) for a known T_A . Using this value of K, the values of P_D and T_J can be obtained by solving the above equations iteratively for any value of T_A .

6 Peripheral operating requirements and behaviors

6.1 External oscillator (XOSC) and ICS characteristics

Table 9. XOSC and ICS specifications (temperature range = -40 to 105 °C ambient)

Num	C	Characteristic	Symbol	Min	Typical ¹	Max	Unit	
1	C	Oscillator crystal or resonator	Low range (RANGE = 0)	f_{lo}	32	—	40	kHz
	C		High range (RANGE = 1) FEE or FBE mode ²	f_{hi}	4	—	20	MHz
	C		High range (RANGE = 1), high gain (HGO = 1), FBELP mode	f_{hi}	4	—	20	MHz
	C		High range (RANGE = 1), low power (HGO = 0), FBELP mode	f_{hi}	4	—	20	MHz
2	D	Load capacitors	C1, C2	See Note ³				

Table continues on the next page...

**Table 9. XOSC and ICS specifications (temperature range = -40 to 105 °C ambient)
(continued)**

Num	C	Characteristic		Symbol	Min	Typical ¹	Max	Unit
3	D	Feedback resistor	Low Frequency, Low-Power Mode ⁴	R_F	—	—	—	MΩ
			Low Frequency, High-Gain Mode		—	10	—	MΩ
			High Frequency, Low-Power Mode		—	1	—	MΩ
			High Frequency, High-Gain Mode		—	1	—	MΩ
4	D	Series resistor - Low Frequency	Low-Power Mode ⁴	R_S	—	—	—	kΩ
			High-Gain Mode		—	200	—	kΩ
5	D	Series resistor - High Frequency	Low-Power Mode ⁴	R_S	—	—	—	kΩ
	D	Series resistor - High Frequency, High-Gain Mode	1 MHz		—	6.6	—	kΩ
	D		2 MHz		—	3.3	—	kΩ
	D		4 MHz		—	0	—	kΩ
	D		8 MHz		—	0	—	kΩ
	D		16 MHz		—	0	—	kΩ
6	C	Crystal start-up time Low range = 32.768 KHz crystal; High range = 20 MHz crystal ^{5, 6}	Low range, low power	t_{CSTL}	—	1000	—	ms
	Low range, high power		—		800	—	ms	
	C		High range, low power	t_{CSTH}	—	3	—	ms
	C		High range, high power		—	1.5	—	ms
7	T	Internal reference start-up time		t_{IRST}	—	20	50	μs
8	D	Square wave input clock frequency	FEE or FBE mode ²	f_{extal}	0.03125	—	5	MHz
	D		FBELP mode		0	—	20	MHz
9	P	Average internal reference frequency - trimmed		f_{int_t}	—	32.768	—	kHz
10	P	DCO output frequency range - trimmed		f_{dco_t}	16	—	20	MHz
11	P	Total deviation of DCO output from trimmed frequency ⁵	Over full voltage and temperature range	Δf_{dco_t}	—	—	±2.0	% f_{dco}
	C		Over fixed voltage and temperature range of 0 to 70 °C				±1.0	
12	C	FLL acquisition time ^{5, 7}		$t_{Acquire}$	—	—	2	ms
13	C	Long term jitter of DCO output clock (averaged over 2 ms interval) ⁸		C_{Jitter}	—	0.02	0.2	% f_{dco}

1. Data in Typical column was characterized at 5.0 V, 25 °C or is typical recommended value.

2. When ICS is configured for FEE or FBE mode, input clock source must be divisible using RDIV to within the range of 31.25 kHz to 39.0625 kHz.

3. See crystal or resonator manufacturer's recommendation.

Peripheral operating requirements and behaviors

4. Load capacitors (C_1, C_2), feedback resistor (R_F) and series resistor (R_S) are incorporated internally when $RANGE = HGO = 0$.
5. This parameter is characterized and not tested on each device.
6. Proper PC board layout procedures must be followed to achieve specifications.
7. This specification applies to any time the FLL reference source or reference divider is changed, trim value changed, DMX32 bit is changed, DRS bit is changed, or changing from FLL disabled (FBELP, FBILP) to FLL enabled (FEI, FEE, FBE, FBI). If a crystal/resonator is being used as the reference, this specification assumes it is already running.
8. Jitter is the average deviation from the programmed frequency measured over the specified interval at maximum f_{Bus} . Measurements are made with the device powered by filtered supplies and clocked by a stable external clock signal. Noise injected into the FLL circuitry via V_{DD} and V_{SS} and variation in crystal oscillator frequency increase the C_{Jitter} percentage for a given interval.

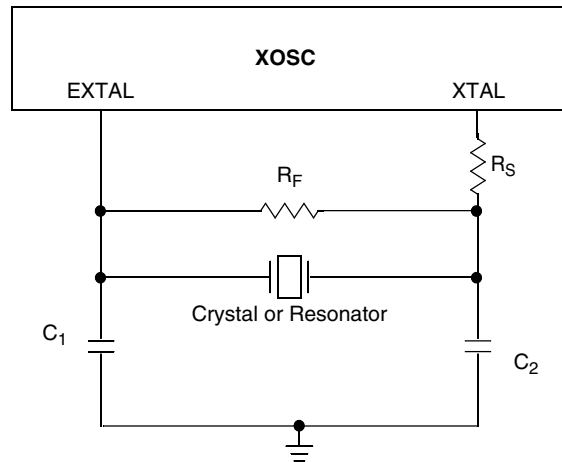

Figure 11. Typical crystal or resonator circuit

6.2 NVM specifications

This section provides details about program/erase times and program-erase endurance for the flash and EEPROM memories.

Table 10. Flash characteristics

C	Characteristic	Symbol	Min ¹	Typical ²	Max ³	Unit ⁴
D	Supply voltage for program/erase -40 °C to 105 °C	$V_{prog/erase}$	2.7	—	5.5	V
D	Supply voltage for read operation	V_{Read}	2.7	—	5.5	V
D	NVM Bus frequency	f_{NVMBUS}	1	—	25	MHz
D	NVM Operating frequency	f_{NVMOP}	0.8	—	1.05	MHz
D	Erase Verify All Blocks	t_{VFYALL}	—	—	17030	t_{cyc}
D	Erase Verify Flash Block	t_{RD1BLK}	—	—	16977	t_{cyc}
D	Erase Verify EEPROM Block	t_{RD1BLK}	—	—	843	t_{cyc}
D	Erase Verify Flash Section	t_{RD1SEC}	—	—	517	t_{cyc}
D	Erase Verify EEPROM Section	$t_{DRD1SEC}$	0.10	0.10	0.11	ms

Table continues on the next page...

Table 10. Flash characteristics (continued)

C	Characteristic	Symbol	Min ¹	Typical ²	Max ³	Unit ⁴
D	Read Once	t _{RDONCE}	—	—	455	t _{cyc}
D	Program Flash (2 word)	t _{PGM2}	0.12	0.12	0.14	ms
D	Program Flash (4 word)	t _{PGM4}	0.20	0.21	0.24	ms
D	Program Once	t _{PGMONCE}	0.20	0.21	0.24	ms
D	Program EEPROM (1 Byte)	t _{DPGM1}	0.02	0.02	0.02	ms
D	Program EEPROM (2 Byte)	t _{DPGM2}	0.17	0.18	0.20	ms
D	Erase All Blocks	t _{ERSALL}	96.01	100.78	125.80	ms
D	Erase Flash Block	t _{ERSBLK}	95.98	100.75	125.76	ms
D	Erase Flash Sector	t _{ERSPG}	19.10	20.05	25.05	ms
D	Erase EEPROM Sector	t _{DERSPG}	4.81	5.05	6.30	ms
D	Unsecure Flash	t _{UNSECU}	96.01	100.78	125.80	ms
D	Verify Backdoor Access Key	t _{VFYKEY}	—	—	469	t _{cyc}
D	Set User Margin Level	t _{MLOADU}	—	—	442	t _{cyc}
C	FLASH Program/erase endurance T _L to T _H = -40 °C to 105 °C	n _{FLPE}	10 k	100 k	—	Cycles
C	EEPROM Program/erase endurance TL to TH = -40 °C to 105 °C	n _{FLPE}	50 k	500 k	—	Cycles
C	Data retention at an average junction temperature of T _{Javg} = 85°C after up to 10,000 program/erase cycles	t _{D_ret}	15	100	—	years

1. Minimum times are based on maximum f_{NVMOP} and maximum f_{NVMBUS}
2. Typical times are based on typical f_{NVMOP} and maximum f_{NVMBUS}
3. Maximum times are based on minimum f_{NVMOP} and maximum f_{NVMBUS}
4. t_{cyc} = 1 / f_{NVMBUS}

Program and erase operations do not require any special power sources other than the normal V_{DD} supply. For more detailed information about program/erase operations, see the Memory section.

6.3 Analog

6.3.1 ADC characteristics

Table 11. 5 V 12-bit ADC operating conditions

Characteristic	Conditions	Symb	Min	Typ ¹	Max	Unit	Comment			
Supply voltage	Absolute	V_{DDA}	2.7	—	5.5	V	—			
	Delta to V_{DD} ($V_{DD}-V_{DDAD}$)	ΔV_{DDA}	-100	0	+100	mV				
Ground voltage	Delta to V_{SS} ($V_{SS}-V_{SSA}$) ³	ΔV_{SSA}	-100	0	+100	mV				
Input voltage		V_{ADIN}	V_{REFL}	—	V_{REFH}	V	—			
Input capacitance		C_{ADIN}	—	4.5	5.5	pF	—			
Input resistance		R_{ADIN}	—	3	5	k Ω	—			
Analog source resistance	12-bit mode	R_{AS}				k Ω	External to MCU			
	$f_{ADCK} > 4$ MHz							—	—	2
	$f_{ADCK} < 4$ MHz							—	—	5
	10-bit mode									
$f_{ADCK} > 4$ MHz	—	—	5							
$f_{ADCK} < 4$ MHz	—	—	10							
8-bit mode (all valid f_{ADCK})					10					
ADC conversion clock frequency	High Speed (ADLPC=0)	f_{ADCK}	0.4	—	8.0	MHz	—			
	Low Power (ADLPC=1)		0.4	—	4.0					

1. Typical values assume $V_{DDA} = 5.0$ V, Temp = 25°C, $f_{ADCK}=1.0$ MHz unless otherwise stated. Typical values are for reference only and are not tested in production.
2. DC potential difference.

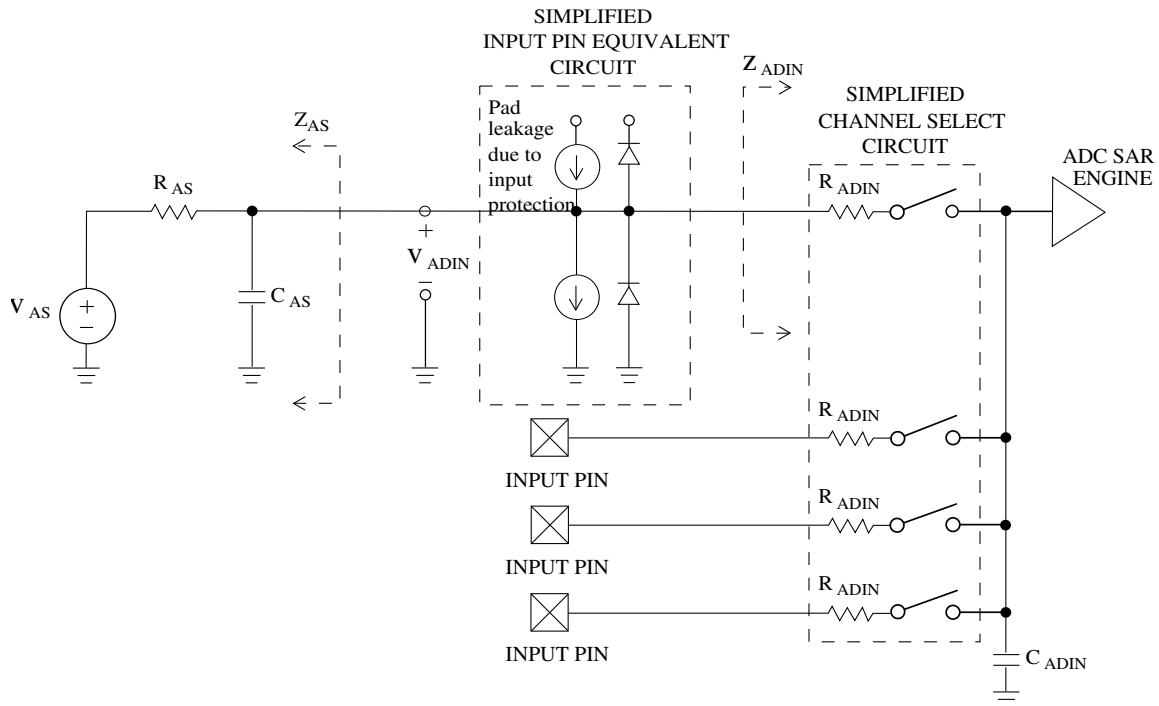

Figure 12. ADC input impedance equivalency diagram

Table 12. 12-bit ADC Characteristics ($V_{REFH} = V_{DDA}$, $V_{REFL} = V_{SSA}$)

Characteristic	Conditions	C	Symb	Min	Typ ¹	Max	Unit	Comment
Supply current ADLPC = 1 ADLSMP = 1 ADCO = 1		T	I_{DDA}	—	133	—	μA	—
Supply current ADLPC = 1 ADLSMP = 0 ADCO = 1		T	I_{DDA}	—	218	—	μA	—
Supply current ADLPC = 0 ADLSMP = 1 ADCO = 1		T	I_{DDA}	—	327	—	μA	—
Supply current ADLPC = 0 ADLSMP = 0 ADCO = 1		T	I_{DDAD}	—	582	990	μA	—
Supply current	Stop, reset, module off	T	I_{DDA}	—	0.011	1	μA	

Table continues on the next page...

Table 12. 12-bit ADC Characteristics ($V_{REFH} = V_{DDA}$, $V_{REFL} = V_{SSA}$) (continued)

Characteristic	Conditions	C	Symb	Min	Typ ¹	Max	Unit	Comment
ADC asynchronous clock source	High speed (ADLPC = 0)	P	f_{ADACK}	2	3.3	5	MHz	$t_{ADACK} = 1/f_{ADACK}$
	Low power (ADLPC = 1)			1.25	2	3.3		
Conversion time (including sample time)	Short sample (ADLSMP = 0)	T	t_{ADC}	—	20	—	ADCK cycles	—
	Long sample (ADLSMP = 1)			—	40	—		
Sample time	Short sample (ADLSMP = 0)	T	t_{ADS}	—	3.5	—	ADCK cycles	—
	Long sample (ADLSMP = 1)			—	23.5	—		
Total unadjusted Error	12-bit mode	T	E_{TUE}	—	± 5.0	—	LSB ²	Includes quantization
	10-bit mode	P		—	± 1.5	± 2.0		
	8-bit mode	P		—	± 0.7	± 1.0		
Differential Non-Linearity	12-bit mode	T	DNL	—	± 1.0	—	LSB ²	—
	10-bit mode ³	P		—	± 0.25	± 0.5		
	8-bit mode ³	P		—	± 0.15	± 0.25		
Integral Non-Linearity	12-bit mode	T	INL	—	± 1.0	—	LSB ²	—
	10-bit mode	T		—	± 0.3	± 0.5		
	8-bit mode	T		—	± 0.15	± 0.25		
Zero-scale error	12-bit mode	C	E_{ZS}	—	± 2.0	—	LSB ²	$V_{ADIN} = V_{SSA}$
	10-bit mode	P		—	± 0.25	± 1.0		
	8-bit mode	P		—	± 0.65	± 1.0		
Full-scale error	12-bit mode	T	E_{FS}	—	± 2.5	—	LSB ²	$V_{ADIN} = V_{DDA}$
	10-bit mode	T		—	± 0.5	± 1.0		
	8-bit mode	T		—	± 0.5	± 1.0		
Quantization error	≤ 12 bit modes	D	E_Q	—	—	± 0.5	LSB ²	—
Input leakage error	all modes	D	E_{IL}	$I_{in} * R_{AS}$			mV	I_{in} = leakage current (refer to DC characteristics)
Temp sensor slope	-40°C– 25°C	D	m	—	3.266	—	mV/°C	—
	25°C– 125°C			—	3.638	—		
Temp sensor voltage	25°C	D	V_{TEMP25}	—	1.396	—	V	—

1. Typical values assume $V_{DDA} = 5.0$ V, Temp = 25°C, $f_{ADCK} = 1.0$ MHz unless otherwise stated. Typical values are for reference only and are not tested in production.
2. $1 \text{ LSB} = (V_{REFH} - V_{REFL})/2^N$

3. Monotonicity and no-missing-codes guaranteed in 10-bit and 8-bit modes

6.3.2 Analog comparator (ACMP) electricals

Table 13. Comparator electrical specifications

C	Characteristic	Symbol	Min	Typical	Max	Unit
D	Supply voltage	V_{DDA}	2.7	—	5.5	V
T	Supply current (Operation mode)	I_{DDA}	—	10	20	μA
D	Analog input voltage	V_{AIN}	$V_{SS} - 0.3$	—	V_{DDA}	V
P	Analog input offset voltage	V_{AIO}	—	—	40	mV
C	Analog comparator hysteresis (HYST=0)	V_H	—	15	20	mV
C	Analog comparator hysteresis (HYST=1)	V_H	—	20	30	mV
T	Supply current (Off mode)	$I_{DDA\text{OFF}}$	—	60	—	nA
C	Propagation Delay	t_D	—	0.4	1	μs

6.4 Communication interfaces

6.4.1 SPI switching specifications

The serial peripheral interface (SPI) provides a synchronous serial bus with master and slave operations. Many of the transfer attributes are programmable. The following tables provide timing characteristics for classic SPI timing modes. Refer to the SPI chapter of the chip's reference manual for information about the modified transfer formats used for communicating with slower peripheral devices. All timing is shown with respect to 20% V_{DD} and 70% V_{DD} , unless noted, and 100 pF load on all SPI pins. All timing assumes slew rate control is disabled and high drive strength is enabled for SPI output pins.

Table 14. SPI master mode timing

Nu m.	Symbol	Description	Min.	Max.	Unit	Comment
1	f_{op}	Frequency of operation	$f_{BUS}/2048$	$f_{BUS}/2$	Hz	f_{BUS} is the bus clock
2	t_{SPSCK}	SPSCK period	$2 \times t_{BUS}$	$2048 \times t_{BUS}$	ns	$t_{BUS} = 1/f_{BUS}$
3	t_{Lead}	Enable lead time	1/2	—	t_{SPSCK}	—
4	t_{Lag}	Enable lag time	1/2	—	t_{SPSCK}	—
5	t_{WSPSCK}	Clock (SPSCK) high or low time	$t_{BUS} - 30$	$1024 \times t_{BUS}$	ns	—

Table continues on the next page...

Table 14. SPI master mode timing (continued)

Nu m.	Symbol	Description	Min.	Max.	Unit	Comment
6	t_{SU}	Data setup time (inputs)	15	—	ns	—
7	t_{HI}	Data hold time (inputs)	0	—	ns	—
8	t_v	Data valid (after SPSCCK edge)	—	25	ns	—
9	t_{HO}	Data hold time (outputs)	0	—	ns	—
10	t_{RI}	Rise time input	—	$t_{Bus} - 25$	ns	—
	t_{FI}	Fall time input				
11	t_{RO}	Rise time output	—	25	ns	—
	t_{FO}	Fall time output				

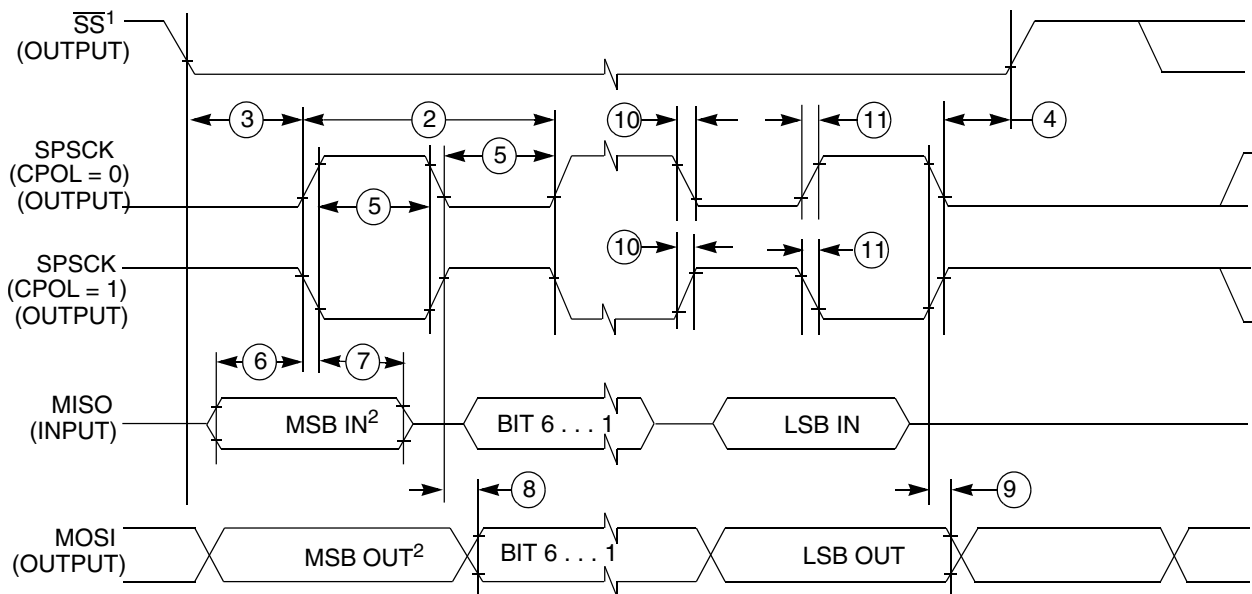

- 1. If configured as an output.
- 2. LSBF = 0. For LSBF = 1, bit order is LSB, bit 1, ..., bit 6, MSB.

Figure 13. SPI master mode timing (CPHA=0)

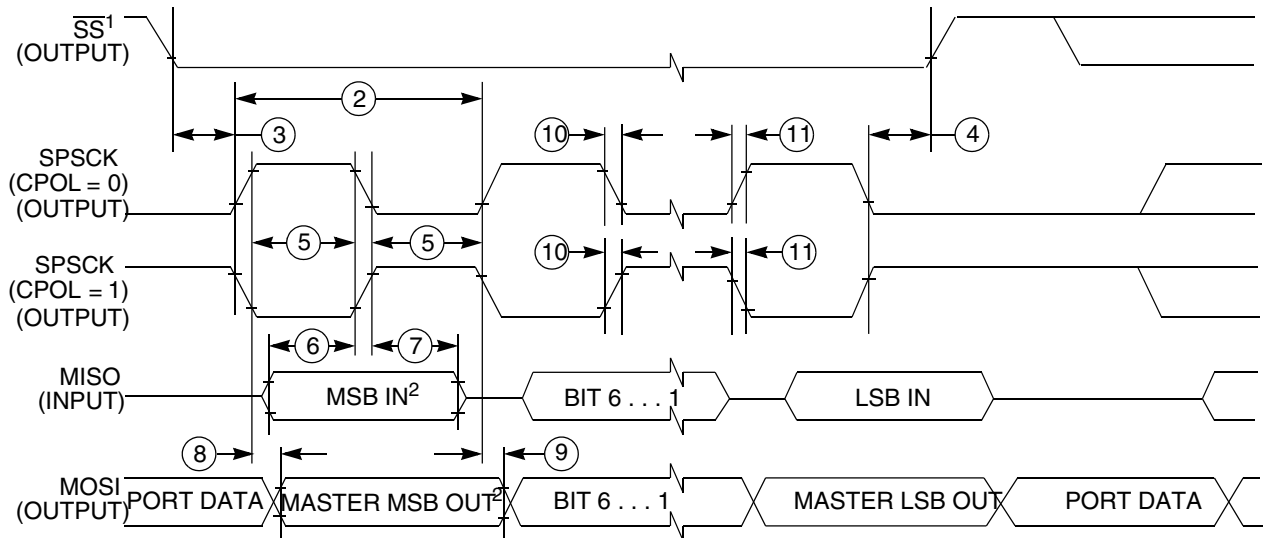

1. If configured as output

2. LSBF = 0. For LSBF = 1, bit order is LSB, bit 1, ..., bit 6, MSB.

Figure 14. SPI master mode timing (CPHA=1)

Table 15. SPI slave mode timing

Nu m.	Symbol	Description	Min.	Max.	Unit	Comment
1	f_{op}	Frequency of operation	0	$f_{Bus}/4$	Hz	f_{Bus} is the bus clock as defined in .
2	t_{SPSCCK}	SPSCCK period	$4 \times t_{Bus}$	—	ns	$t_{Bus} = 1/f_{Bus}$
3	t_{Lead}	Enable lead time	1	—	t_{Bus}	—
4	t_{Lag}	Enable lag time	1	—	t_{Bus}	—
5	$t_{WSPSCCK}$	Clock (SPSCCK) high or low time	$t_{Bus} - 30$	—	ns	—
6	t_{SU}	Data setup time (inputs)	15	—	ns	—
7	t_{HI}	Data hold time (inputs)	25	—	ns	—
8	t_a	Slave access time	—	t_{Bus}	ns	Time to data active from high-impedance state
9	t_{dis}	Slave MISO disable time	—	t_{Bus}	ns	Hold time to high-impedance state
10	t_v	Data valid (after SPSCCK edge)	—	25	ns	—
11	t_{HO}	Data hold time (outputs)	0	—	ns	—
12	t_{RI}	Rise time input	—	$t_{Bus} - 25$	ns	—
	t_{FI}	Fall time input				
13	t_{RO}	Rise time output	—	25	ns	—
	t_{FO}	Fall time output				

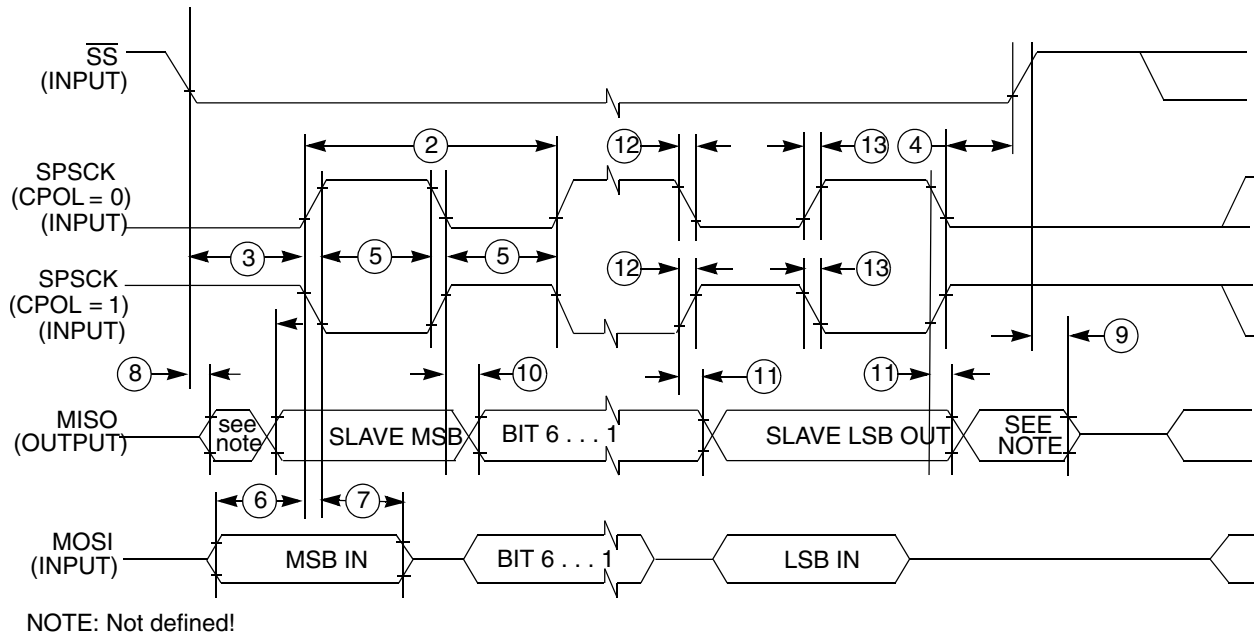

Figure 15. SPI slave mode timing (CPHA = 0)

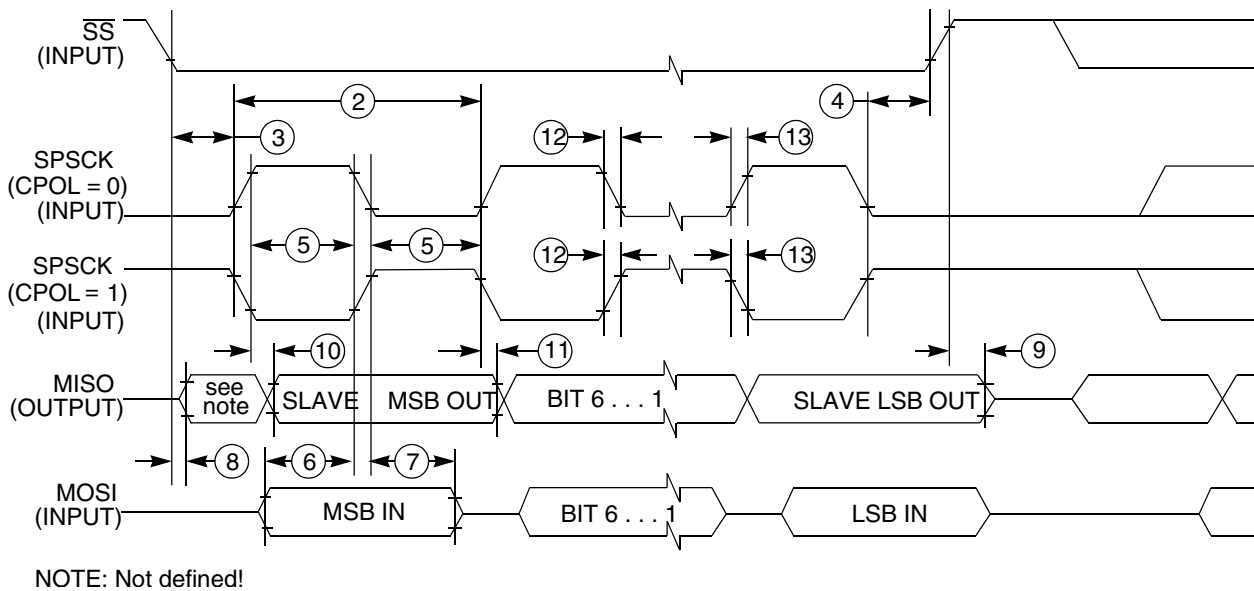

Figure 16. SPI slave mode timing (CPHA=1)

6.5 Human-machine interfaces (HMI)

6.5.1 TSI electrical specifications

Table 16. TSI electrical specifications

Symbol	Description	Min.	Type	Max	Unit
TSI_RUNF	Fixed power consumption in run mode	—	100	—	μA
TSI_RUNV	Variable power consumption in run mode (depends on oscillator's current selection)	1.0	—	128	μA
TSI_EN	Power consumption in enable mode	—	100	—	μA
TSI_DIS	Power consumption in disable mode	—	1.2	—	μA
TSI_TEN	TSI analog enable time	—	66	—	μs
TSI_CREF	TSI reference capacitor	—	1.0	—	pF
TSI_DVOLT	Voltage variation of VP & VM around nominal values	0.19	—	1.03	V

7 Dimensions

7.1 Obtaining package dimensions

Package dimensions are provided in package drawings.

To find a package drawing, go to <http://www.freescale.com> and perform a keyword search for the drawing's document number:

If you want the drawing for this package	Then use this document number
32-pin LQFP	98ASH70029A
44-pin LQFP	98ASS23225W
48-pin LQFP	98ASH00962A
64-pin QFP	98ASB42844B
64-pin LQFP	98ASS23234W

8 Pinout

8.1 Signal multiplexing and pin assignments

The following table shows the signals available on each pin and the locations of these pins on the devices supported by this document. The Port Control Module is responsible for selecting which ALT functionality is available on each pin.

Table 17. Pin availability by package pin-count

Pin Number				Lowest Priority <-- --> Highest				
64-LQFP 64-QFP	48-LQFP	44-LQFP	32-LQFP	Port Pin	Alt 1	Alt 2	Alt 3	Alt 4
1	1	1	1	PTD1 ¹	KBI1P1	FTM2CH3	MOSI1	—
2	2	2	2	PTD0 ¹	KBI1P0	FTM2CH2	SPSCK1	—
3	—	—	—	PTH7	—	—	—	—
4	—	—	—	PTH6	—	—	—	—
5	3	3	—	PTE7	—	TCLK2	—	—
6	4	4	—	PTH2	—	BUSOUT	—	—
7	5	5	3	—	—	—	—	V _{DD}
8	6	6	4	—	—	—	V _{DDA}	V _{REFH}
9	7	7	5	—	—	—	V _{SSA}	V _{REFL}
10	8	8	6	—	—	—	—	V _{SS}
11	9	9	7	PTB7	—	SCL	—	EXTAL
12	10	10	8	PTB6	—	SDA	—	XTAL
13	11	11	—	—	—	—	—	V _{SS}
14	—	—	—	PTH1 ¹	—	FTM2CH1	—	—
15	—	—	—	PTH0 ¹	—	FTM2CH0	—	—
16	12	—	—	PTE6	—	—	—	—
17	13	—	—	PTE5	—	—	—	—
18	14	12	9	PTB5 ¹	FTM2CH5	SS0	—	—
19	15	13	10	PTB4 ¹	FTM2CH4	MISO0	—	—
20	16	14	11	PTC3	FTM2CH3	—	ADP11	—
21	17	15	12	PTC2	FTM2CH2	—	ADP10	—
22	18	16	—	PTD7	KBI1P7	TXD2	—	—
23	19	17	—	PTD6	KBI1P6	RXD2	—	—
24	20	18	—	PTD5	KBI1P5	—	—	—
25	21	19	13	PTC1	—	FTM2CH1	ADP9	TSI7
26	22	20	14	PTC0	—	FTM2CH0	ADP8	TSI6
27	—	—	—	PTF7	—	—	ADP15	—
28	—	—	—	PTF6	—	—	ADP14	—
29	—	—	—	PTF5	—	—	ADP13	—
30	—	—	—	PTF4	—	—	ADP12	—
31	23	21	15	PTB3	KBI0P7	MOSI0	ADP7	TSI5
32	24	22	16	PTB2	KBI0P6	SPSCK0	ADP6	TSI4

Table continues on the next page...

Table 17. Pin availability by package pin-count (continued)

Pin Number				Lowest Priority <-- --> Highest				
64-LQFP 64-QFP	48-LQFP	44-LQFP	32-LQFP	Port Pin	Alt 1	Alt 2	Alt 3	Alt 4
33	25	23	17	PTB1	KBI0P5	TXD0	ADP5	TSI3
34	26	24	18	PTB0	KBI0P4	RXD0	ADP4	TSI2
35	—	—	—	PTF3	—	—	—	TSI15
36	—	—	—	PTF2	—	—	—	TSI14
37	27	25	19	PTA7	FTM2FAULT2	—	ADP3	TSI1
38	28	26	20	PTA6	FTM2FAULT1	—	ADP2	TSI0
39	29	—	—	PTE4	—	—	—	—
40	30	27	—	—	—	—	—	V _{SS}
41	31	28	—	—	—	—	—	V _{DD}
42	—	—	—	PTF1	—	—	—	TSI13
43	—	—	—	PTF0	—	—	—	TSI12
44	32	29	—	PTD4	KBI1P4	—	—	—
45	33	30	21	PTD3	KBI1P3	SS1	—	TSI11
46	34	31	22	PTD2	KBI1P2	MISO1	—	TSI10
47	35	32	23	PTA3 ²	KBI0P3	TXD0	SCL	—
48	36	33	24	PTA2 ²	KBI0P2	RXD0	SDA	—
49	37	34	25	PTA1	KBI0P1	FTM0CH1	ACMP1	ADP1
50	38	35	26	PTA0	KBI0P0	FTM0CH0	ACMP0	ADP0
51	39	36	27	PTC7	—	TxD1	—	TSI9
52	40	37	28	PTC6	—	RxD1	—	TSI8
53	41	—	—	PTE3	—	SS0	—	—
54	42	38	—	PTE2	—	MISO0	—	—
55	—	—	—	PTG3	—	—	—	—
56	—	—	—	PTG2	—	—	—	—
57	—	—	—	PTG1	—	—	—	—
58	—	—	—	PTG0	—	—	—	—
59	43	39	—	PTE1 ¹	—	MOSI0	—	—
60	44	40	—	PTE0 ¹	—	SPSCK0	TCLK1	—
61	45	41	29	PTC5	—	FTM1CH1	—	—
62	46	42	30	PTC4	—	FTM1CH0	RTCO	—
63	47	43	31	PTA5	IRQ	TCLK0	—	RESET
64	48	44	32	PTA4	—	ACMPO	BKGD	MS

1. This is a high current drive pin when operated as output.
2. This is a true open-drain pin when operated as output.

Note

When an alternative function is first enabled, it is possible to get a spurious edge to the module. User software must clear any associated flags before interrupts are enabled. The table above illustrates the priority if multiple modules are enabled. The highest priority module will have control over the pin. Selecting a higher priority pin function with a lower priority function already enabled can cause spurious edges to the lower priority module. Disable all modules that share a pin before enabling another module.

8.2 Device pin assignment

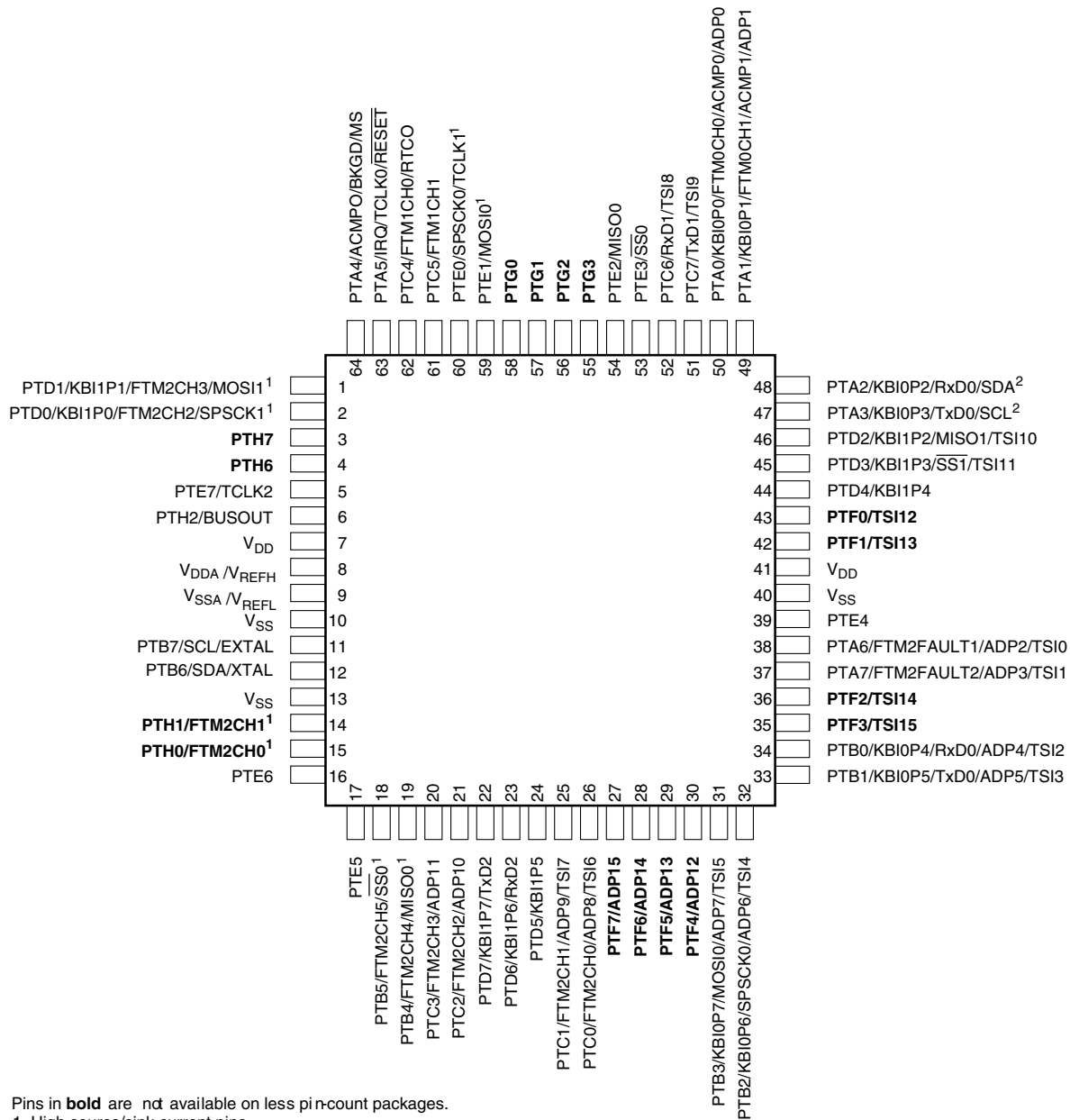

Pins in **bold** are not available on less pin-count packages.

1. High source/sink current pins

2. True open drain pins

Figure 17. MC9S08PT60 64-pin QFP and LQFP package

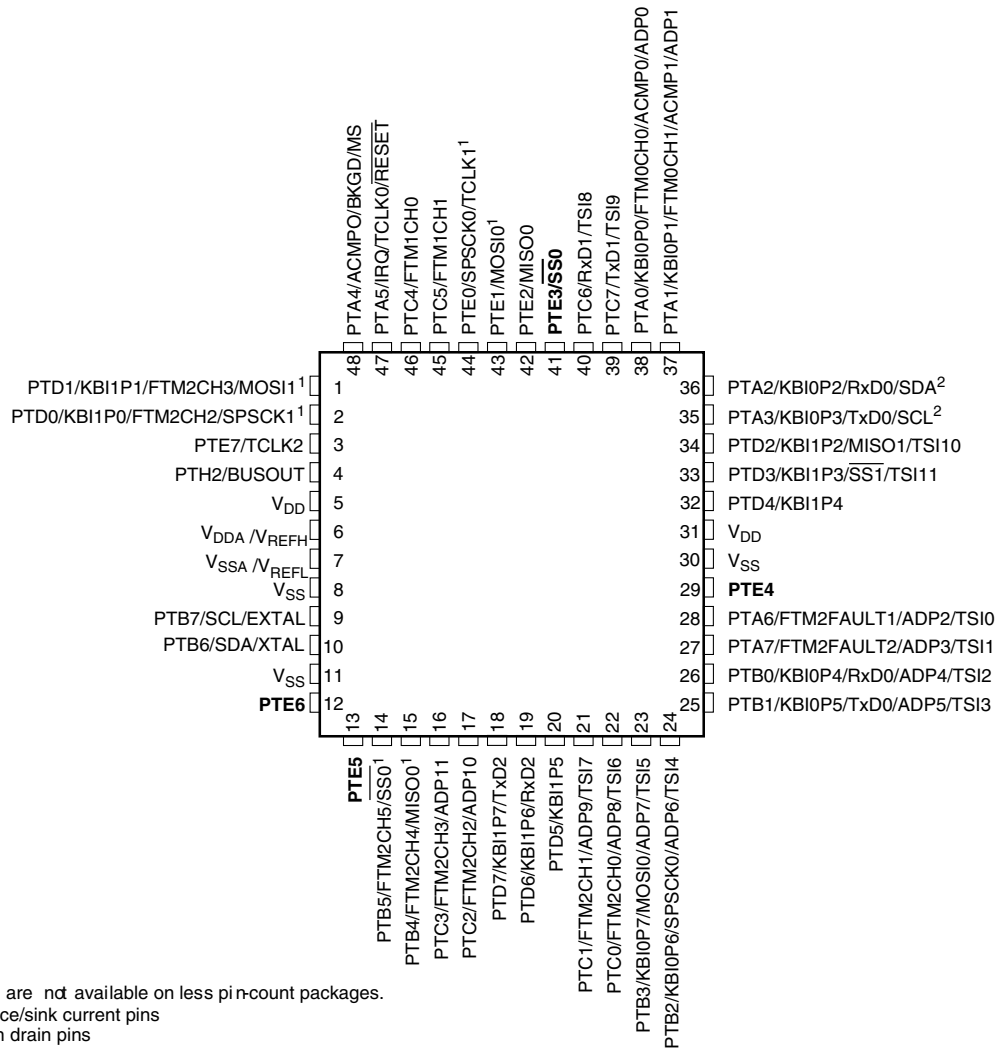

Pins in **bold** are not available on less pin-count packages.
 1. High source/sink current pins
 2. True open drain pins

Figure 18. MC9S08PT60 48-pin LQFP package

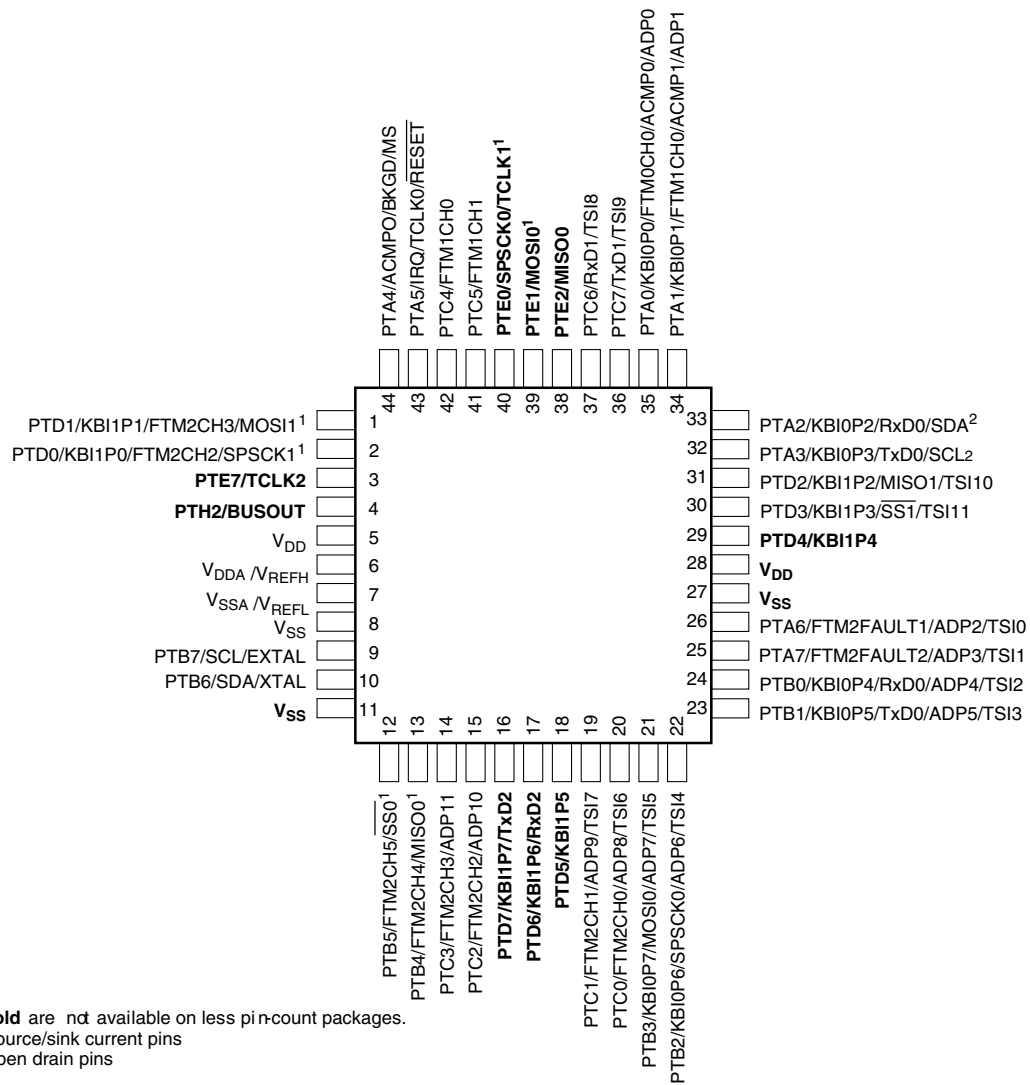
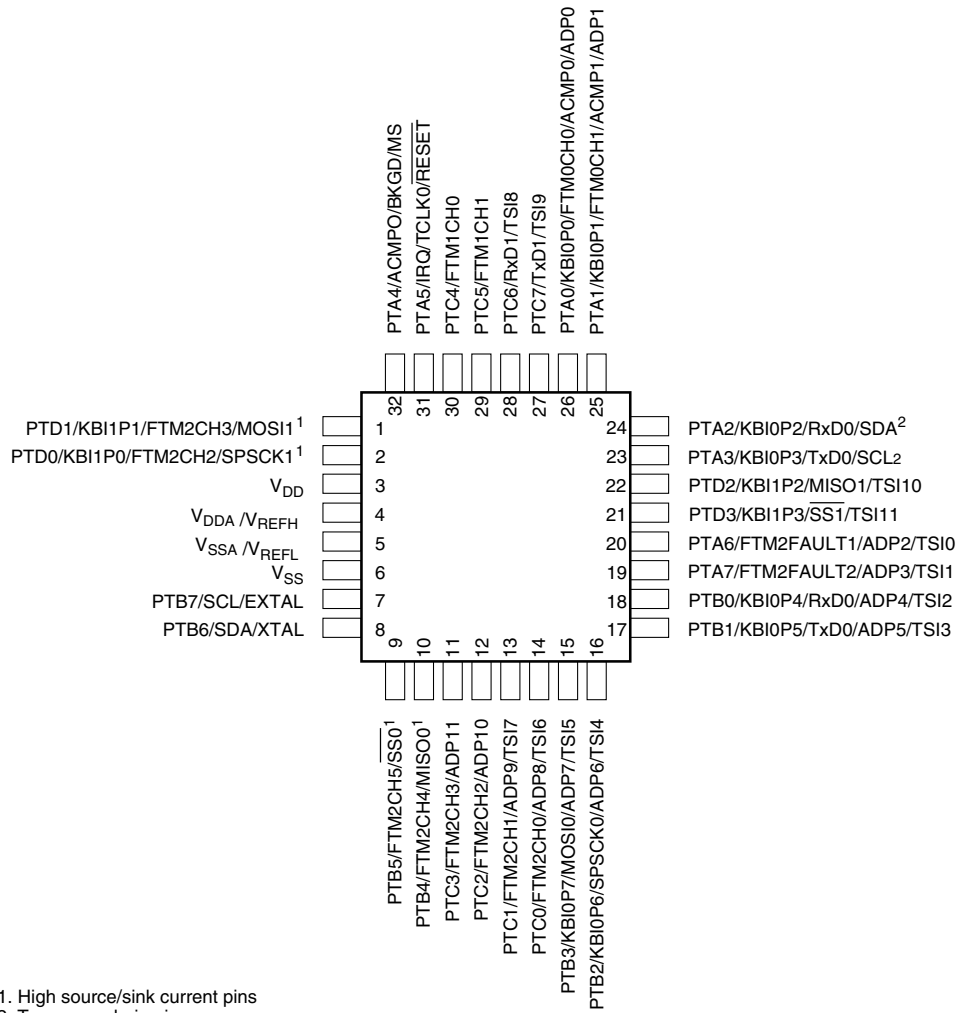

Figure 19. MC9S08PT60 44-pin LQFP package



- 1. High source/sink current pins
- 2. True open drain pins

Figure 20. MC9S08PT60 32-pin LQFP package

9 Revision history

The following table provides a revision history for this document.

Table 18. Revision history

Rev. No.	Date	Substantial Changes
1	10/2011	Initial public revision.
2	11/2011	<ul style="list-style-type: none"> • Updated some TBDs • Updated LVD and POR data • Updated ADC data • Updated SPI data • Updated TSI data.
3	4/2012	<ul style="list-style-type: none"> • Finished all the TBDs • Updated package information

How to Reach Us:

Home Page:

www.freescale.com

Web Support:

<http://www.freescale.com/support>

USA/Europe or Locations Not Listed:

Freescale Semiconductor
Technical Information Center, EL516
2100 East Elliot Road
Tempe, Arizona 85284
+1-800-521-6274 or +1-480-768-2130
www.freescale.com/support

Europe, Middle East, and Africa:

Freescale Halbleiter Deutschland GmbH
Technical Information Center
Schatzbogen 7
81829 Muenchen, Germany
+44 1296 380 456 (English)
+46 8 52200080 (English)
+49 89 92103 559 (German)
+33 1 69 35 48 48 (French)
www.freescale.com/support

Japan:

Freescale Semiconductor Japan Ltd.
Headquarters
ARCO Tower 15F
1-8-1, Shimo-Meguro, Meguro-ku,
Tokyo 153-0064
Japan
0120 191014 or +81 3 5437 9125
support.japan@freescale.com

Asia/Pacific:

Freescale Semiconductor China Ltd.
Exchange Building 23F
No. 118 Jianguo Road
Chaoyang District
Beijing 100022
China
+86 10 5879 8000
support.asia@freescale.com

Information in this document is provided solely to enable system and software implementers to use Freescale Semiconductors products. There are no express or implied copyright licenses granted hereunder to design or fabricate any integrated circuits or integrated circuits based on the information in this document.

Freescale Semiconductor reserves the right to make changes without further notice to any products herein. Freescale Semiconductor makes no warranty, representation, or guarantee regarding the suitability of its products for any particular purpose, nor does Freescale Semiconductor assume any liability arising out of the application or use of any product or circuit, and specifically disclaims any liability, including without limitation consequential or incidental damages. "Typical" parameters that may be provided in Freescale Semiconductor data sheets and/or specifications can and do vary in different applications and actual performance may vary over time. All operating parameters, including "Typicals", must be validated for each customer application by customer's technical experts. Freescale Semiconductor does not convey any license under its patent rights nor the rights of others. Freescale Semiconductor products are not designed, intended, or authorized for use as components in systems intended for surgical implant into the body, or other applications intended to support or sustain life, or for any other application in which failure of the Freescale Semiconductor product could create a situation where personal injury or death may occur. Should Buyer purchase or use Freescale Semiconductor products for any such unintended or unauthorized application, Buyer shall indemnify Freescale Semiconductor and its officers, employees, subsidiaries, affiliates, and distributors harmless against all claims, costs, damages, and expenses, and reasonable attorney fees arising out of, directly or indirectly, any claim of personal injury or death associated with such unintended or unauthorized use, even if such claims alleges that Freescale Semiconductor was negligent regarding the design or manufacture of the part.

RoHS-compliant and/or Pb-free versions of Freescale products have the functionality and electrical characteristics as their non-RoHS-complaint and/or non-Pb-free counterparts. For further information, see <http://www.freescale.com> or contact your Freescale sales representative.

For information on Freescale's Environmental Products program, go to <http://www.freescale.com/epp>.

Freescale™ and the Freescale logo are trademarks of Freescale Semiconductor, Inc. All other product or service names are the property of their respective owners.

© 2011–2012 Freescale Semiconductor, Inc.