VFM STEP-UP DC/DC CONVERTER

RH5RI××1B/××2B/××3B SERIES

APPLICATION MANUAL

NO.EA-025-0006

RH5RI××1B/××2B/××3B SERIES

OUTLINE

The RH5RI××1B/××2B/××3B Series are VFM (Chopper) Step-up DC/DC converter ICs with ultra low supply current by CMOS process.

The RH5RI××1B IC consists of an oscillator, a VFM control circuit, a driver transistor (Lx switch), a reference voltage unit, an error amplifier, resistors for voltage detection, and an Lx switch protection circuit. A low ripple, high efficiency step-up DC/DC converter can be constructed of this RH5RI××1B IC with only three external components, that is, an inductor, a diode and a capacitor.

The RH5RI××2B IC uses the same chip as that employed in the RH5RI××1B IC and is provided with a drive pin (EXT) for an external transistor instead of an Lx pin, so that a power transistor with a low saturation voltage can be externally provided, whereby a large current can be caused to flow through the inductor and accordingly a large current can be obtained. Therefore, the RH5RI××2B IC is recommendable to the user who need a current as large as several tens mA to several hundreds mA.

The RH5RI××3B IC also includes an internal chip enable circuit so that it is possible to set the standby supply current at MAX. 0.5µA.

These RH5RI××1B/××2B/××3B ICs are suitable for use with battery-powered instruments with low noise and ultra low supply current.

FEATURES

- Small Number of External ComponentsOnly an inductor, a diode and a capacitor (RH5RI××1B)
- Ultra Low Input CurrentTYP. 4µA (RH5RI301B/303B at no load,with 1.5V input)
- High Output Voltage Accuracy±2.5%
- Low Ripple and Low Noise
- Low Start-up Voltage (When the output current is 1mA).....MAX. 0.9V
- High EfficiencyTYP.80%
- Low Temperature-Drift Coefficient of Output VoltageTYP. ±50 ppm/°C
- Small Packages.....SOT-89 (RH5RI××1B, RH5RI××2B)
SOT-89-5 (RH5RI××3B)

APPLICATIONS

- Power source for battery-powered equipment.
- Power source for cameras, camcorders, VCRs, PDAs, electronic data banks, and hand-held communication equipment.
- Power source for appliances which require higher cell voltage than that of batteries used in the appliances.

BLOCK DIAGRAM

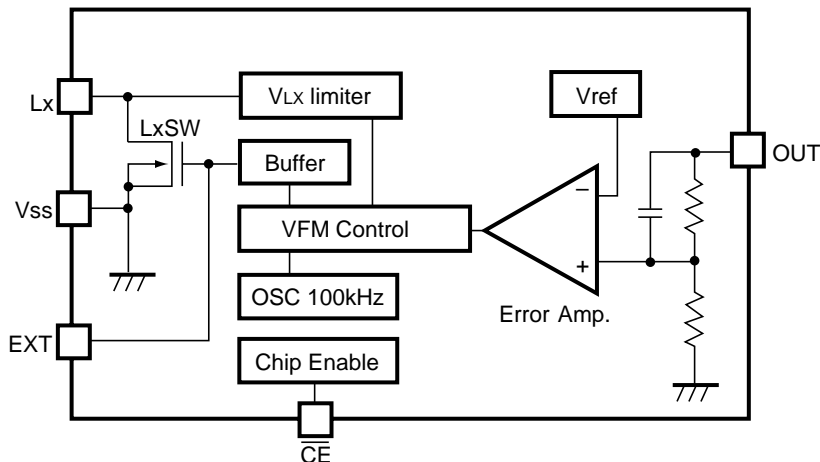

(Note) Lx Pin.....only for RH5RI××1B and RH5RI××3B
 EXT Pin.....only for RH5RI××2B and RH5RI××3B
 $\overline{\text{CE}}$ Pin.....only for RH5RI××3B

SELECTION GUIDE

In RH5RI Series, the output voltage, the driver, and the taping type for the ICs can be selected at the user's request. The selection can be made by designating the part number as shown below :

RH5RI×××× - ×× ← Part Number
 ↑ ↑ ↑
 a b c

Code	Contents
a	Setting Output Voltage (V _{OUT}): Stepwise setting with a step of 0.1V in the range of 2.5V to 7.5V is possible.
b	Designation of Driver: 1B: Internal Lx Tr. Driver (Oscillator Frequency 100kHz) 2B: External Tr. Driver (Oscillator Frequency 100kHz) 3B: Internal Tr./External Tr. (selectively available) (Oscillator Frequency 100kHz, with chip enable function)
c	Designation of Taping type : Ex. SOT-89 : T1, T2 SOT-89-5 : T1, T2 (refer to Taping Specification) "T1" is prescribed as a standard.

For example, the product with Output Voltage 5.0V, the External Driver (the Oscillator Frequency 100kHz) and Taping Type T1, is designated by Part Number RH5RI502B-T1.

PIN CONFIGURATION

• SOT-89

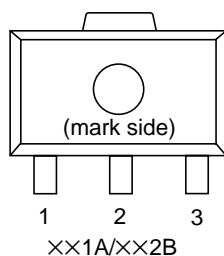

• SOT-89-5

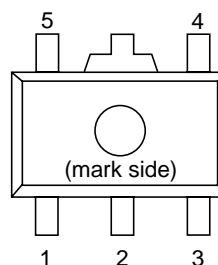

PIN DESCRIPTION

Pin No.			Symbol	Description
××1B	××2B	××3B		
1	1	5	Vss	Ground Pin
2	2	2	OUT	Step-up Output Pin, Power Supply (for device itself)
3	—	4	Lx	Switching Pin (Nch Open Drain)
—	3	3	EXT	External Tr. Drive Pin (CMOS Output)
—	—	1	$\overline{\text{CE}}$	Chip Enable Pin (Active Low)

ABSOLUTE MAXIMUM RATINGS

V_{SS}=0V

Symbol	Item	Rating	Unit	Note
V _{OUT}	Output Pin Voltage	+12	V	
V _{LX}	L _x Pin Voltage	+12	V	Note1
V _{EXT}	EXT Pin Voltage	-0.3 to V _{OUT} +0.3	V	Note2
V _{CE}	$\overline{\text{CE}}$ Pin Voltage	-0.3 to V _{OUT} +0.3	V	Note3
I _{LX}	L _x Pin Output Current	250	mA	Note1
I _{EXT}	EXT Pin Current	±50	mA	Note2
P _D	Power Dissipation	500	mW	
T _{opt}	Operating Temperature Range	-30 to +80	°C	
T _{stg}	Storage Temperature Range	-55 to +125	°C	
T _{solder}	Lead Temperature (Soldering)	260°C, 10s		

(Note 1) Applicable to RH5RI××1A and RH5RI××3B.

(Note 2) Applicable to RH5RI××2B and RH5RI××3B.

(Note 3) Applicable to RH5RI××3B.

ABSOLUTE MAXIMUM RATINGS

Absolute Maximum ratings are threshold limit values that must not be exceeded even for an instant under any conditions. Moreover, such values for any two items must not be reached simultaneously. Operation above these absolute maximum ratings may cause degradation or permanent damage to the device. These are stress ratings only and do not necessarily imply functional operation below these limits.

ELECTRICAL CHARACTERISTICS

• RH5RI301B

 $V_{OUT}=3.0V$

Symbol	Item	Conditions	MIN.	TYP.	MAX.	Unit	Note
V_{OUT}	Output Voltage		2.925	3.000	3.075	V	
V_{IN}	Input Voltage				8	V	
V_{start}	Start-up Voltage	$I_{OUT}=1mA, V_{IN}:0 \rightarrow 2V$		0.8	0.9	V	
V_{hold}	Hold-on Voltage	$I_{OUT}=1mA, V_{IN}:2 \rightarrow 0V$	0.7			V	
I_{IN1}	Input Current 1	To be measured at V_{IN} at no load		4	8	μA	
I_{IN2}	Input Current 2	To be measured at V_{IN} $V_{IN}=3.5V$		2	5	μA	
I_{LX}	Lx Switching Current	$V_{LX}=0.4V$	60			mA	
I_{LXleak}	Lx Leakage Current	$V_{LX}=6V, V_{IN}=3.5V$			0.5	μA	
f_{osc}	Maximum Oscillator Frequency		80	100	120	kHz	
Maxdty	Oscillator Duty Cycle	on (V_{LX} "L") side	65	75	85	%	
η	Efficiency		70	80		%	
V_{LXlim}	V_{LX} Voltage Limit	Lx Switch On	0.65	0.8	1.0	V	Note

Unless otherwise provided, $V_{IN}=1.8V$, $V_{SS}=0V$, $I_{OUT}=10mA$, $T_{opt}=25^{\circ}C$, and use External Circuit of Typical Application (FIG. 1).

(Note) I_{LX} is gradually increased by the external inductor after Lx Switch is turned ON. In accordance with the increase of I_{LX} , V_{LX} is also increased. When V_{LX} reaches V_{LXlim} , Lx Switch is turned OFF by Lx Switch Protection Circuit. The time period from the time at which V_{LX} reaches V_{LXlim} to the time at which Lx Switch is turned OFF is about $3\mu s$.

• RH5RI501B

V_{OUT}=5.0V

Symbol	Item	Conditions	MIN.	TYP.	MAX.	Unit	Note
V _{OUT}	Output Voltage		4.875	5.000	5.125	V	
V _{IN}	Input Voltage				8	V	
V _{start}	Start-up Voltage	I _{OUT} =1mA, V _{IN} :0→2V		0.8	0.9	V	
V _{hold}	Hold-on Voltage	I _{OUT} =1mA, V _{IN} :2→0V	0.7			V	
I _{IN1}	Input Current 1	To be measured at V _{IN} at no load		6	12	μA	
I _{IN2}	Input Current 2	To be measured at V _{IN} V _{IN} =5.5V		2	5	μA	
I _{LX}	L _x Switching Current	V _{LX} =0.4V	80			mA	
I _{LXleak}	L _x Leakage Current	V _{LX} =6V, V _{IN} =5.5V			0.5	μA	
f _{osc}	Maximum Oscillator Frequency		80	100	120	kHz	
Maxdty	Oscillator Duty Cycle	on (V _{LX} "L") side	65	75	85	%	
η	Efficiency		70	80		%	
V _{LXlim}	V _{LX} Voltage Limit	L _x Switch On	0.65	0.8	1.0	V	Note2

Unless otherwise provided, V_{IN}=3V, V_{SS}=0V, I_{OUT}=10mA, T_{opt}=25°C, and use External Circuit of Typical Application (FIG. 1).

(Note) I_{LX} is gradually increased by the external inductor after L_x Switch is turned ON. In accordance with the increase of I_{LX}, V_{LX} is also increased. When V_{LX} reaches V_{LXlim}, L_x Switch is turned OFF by L_x Switch Protection Circuit. The time period from the time at which V_{LX} reaches V_{LXlim} to the time at which L_x Switch is turned OFF is about 3μs.

• RH5RI302B

V_{OUT}=3.0V

Symbol	Item	Conditions	MIN.	TYP.	MAX.	Unit	Note
V _{OUT}	Output Voltage		2.925	3.000	3.075	V	
V _{IN}	Input Voltage				8	V	
V _{start}	Oscillator Start-up Voltage	EXT at no load, V _{OUT} :0→2V		0.7	0.8	V	
I _{DD1}	Supply Current 1	EXT at no load, V _{OUT} =2.88V		30	50	μA	
I _{DD2}	Supply Current 2	EXT at no load, V _{OUT} =3.5V		2	5	μA	
I _{EXTH}	EXT “H” Output Current	V _{EXT} =V _{OUT} -0.4V			-1.5	mA	
I _{EXTL}	EXT “L” Output Current	V _{EXT} =0.4V	1.5			mA	
f _{osc}	Maximum Oscillator Frequency		80	100	120	kHz	
Maxdty	Oscillator Duty Cycle	V _{EXT} “H” side	65	75	85	%	

Unless otherwise provided, V_{IN}=1.8V, V_{SS}=0V, I_{OUT}=10mA, T_{opt}=25°C, and use External Circuit of Typical Application (FIG. 2).

• RH5RI502B

V_{OUT}=5.0V

Symbol	Item	Conditions	MIN.	TYP.	MAX.	Unit	Note
V _{OUT}	Output Voltage		4.875	5.000	5.125	V	
V _{IN}	Input Voltage				8	V	
V _{start}	Oscillator Start-up Voltage	EXT at no load, V _{OUT} :0→2V		0.7	0.8	V	
I _{DD1}	Supply Current 1	EXT at no load, V _{OUT} =4.8V		60	90	μA	
I _{DD2}	Supply Current 2	EXT at no load, V _{OUT} =5.5V		2	5	μA	
I _{EXTH}	EXT “H” Output Current	V _{EXT} =V _{OUT} -0.4V			-2	mA	
I _{EXTL}	EXT “L” Output Current	V _{EXT} =0.4V	2			mA	
f _{osc}	Maximum Oscillator Frequency		80	100	120	kHz	
Maxdty	Oscillator Duty Cycle	V _{EXT} “H” side	65	75	85	%	

Unless otherwise provided, V_{IN}=3V, V_{SS}=0V, I_{OUT}=10mA, T_{opt}=25°C, and use External Circuit of Typical Application (FIG. 2).

• RH5RI303B

V_{OUT}=3.0V

Symbol	Item	Conditions	MIN.	TYP.	MAX.	Unit	Note
V _{OUT}	Output Voltage		2.925	3.000	3.075	V	
V _{IN}	Input Voltage				8	V	
V _{start}	Start-up Voltage	I _{OUT} =1mA, V _{IN} :0→2V		0.8	0.9	V	
V _{hold}	Hold-on Voltage	I _{OUT} =1mA, V _{IN} :2→0V	0.7			V	
η	Efficiency		70	80		%	
I _{IN1}	Input Current 1	To be measured at V _{IN} at no load		4	8	μA	
I _{IN2}	Input Current 2	To be measured at V _{IN} V _{IN} =3.5V		2	5	μA	
I _{LX}	Lx Switching Current	V _{LX} =0.4V	60			mA	
I _{LXleak}	Lx Leakage Current	V _{LX} =6V, V _{IN} =3.5V			0.5	μA	
I _{EXTH}	EXT “H” Output Current	V _{EXT} =V _{OUT} -0.4V			-1.5	mA	
I _{EXTL}	EXT “L” Output Current	V _{EXT} =0.4V	1.5			mA	
V _{CEH1}	\overline{CE} “H” Level 1	V _{OUT} ≥1.5V	V _{OUT} -0.4			V	
V _{CEL1}	\overline{CE} “L” Level 1	V _{OUT} ≥1.5V			0.4	V	
V _{CEH2}	\overline{CE} “H” Level 2	0.8V≤V _{OUT} <1.5V	V _{OUT} -0.1			V	
V _{CEL2}	\overline{CE} “L” Level 2	0.8V≤V _{OUT} <1.5V			0.1	V	
I _{CEH}	\overline{CE} “H” Input Current	\overline{CE} =3V			0.5	μA	
I _{CEL}	\overline{CE} “L” Input Current	\overline{CE} =0V	-0.5			μA	
f _{osc}	Maximum Oscillator Frequency		80	100	120	kHz	
Maxdty	Oscillator Duty Cycle	on (V _{LX} “L”)side	65	75	85	%	
V _{LXlim}	V _{LX} Voltage Limit	Lx Switch on	0.65	0.8	1.0	V	Note

Unless otherwise provided, V_{IN}=1.8V, V_{SS}=0V, I_{OUT}=10mA, T_{opt}=25°C, and use External Circuit of Typical Application (FIG. 3).

(Note) I_{LX} is gradually increased by the external inductor after Lx Switch is turned ON. In accordance with the increase of I_{LX}, V_{LX} is also increased. When V_{LX} reaches V_{LXlim}, Lx Switch is turned OFF by Lx Switch Protection Circuit. The time period from the time at which V_{LX} reaches V_{LXlim} to the time at which Lx Switch is turned OFF is about 3μs.

• RH5RI503B

V_{OUT}=5.0V

Symbol	Item	Conditions	MIN.	TYP.	MAX.	Unit	Note
V _{OUT}	Output Voltage		4.875	5.000	5.125	V	
V _{IN}	Input Voltage				8	V	
V _{start}	Start-up Voltage	I _{OUT} =1mA, V _{IN} :0→2V		0.8	0.9	V	
V _{hold}	Hold-on Voltage	I _{OUT} =1mA, V _{IN} :2→0V	0.7			V	
η	Efficiency		70	85		%	
I _{IN1}	Input Current 1	To be measured at V _{IN} at no load		6	12	μA	
I _{IN2}	Input Current 2	To be measured at V _{IN} V _{IN} =5.5V		2	5	μA	
I _{LX}	L _x Switching Current	V _{LX} =0.4V	80			mA	
I _{LXleak}	L _x Leakage Current	V _{LX} =6V, V _{IN} =5.5V			0.5	μA	
I _{EXTH}	EXT “H” Output Current	V _{EXT} =V _{OUT} -0.4V			-2.0	mA	
I _{EXTL}	EXT “L” Output Current	V _{EXT} =0.4V	2.0			mA	
V _{CEH1}	$\overline{\text{CE}}$ “H” Level 1	V _{OUT} ≥1.5V	V _{OUT} -0.4			V	
V _{CEL1}	$\overline{\text{CE}}$ “L” Level 1	V _{OUT} ≥1.5V			0.4	V	
V _{CEH2}	$\overline{\text{CE}}$ “H” Level 2	0.8V≤V _{OUT} <1.5V	V _{OUT} -0.1			V	
V _{CEL2}	$\overline{\text{CE}}$ “L” Level 2	0.8V≤V _{OUT} <1.5V			0.1	V	
I _{CEH}	$\overline{\text{CE}}$ “H” Input Current	$\overline{\text{CE}}$ =5V			0.5	μA	
I _{CEL}	$\overline{\text{CE}}$ “L” Input Current	$\overline{\text{CE}}$ =0V	-0.5			μA	
f _{osc}	Maximum Oscillator Frequency		80	100	120	kHz	
Maxdty	Oscillator Duty Cycle	on (V _{LX} “L”)side	65	75	85	%	
V _{LXlim}	V _{LX} Voltage Limit	L _x Switch on	0.65	0.8	1.0	V	Note

Unless otherwise provided, V_{IN}=3V, V_{SS}=0V, I_{OUT}=10mA, T_{opt}=25°C and use External Circuit of Typical Application (FIG. 3).

(Note) I_{LX} is gradually increased by the external inductor after L_x Switch is turned ON. In accordance with the increase of I_{LX}, V_{LX} is also increased. When V_{LX} reaches V_{LXlim}, L_x Switch is turned OFF by L_x Switch Protection Circuit. The time period from the time at which V_{LX} reaches V_{LXlim} to the time at which L_x Switch is turned OFF is about 3μs.

OPERATION OF STEP-UP DC/DC CONVERTER

Step-up DC/DC Converter charges energy in the inductor when Lx Transistor (LxTr) is on, and discharges the energy with the addition of the energy from Input Power Source thereto, so that a higher output voltage than the input voltage is obtained.

The operation will be explained with reference to the following diagrams :

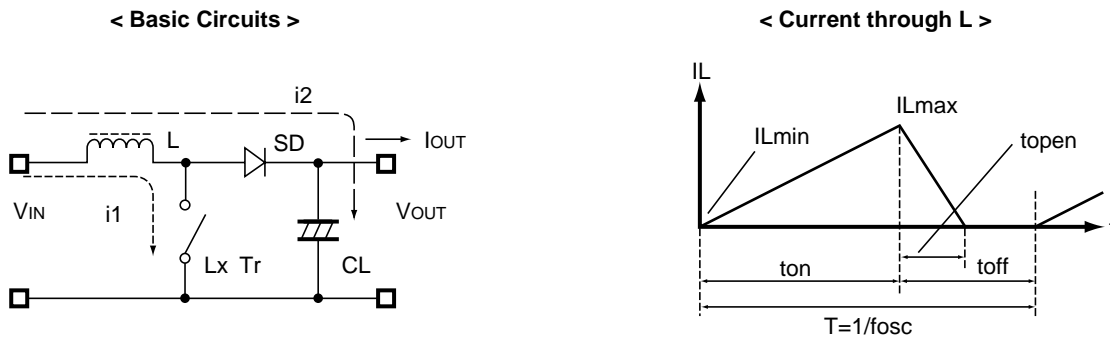

Step 1 : LxTr is turned ON and current $I_L (=i_1)$ flows, so that energy is charged in L. At this moment, $I_L(=i_1)$ is increased from $I_{Lmin} (=0)$ to reach I_{Lmax} in proportion to the on-time period (ton) of LxTr.

Step 2 : When LxTr is turned OFF, Schottky diode (SD) is turned on in order that L maintains I_L at I_{Lmax} , so that current $I_L (=i_2)$ is released.

Step 3 : $I_L (=i_2)$ is gradually decreased, and I_L reaches $I_{Lmin} (=0)$ after a time period of $topen$, so that SD is turned OFF.

In the case of VFM control system, the output voltage is maintained constant by controlling the oscillator frequency ($fosc$) with the on-time period (ton) being maintained constant.

In the above two diagrams, the maximum value (I_{Lmax}) and the minimum value (I_{Lmin}) of the current which flows through the inductor are the same as those when LxTr is ON and also when LxTr is OFF.

The difference between I_{Lmax} and I_{Lmin} , which is represented by ΔI , is:

$$\Delta I = I_{Lmax} - I_{Lmin} = V_{IN} \cdot ton / L = (V_{OUT} - V_{IN}) \cdot topen / L \dots \dots \dots \text{Equation 1}$$

wherein $T = 1/fosc = ton + toff$

$$\text{duty (\%)} = ton / T \cdot 100 = ton \cdot fosc \cdot 100$$

$$topen \leq toff$$

In Equation 1, $V_{IN} \cdot ton / L$ and $(V_{OUT} - V_{IN}) \cdot topen / L$ are respectively the change in the current at ON, and the change in the current at OFF.

In the VFM system, $topen < toff$ as illustrated in the above diagram. In this case, the energy charged in the inductor during the time period of ton is discharged in its entirety during the time period of $toff$, so that I_{Lmin} becomes zero ($I_{Lmin} = 0$).

SELECTION OF PERIPHERAL COMPONENTS

When LxTr is on, the energy PON charged in the inductor is provided by Equation 2 as follows :

$$\begin{aligned} \text{PON} &= \int_0^{\text{ton}} (\text{VIN} \cdot \text{IL} (t)) dt = \int_0^{\text{ton}} (\text{VIN}^2 \cdot t/L) dt \\ &= \text{VIN}^2 \cdot \text{ton}^2 / (2 \cdot L) \dots \dots \dots \text{Equation 2} \end{aligned}$$

In the case of the step-up DC/DC converter, the energy is also supplied from the input power source at the time of OFF.

$$\begin{aligned} \text{Thus, POFF} &= \int_0^{\text{topen}} (\text{VIN} \cdot \text{IL} (t)) dt = \int_0^{\text{topen}} (\text{VIN} \cdot (\text{VOUT} - \text{VIN}) \cdot t/L) dt \\ &= \text{VIN} \cdot (\text{VOUT} - \text{VIN}) \cdot \text{topen}^2 / (2 \cdot L) \end{aligned}$$

Here, topen = VIN · ton / (VOUT - VIN) from Equation 1, and when this is substituted into the above equation.

$$= \text{VIN}^3 \cdot \text{ton}^2 / (2 \cdot L \cdot (\text{VOUT} - \text{VIN})) \dots \dots \dots \text{Equation 3}$$

Input power PIN is (PON+POFF)/T. When this is converted in its entirety to the output.

$$\text{PIN} = (\text{PON} + \text{POFF}) / T = \text{VOUT} \cdot \text{IOUT} = \text{POUT} \dots \dots \dots \text{Equation 4}$$

Equation 5 can be obtained as follows by solving Equation 4 for IOUT by substituting Equation 2 and 3 into Equation 4 :

$$\begin{aligned} \text{IOUT} &= \text{VIN}^2 \cdot \text{ton}^2 / (2 \cdot L \cdot T \cdot (\text{VOUT} - \text{VIN})) \\ &= \text{VIN}^2 \cdot \text{maxdty}^2 / (20000 \cdot \text{fosc} \cdot L \cdot (\text{VOUT} - \text{VIN})) \dots \dots \dots \text{Equation 5} \end{aligned}$$

The peak current which flows through L · LxTr · SD is

$$\text{ILmax} = \text{VIN} \cdot \text{ton} / L \dots \dots \dots \text{Equation 6}$$

Therefore, it is necessary that the setting of the input/output conditions and the selection of peripheral components be made with ILmax taken into consideration.

HINTS

The above explanation is directed to the calculation in an ideal case where it is supposed that there is no energy loss in the external components and LxSW. In an actual case, the maximum output current will be 50 to 80% of the above calculated maximum output current. In particular, care must be taken because VIN is decreased in an amount corresponding to the voltage reduction caused by LxSW when IL is large or VIN is small. Furthermore, It is required that with respect to VOUT, Vf of the diode (about 0.3V in the case of a Schottky type diode) be taken into consideration.

When ILX and VLX exceed their respective ratings, use RH5RI××2B and RH5RI××3B ICs with the attachment of an external transistor with a low saturation voltage thereto.

TYPICAL CHARACTERISTICS

1) Output Voltage vs. Output Current

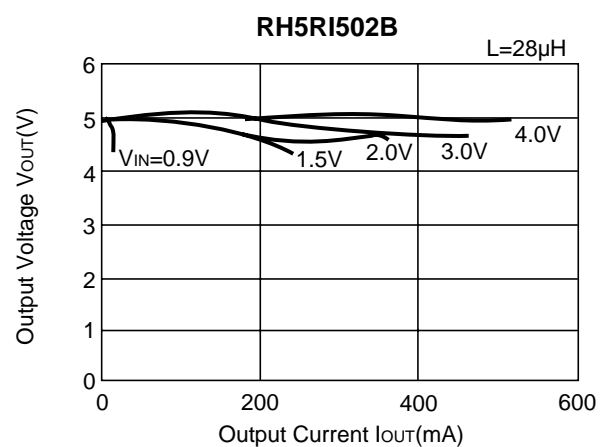
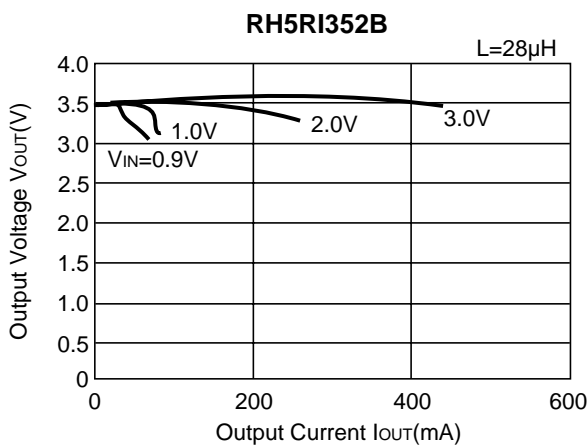
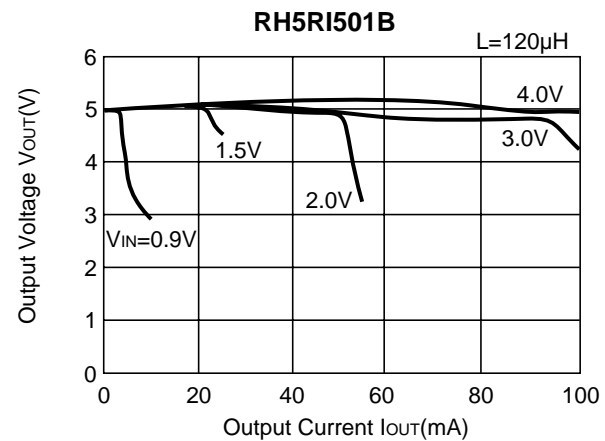
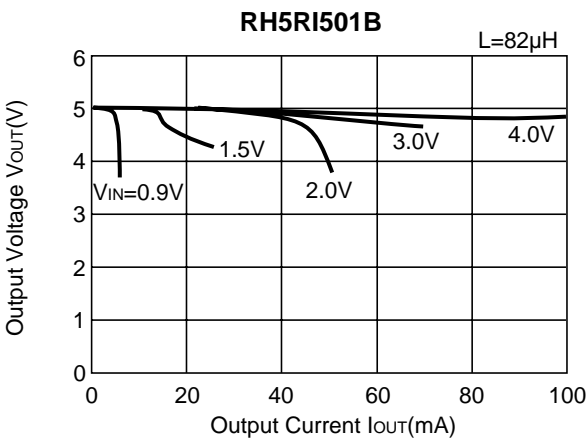
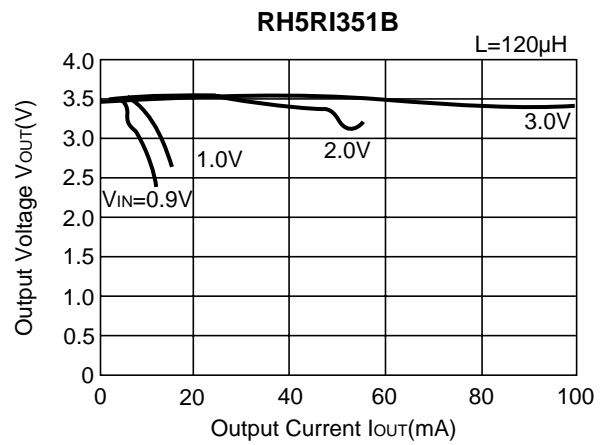
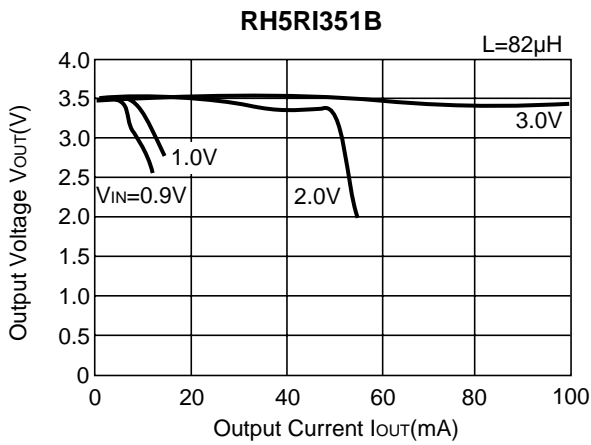

2) Efficiency vs. Output Current

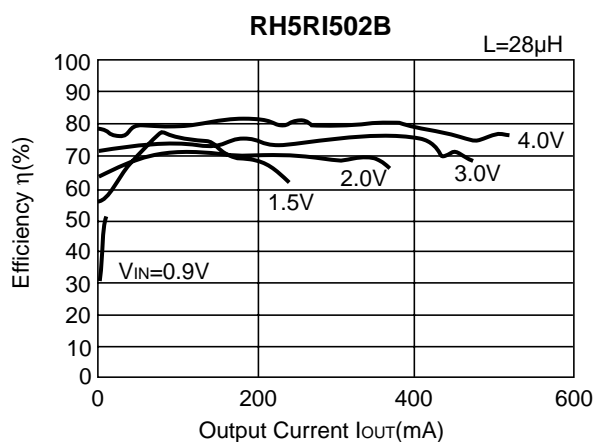
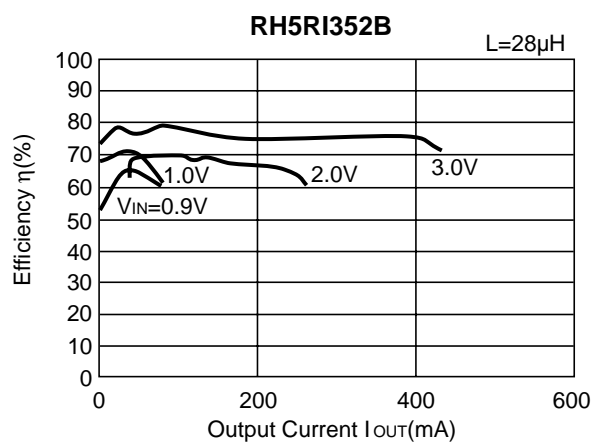
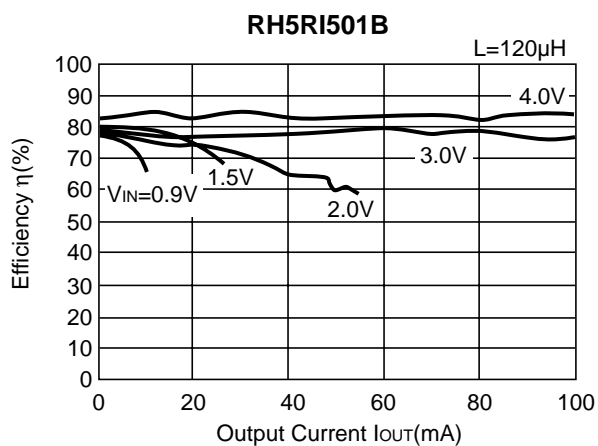
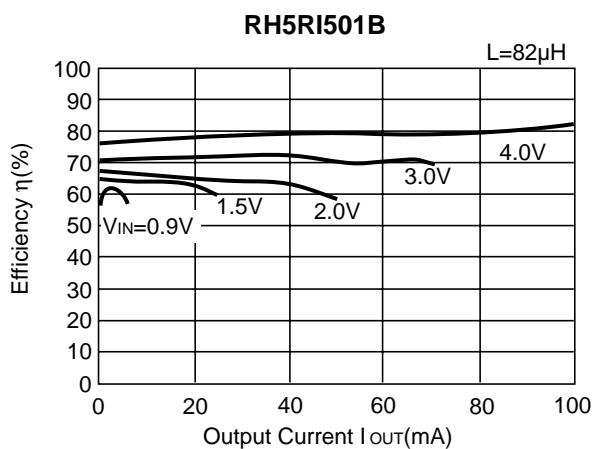
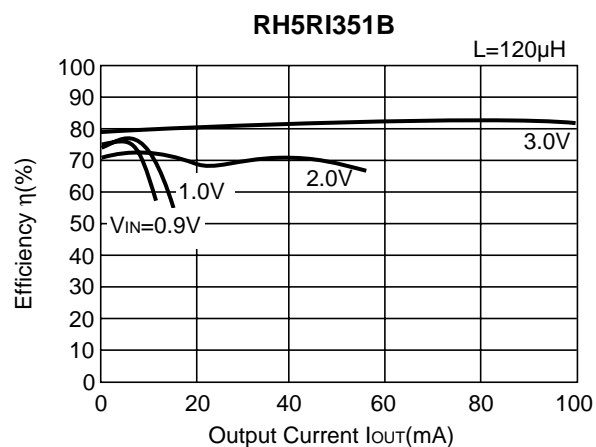
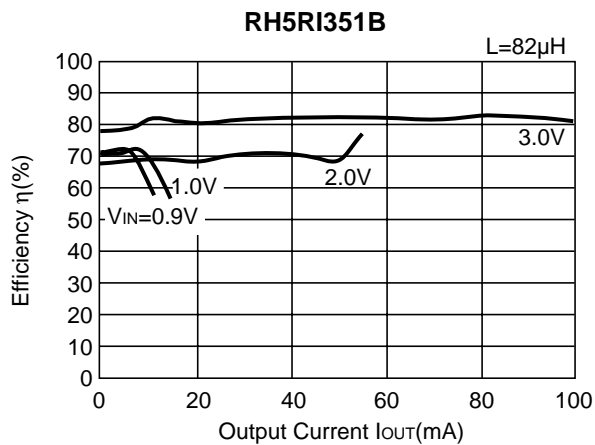

3) Output Current vs. Ripple Voltage

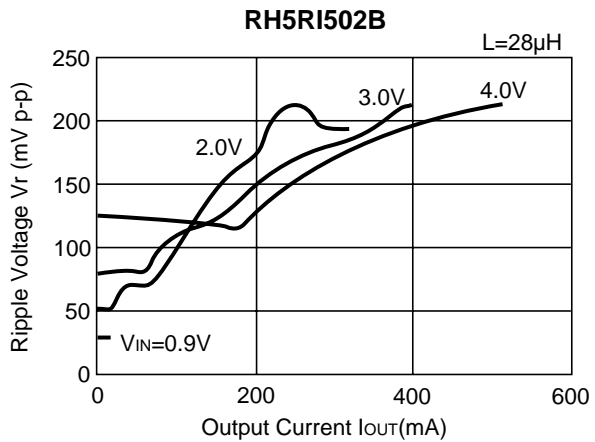
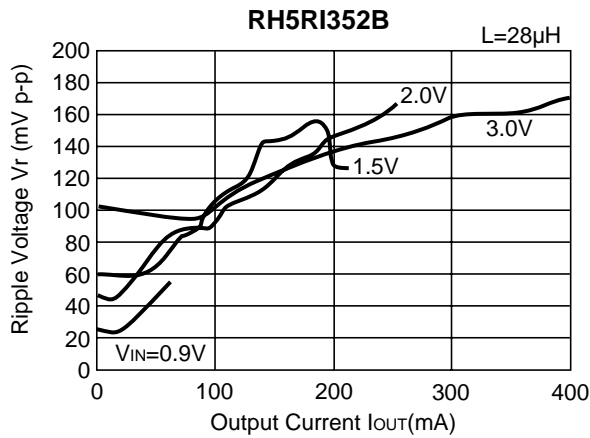
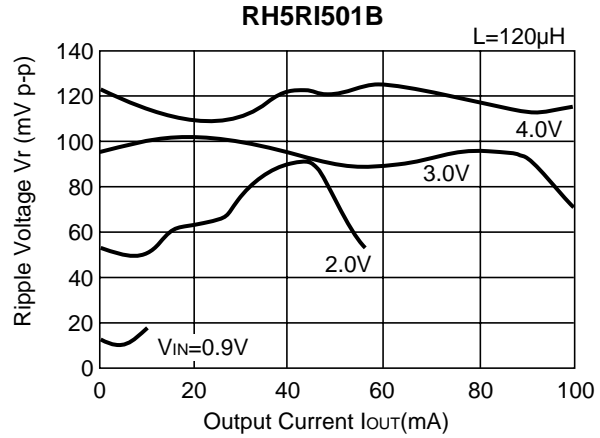
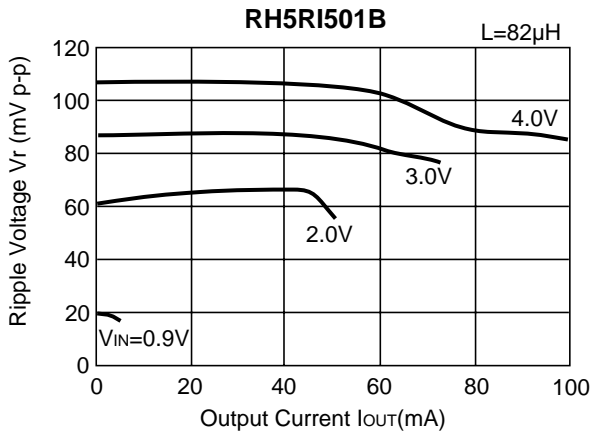
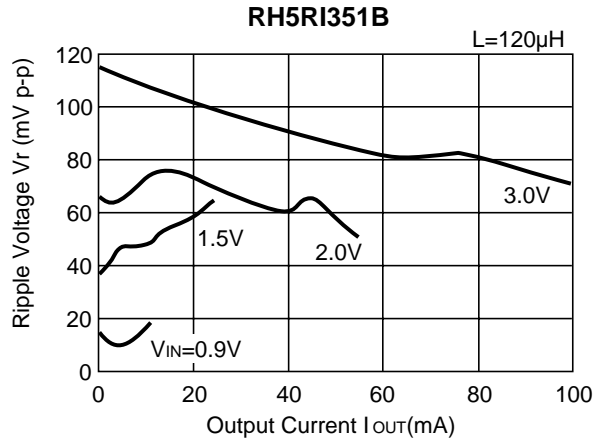
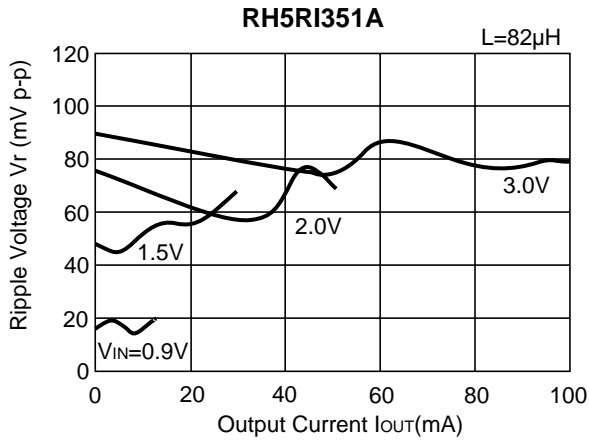

4) Start-up/Hold-on Voltage vs. Output Current

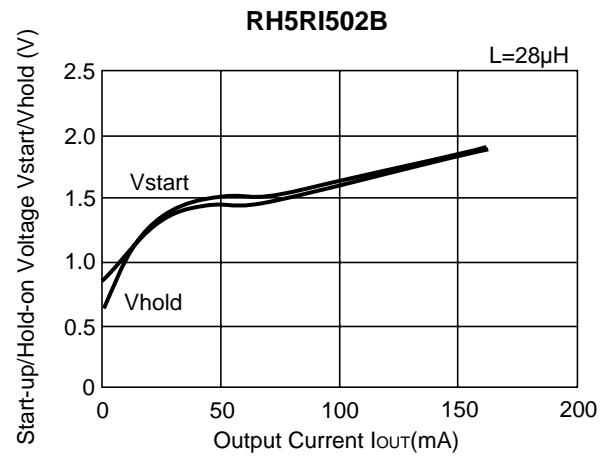
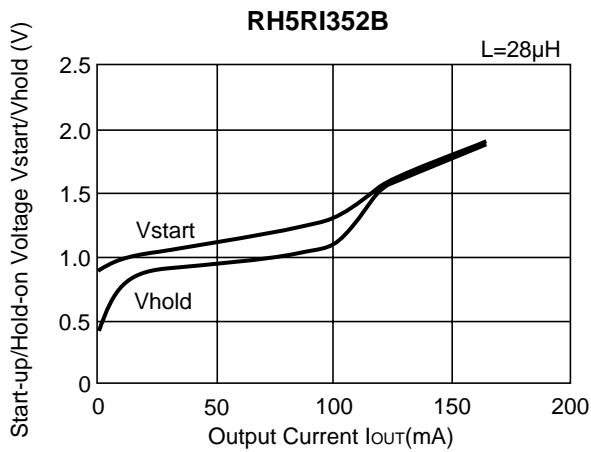
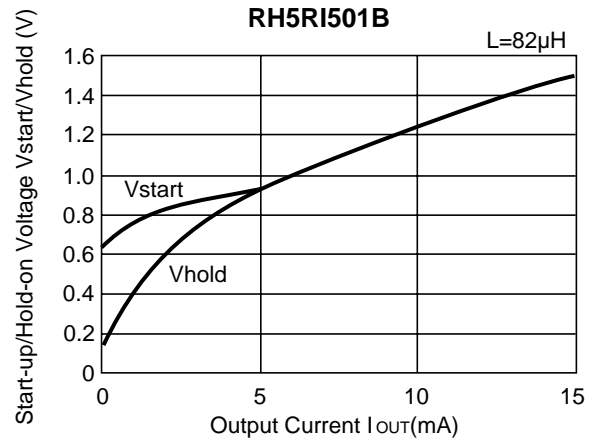
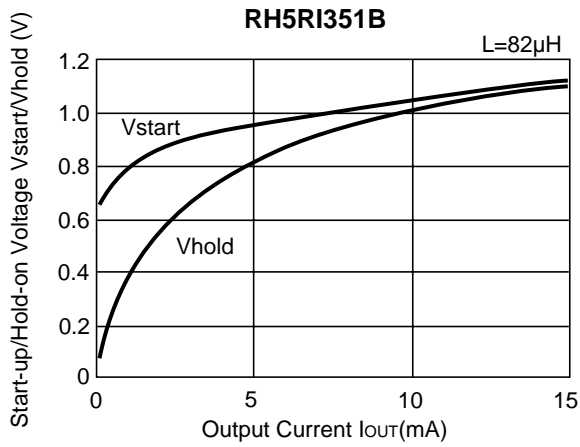

5) Output Voltage vs. Temperature

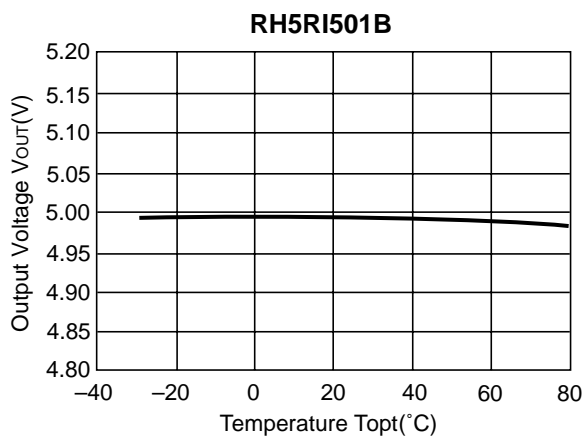

6) Start-up Voltage vs. Temperature

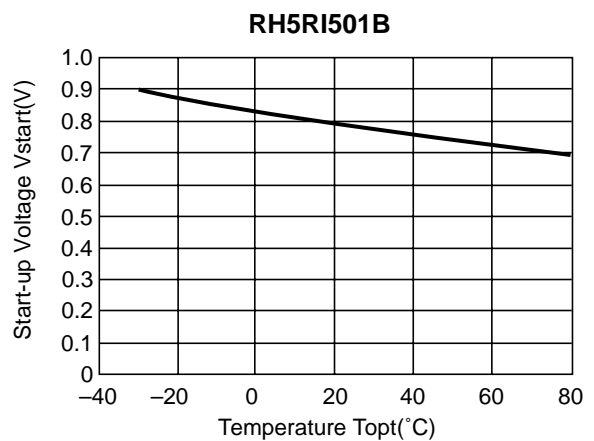

7) Hold-on Voltage vs. Temperature

RH5RI501B

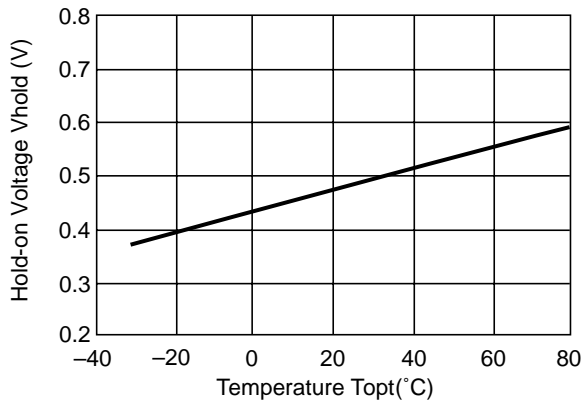

8) Supply Current 1 vs. Temperature

RH5RI502B

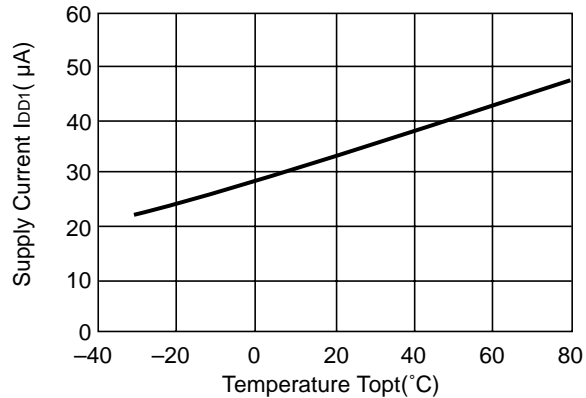

9) Input Current 2 vs. Temperature

RH5RI501B

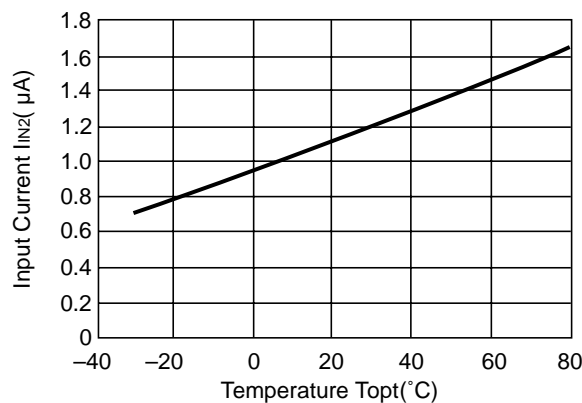

10) Lx Switching Current vs. Temperature

RH5RI501B

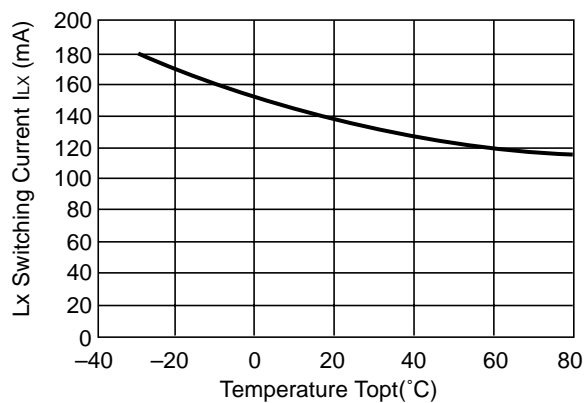

11) Lx Leakage Current vs. Temperature

RH5RI501B

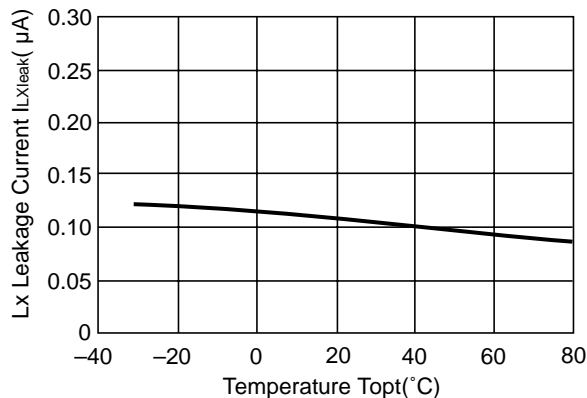

12) Maximum Oscillator Frequency vs. Temperature

RH5RI501B

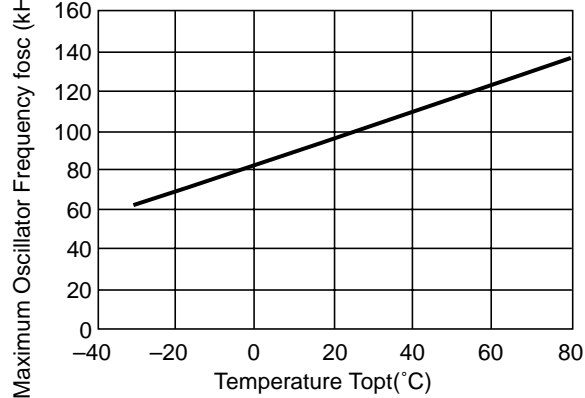

13) Oscillatar Duty Cycle vs. Temperature

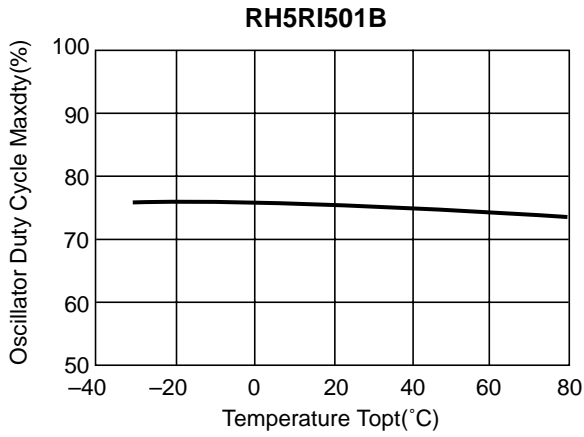

14) Vlx Voltage Limit vs. Temperature

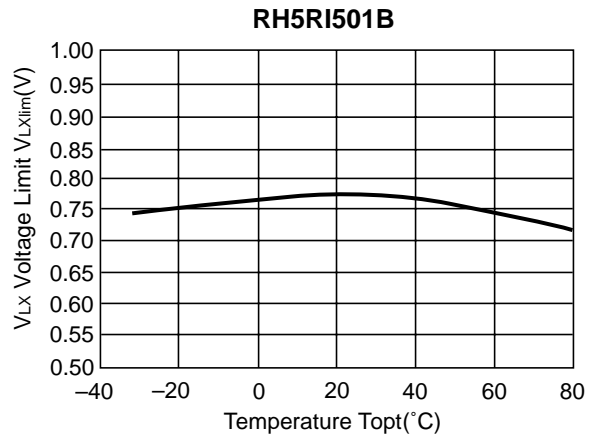

15) Output Current vs. Temperature

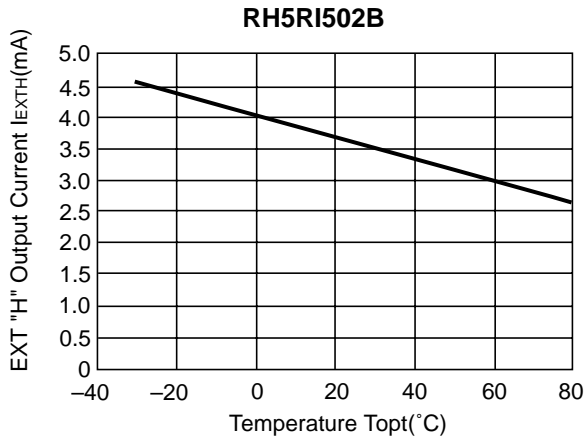

16) Output Current vs. Temperature

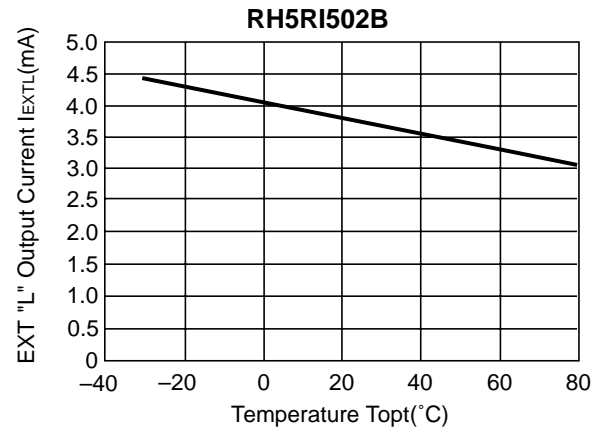

TYPICAL APPLICATIONS

• RH5RI××1B

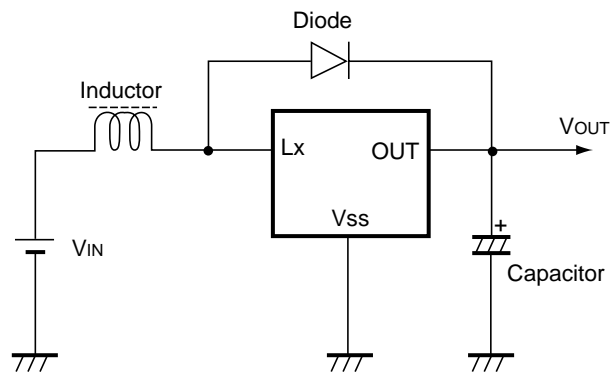

- Components Inductor (L) : 82 μ H (Sumida Electric Co., Ltd.)
- Diode (D) : MA721 (Matsushita Electronics Corporation, Schottky Type)
- Capacitor (CL) : 22 μ F (Tantalum Type)

FIG. 1

• RH5RI××2B

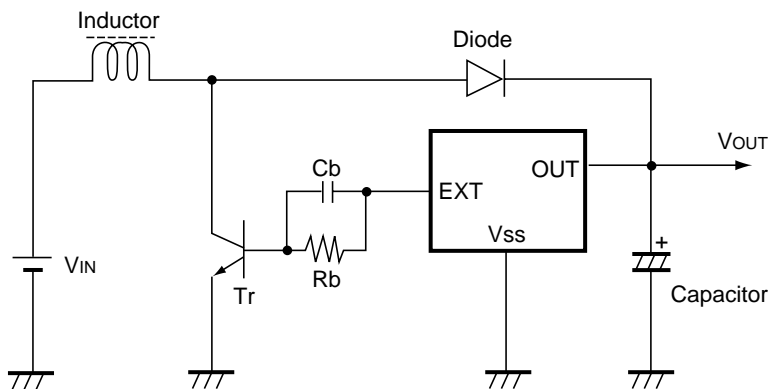

- Components Inductor (L) : 28 μ H (Troidal Core)
- Diode (D) : HRP22 (Hitachi, Schottky Type)
- Capacitor (CL) : 100 μ F (Tantalum Type)
- Transistor (Tr) : 2SD1628G
- Base Resistor (Rb) : 300 Ω
- Base Capacitor (Cb) : 0.01 μ F

FIG. 2

• RH5RI××3B

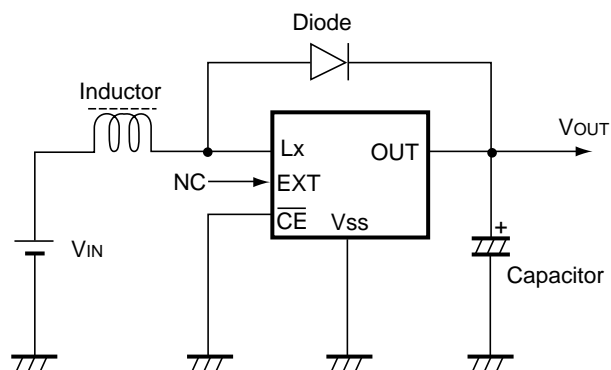

Components Inductor (L) : 82 μ H (Sumida Electric Co., Ltd.)
 Diode (D) : MA721 (Matsushita Electronics Corporation, Schottky Type)
 Capacitor (CL) : 22 μ F (Tantalum Type)

FIG. 3

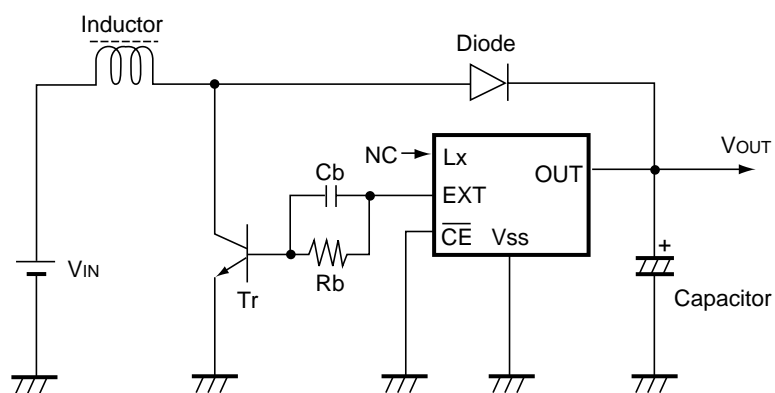

Components Inductor (L) : 28 μ H (Troidal Core)
 Diode (D) : HRP22 (Hitachi, Schottky Type)
 Capacitor (CL) : 100 μ F (Tantalum Type)
 Transistor (Tr) : 2SD1628G
 Base Resistor (Rb) : 300 Ω
 Base Capacitor (Cb) : 0.01 μ F

FIG. 4

• \overline{CE} pin Drive Circuit

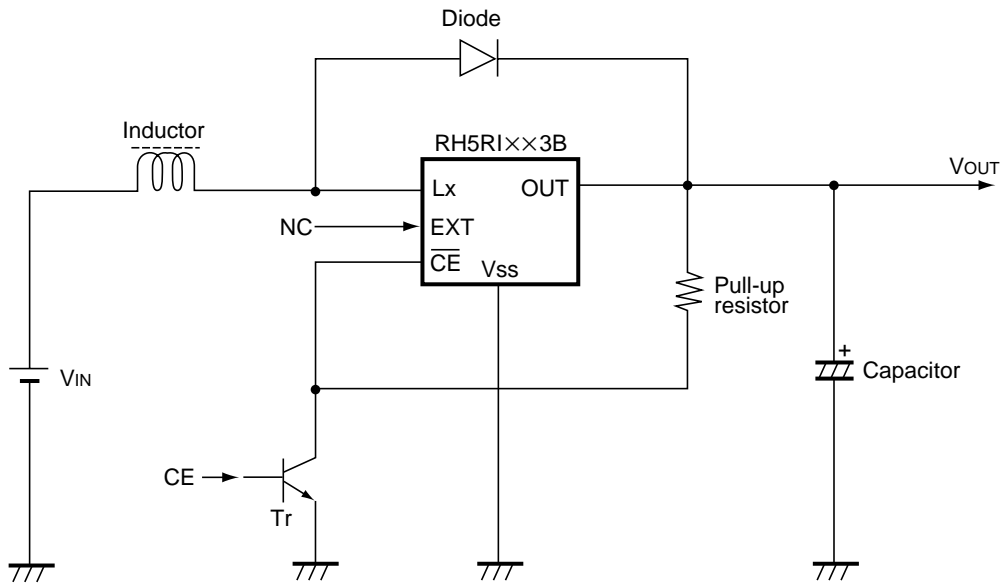
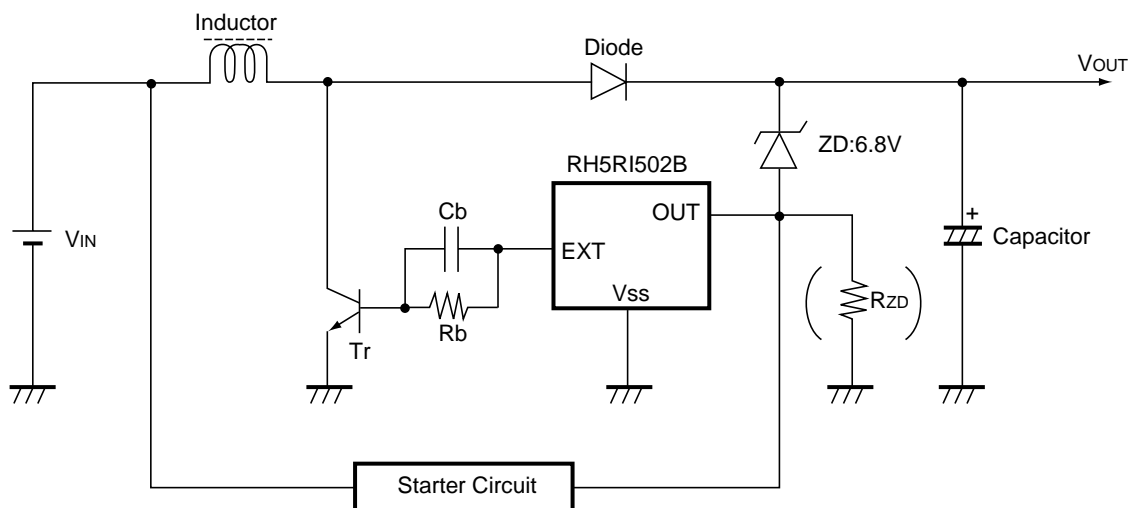

FIG. 5

APPLICATION CIRCUITS

• 12V Step-up Circuit



(Note) When the Output Current is small or the Output Voltage is unstable, use the R_{ZD} for flowing the bias current through the Zener diode ZD.

FIG. 6

• Step-down Circuit

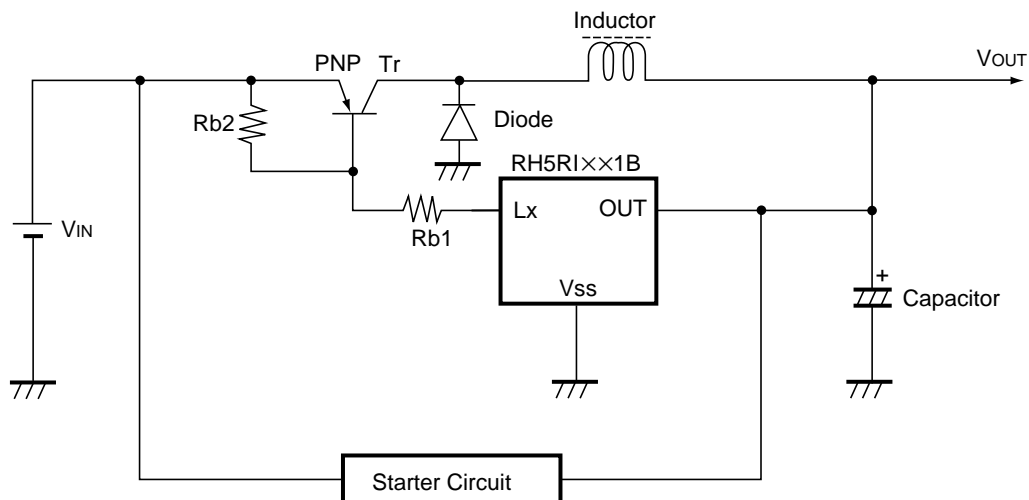

(Note) When the Lx pin Voltage is over the rating at the time PNP T_r is OFF, use a RH5RIx2B and drive the PNP T_r by the external NPN T_r .

FIG. 7

• Step-up/Step-down Circuit with Flyback

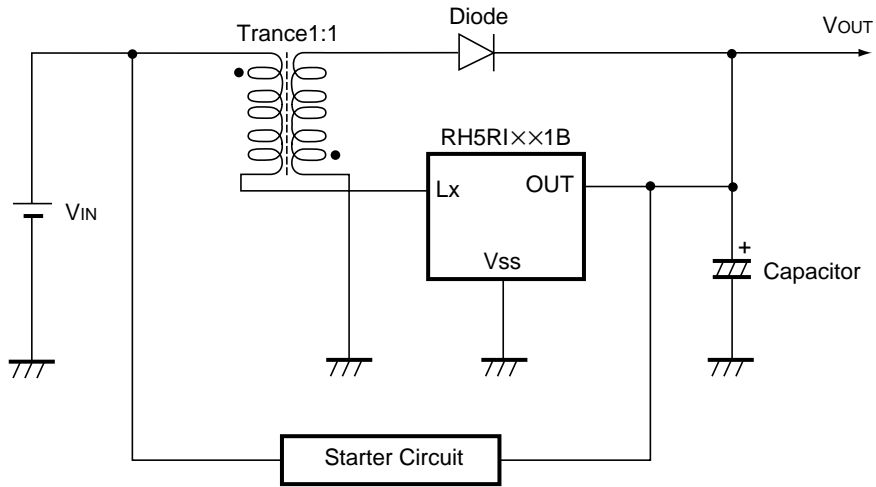

(Note) Use a RH5RIxx2B, depend on the Output Current.

FIG. 8

*The Starter Circuit is necessary for all above circuits.

1. For Step-up Circuit.

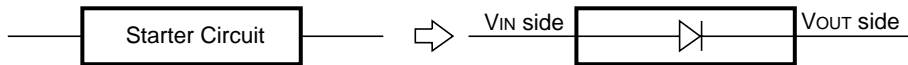

1. For Step-down and Step-up/Step-down Circuit.

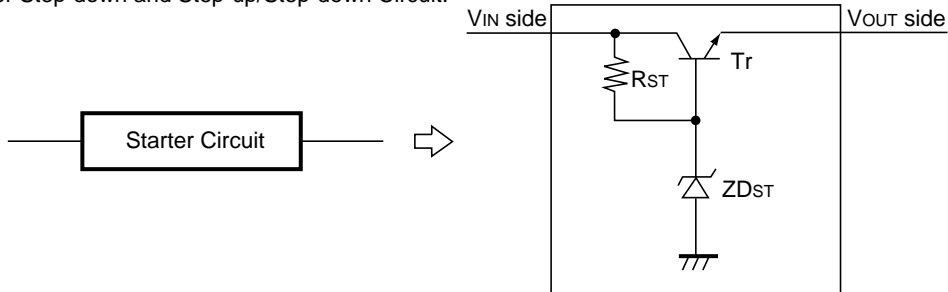

ZDst $2.5V \leq ZDst \leq$ Designation of Output Voltage
 Rst Input Bias Current of ZDst and Tr.
 (several kΩ to several hundreds kΩ)

APPLICATION HINTS

When using these ICs, be sure to take care of the following points :

- Set external components as close as possible to the IC and minimize the connection between the components and the IC. In particular, when an external component is connected to OUT Pin, make minimum connection with the capacitor.
- Make sufficient grounding. A large current flows through Vss Pin by switching. When the impedance of the Vss connection is high, the potential within the IC is varied by the switching current. This may result in unstable operation of the IC.
- Use capacitor with a capacity of 10 μ F or more, and with good high frequency characteristics such as tantalum capacitor. We recommend the use of a capacitor with an allowable voltage which is at least three times the output set voltage. This is because there may be the case where a spike-shaped high voltage is generated by the inductor when Lx transistor is turned off.
- Take the utmost care when choosing an inductor. Namely, choose such an inductor that has sufficiently small d.c. resistance and large allowable current, and hardly reaches magnetic saturation. When the inductance value of the inductor is small, there may be the case where ILX exceeds the absolute maximum ratings at the maximum load. Use an inductor with an appropriate inductance (refer to Selection of peripheral components).
- Use a diode of a Schottky type with high switching speed, and also take care of the rated current (refer to Selection of peripheral components).

The performance of power source circuits using these ICs largely depends upon the peripheral components. Take the utmost care in the selection of the peripheral components. In particular, design the peripheral circuits in such a manner that the values such as voltage, current and power of each component, PCB patterns and the IC do not exceed their respective rated values.