

■ BLOCK DIAGRAM

- R5421NxxxC

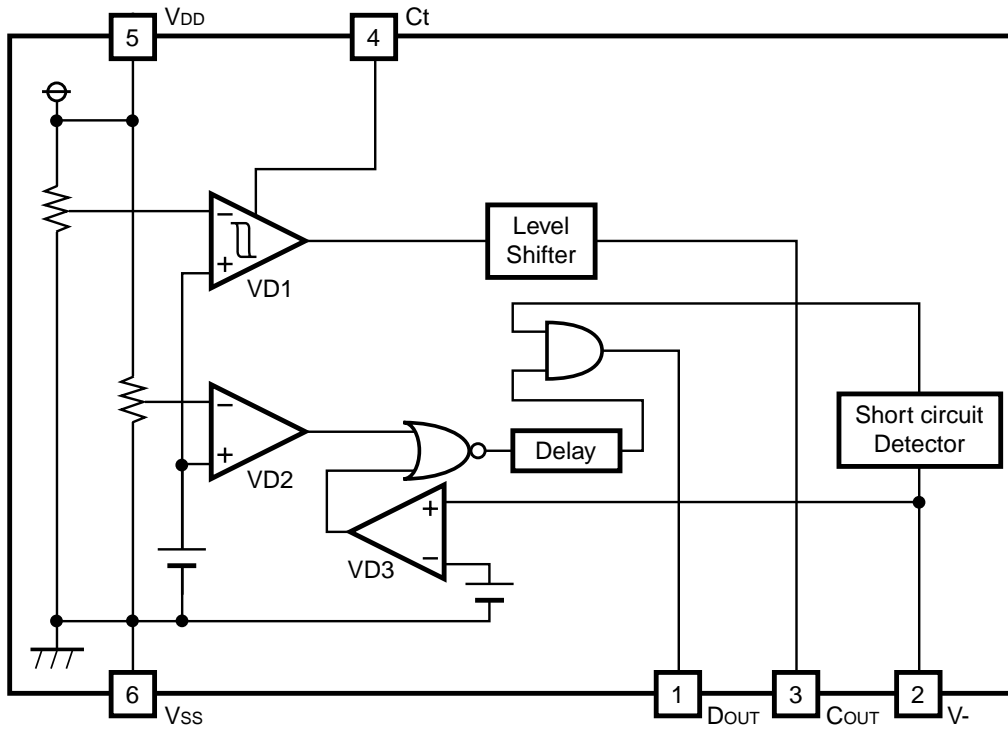

- R5421NxxxF

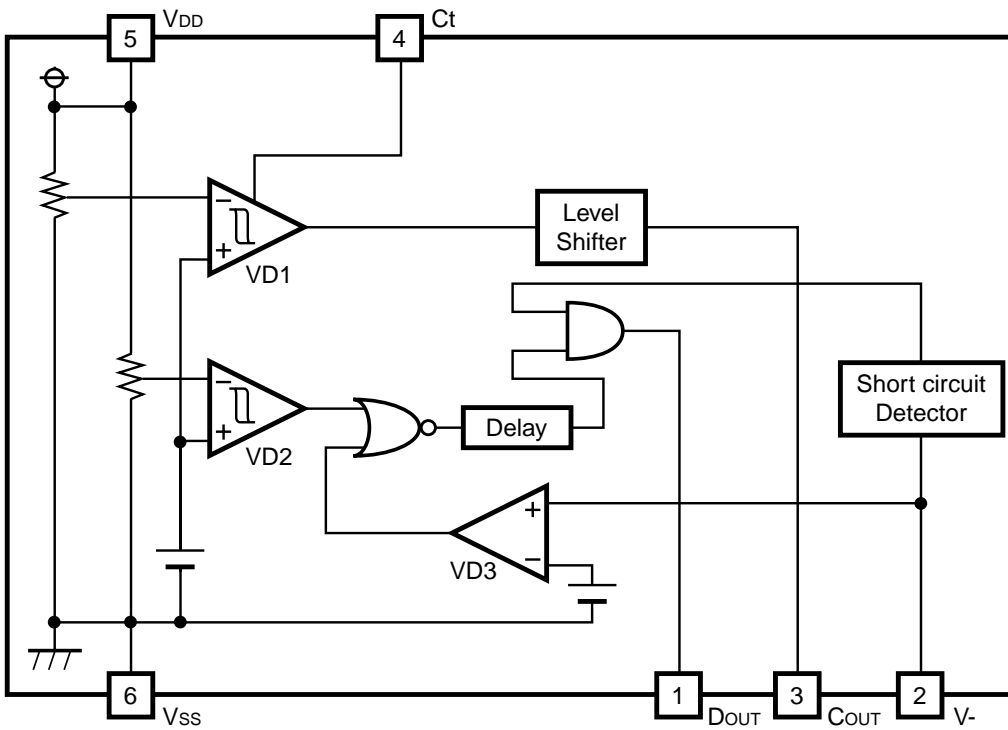

SELECTION GUIDE

In the R5421Nxxxx Series three of the input threshold for over-charge, over-discharge and excess current detectors can be designated.

Part Number is designated as follows:

R5421N XXXX-XX ←Part Number
 ↑ ↑ ↑
 a b c

Code	Description
a	Serial Number for the R5421N Series designating input threshold for over-charge, over-discharge and excess current detectors as well as hysteresis range for over-charge detector.
b	Designation of version symbols
c	Taping Type: TR (refer to Taping Specification)

PIN CONFIGURATION

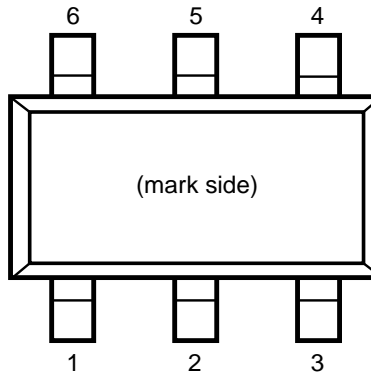

PIN DESCRIPTION

Pin No.	Symbol	Pin description
1	D _{OUT}	Output of over-discharge detection, CMOS output
2	V-	Pin for charger negative input
3	C _{OUT}	Output of over-charge detection, CMOS output
4	C _t	Pin for external capacitor setting output delay of VD1
5	V _{DD}	Power supply
6	V _{SS}	Ground

■ ABSOLUTE MAXIMUM RATINGS

$V_{SS}=0V$

Symbol	Item	Ratings	Unit
V_{DD}	Supply voltage	-0.3 to 12	V
V- V_{Ct}	Input Voltage		
	V - pin	$V_{DD} - 28$ to $V_{DD} + 0.3$	V
	Ct pin	$V_{SS} - 0.3$ to $V_{DD} + 0.3$	V
V_{COUT} V_{DOUT}	Output voltage		
	C_{OUT} pin	$V_{DD} - 28$ to $V_{DD} + 0.3$	V
	D_{OUT} pin	$V_{SS} - 0.3$ to $V_{DD} + 0.3$	V
P_D	Power dissipation	150	mW
T_{opt}	Operating temperature range	-40 to 85	°C
T_{stg}	Storage temperature range	-55 to 125	°C

ABSOLUTE MAXIMUM RATINGS

Absolute Maximum ratings are threshold limit values that must not be exceeded ever for an instant under any conditions. Moreover, such values for any two items must not be reached simultaneously. Operation above these absolute maximum ratings may cause degradation or permanent damage to the device. These are stress ratings only and do not necessarily imply functional operation below these limits.

■ ELECTRICAL CHARACTERISTIC

● R5421N111C

Top_t=25°C

Symbol	Item	Conditions	MIN.	TYP.	MAX.	Unit
V _{DD1}	Operating input voltage	Voltage defined as V _{DD} - V _{SS}	1.5		10	V
V _{St}	Minimum operating Voltage for 0V charging	Voltage defined as V _{DD} - V ₋ , V _{DD} - V _{SS} =0V			1.2	V
V _{DET1}	Over-charge threshold	Detect rising edge of supply voltage (Top _t =25°C) (Top _t =0 to 50°C)*Note	4.225 4.220	4.250 4.250	4.275 4.280	V V
V _{REL1}	Release voltage for over-charge detection		4.00	4.05	4.10	V
tV _{DET1}	Output delay of over-Charge	C3=0.01μF, V _{DD} =3.6V to 4.3V	60	75	90	ms
V _{DET2}	Over-discharge threshold	Detect falling edge of supply voltage	2.437	2.500	2.563	V
tV _{DET2}	Output delay of over-Discharge	V _{DD} =3.6V to 2.4V	7	10	13	ms
V _{DET3}	Excess current threshold	Detect rising edge of 'V-' pin voltage	0.17	0.20	0.23	V
tV _{DET3}	Output delay of excess Current	V _{DD} =3.0V	9	13	17	ms
V _{short}	Short protection voltage	V _{DD} =3.0V	V _{DD} -1.2	V _{DD} -0.9	V _{DD} -0.6	V
t _{short}	Output Delay of Short protection	V _{DD} =3.0V		5	50	μs
R _{short}	Reset resistance for Excess current protection	V _{DD} =3.6V, V ₋ =1.0V	50	100	150	kΩ
V _{ol1}	Nch ON voltage of C _{OUT}	I _{ol} =50μA, V _{DD} =4.4V		0.35	0.5	V
V _{oh1}	Pch ON voltage of C _{OUT}	I _{oh} =-50μA, V _{DD} =3.9V	3.4	3.7		V
V _{ol2}	Nch ON voltage of D _{OUT}	I _{ol} =50μA, V _{DD} =2.4V		0.2	0.5	V
V _{oh2}	Pch ON voltage of D _{OUT}	I _{oh} =-50μA, V _{DD} =3.9V	3.4	3.7		V
I _{DD}	Supply current	V _{DD} =3.9V, V ₋ =0V		3.0	6.0	μA
I _{standby}	Standby current	V _{DD} =2.0V		0.3	0.6	μA

*Note: Considering of variation in process parameters, we compensate for this characteristic related to temperature by laser-trim, however, this specification is guaranteed by design, not production tested.

● R5421N112C

Topt=25°C

Symbol	Item	Conditions	MIN.	TYP.	MAX.	Unit
V _{DD1}	Operating input voltage	Voltage defined as V _{DD} - V _{SS}	1.5		10	V
V _{st}	Minimum operating Voltage for 0V charging	Voltage defined as V _{DD} - V ₋ , V _{DD} - V _{SS} =0V			1.2	V
V _{DET1}	Over-charge threshold	Detect rising edge of supply Voltage Topt=25°C Topt=0 to 50°C*Note	4.325 4.320	4.350 4.350	4.375 4.380	V V
V _{REL1}	Release voltage for over-charge detection		4.100	4.150	4.200	V
tV _{DET1}	Output delay of over-Charge	C3=0.01μF, V _{DD} =3.6V to 4.4V	61	77	93	ms
V _{DET2}	Over-discharge threshold	Detect falling edge of supply Voltage	2.437	2.500	2.563	V
tV _{DET2}	Output delay of over-Discharge	V _{DD} =3.6V to 2.4V	7	10	13	ms
V _{DET3}	Excess current threshold	Detect rising edge of 'V-' pin Voltage	0.17	0.20	0.23	V
tV _{DET3}	Output delay of excess Current	V _{DD} =3.0V	9	13	17	ms
V _{short}	Short protection voltage	V _{DD} =3.0V	V _{DD} -1.2	V _{DD} -0.9	V _{DD} -0.6	V
t _{short}	Output Delay of Short protection	V _{DD} =3.0V		5	50	μs
R _{short}	Reset resistance for excess current protection	V _{DD} =3.6V, V ₋ =1.0V	50	100	150	kΩ
V _{ol1}	Nch ON voltage of C _{OUT}	I _{ol} =50μA, V _{DD} =4.4V		0.35	0.5	V
V _{oh1}	Pch ON voltage of C _{OUT}	I _{oh} =-50μA, V _{DD} =3.9V	3.4	3.7		V
V _{ol2}	Nch ON voltage of D _{OUT}	I _{ol} =50μA, V _{DD} =2.4V		0.2	0.5	V
V _{oh2}	Pch ON voltage of D _{OUT}	I _{oh} =-50μA, V _{DD} =3.9V	3.4	3.7		V
I _{DD}	Supply current	V _{DD} =3.9V, V ₋ =0V		3.0	6.0	μA
I _{standby}	Standby current	V _{DD} =2.0V		0.3	0.6	μA

*Note: Considering of variation in process parameters, we compensate for this characteristic related to temperature by laser-trim, however this specification is guaranteed by design, not production tested.

● R5421N151F

Topt=25°C

Symbol	Item	Conditions	MIN.	TYP.	MAX.	Unit
V _{DD1}	Operating input voltage	Voltage defined as V _{DD} - V _{SS}	1.5		10	V
V _{St}	Minimum operating Voltage for 0V charging	Voltage defined as V _{DD} - V ₋ , V _{DD} - V _{SS} =0V			1.2	V
V _{DET1}	Over-charge threshold	Detect rising edge of supply Voltage Topt=25°C Topt=0 to 50°C*Note	4.225 4.220	4.250 4.250	4.275 4.280	V V
V _{REL1}	Release voltage for over-charge detection		4.000	4.050	4.100	V
tV _{DET1}	Output delay of over-Charge	C3=0.01μF, V _{DD} =3.6V to 4.3V	60	75	90	ms
V _{DET2}	Over-discharge threshold	Detect falling edge of supply Voltage	2.437	2.500	2.563	V
tV _{DET2}	Output delay of over-Discharge	V _{DD} =3.6V to 2.4V	7	10	13	ms
V _{DET3}	Excess current threshold	Detect rising edge of 'V-' pin Voltage	0.17	0.20	0.23	V
tV _{DET3}	Output delay of excess Current	V _{DD} =3.0V	9	13	17	ms
V _{short}	Short protection voltage	V _{DD} =3.0V	V _{DD} -1.2	V _{DD} -0.9	V _{DD} -0.6	V
t _{short}	Output Delay of Short protection	V _{DD} =3.0V		5	50	μs
R _{short}	Reset resistance for excess current protection	V _{DD} =3.6V, V ₋ =1.0V	50	100	150	kΩ
V _{ol1}	Nch ON voltage of C _{OUT}	I _{ol} =50μA, V _{DD} =4.4V		0.35	0.5	V
V _{oh1}	Pch ON voltage of C _{OUT}	I _{oh} =-50μA, V _{DD} =3.9V	3.4	3.7		V
V _{ol2}	Nch ON voltage of D _{OUT}	I _{ol} =50μA, V _{DD} =2.2V		0.2	0.5	V
V _{oh2}	Pch ON voltage of D _{OUT}	I _{oh} =-50μA, V _{DD} =3.9V	3.4	3.7		V
I _{DD}	Supply current	V _{DD} =3.9V, V ₋ =0V		3.0	6.0	μA
I _{standby}	Standby current	V _{DD} =2.0V		1.0	2.0	μA

*Note: Considering of variation in process parameters, we compensate for this characteristic related to temperature by laser-trim, however, this specification is guaranteed by design, not production tested.

● R5421N152F

Topt=25°C

Symbol	Item	Conditions	MIN.	TYP.	MAX.	Unit
V _{DD1}	Operating input voltage	Voltage defined as V _{DD} - V _{SS}	1.5		10	V
V _{St}	Minimum operating Voltage for 0V charging	Voltage defined as V _{DD} - V ₋ , V _{DD} - V _{SS} =0V			1.2	V
V _{DET1}	Over-charge threshold	Detect rising edge of supply Voltage Topt=25°C Topt=0 to 50°C*Note	4.325 4.320	4.350 4.350	4.375 4.380	V V
V _{REL1}	Release voltage for over-charge detection		4.100	4.150	4.200	V
tV _{DET1}	Output delay of over-Charge	C3=0.01μF, V _{DD} =3.6V to 4.4V	61	77	93	ms
V _{DET2}	Over-discharge threshold	Detect falling edge of supply Voltage	2.437	2.500	2.563	V
tV _{DET2}	Output delay of over-Discharge	V _{DD} =3.6V to 2.4V	7	10	13	ms
V _{DET3}	Excess current threshold	Detect rising edge of 'V-' pin Voltage	0.17	0.20	0.23	V
tV _{DET3}	Output delay of excess Current	V _{DD} =3.0V	9	13	17	ms
V _{short}	Short protection voltage	V _{DD} =3.0V	V _{DD} -1.2	V _{DD} -0.9	V _{DD} -0.6	V
t _{short}	Output Delay of Short protection	V _{DD} =3.0V		5	50	μs
R _{short}	Reset resistance for excess current protection	V _{DD} =3.6V, V ₋ =1.0V	50	100	150	kΩ
V _{ol1}	Nch ON voltage of C _{OUT}	I _{ol} =50μA, V _{DD} =4.4V		0.35	0.5	V
V _{oh1}	Pch ON voltage of C _{OUT}	I _{oh} =-50μA, V _{DD} =3.9V	3.4	3.7		V
V _{ol2}	Nch ON voltage of D _{OUT}	I _{ol} =50μA, V _{DD} =2.2V		0.2	0.5	V
V _{oh2}	Pch ON voltage of D _{OUT}	I _{oh} =-50μA, V _{DD} =3.9V	3.4	3.7		V
I _{DD}	Supply current	V _{DD} =3.9V, V ₋ =0V		3.0	6.0	μA
I _{standby}	Standby current	V _{DD} =2.0V		1.0	2.0	μA

*Note: Considering of variation in process parameters, we compensate for this characteristic related to temperature by laser-trim, however, this specification is guaranteed by design, not production tested.

■ OPERATION

● VD1 / Over-Charge Detector in the 'C' version

The VD1 monitors V_{DD} pin voltage. When the V_{DD} voltage crosses over-charge detector threshold V_{DETI} from a low value to a value higher than the V_{DETI}, the VD1 can sense a over-charging and an external charge control Nch-MOS-FET turns to “OFF” with C_{OUT} pin being at “Low” level.

There can be two cases to reset the VD1 making the C_{OUT} pin level to “High” again after detecting over-charge. Resetting the VD1 can make charging system allowable to resumption of charging process.

The first case is in such conditions that a time when the V_{DD} voltage is coming down to a level lower than “V_{RELI}”.

While in the second case, connecting a kind of loading to V_{DD} after disconnecting a charger from the battery pack can make the VD1 resetting when the V_{DD} level is in between “V_{DETI}” and “V_{RELI}”.

After detecting over-charge with the V_{DD} voltage of higher than V_{DETI}, connecting system load to the battery pack makes load current allowable through parasitic diode of external charge control FET.

The C_{OUT} level would be High when the V_{DD} level is coming down to a level below the V_{DETI} by continuous drawing of load current.

An output delay time for over-charge detection can be set by external capacitor C3 connecting between the V_{SS} pin and Ct pin. The external capacitor can make a delay time from a moment detecting over-charge to a time output a signal which enables charge control FET turn to “OFF”.

When the V_{DD} level is going up to a higher level than V_{DETI} if the V_{DD} voltage would be back to a level lower than the V_{DETI} within a time period of the output delay time, VD1 would not output a signal for turning “OFF” of charge control FET.

The output delay time can be calculated as below:

$$t_{V_{DETI}[\text{sec}]} = (C3[\text{F}] \times (V_{DD}[\text{V}] - 0.7) / (0.48 \times 10^{-6}))$$

Note: T_{opt}=25°C V_{DD} value should be after over-charge detection.

A level shifter incorporated in a buffer driver for the C_{OUT} pin makes the “Low” level of C_{OUT} pin to the V_{SS} pin voltage and the “High” level of C_{OUT} pin is set to V_{DD} voltage with CMOS buffer.

● VD2 / Over-Discharge Detector

The VD2 is monitoring a V_{DD} pin voltage. When the V_{DD} voltage crosses the over-discharge detector threshold V_{DET2} from a high value to a value lower than the V_{DET2}, the VD2 can sense an over-discharging and the external discharge control Nch MOS FET turns to “OFF” with the D_{OUT} pin being at “Low” level.

To reset the VD2 with the D_{OUT} pin level being “H” again after detecting over-discharge it is necessary to connect a charger to the battery pack for R5421N_{XXX}C. When the V_{DD} voltage stays under over- discharge detector threshold V_{DET2} charge current can flow through parasitic diode of external discharge control MOS FET, then after the V_{DD} voltage comes up to a value larger than V_{DET2}, D_{OUT} becomes “H” and discharging process would be able to advance through ON state MOS FET for discharge control.

Connecting a charger to the battery pack makes the D_{OUT} level being “H” instantaneously when the V_{DD} voltage is higher than V_{DET2}.

Besides, for R5421N_{XXX}F, when a cell voltage reaches equal or more than over-discharge released voltage, or V_{REL2}, over-discharge condition can be also released

When a cell voltage equals to zero, connecting charger to the battery pack makes the system allowable to charge with higher charge voltage than V_{st}, 1.2V Max.

An output delay time for the over-discharge detection is fixed internally, t_{V_{DET2}}=10ms typ. at V_{DD}=2.4V. When the V_{DD} level is going down to a lower level than V_{DET2} if the V_{DD} voltage would be back to a level higher than the V_{DET2} within a time period of the output delay time, VD2 would not output a signal for turning “OFF” of discharge control FET.

After detection of an over-discharge by VD2, supply current would be reduced to typically 0.3μA(for R5421N_{XXX}C) or 1.0μA(for R5421N_{XXX}F) at V_{DD}=2.0V and into standby, only the charger detector is operating.

The output type of D_{OUT} pin is CMOS having “H” level of V_{DD} and “L” level of V_{SS}.

- VD3/Excess Current Detector, Short Circuit Protector

Both of the excess current detector and short circuit protector can work when both control FETs are in “ON” state. When the V- pin voltage is going up to a value between the short protection voltage V_{short}/V_{DD} and excess current threshold V_{DET3} , the excess current detector operates and further soaring of V- pin voltage higher than V_{short} makes the short circuit protector enabled. This leads the external discharge control Nch MOS FET turns to “OFF” with the D_{OUT} pin being at “Low” level.

An output delay time for the excess current detector is internally fixed, 13ms typ. at $V_{DD}=3.0V$.

A quick recovery of V- pin level from a value between V_{short} and V_{DET3} within the delay time keeps the discharge control FET staying “High” state.

When the short circuit protector is enabled ,the D_{OUT} would be Low and its delay time would be 5 μ s typ.

The V - pin has a built-in pulled down resistor ,typ.100k Ω , with connecting to the V_{SS} pin.

After an excess current or short circuit protection is detected, removing a cause of excess current or external short circuit makes an external discharge control FET to an “ON” state automatically with the V- pin level being down to the V_{SS} level through pulled down resistor built-in internally.

If V_{DD} voltage would be higher than V_{DET2} at a time when the excess current is detected the R5421NxxxC does not enter a standby mode, or otherwise in case of lower V_{DD} voltage than V_{DET2} would lead the R5421NxxxC into a standby.

After detecting short circuit the R5421NxxxC will not enter a standby mode.

■ TEST CIRCUITS

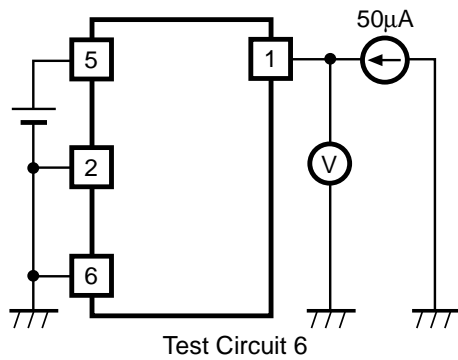
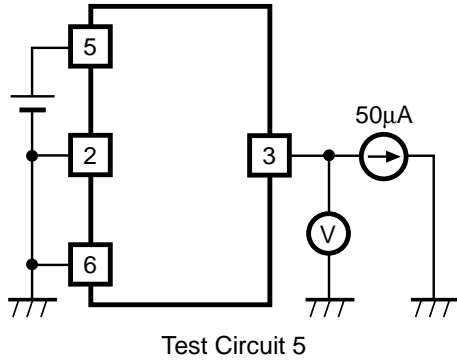
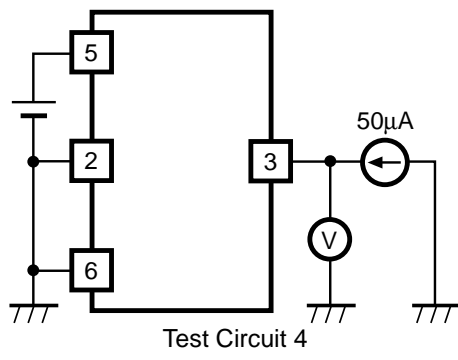
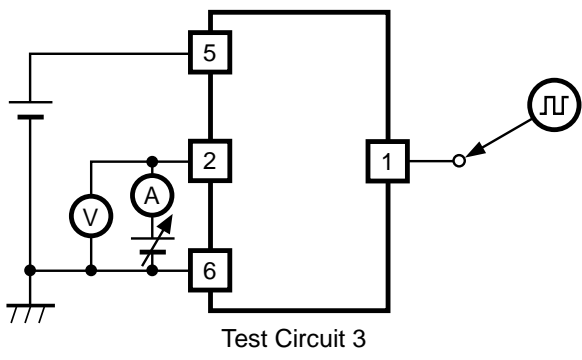
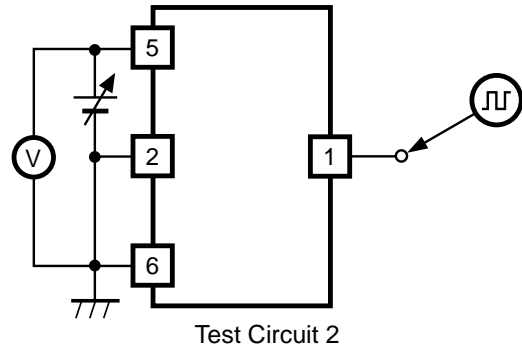
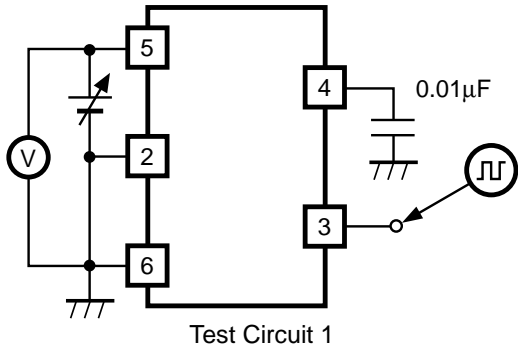

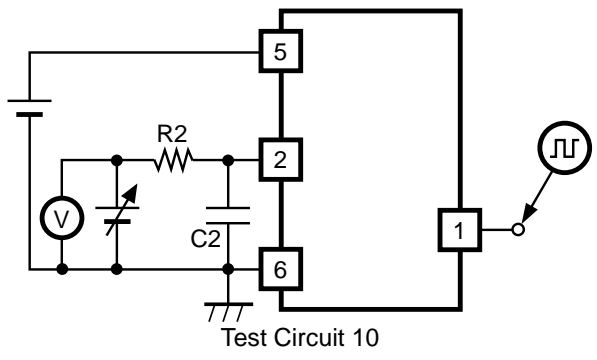
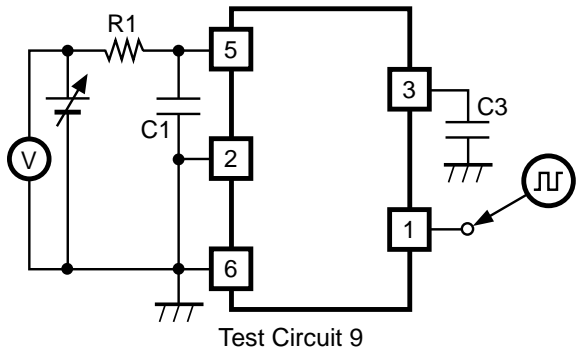
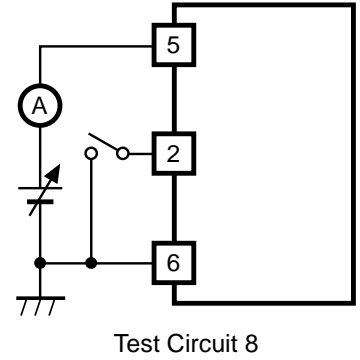
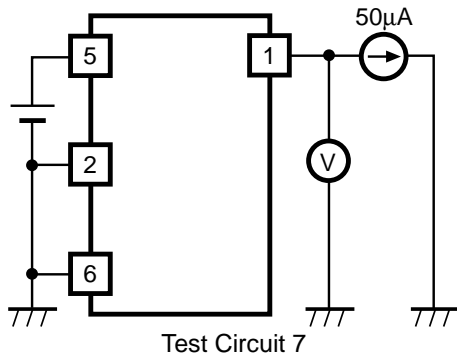

The typical characteristics were obtained by use of these test circuits.

- Test Circuit 1 : Typical Characteristics 1) 5) 7) 17)
- Test Circuit 2 : Typical Characteristics 2) 6) 8)
- Test Circuit 3 : Typical Characteristics 3) 4) 9) 10) 19)
- Test Circuit 4 : Typical Characteristics 13)
- Test Circuit 5 : Typical Characteristics 14)
- Test Circuit 6 : Typical Characteristics 15)
- Test Circuit 7 : Typical Characteristics 16)
- Test Circuit 8 : Typical Characteristics 11) 12)
- Test Circuit 9 : Typical Characteristics 21)
- Test Circuit 10 : Typical Characteristics 18) 20)

■ TYPICAL CHARACTERISTICS

1) Over-charge Threshold vs. Temperature

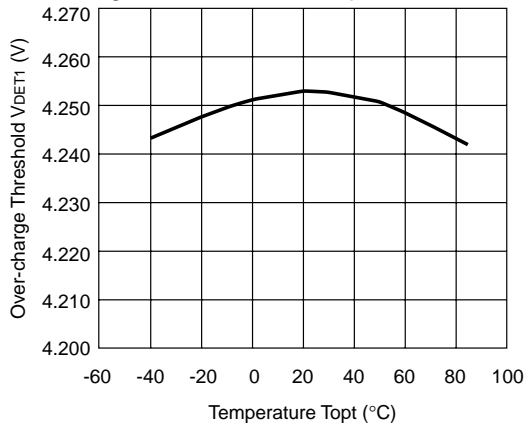

2) Over-discharge Threshold vs. Temperature

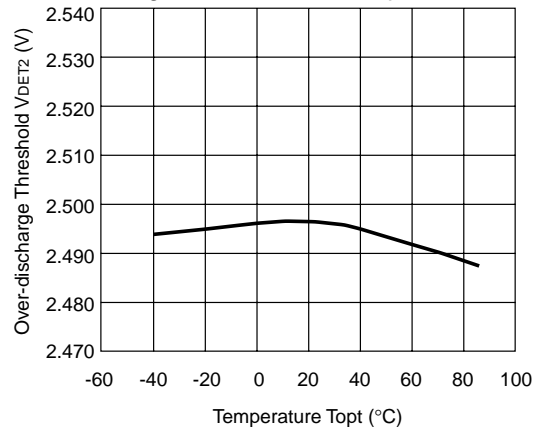

3) Excess Current Threshold vs. Temperature

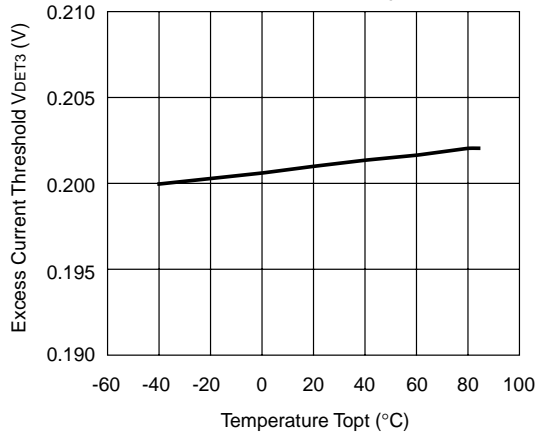

4) Short Circuit Protector Threshold vs. Temperature

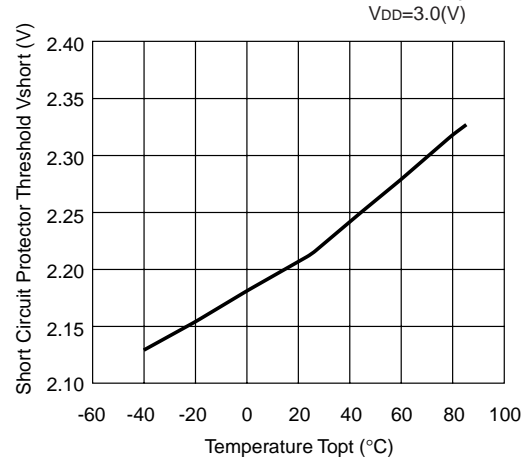

5) Over-charge Released Voltage vs. Temperature

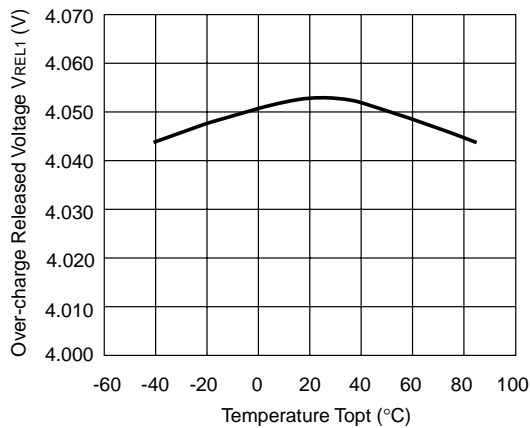

6) Over-discharge Released Voltage vs. Temperature (for R5421NxxxF)

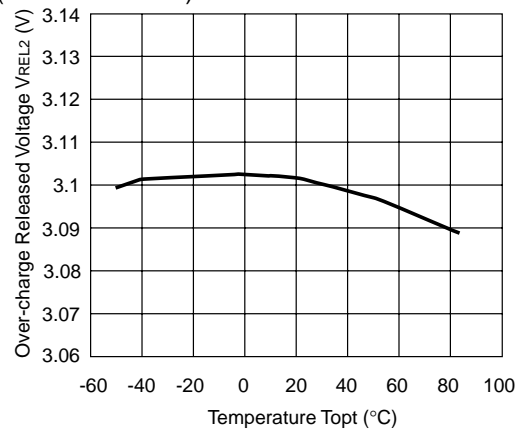

7) Output Delay of Over-charge vs. Temperature
 $C=0.01(\mu F)$ $V_{DD}=3.6(V)\rightarrow 4.3(V)$

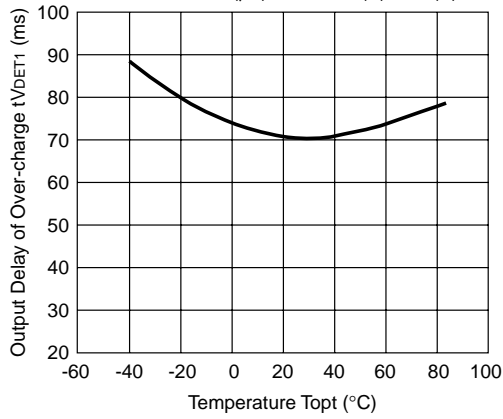

8) Output Delay of Over-discharge vs. Temperature
 $V_{DD}=3.6(V)\rightarrow 2.2(V)$

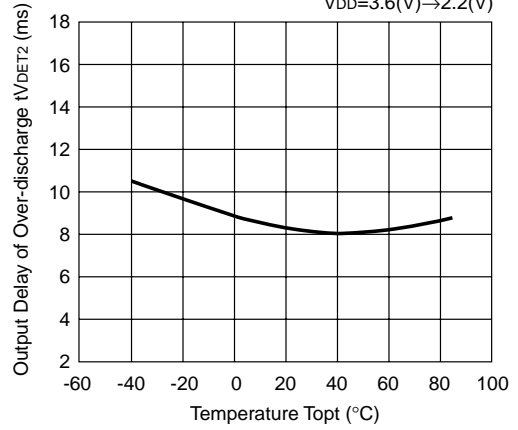

9) Output delay of Excess current vs. Temperature
 $V_{DD}=3.0(V)$

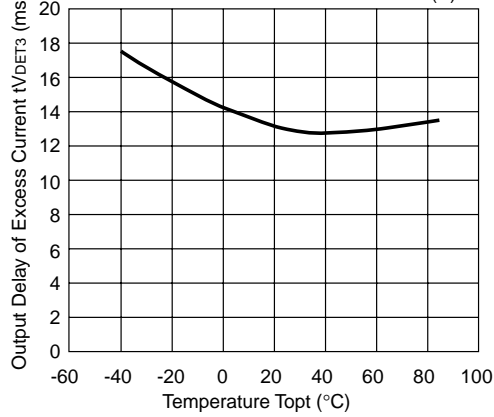

10) Output Delay of Short circuit protector vs. Temperature
 $V_{DD}=3.0(V)$

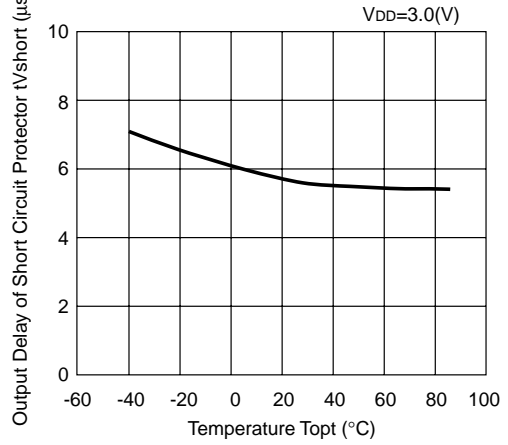

11) Supply Current vs. Temperature
 $V_{DD}=3.9(V)$ $V_{-}=0(V)$

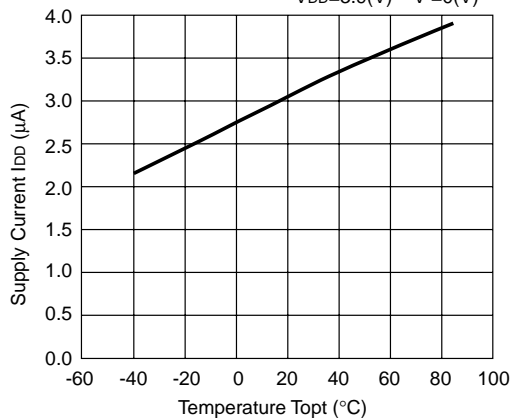

12) Supply Current vs. Temperature(for R5421NxxxC)

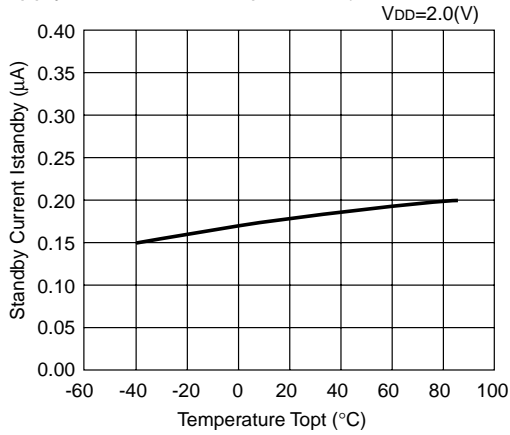

12) Standby Current vs. Temperature(for R5421NxxxF)

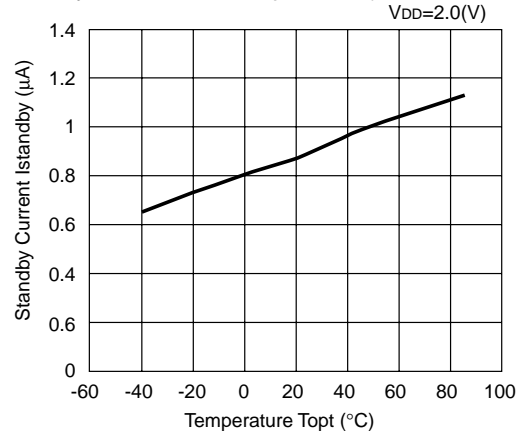

13) C_{OUT} Nch Driver ON Voltage vs. Temperature

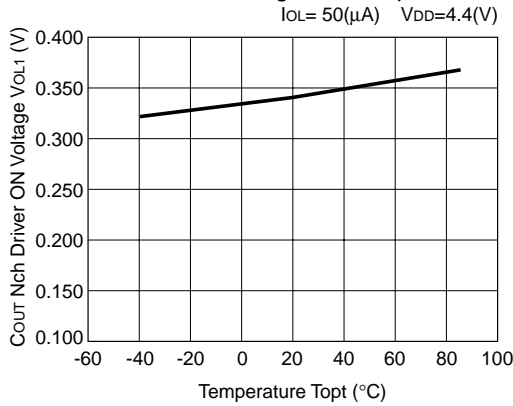

14) C_{OUT} Pch Driver ON Voltage vs. Temperature

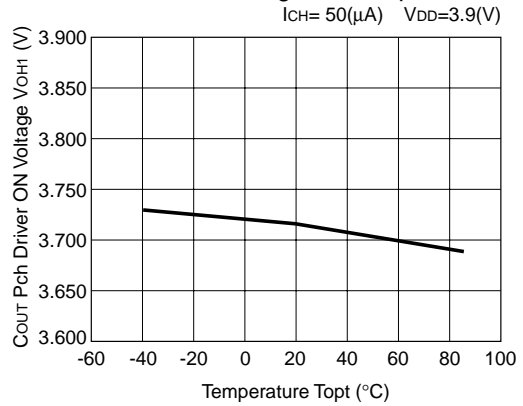

15) D_{OUT} Nch Driver ON Voltage vs. Temperature

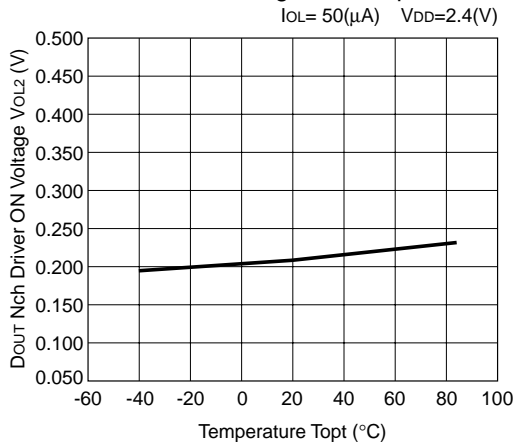

16) D_{OUT} Pch Driver ON Voltage vs. Temperature

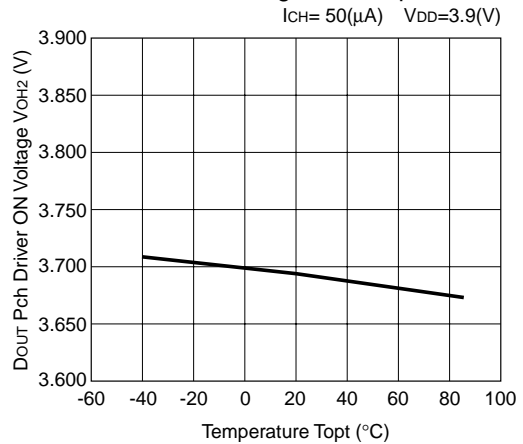

17) Output Delay of Over-charge vs. Capacitance C3
 $V_{DD}=3.8V \rightarrow 4.3V$ ($R1=100\Omega$, $C1=0.1\mu F$, $R2=1k\Omega$, $C2=0.1\mu F$)

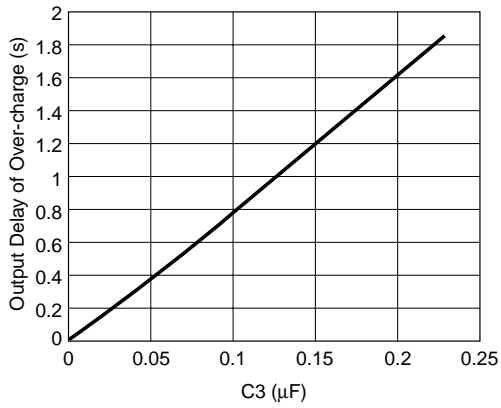

18) Output Delay of Short protection vs. Capacitance C2
 $R1=100\Omega$, $C1=0.1\mu F$, $C3=0.01\mu F$, $R2=1k\Omega$

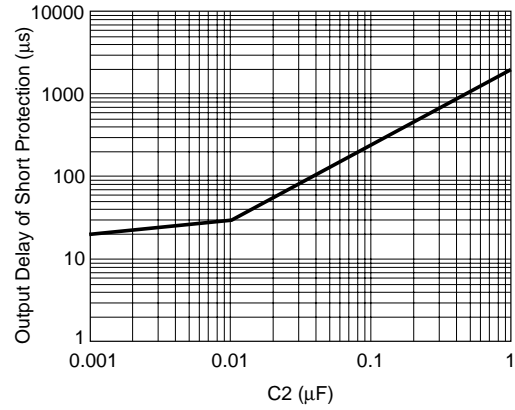

19) Output Delay of Excess Current vs. V_{DD}

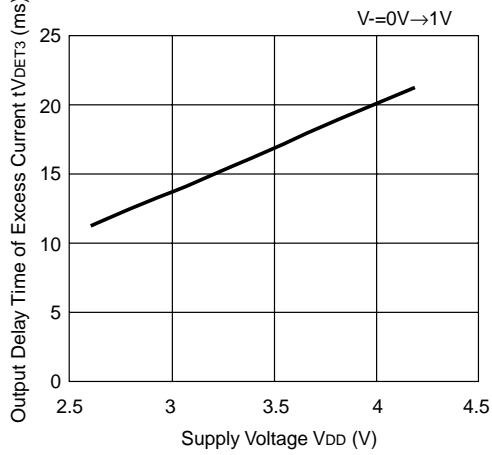

20) Excess Current Threshold vs. External Resistance R2

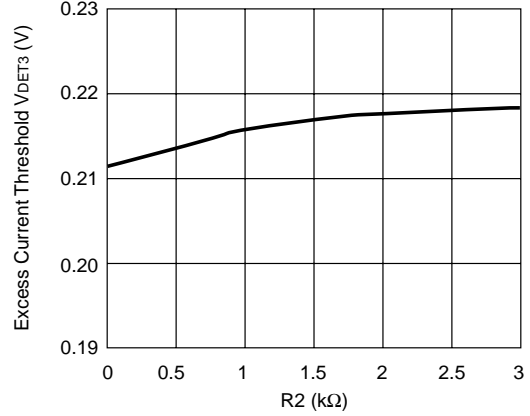

21) Over-charge Threshold vs. External Resistance R1

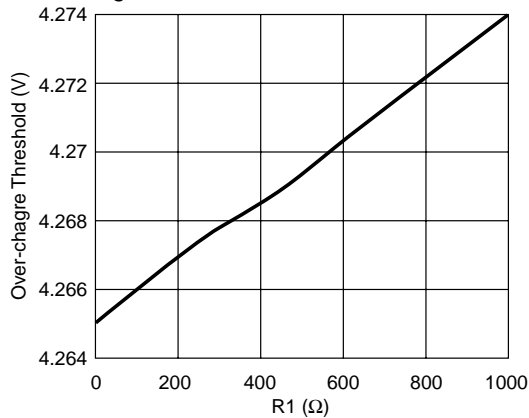

■ TYPICAL APPLICATION

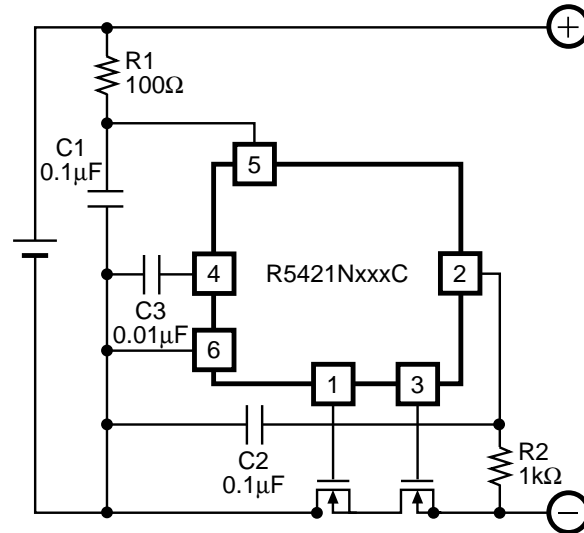

■ APPLICATION HINTS

R1 and C1 will stabilize a supply voltage to the R5421NxxxC. A recommended R1 value is less than 1kΩ.

A larger value of R1 leads higher detection voltage, makes some errors, because of shoot through current flowed in the R5421NxxxC.

R2 and C2 will stabilize a V- pin voltage. The resetting from over-discharge with connecting a charger possibly be disabled by larger value of R2. Recommended value is less than 1 kΩ.

After an over-charge detection even connecting battery pack to a system probably could not allow a system to draw load current by a larger R2C2 time constant in the C version.

Recommended C2 value is less than 1μF.

R1 and R2 can operate also as a part of current limit circuit against for setting cell reverse direction or for applying excess charging voltage to the R5421NxxxC, battery pack, while smaller

R1 and R2 may cause a power consumption over rating of power dissipation of the R5421NxxxC and a total of 'R1+R2' should be more than 1kΩ.

The time constants R1C1 or R2C2 must have a relations as below:

$$R1C1 \leq R2C2$$

Because in case that R1C1, time constant for VDD pin ,would be larger than R2C2, time constant for V- pin, then the R5421NxxxC might be into a standby mode after detecting excess current or short circuit current.

TIMING DIAGRAM

R5421NXXXX

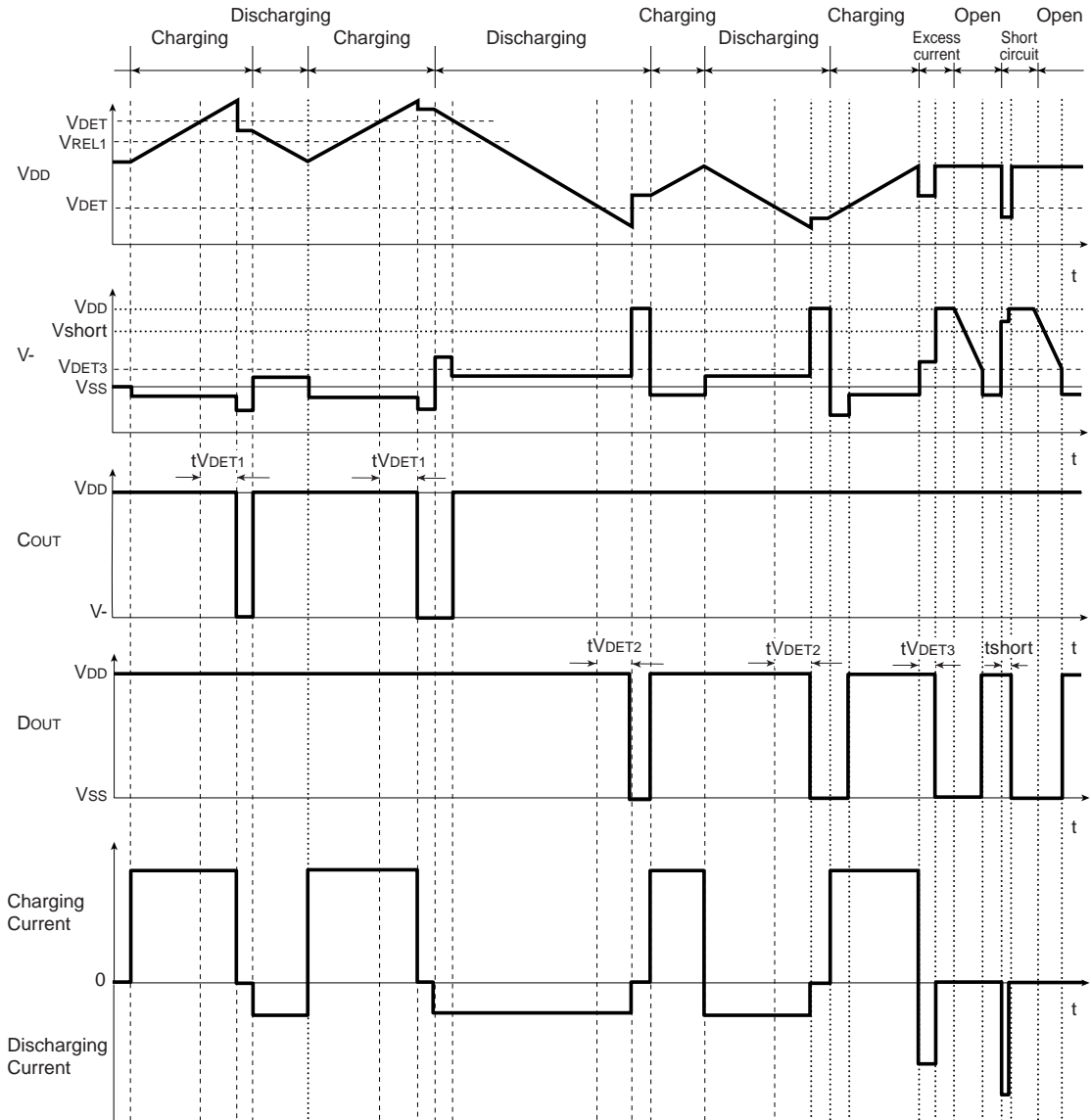

● R5421NXXXXF

