

## PWM Step-down DC/DC Converter with switch function

NO.EA-121-070824

### OUTLINE

The R5220x Series are CMOS-based PWM step-down DC/DC Converters with synchronous rectifier, low supply current and LDO mode.

DC/DC converter of the R5220x consists of an oscillator, a PWM control circuit, a reference voltage unit, an error amplifier, a soft-start circuit, protection circuits, a protection against miss operation under low voltage (UVLO), PWM-DC to DC converter / LDO alternative circuit, a chip enable circuit, and a driver transistor. A high efficiency step-down DC/DC converter can be easily composed of this IC with only a few kinds of external components, or an inductor and capacitors.

LDO of the R5220x consists of a voltage reference unit, an error amplifier, resistors for voltage setting, output current limit circuit, a driver transistor, and so on. The output voltage is fixed internally in the R5220x. The output voltage of the DC/DC converter and the LDO can be set independently.

PWM step-down DC/DC converter / LDO alternative circuit is active with Mode Pin of the R5220x Series. Thus, when the load current is small, the operation can be switching into the LDO operation from PWM operation by the logic of MODE pin and the consumption current of the IC itself will be small at light load current. As protection circuits, the current limit circuit which limits peak current of Lx at each clock cycle, and the latch type protection circuit which works if the term of the over-current condition keeps on a certain time in PWM mode. Latch-type protection circuit works to latch an internal driver with keeping it disable. To release the protection, after disable this IC with a chip enable circuit, enable it again, or restart this IC with power-on or make the supply voltage at UVLO detector threshold level or lower than UVLO.

### FEATURES

- Supply Current ..... Typ. 350 $\mu$ A (DC/DC), Typ. 5 $\mu$ A (VR)
- Standby Current ..... Typ. 0.1 $\mu$ A
- Built-in Driver ON Resistance ..... P-channel 0.5 $\Omega$ , N-channel 0.5 $\Omega$  (at  $V_{IN}=3.6V$ )
- Output Current ..... Min. 400mA (DC/DC), Min. 50mA (VR)
- Input Voltage ..... 2.8V to 5.5V (Absolute Input Maximum: 6.5V)
- Output Voltage ..... 1.0V to 3.3V
- Output Voltage Accuracy.....  $\pm 2.0\%$  ( $V_{OUT} \geq 1.5$ ),  $\pm 30mV$  ( $V_{OUT} < 1.5V$ )
- Oscillator Frequency (DC/DC) ..... Typ. 1.2MHz
- Package ..... SON-6, PLP2514-6
- Built-in Soft-start Function..... Typ. 0.2ms
- Latch-type Protection Function (Delay Time)..... Typ. 3.0ms
- Built-in fold-back protection circuit (DC/DC, VR)
- Ceramic Capacitor is recommended.

### APPLICATIONS

- Power source for portable equipment such as DSC, DVC, and communication equipment.



## PIN CONFIGURATIONS

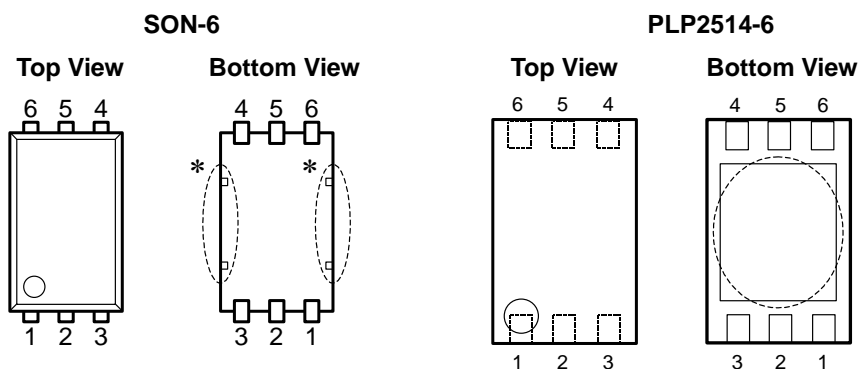

## PIN DESCRIPTIONS

Pin No	Symbol	Description
1	L <sub>x</sub>	L <sub>x</sub> Pin Voltage Supply Pin
2	GND	Ground Pin
3	MODE	Mode changer Pin (Refer to the selection guide above.)
4	CE	Chip Enable Pin (active with "H")
5	V <sub>OUT</sub>	Output Pin
6	V <sub>IN</sub>	Voltage Supply Pin

\* Tab in the  parts have GND level. (They are connected to the back side of this IC.)  
Do not connect to other wires or land patterns.

## ABSOLUTE MAXIMUM RATINGS

Symbol	Item	Rating	Unit
V <sub>IN</sub>	V <sub>IN</sub> Supply Voltage	6.5	V
V <sub>LX</sub>	L <sub>x</sub> Pin Voltage	-0.3 to V <sub>IN</sub> +0.3	V
V <sub>CE</sub>	CE Pin Input Voltage	-0.3 to 6.5	V
V <sub>MODE</sub>	MODE Pin Input Voltage	-0.3 to 6.5	V
V <sub>OUT</sub>	V <sub>OUT</sub> Pin Voltage	-0.3 to V <sub>IN</sub> +0.3	V
I <sub>LX</sub>	L <sub>x</sub> Pin Output Current	600	mA
I <sub>OUT</sub>	V <sub>OUT</sub> Pin Output Current	200	mA
P <sub>D</sub>	Power Dissipation (SON-6)*	500	mW
	Power Dissipation (PLP2514-6)*	730	
T <sub>opt</sub>	Operating Temperature Range	-40 to +85	°C
T <sub>stg</sub>	Storage Temperature Range	-55 to +125	°C

\*) For Power Dissipation, please refer to PACKAGE INFORMATION to be described.

## ELECTRICAL CHARACTERISTICS

## • R5220xxxxA

T<sub>opt</sub>=25°C

Symbol	Item	Conditions	Min.	Typ.	Max.	Unit
V <sub>IN</sub>	Operating Input Voltage		2.8		5.5	V
I <sub>SS1</sub>	Supply Current 1 (Standby mode)	V <sub>IN</sub> =V <sub>OUT1</sub> +1.0V, V <sub>CE</sub> =GND, V <sub>MODE</sub> =GND or V <sub>IN</sub> V <sub>OUT1</sub> :DC/DC Set V <sub>OUT</sub>		0.1	1.0	μA
I <sub>SS2</sub>	Supply Current 2 (Power Save mode)	V <sub>IN</sub> =V <sub>CE</sub> =V <sub>OUT2</sub> +1.0V, V <sub>MODE</sub> =GND V <sub>OUT2</sub> :VR Set V <sub>OUT</sub> , I <sub>OUT</sub> =0mA		5	10	μA
I <sub>SS3</sub>	Supply Current 3	V <sub>IN</sub> =V <sub>CE</sub> =V <sub>MODE</sub> =3.6V		350	450	μA

## DC/DC Part

T<sub>opt</sub>=25°C

Symbol	Item	Conditions	Min.	Typ.	Max.	Unit
V <sub>OUT1</sub>	Output Voltage	V <sub>IN</sub> =3.6V I <sub>OUT</sub> =50mA	V <sub>OUT1</sub> ≥ 1.5 ×0.98 V <sub>OUT1</sub> < 1.5 -0.03		×1.02 +0.03	V
f <sub>osc</sub>	Oscillator Frequency	V <sub>IN</sub> =3.6V	0.96	1.20	1.44	MHz
T <sub>START</sub>	Soft-start Time	V <sub>IN</sub> =3.6V	V <sub>OUT1</sub> < 1.5 V <sub>OUT1</sub> ≥ 1.5	0.15 0.20	0.30 0.35	ms
R <sub>ONP</sub>	ON Resistance of Pch Transistor	V <sub>IN</sub> =3.6V, I <sub>LX</sub> =-100mA		0.5		Ω
R <sub>ONN</sub>	ON Resistance of Nch Transistor	V <sub>IN</sub> =3.6V, I <sub>LX</sub> =-100mA		0.5		Ω
I <sub>LXLEAK</sub>	Lx Leakage Current	V <sub>IN</sub> =5.5V, V <sub>CE</sub> =0V, L <sub>X</sub> =5.5V/0V	-1.0		1.0	μA
ΔV <sub>OUT</sub> / ΔT <sub>opt</sub>	Output Voltage Temperature Coefficient	-40°C ≤ T <sub>opt</sub> ≤ 85°C		±150		ppm/°C
Maxduty	Oscillator Maximum Duty Cycle	V <sub>OUT</sub> =0V	100			%
I <sub>LXlim</sub>	Lx Current Limit	V <sub>IN</sub> =3.6V	500	800		mA
T <sub>prot</sub>	Protection Delay Circuit	V <sub>IN</sub> =3.6V	1.0	3.0	7.0	ms
V <sub>UVLO1</sub>	UVLO Threshold Voltage	V <sub>IN</sub> =V <sub>CE</sub> =V <sub>MODE</sub> , V <sub>OUT</sub> =0V	2.00	2.35	2.75	V
V <sub>UVLO2</sub>	UVLO Released Voltage	V <sub>IN</sub> =V <sub>CE</sub> =V <sub>MODE</sub> , V <sub>OUT</sub> =0V	2.05	2.45	2.80	V
V <sub>MODEH</sub>	MODE "H" Input Voltage		1.0			V
V <sub>MODEL</sub>	MODE "L" Input Voltage		0		0.3	V

## VR Part

T<sub>opt</sub>=25°C

Symbol	Item	Conditions	Min.	Typ.	Max.	Unit
V <sub>OUT2</sub>	Output Voltage	V <sub>IN</sub> =V <sub>OUT2</sub> +1.0V I <sub>OUT</sub> =10mA	V <sub>OUT2</sub> ≥ 1.5 ×0.98 V <sub>OUT2</sub> < 1.5 -0.03		×1.02 +0.03	V
I <sub>OUT</sub>	Output Current	V <sub>IN</sub> =V <sub>OUT2</sub> +1.0V	50			mA
ΔV <sub>OUT2</sub> / ΔI <sub>OUT</sub>	Load Regulation	V <sub>IN</sub> =V <sub>OUT2</sub> +1.0V 10μA ≤ I <sub>OUT</sub> ≤ 25mA	V <sub>OUT2</sub> < 2.3 2.3 ≤ V <sub>OUT2</sub> < 3.0 V <sub>OUT2</sub> ≥ 3.0	15 25 35	40 50 65	mV
V <sub>DIF</sub>	Dropout Voltage	I <sub>OUT</sub> =50mA	V <sub>OUT2</sub> < 1.8 V <sub>OUT2</sub> ≥ 1.8	0.7 0.3		V
ΔV <sub>OUT2</sub> / ΔV <sub>IN</sub>	Line Regulation	2.8V ≤ V <sub>IN</sub> ≤ 5.5V I <sub>OUT</sub> =25mA V <sub>OUT2</sub> +0.5V ≤ V <sub>IN</sub> ≤ 5.5V I <sub>OUT</sub> =25mA	V <sub>OUT2</sub> < 2.3 V <sub>OUT2</sub> ≥ 2.3		0.2	%/V
RR	Ripple Rejection	Refer to Typical Characteristics				dB
ΔV <sub>OUT</sub> / ΔT <sub>opt</sub>	Output Voltage Temperature Coefficient	I <sub>OUT</sub> =30mA, -40°C ≤ T <sub>opt</sub> ≤ 85°C		±100		ppm/°C
I <sub>lim</sub>	Short Current Limit	V <sub>OUT</sub> =0V		60		mA
I <sub>PDC</sub>	CE pull-down current		0.12	0.40	0.70	μA
V <sub>CEH</sub>	CE "H" Input Voltage		1.0			V
V <sub>CEL</sub>	CE "L" Input Voltage		0		0.3	V

## ● R5220xxxxB

T<sub>opt</sub>=25°C

Symbol	Item	Conditions	Min.	Typ.	Max.	Unit
V <sub>IN</sub>	Operating Input Voltage		2.8		5.5	V
I <sub>SS1</sub>	Supply Current 1 (Standby mode)	V <sub>IN</sub> =V <sub>OUT1</sub> +1.0V, V <sub>CE</sub> =GND, V <sub>MODE</sub> =GND or V <sub>IN</sub> V <sub>OUT1</sub> :DC/DC Set V <sub>OUT</sub>		0.1	1.0	μA
I <sub>SS2</sub>	Supply Current 2 (Power Save mode)	V <sub>IN</sub> =V <sub>CE</sub> =V <sub>MODE</sub> =V <sub>OUT2</sub> +1.0V, V <sub>OUT2</sub> :VR Set V <sub>OUT</sub> , I <sub>OUT</sub> =0mA		5	10	μA
I <sub>SS3</sub>	Supply Current 3	V <sub>IN</sub> =V <sub>CE</sub> =3.6V, V <sub>MODE</sub> =GND		350	450	μA

## DC/DC Part

T<sub>opt</sub>=25°C

Symbol	Item	Conditions	Min.	Typ.	Max.	Unit
V <sub>OUT1</sub>	Output Voltage	V <sub>IN</sub> =3.6V I <sub>OUT</sub> =50mA	V <sub>OUT1</sub> ≥ 1.5 ×0.98 V <sub>OUT1</sub> < 1.5 -0.03		×1.02 +0.03	V
f <sub>osc</sub>	Oscillator Frequency	V <sub>IN</sub> =V <sub>SET1</sub> +1.5V	0.96	1.20	1.44	MHz
T <sub>START</sub>	Soft-start Time	V <sub>IN</sub> =3.6V	V <sub>OUT1</sub> < 1.5 V <sub>OUT1</sub> ≥ 1.5	0.15 0.20	0.30 0.35	ms
R <sub>ONP</sub>	ON Resistance of Pch Transistor	V <sub>IN</sub> =3.6V, I <sub>LX</sub> =-100mA		0.5		Ω
R <sub>ONN</sub>	ON Resistance of Nch Transistor	V <sub>IN</sub> =3.6V, I <sub>LX</sub> =-100mA		0.5		Ω
I <sub>LXLEAK</sub>	Lx Leakage Current	V <sub>IN</sub> =5.5V, V <sub>CE</sub> =0V, I <sub>LX</sub> =5.5V/0V	-1.0		1.0	μA
ΔV <sub>OUT</sub> / ΔT <sub>opt</sub>	Output Voltage Temperature Coefficient	-40°C ≤ T <sub>opt</sub> ≤ 85°C		±150		ppm/°C
Maxduty	Oscillator Maximum Duty Cycle	V <sub>OUT</sub> =0V	100			%
I <sub>LXlim</sub>	Lx Current Limit	V <sub>IN</sub> =3.6V	500	800		mA
T <sub>prot</sub>	Protection Delay Circuit	V <sub>IN</sub> =3.6V	1.0	3.0	7.0	ms
V <sub>UVLO1</sub>	UVLO Threshold Voltage	V <sub>CE</sub> =V <sub>IN</sub> , V <sub>MODE</sub> =GND, V <sub>OUT</sub> =0V	2.00	2.35	2.75	V
V <sub>UVLO2</sub>	UVLO Released Voltage	V <sub>CE</sub> =V <sub>IN</sub> , V <sub>MODE</sub> =GND, V <sub>OUT</sub> =0V	2.05	2.45	2.80	V
V <sub>MODEH</sub>	MODE "H" Input Voltage		1.0			V
V <sub>MODEL</sub>	MODE "L" Input Voltage		0		0.3	V

## VR Part

T<sub>opt</sub>=25°C

Symbol	Item	Conditions	Min.	Typ.	Max.	Unit
V <sub>OUT2</sub>	Output Voltage	V <sub>IN</sub> =V <sub>OUT2</sub> +1.0V I <sub>OUT</sub> =10mA	V <sub>OUT2</sub> ≥ 1.5 ×0.98 V <sub>OUT2</sub> < 1.5 -0.03		×1.02 +0.03	V
I <sub>OUT</sub>	Output Current	V <sub>IN</sub> =V <sub>OUT2</sub> +1.0V	50			mA
ΔV <sub>OUT2</sub> / ΔI <sub>OUT</sub>	Load Regulation	V <sub>IN</sub> =V <sub>OUT2</sub> +1.0V 10μA ≤ I <sub>OUT</sub> ≤ 25mA	V <sub>OUT2</sub> < 2.3 2.3 ≤ V <sub>OUT2</sub> < 3.0 V <sub>OUT2</sub> ≥ 3.0	15 25 35	40 50 65	mV
V <sub>DIF</sub>	Dropout Voltage	I <sub>OUT</sub> =50mA	V <sub>OUT2</sub> < 1.8V V <sub>OUT2</sub> ≥ 1.8V	0.7 0.3		V
ΔV <sub>OUT2</sub> / ΔV <sub>IN</sub>	Line Regulation	2.8V ≤ V <sub>IN</sub> ≤ 5.5V I <sub>OUT</sub> =25mA V <sub>OUT2</sub> +0.5V ≤ V <sub>IN</sub> ≤ 5.5V I <sub>OUT</sub> =25mA	V <sub>OUT2</sub> < 2.3V V <sub>OUT2</sub> ≥ 2.3V		0.2	%/V
RR	Ripple Rejection	Refer to Typical Characteristics				dB
ΔV <sub>OUT</sub> / ΔT <sub>opt</sub>	Output Voltage Temperature Coefficient	I <sub>OUT</sub> =30mA, -40°C ≤ T <sub>opt</sub> ≤ 85°C		±100		ppm/°C
I <sub>lim</sub>	Short Current Limit	V <sub>OUT</sub> =0V		60		mA
I <sub>PDC</sub>	CE pull-down current		0.12	0.40	0.70	μA
V <sub>CEH</sub>	CE "H" Input Voltage		1.0			V
V <sub>CEL</sub>	CE "L" Input Voltage		0		0.3	V

## TYPICAL APPLICATION

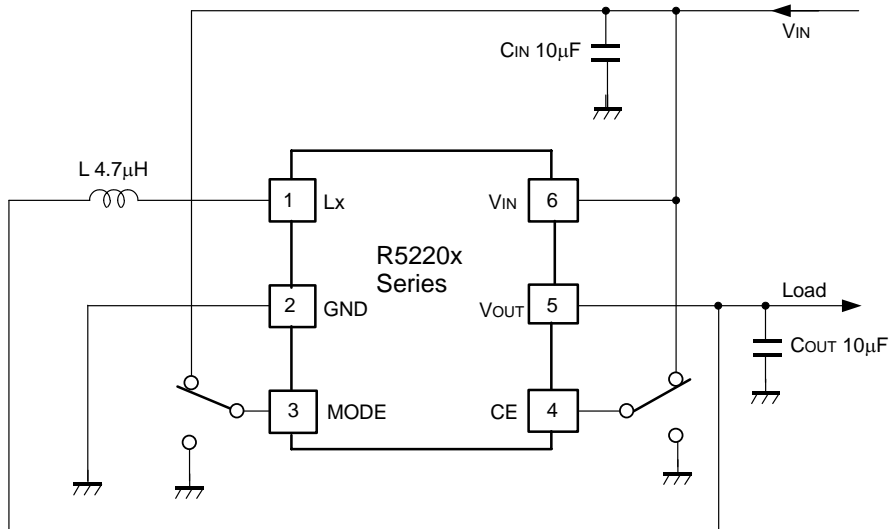

### Parts Recommendation

$C_{IN}$	10 $\mu$ F Ceramic Capacitor C2012JB0J106K (TDK)
$C_{OUT}$	10 $\mu$ F Ceramic Capacitor C2012JB0J106K (TDK)
L	4.7 $\mu$ H VLP5610-4R7(TDK)

## External Components

- Set external components such as an inductor,  $C_{IN}$ ,  $C_{OUT}$  as close as possible to the IC, in particular, minimize the wiring to  $V_{IN}$  pin and GND pin. If  $V_{DD}$  line or GND line's impedance is high, the internal voltage level of the IC may fluctuate and the operation may be unstable. Make GND line and  $V_{DD}$  line sufficient. Through the  $V_{DD}$  line, the GND line, the inductor, Lx pin, and  $V_{OUT}$  line, a large current caused by switching may flow, therefore, those lines should be sufficient and avoid the cross talk with other sensitive lines. Use the individual line from the  $V_{OUT}$  pin of the IC for the inductor and the capacitor and load.
- Use a low ESR ceramic capacitor  $C_{OUT}/C_{IN}$  with a capacity of 10 $\mu$ F or more.
- Select an inductor with an inductance range from 4.7 $\mu$ H to 10 $\mu$ H. The internal phase compensation is secured with these inductance values and  $C_{OUT}$  value. Choose the inductor with a low DC resistance and enough permissible current and hard to reach magnetic saturation. In terms of inductance value, choose the appropriate value with considering the conditions of the input voltage range and the output voltage, and load current. If the inductance value is too small and the load current is large, the peak current of Lx may reach the Lx current limit, and the protection against over-current may work.
- The protection circuit against over-current is affected by the self-heating and the heat radiation environment. Therefore evaluate under the considerable environment of the application.

The performance of power source circuits using these ICs extremely depends upon the peripheral circuits. Pay attention in the selection of the peripheral circuits. In particular, design the peripheral circuits in a way that the values such as voltage, current, and power of each component, PCB patterns and the IC do not exceed their respected rated values.

## OPERATION of step-down DC/DC converter and Output Current

The step-down DC/DC converter charges energy in the inductor when  $L_x$  transistor is ON, and discharges the energy from the inductor when  $L_x$  transistor is OFF and controls with less energy loss, so that a lower output voltage than the input voltage is obtained. The operation will be explained with reference to the following diagrams:

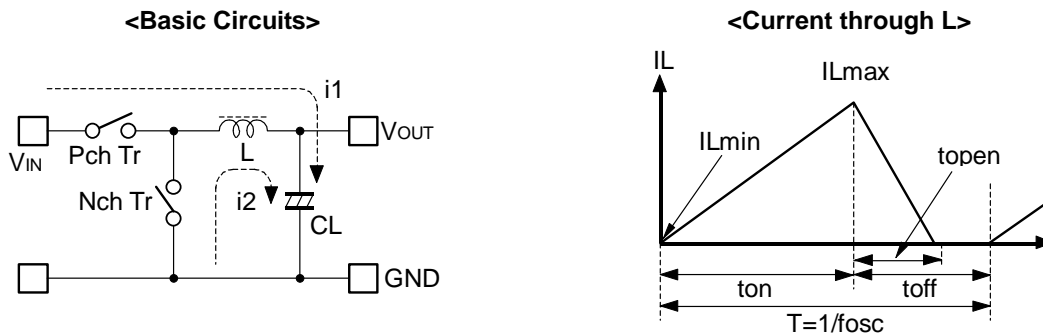

- Step 1: P-channel Tr. turns on and current  $I_L (=i_1)$  flows, and energy is charged into CL. At this moment,  $I_L$  increases from  $I_{Lmin} (=0)$  to reach  $I_{Lmax}$  in proportion to the on-time period ( $t_{on}$ ) of P-channel Tr.
- Step 2: When P-channel Tr. turns off, Synchronous rectifier N-channel Tr. turns on in order that L maintains  $I_L$  at  $I_{Lmax}$ , and current  $I_L (=i_2)$  flows.
- Step 3:  $I_L (=i_2)$  decreases gradually and reaches  $I_L = I_{Lmin} = 0$  after a time period of  $t_{open}$ , and N-channel Tr. Turns off. Provided that in the continuous mode, next cycle starts before  $I_L$  becomes to 0 because  $t_{off}$  time is not enough. In this case,  $I_L$  value increases from this  $I_{Lmin} (>0)$ .

In the case of PWM control system, the output voltage is maintained by controlling the on-time period ( $t_{on}$ ), with the oscillator frequency ( $f_{osc}$ ) being maintained constant.

The maximum value ( $I_{Lmax}$ ) and the minimum value ( $I_{Lmin}$ ) of the current flowing through the inductor are the same as those when P-channel Tr. turns on and off.

The difference between  $I_{Lmax}$  and  $I_{Lmin}$ , which is represented by  $\Delta I$ ;

$$\Delta I = I_{Lmax} - I_{Lmin} = V_{OUT} \times t_{open} / L = (V_{IN} - V_{OUT}) \times t_{on} / L \dots \dots \dots \text{Equation 1}$$

wherein,  $T = 1/f_{osc} = t_{on} + t_{off}$

$$\text{duty (\%)} = t_{on} / T \times 100 = t_{on} \times f_{osc} \times 100$$

$$t_{open} \leq t_{off}$$

In Equation 1,  $V_{OUT} \times t_{open} / L$  and  $(V_{IN} - V_{OUT}) \times t_{on} / L$  respectively show the change of the current at "ON", and the change of the current at "OFF".

## **OUTPUT CURRENT AND SELECTION OF EXTERNAL COMPONENTS**

When P-channel Tr. of L<sub>x</sub> is ON:

(Wherein, Ripple Current P-P value is described as I<sub>RP</sub>, ON resistance of P-channel Tr. and N-channel Tr. of L<sub>x</sub> are respectively described as R<sub>ONP</sub> and R<sub>ONN</sub>, and the DC resistor of the inductor is described as R<sub>L</sub>.)

$$V_{IN} = V_{OUT} + (R_{ONP} + R_L) \times I_{OUT} + L \times I_{RP} / t_{on} \dots\dots\dots \text{Equation 2}$$

When P-channel Tr. of L<sub>x</sub> is "OFF"(N-channel Tr. is "ON"):

$$L \times I_{RP} / t_{off} = R_{ONN} \times I_{OUT} + V_{OUT} + R_L \times I_{OUT} \dots\dots\dots \text{Equation 3}$$

Put Equation 3 to Equation 2 and solve for ON duty of P-channel transistor,  $t_{on}/(t_{off}+t_{on})=D_{ON}$ ,

$$D_{ON} = (V_{OUT} - R_{ONN} \times I_{OUT} + R_L \times I_{OUT}) / (V_{IN} + R_{ONN} \times I_{OUT} - R_{ONP} \times I_{OUT}) \dots\dots\dots \text{Equation 4}$$

Ripple Current is as follows;

$$I_{RP} = (V_{IN} - V_{OUT} - R_{ONP} \times I_{OUT} - R_L \times I_{OUT}) \times D_{ON} / f_{osc} / L \dots\dots\dots \text{Equation 5}$$

wherein, peak current that flows through L, and L<sub>x</sub> Tr. is as follows;

$$I_{Lmax} = I_{OUT} + I_{RP} / 2 \dots\dots\dots \text{Equation 6}$$

Consider I<sub>Lmax</sub>, condition of input and output and select external components.

☆ The above explanation is directed to the calculation in an ideal case in continuous mode.



## TIMING CHART

### 1) IC start-up

The timing chart as shown in the next describes the operation starting the IC is enabled with CE. When the CE pin voltage becomes higher than the threshold voltage, the IC's operations starts. At first, only the voltage regulator (VR) starts. The threshold level of the CE pin is between CE "H" input voltage and CE "L" input voltage. After starting the operation, the output capacitor ( $C_{OUT}$ ) is charged with the output current of the VR, and the output level becomes the set VR output voltage. At this moment, the output of Lx is "off", ("Hi-Z"), the pin voltage,  $V_{Lx}=V_{OUT}$  through the external inductor L.

Secondly, the Mode pin voltage is higher than the threshold voltage, internal operation of DC/DC starts. The threshold level is between Mode "H" input voltage and Mode "L" input voltage. The soft-start circuit inside the DC/DC converter's operation is as follows:

(Case 1) DC/DC output voltage < VR output voltage

After the soft-start time, while the output voltage level is down from the VR output voltage to DC/DC output voltage, the circuit is waiting for the start of DC/DC operation. When the output voltage reaches so set DC/DC output voltage level, the actual DC/DC operation starts.

(Case 2) DC/DC output voltage > VR output voltage

The soft-start circuit of DC/DC converter makes the voltage reference unit of the IC rise gradually and be constant. After the voltage reference unit reaches the constant level which the output voltage of DC/DC converter can balance becomes the output voltage of VR, the set output voltage of DC/DC converter may be realized.

Therefore, the soft-start time means the time range of starting to the time when the voltage reference unit reaches the constant level, and the soft-start time is different from turning on speed in some cases. The operation starting time depends on the ability of the power supply, the load current, the inductance value, the capacitance value, and the voltage difference between the set VR output and the set DC/DC output.

If CE and Mode are on at once, the same operation as above is happened except the VR start-up and Soft-start operation start at the same time.

If Mode signal is forced earlier than CE signal, this IC is stand-by until CE signal comes. Therefore when the CE signal is set, the IC operation starts as above.

- **$V_{OUT}$  voltage rising speed at start-up with power supply is affected by the next conditions:**

1. The turning on speed of  $V_{IN}$  voltage limited by the power supply to the IC and the input capacitor  $C_{IN}$ .
2. The output capacitor,  $C_{OUT}$  value and load current.

- **DC/DC operation starting time**

1. If the VR output  $\geq$  DC/DC output, the operation starting time of the DC/DC converter is approximately equal to the next formula.

$$T_{DC/DC\_ACT} = T_{SS} + (V_{OUT\_VR} - V_{OUT\_DC/DC} + 15mV) \times C_{OUT} / (\text{load current at mode change} + 1\mu A)$$

$T_{SS}$ : Soft-start time

$V_{OUT\_VR}$ : VR output voltage

$V_{OUT\_DC/DC}$ : DC/DC Output Voltage

\*1  $\mu A$  is the supply current of the IC itself for the output.

2. If the VR output < DC/DC output, the operation starting time is the soft-start time + starting operation time which depends on the power supply, the load current, and the external components.

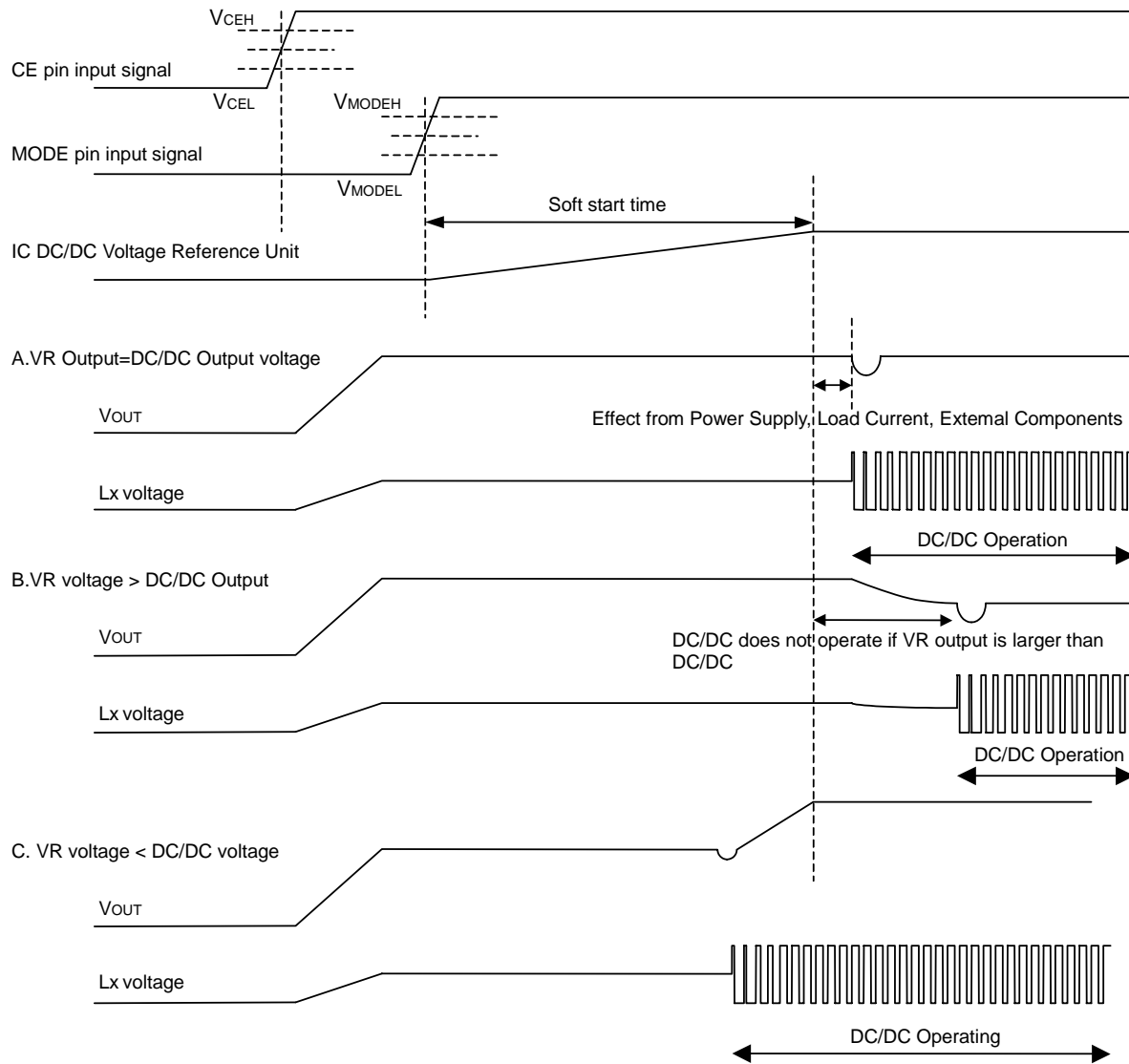

If CE pin input signal is forced earlier than the supply voltage, the voltage difference between the input and the output which is according to the input voltage to  $V_{IN}$ , is maintained and the  $V_{OUT}$  is rising up.

## TEST CIRCUITS

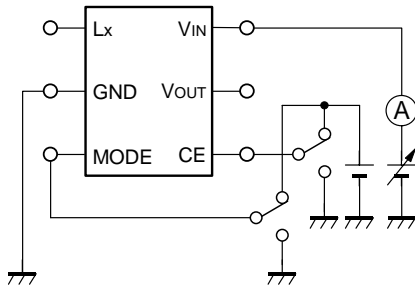

Supply Current 1,2,3

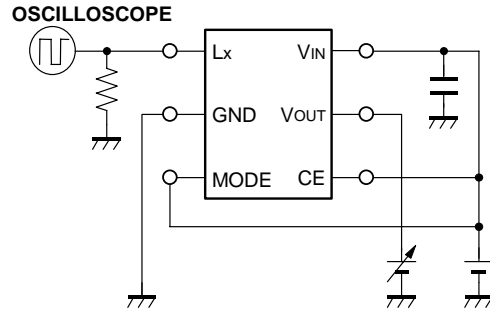

Output Voltage(DC/DC)

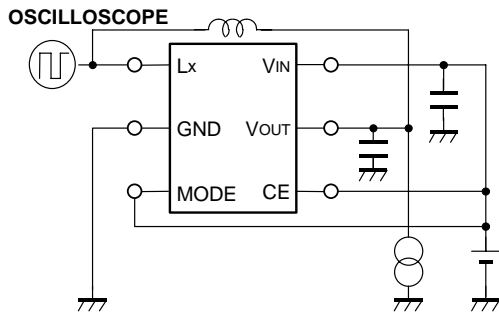

Oscillator Frequency

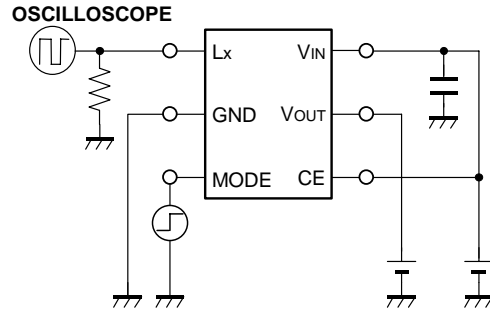

Soft-start Time

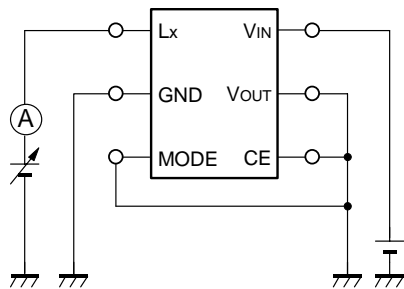

Lx Leakage Current

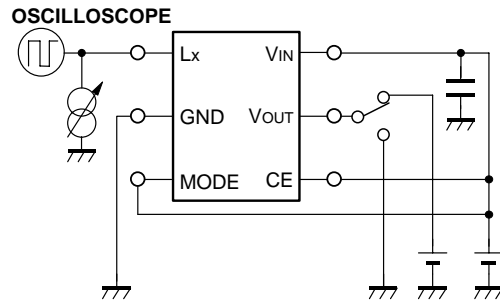

Lx Current Limit, Output Delay for Protection  
Lx Pch transistor ON resistance  
Nch transistor ON resistance

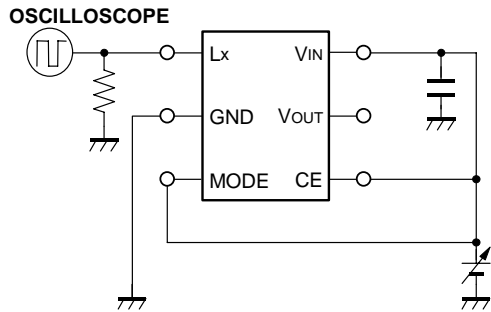

UVLO Detector Threshold UVLO Release Voltage

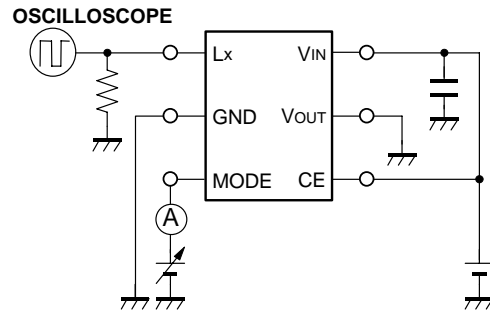

MODE Input Voltage "H", "L" Input Current

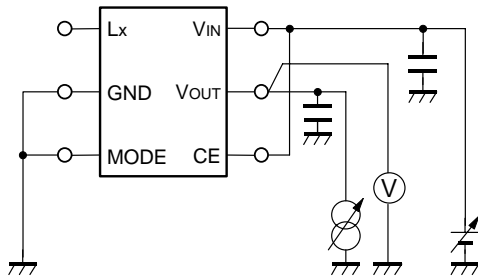

Output Voltage (VR), Load Regulation  
Line Regulation, Dropout Voltage

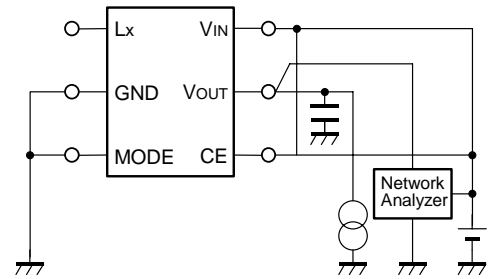

(J) Ripple Rejection

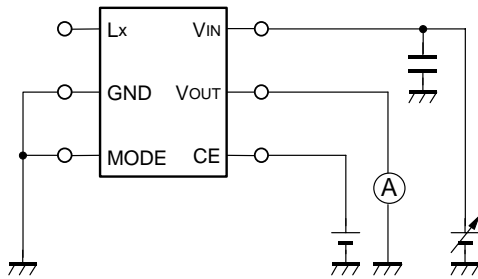

Short Current Limit

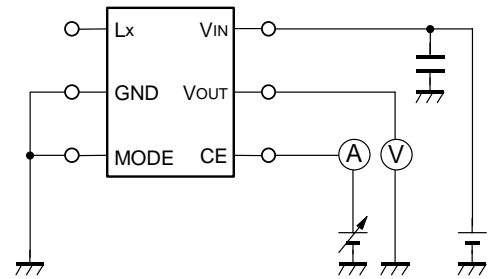

CE="H"/"L" Input Voltage/ Input Current

## TYPICAL CHARACTERISTICS

### 1) DC/DC Converter

1-1) DC/DC Output Voltage vs. Output Current

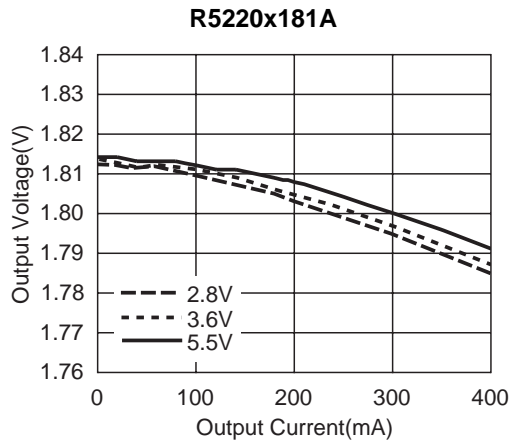

1-2) DC/DC Output Voltage vs. Input Voltage

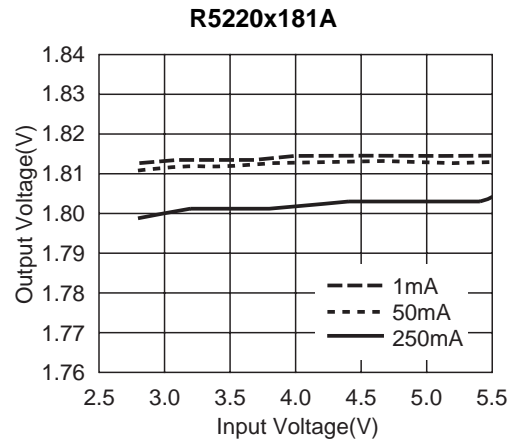

1-3) DC/DC Efficiency vs. Output Current

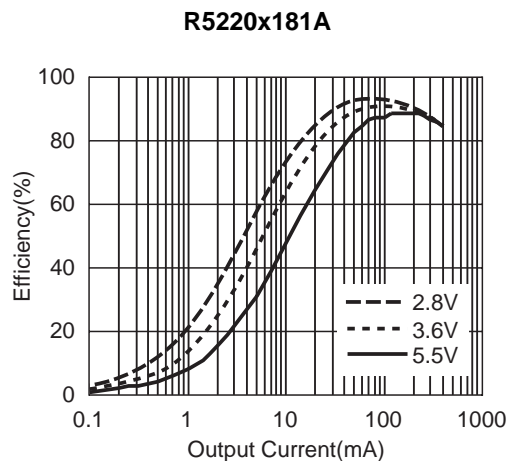

1-4) DC/DC Supply Current vs. Temperature

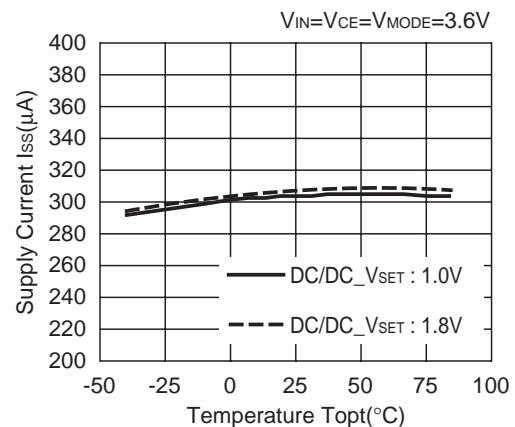

1-5) DC/DC Supply Current vs. Input Voltage

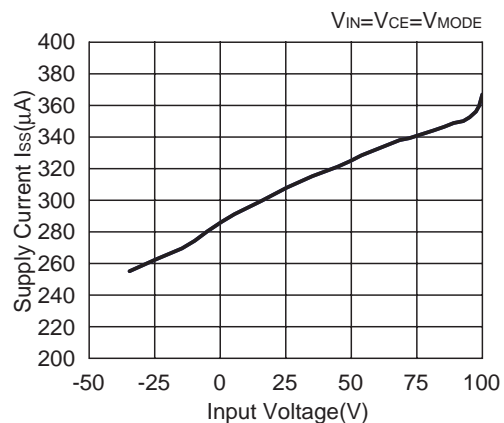

1-6) DC/DC Output Waveform

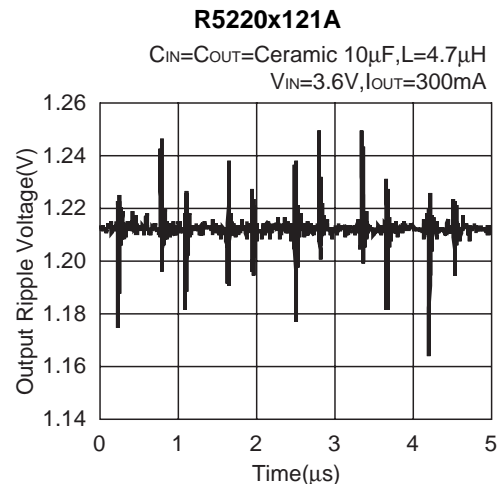

1-7) DC/DC Output Voltage vs. Temperature

R5220x181A

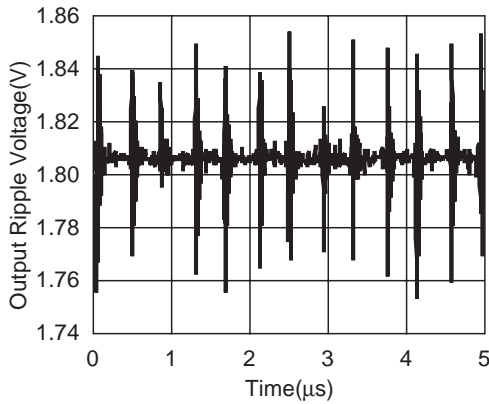

R5220x181A

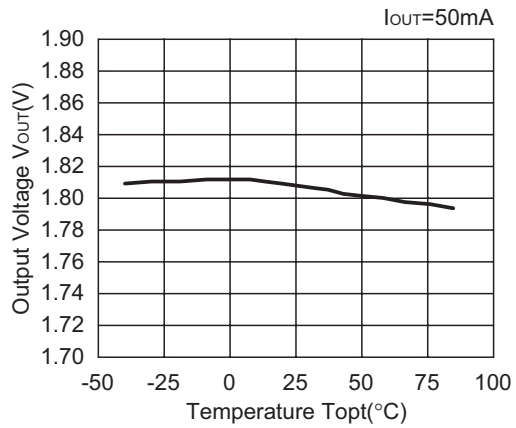

1-8) DC/DC Oscillator Frequency vs. Temperature

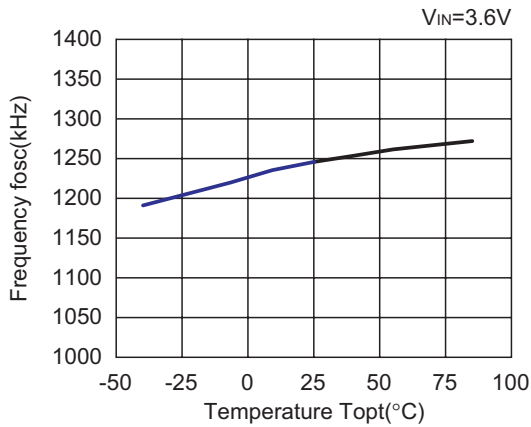

1-9) DC/DC Oscillator Frequency vs. Input Voltage

R5220x181A

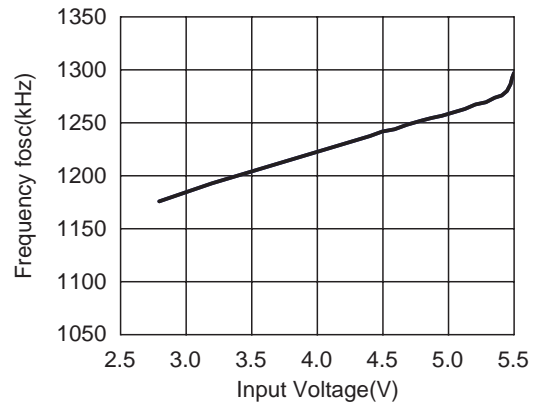

1-10) Soft-start time vs. Temperature

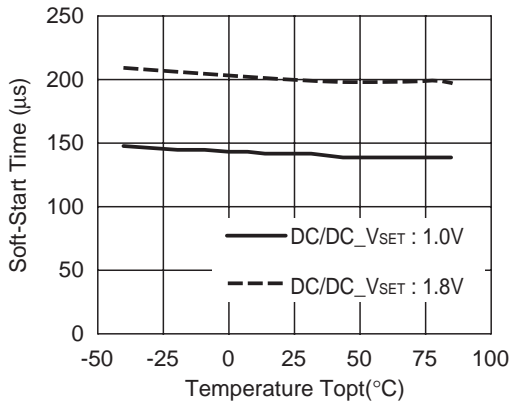

1-11) UVLO Detector Threshold/ Released Voltage vs. Temperature

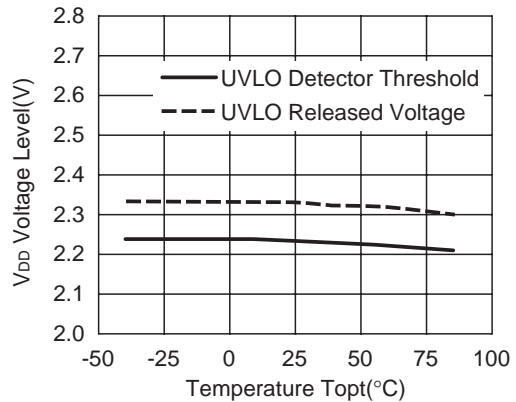

1-12) MODE Input Voltage vs. temperature

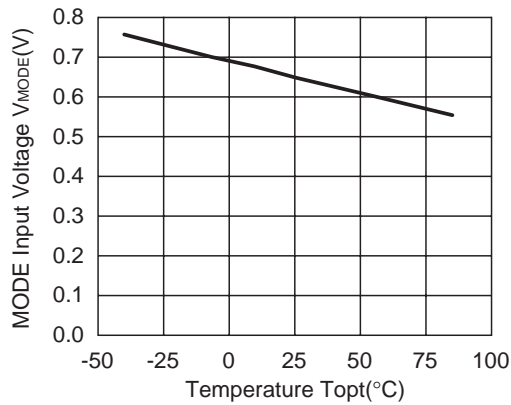

1-13) Pch Transistor On Resistance vs. Temperature

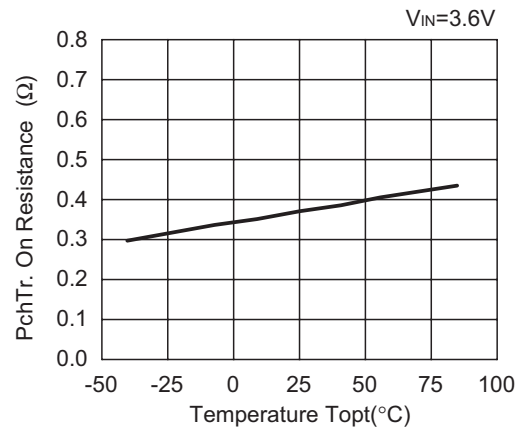

1-14) Nch Transistor On Resistance vs. Temperature

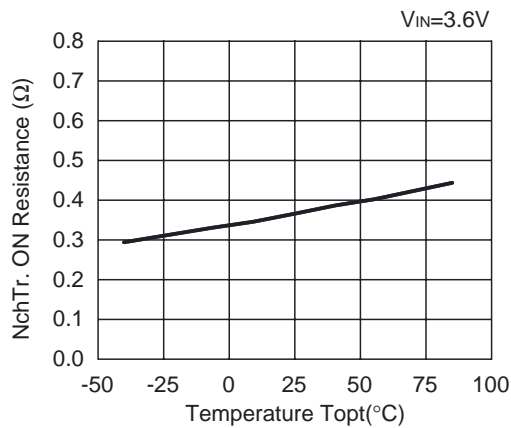

1-15) DC/DC Lx Current Limit vs. Temperature

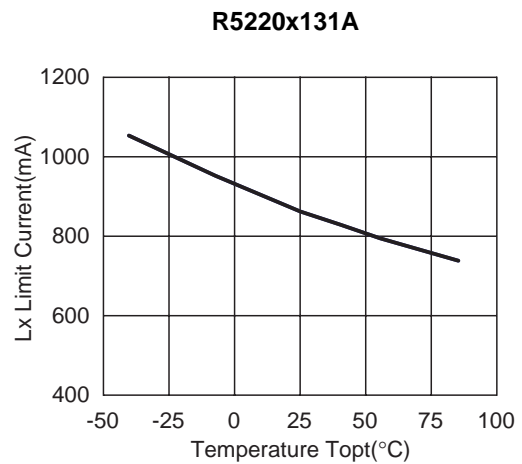

2) VR

2-1) VR Output Voltage vs. Output Current

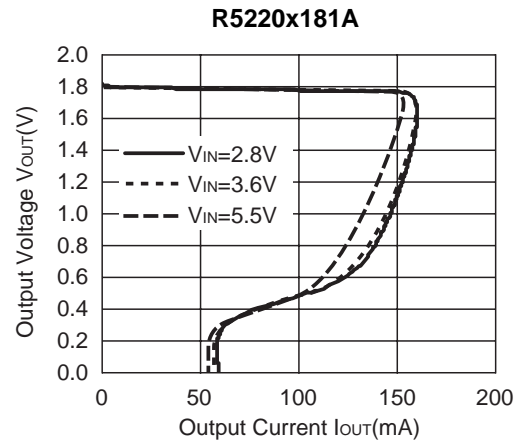
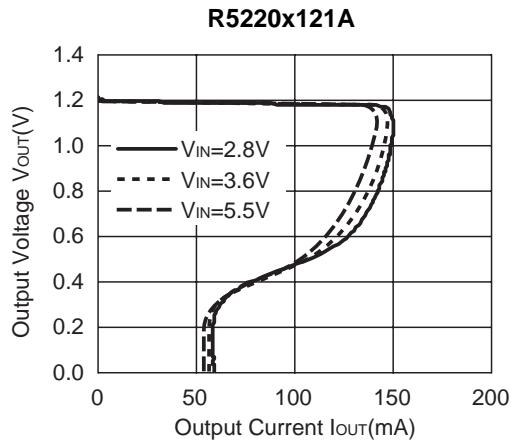

## R5220x

### 2-2) VR Output Voltage vs. Input Voltage

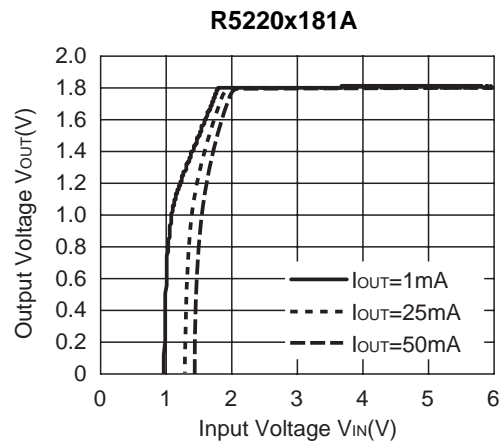
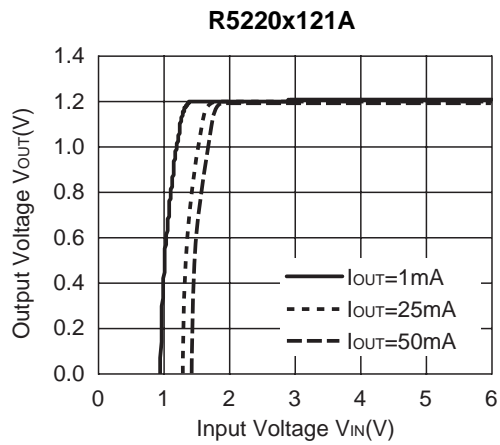

### 2-3) VR Supply Current vs. Input Voltage

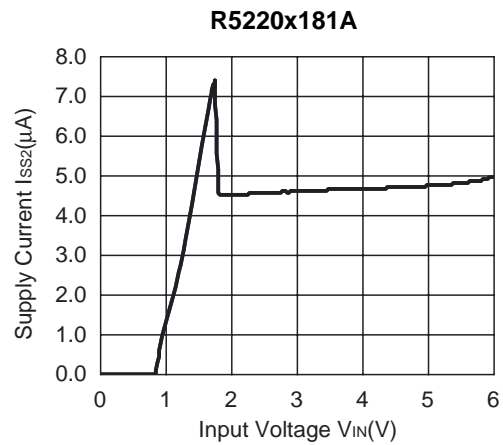
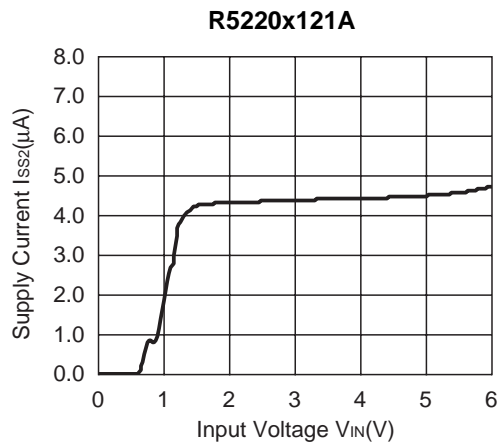

### 2-4) VR Output Voltage vs. Temperature

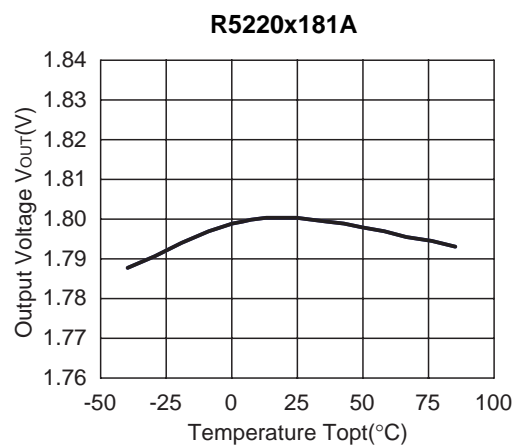
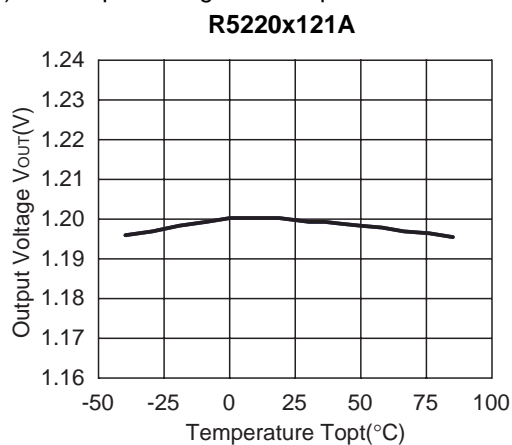



2-5) VR Supply Current vs. Temperature

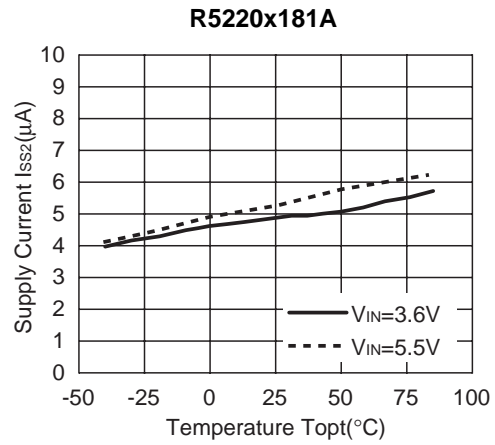
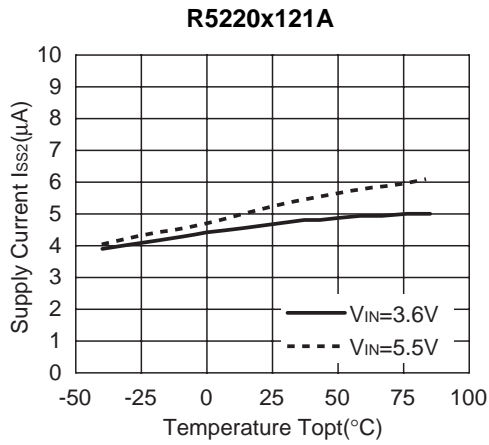

2-6) Dropout Voltage vs. Output Current

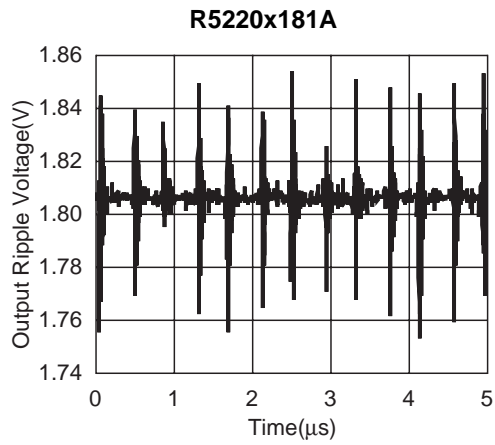
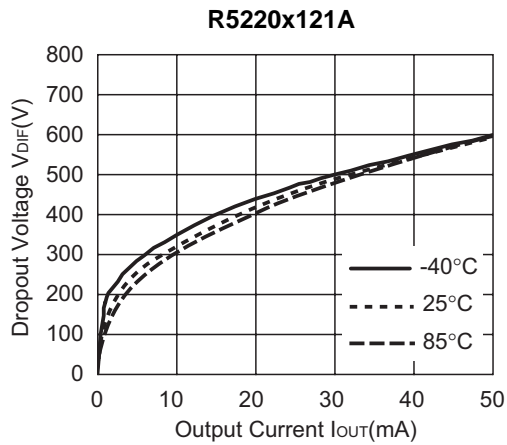

2-7) Ripple Rejection vs. Input Voltage

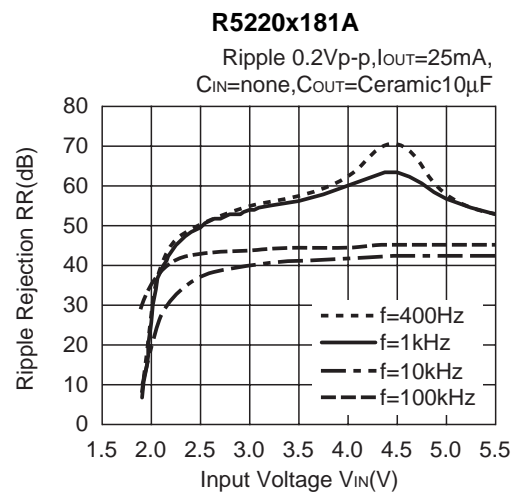
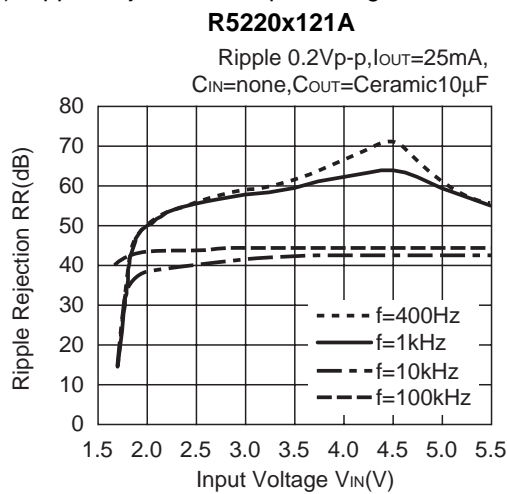

2-8) VR Ripple Rejection vs. Frequency

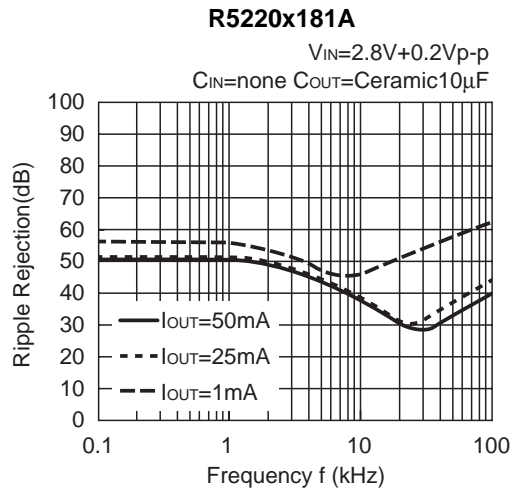
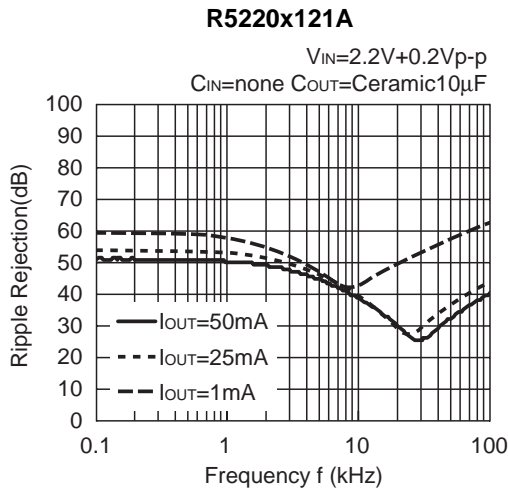

2-9) Input Transient Response

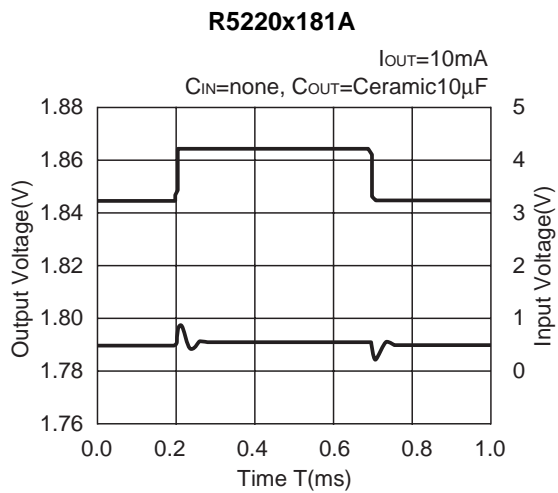
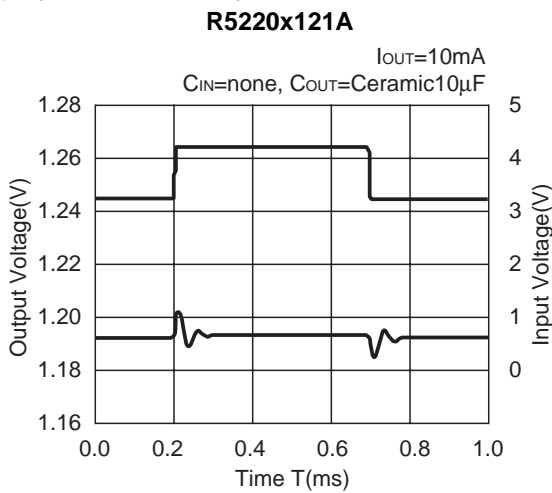

2-10) Load Transient Response

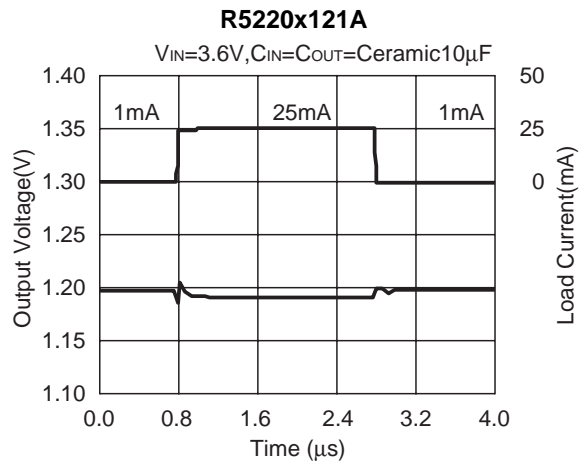
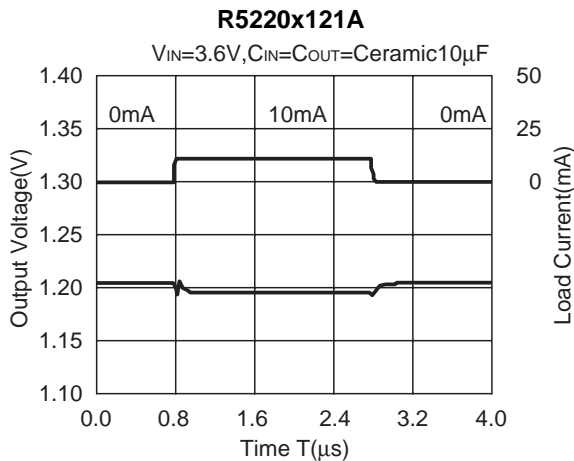

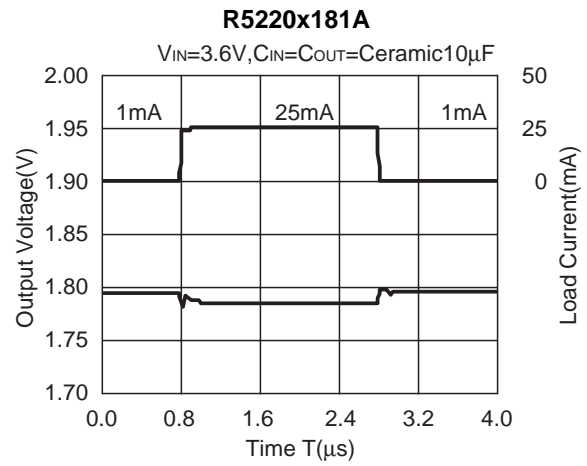
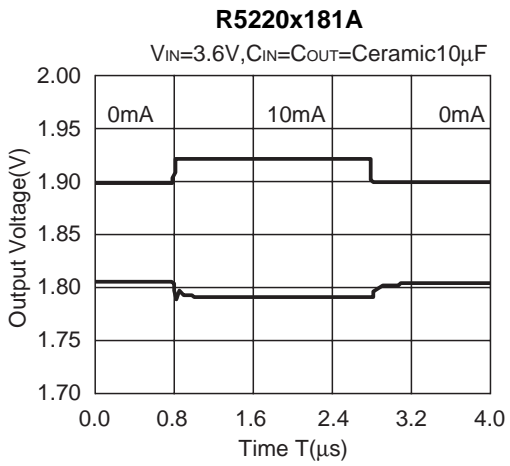

**3) Mode Transient Response between VR and DC/DC**

3-1) VR to DC/DC Mode Transient Response

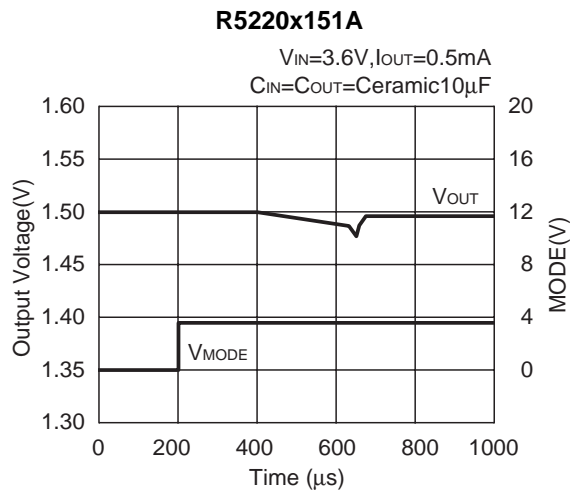

3-2) DC/DC to VR Mode Transient Response

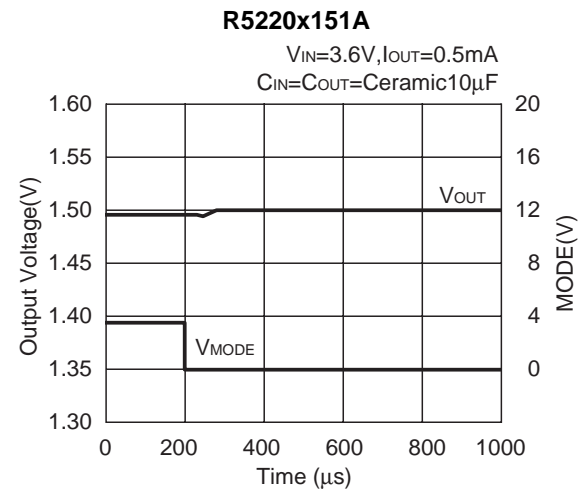

• SON-6

Unit: mm

PACKAGE DIMENSIONS

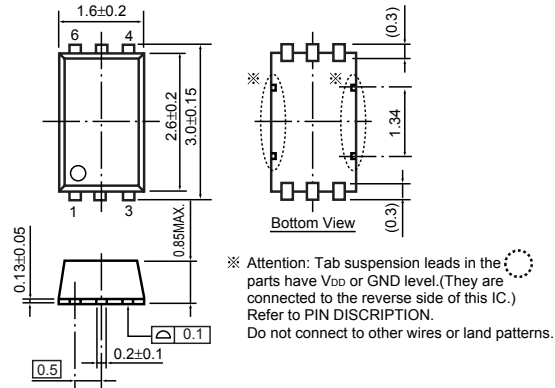

TAPING SPECIFICATION

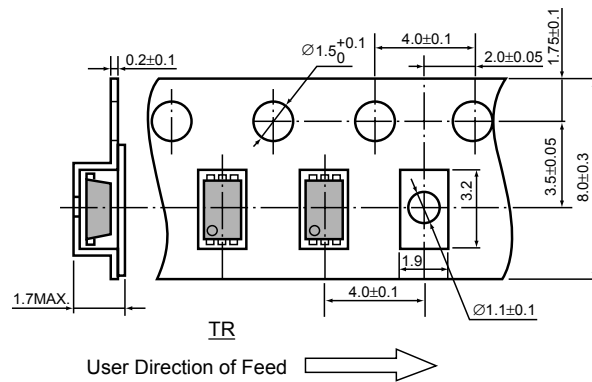

TAPING REEL DIMENSIONS

(1reel=3000pcs)

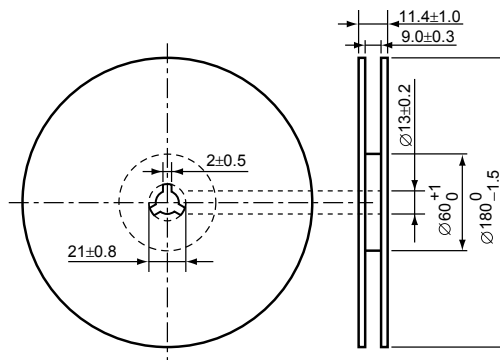

### POWER DISSIPATION (SON-6)

This specification is at mounted on board. Power Dissipation ( $P_D$ ) depends on conditions of mounting on board. This specification is based on the measurement at the condition below:

Measurement Conditions

	Standard Land Pattern
Environment	Mounting on Board (Wind velocity=0m/s)
Board Material	Glass cloth epoxy plactic (Double sided)
Board Dimensions	40mm × 40mm × 1.6mm
Copper Ratio	Top side : Approx. 50% , Back side : Approx. 50%
Through-hole	φ0.5mm × 44pcs

Measurement Result

( $T_{opt}=25^{\circ}C, T_{jmax}=125^{\circ}C$ )

	Standard Land Pattern	Free Air
Power Dissipation	500mW	250mW
Thermal Resistance	$\theta_{ja}=(125-25^{\circ}C)/0.5W=200^{\circ}C/W$	-

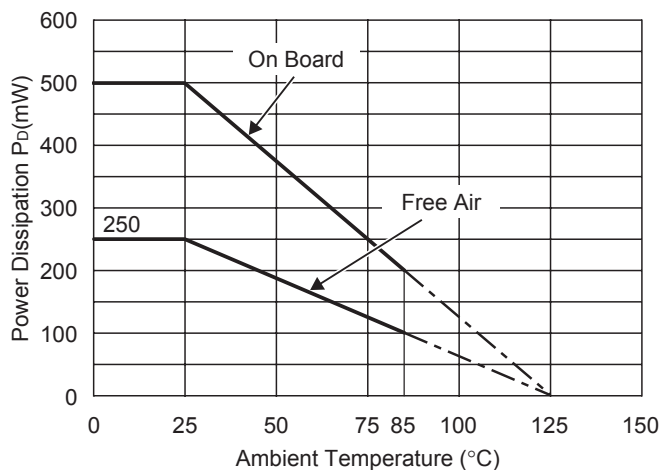

Power Dissipation

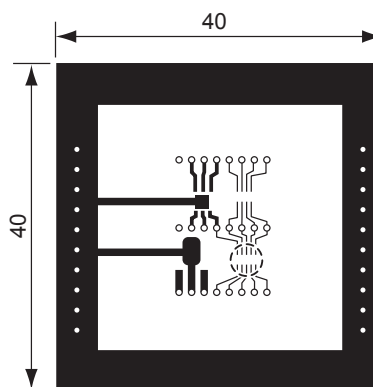

Measurement Board Pattern

○ IC Mount Area (Unit : mm)

### RECOMMENDED LAND PATTERN

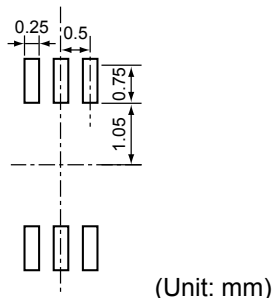



## POWER DISSIPATION (PLP2514-6)

This specification is at mounted on board. Power Dissipation ( $P_D$ ) depends on conditions of mounting on board. This specification is based on the measurement at the condition below:

### Measurement Conditions

	Standard Land Pattern
Environment	Mounting on Board (Wind velocity=0m/s)
Board Material	Glass cloth epoxy plactic (Double sided)
Board Dimensions	40mm × 40mm × 1.6mm
Copper Ratio	Top side : Approx. 50% , Back side : Approx. 50%
Through-hole	φ0.54mm × 30pcs

### Measurement Result

( $T_{opt}=25^{\circ}C, T_{jmax}=125^{\circ}C$ )

	Standard Land Pattern
Power Dissipation	730mW
Thermal Resistance	$\theta_{ja}=(125-25^{\circ}C)/0.73W=137^{\circ}C/W$

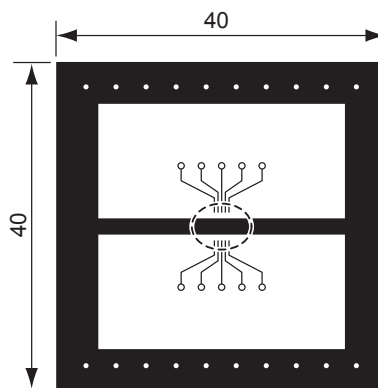
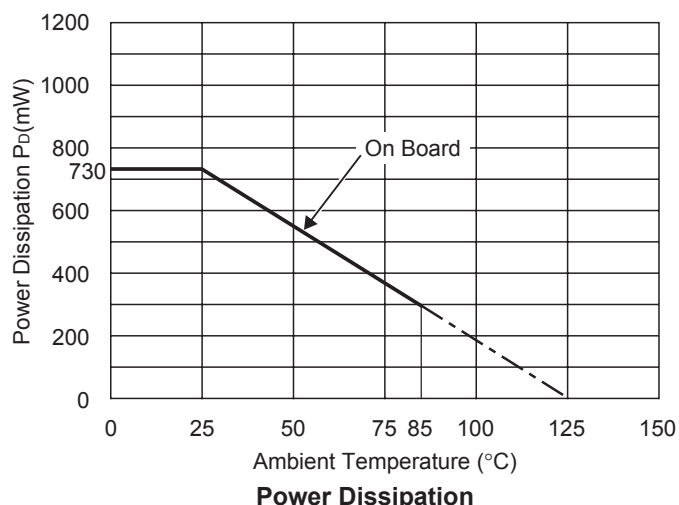

**Measurement Board Pattern**

○ IC Mount Area Unit : mm

## RECOMMENDED LAND PATTERN (PLP2514-6)

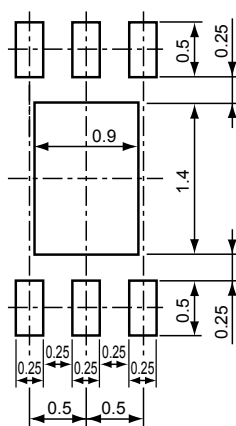

(Unit: mm)

## R5220D SERIES MARK SPECIFICATION

● SON-6

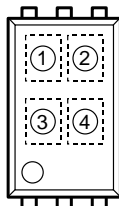

①, ② : Product Code (refer to Part Number vs. Product Code)

③, ④ : Lot Number

● Part Number vs. Product Code

Part Number	Product Code		Part Number	Product Code		Part Number	Product Code		Set V <sub>OUT</sub>	
	①	②		①	②		①	②	DC/DC	VR
R5220D101A	C	A	R5220D101B	D	A	R5220D012A	C	W	1.2V	1.1V
R5220D111A	C	B	R5220D111B	D	B	R5220D022A	C	X	1.5V	1.1V
R5220D121A	C	C	R5220D121B	D	C	R5220D032A	C	Y	1.3V	1.05V
R5220D131A	C	D	R5220D131B	D	D	R5220D042A	C	Z	1.5V	1.0V
R5220D141A	C	E	R5220D141B	D	E					
R5220D151A	C	F	R5220D151B	D	F	R5220D012B	D	W	1.2V	1.1V
R5220D161A	C	G	R5220D161B	D	G	R5220D022B	D	X	1.5V	1.1V
R5220D171A	C	H	R5220D171B	D	H	R5220D032B	D	Y	1.3V	1.05V
R5220D181A	C	J	R5220D181B	D	J	R5220D042B	D	Z	1.5V	1.0V
R5220D191A	C	K	R5220D191B	D	K					
R5220D201A	C	L	R5220D201B	D	L					
R5220D211A	C	M	R5220D211B	D	M					
R5220D221A	C	N	R5220D221B	D	N					
R5220D231A	C	P	R5220D231B	D	P					
R5220D241A	C	Q	R5220D241B	D	Q					
R5220D251A	C	R	R5220D251B	D	R					
R5220D261A	C	S	R5220D261B	D	S					
R5220D271A	C	T	R5220D271B	D	T					
R5220D281A	C	U	R5220D281B	D	U					
R5220D291A	C	V	R5220D291B	D	V					
R5220D301A	C	0	R5220D301B	D	0					
R5220D311A	C	1	R5220D311B	D	1					
R5220D321A	C	2	R5220D321B	D	2					
R5220D331A	C	3	R5220D331B	D	3					
R5220D261A5	C	4	R5220D261B5	D	4					



## R5220K SERIES MARK SPECIFICATION

● PLP2514-6

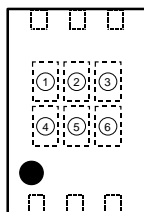

① to ④ : Product Code (refer to Part Number vs. Product Code)

⑤, ⑥ : Lot Number

● Part Number vs. Product Code

Part Number	Product Code				Part Number	Product Code				Set V <sub>OUT</sub>						
	①	②	③	④		①	②	③	④	DC/DC	VR					
R5220K101A	S	1	0	1	R5220K101B	T	1	0	1	R5220K012A	S	0	1	2	1.2V	1.1V
R5220K111A	S	1	1	1	R5220K111B	T	1	1	1	R5220K022A	S	0	2	2	1.5V	1.1V
R5220K121A	S	1	2	1	R5220K121B	T	1	2	1	R5220K032A	S	0	3	2	1.3V	1.05V
R5220K131A	S	1	3	1	R5220K131B	T	1	3	1	R5220K042A	S	0	4	2	1.5V	1.0V
R5220K141A	S	1	4	1	R5220K141B	T	1	4	1							
R5220K151A	S	1	5	1	R5220K151B	T	1	5	1	R5220K012B	T	0	1	2	1.2V	1.1V
R5220K161A	S	1	6	1	R5220K161B	T	1	6	1	R5220K022B	T	0	2	2	1.5V	1.1V
R5220K171A	S	1	7	1	R5220K171B	T	1	7	1	R5220K032B	T	0	3	2	1.3V	1.05V
R5220K181A	S	1	8	1	R5220K181B	T	1	8	1	R5220K042B	T	0	4	2	1.5V	1.0V
R5220K191A	S	1	9	1	R5220K191B	T	1	9	1							
R5220K201A	S	2	0	1	R5220K201B	T	2	0	1							
R5220K211A	S	2	1	1	R5220K211B	T	2	1	1							
R5220K221A	S	2	2	1	R5220K221B	T	2	2	1							
R5220K231A	S	2	3	1	R5220K231B	T	2	3	1							
R5220K241A	S	2	4	1	R5220K241B	T	2	4	1							
R5220K251A	S	2	5	1	R5220K251B	T	2	5	1							
R5220K261A	S	2	6	1	R5220K261B	T	2	6	1							
R5220K271A	S	2	7	1	R5220K271B	T	2	7	1							
R5220K281A	S	2	8	1	R5220K281B	T	2	8	1							
R5220K291A	S	2	9	1	R5220K291B	T	2	9	1							
R5220K301A	S	3	0	1	R5220K301B	T	3	0	1							
R5220K311A	S	3	1	1	R5220K311B	T	3	1	1							
R5220K321A	S	3	2	1	R5220K321B	T	3	2	1							
R5220K331A	S	3	3	1	R5220K331B	T	3	3	1							
R5220K261A5	S	2	6	5	R5220K261B5	T	2	6	5							