

Stepper Motor Drivers

TCA 1561 B
TCA 1560

Advance Information: TCA 1560 G

Bipolar IC

Features

- 2.5 A peak current
- High-speed integrated clamp diodes
- Simple drive
- Thermal overload protection with hysteresis

Type	Ordering Code	Package
☒ TCA 1561 B	Q67000-A8209	P-SIP-9
☒ TCA 1560 B	Q67000-A8208	P-DIP-18-L9
☒ ▼ TCA 1560 G	Q67000-A8272	P-DSO-20-L12 (SMD)

▼ New type

The TCA 1561 B is a bipolar monolithic IC designed to control the motor current in one phase of a bipolar stepper motor. It can also be used to drive direct-current motors as well as all inductive loads operated by constant current.

The IC has TTL-compatible logic inputs and contains a full-bridge driver with integrated, high-speed free-wheeling diodes and chopper-operated dynamic motor current limiting. The nominal current is infinitely variable with a control voltage. Using a minimum of external components and a single supply voltage, two TCA 1561 B ICs form a complete and directly MC-drivable system for two-phase bipolar stepper motors with output currents up to 2.5 A per phase.

The functionally identical TCA 1560 B in P-DIP-18-L9 package is designed for output currents up to 1.25 A.

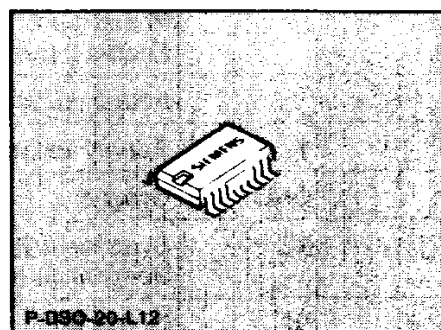
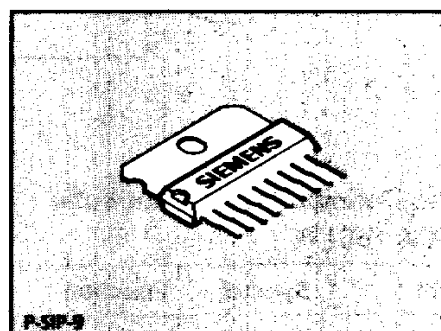
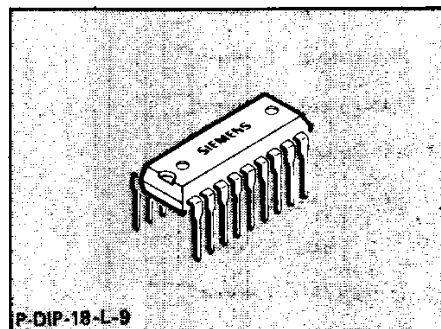

Pin Configurations
(top view)

TCA 1561 B

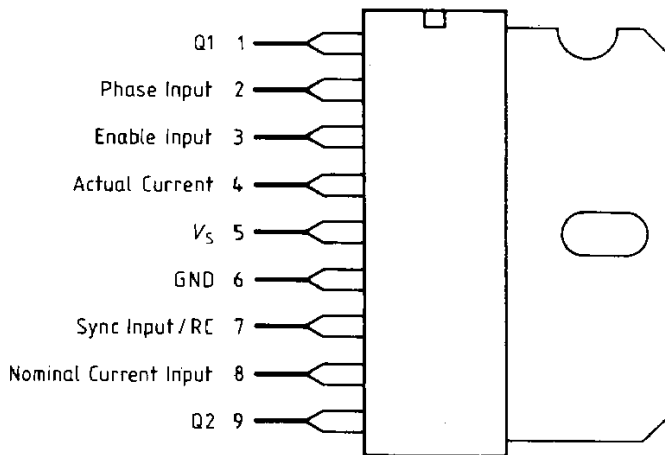

TCA 1560 B

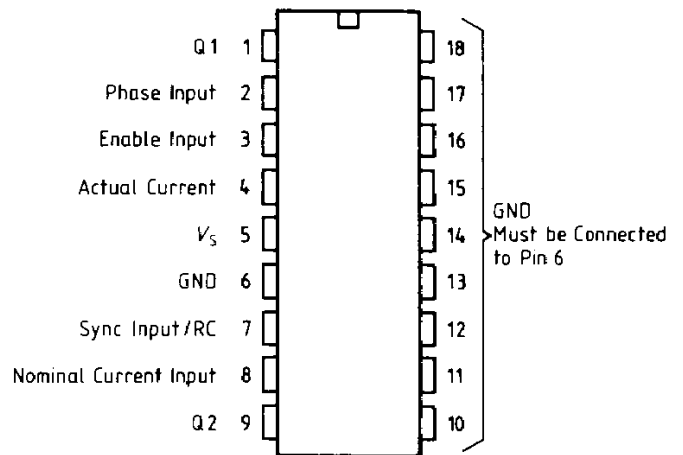

Pin Definitions and Functions
TCA 1561 B

Pin	Symbol	Function
1	Q1	Output Q1
2		Phase input
3		Enable input
4		Actual current
5	V_S	Supply voltage
6	GND	Ground
7	RC	Sync input/RC
8		Nominal current input
9	Q2	Output Q2

The cooling fin is connected internally to pin 6 (ground).

TCA 1560 B

Pin	Symbol	Function
1	Q1	Output Q1
2		Phase input
3		Enable input
4		Actual current
5	V_S	Supply voltage
6	GND	Ground
7	RC	Sync input/RC
8		Nominal current input
9	Q2	Output Q2
10-18	GND	Ground (must be connected to pin 6)

Pin Configuration P-DSO-20-L-12

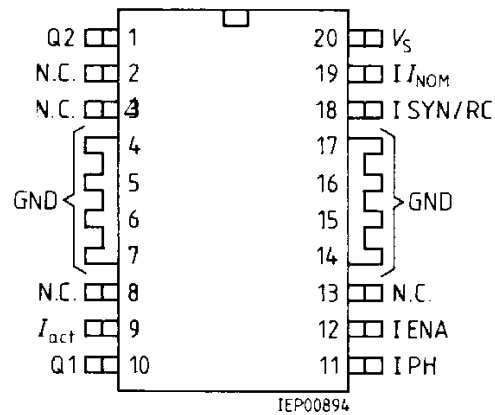

Pin Definitions and Functions

Pin	Symbol	Function
1	Q2	Output
2, 3	N.C.	Not connected
4-7	GND	Ground
8	N.C.	Not connected
9	I_{act}	Actual Current
10	Q1	Output
11	I PH	Phase Input
12	I ENA	Enable Input
13	N.C.	Not connected
14-17	GND	Ground
18	I SYN/RC	Synchron. Input/RC
19	$I I_{NOM}$	Nominal Current Input
20	V_S	Supply Voltage

Block Diagram

Notes in brackets refer to TCA 1560 G!

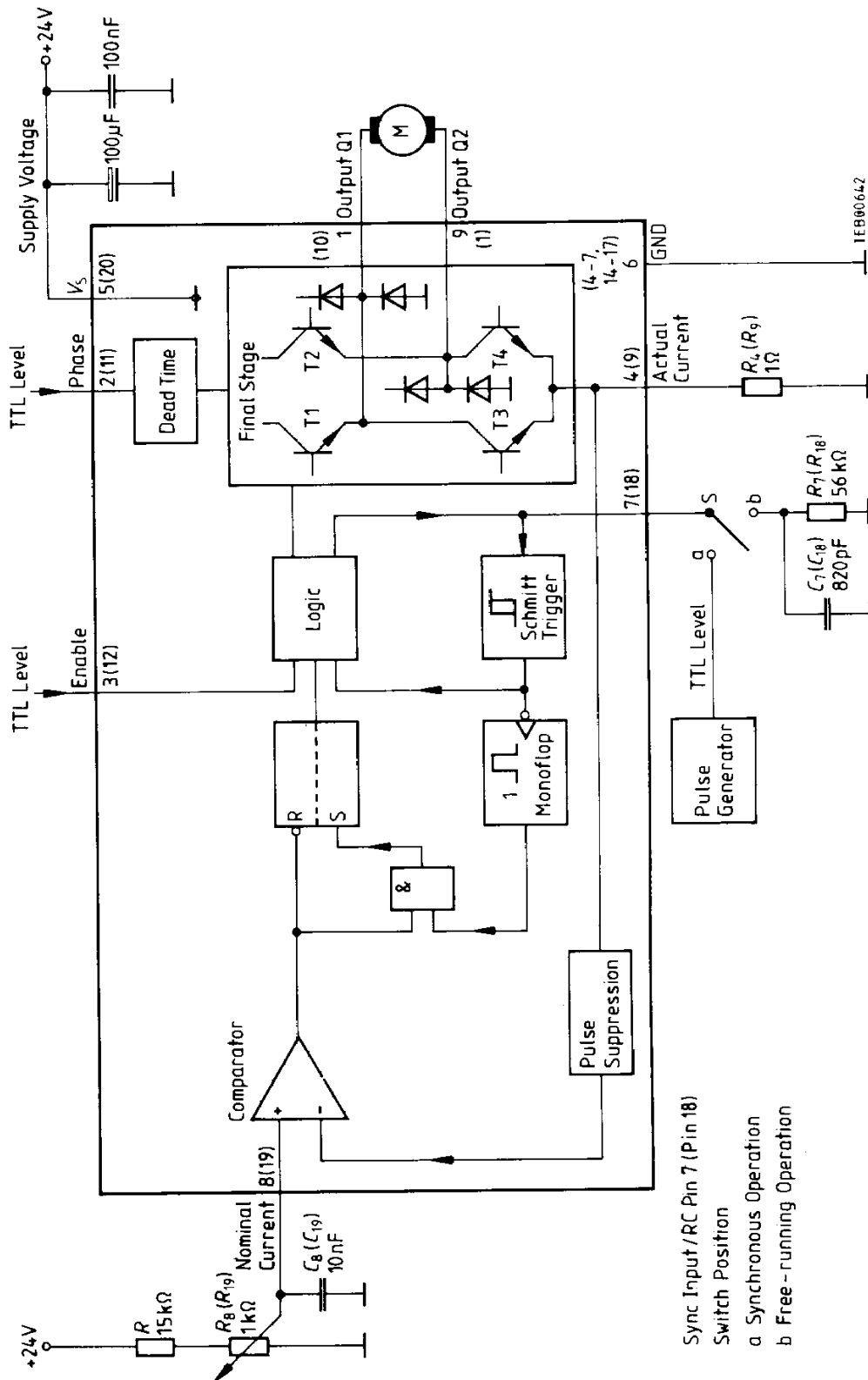

Sync Input / RC Pin 7 (Pin 7)
Switch Position
a Synchronous Operation
b Free-running Operation

Circuit Description

Notes in brackets refer to TCA 1560 G.

Outputs

Outputs Q1, Q2 at pins 1, 9 (pins 1, 10) are fed by push-pull output stages. The two integrated free-wheeling diodes, referred to ground or supply voltage respectively, protect the IC against flyback voltages from an inductive load.

Enable

Outputs Q1 and Q2 are turned off when voltage $V_{13} \leq 0.8 \text{ V}$ is applied to pin 3 (pin 12). The supply current then decreases maximally to 1 mA. The same occurs if pin 3 is not connected. The sink transistors are turned on when $V_{13} \geq 2 \text{ V}$.

Phase

The voltage at pin 2 (pin 11) determines the phase position of the output current. Output Q1 acts as sink for $V_{12} \leq 0.8 \text{ V}$ and as source for $V_{12} \geq 2 \text{ V}$.

Similarly output Q2 acts as

sink when $V_{12} \geq 2 \text{ V}$ and
 source when $V_{12} \leq 0.8 \text{ V}$

The sink transistors are current-chopped. An internal circuit avoids undesired cross-over currents at phase change.

Nominal Current Input

The peak current in the motor winding is determined by the voltage at pin 8 (pin 19). A comparator compares this with the voltage drop at the actual current sensor at pin 4. If the nominal current is exceeded, the output sink transistors are turned off by a logic circuit.

Sync Input/RC

Outputs are turned on by a signal at pin 7 (pin 18). Two operating modes are possible: synchronizing by a fed-in TTL signal or free-running with the external RC combination.

Free-Running Operation

When the supply voltage is applied, capacitor C_7 at pin 7 (pin 18) charges to a limiting voltage, typically 2.4 V. With increasing current in the motor winding, the voltage rises at the actual current sensor R_4 at pin 4 (pin 9). After exceeding the predetermined value at the nominal current input (pin 8) the comparator, in conjunction with pulse suppression, resets an RS flipflop. The logic turns off sink transistors T3 and T4. C_7 ceases charging and the parallel resistance R_7 discharges C_7 . The sink transistors remain turned off until the lower threshold voltage of the Schmitt trigger is reached. This off period is thus controlled by the time constant $t_s = R_7 \times C_7$. After the lower trigger threshold has been passed, the monoflop is triggered by the falling edge of the Schmitt trigger output and, provided the voltage at the actual current sensor at pin 4 (pin 9) is lower than the nominal value at pin 8 (pin 19), the RS flipflop is reset. The logic circuit then turns on the sink transistors T3 or T4 and recharges capacitor C_7 . If the voltage at pin 4 (pin 9) rises above the comparator value at pin 8 (pin 19), the sink transistors T3 and T4 are turned off again. Turn-on cannot be repeated until capacitor C_7 has discharged to the lower trigger threshold, the discharge time being a function of R_7 and C_7 .

Synchronous Operation

Notes in brackets refer to TCA 1560 G

If a TTL level sync signal is fed to pin 7 (pin 18), the negative edge sets the RS flipflop, via the Schmitt trigger/monoflop combination, provided that the voltage at pin 4 (pin 9) is below the nominal value at pin 8 (pin 19). As in the free-running operation mode, the relevant output transistors become conductive. Similarly they are cut off by resetting the RS flipflop once the voltage at pin 4 (pin 9) is higher than the nominal value at pin 8 (pin 19).

Pulse Suppression

In all cases the pulse suppression circuit eliminates positive pulses, typically of 0.5 μ s duration, at pin 4 (pin 9). These can result from cross-over currents in chopper operation through the integrated free-wheeling diodes. As a result, the voltage at pin 4 (pin 9) rises well above the nominal value, and without pulse suppression this would lead to dynamic current limiting. The duration of these basically unavoidable cross-over currents is of the same order of magnitude as the reverse-recovery time of the free-wheeling diodes.

Temperature Safeguard

If the temperature of the IC rises to approx. 150 °C, the final stages are turned off. At approx. 130 °C they are turned on again.

Logic Table

Enable		L	L	H	H
Phase		L	H	L	H
Output	Q1	/	/	L	H
Output	Q2	/	/	H	L
Transistor	T1	X	X	X	.
Transistor	T2	X	X	.	X
Transistor	T3	X	X	..	X
Transistor	T4	X	X	X	..

at:

$$V_4 > 10 \text{ mV} \quad (V_9 > 10 \text{ mV})^*$$

$$R_4 > 0 \Omega \quad (R_9 > 0 \Omega)^*$$

L = Low voltage level, input open

H = High voltage level

X = Transistor turned off

.

.. = Transistor conducting with current limiting turned on

/ = Output high-impedance

Absolute Maximum Ratings $T_C = -40\text{ °C to }85\text{ °C}$

Parameter	Symbol	Limit Values		Unit
		min.	max.	
Supply voltage, pin 5	V_S	-0.3	45	V
Supply current, pin 5	I_S	0	2.5	A
Peak current in output transistors, pin 1, 9	I_Q	-2.5	2.5	A

Diode Currents

Diode to $+V_S$	I_{FH}		2.5	A
Diode to ground	I_{FL}		2.5	A
Input voltage, pins 2, 3, 7, 8	V_I	-0.3	6	V
Output current, pin 4	I_4	-2.5		A
Voltage, pin 4	V_4	-0.3	5	V
Ground current, pin 6	I_6		2.5	A
Junction temperature	T_j		150	°C
Storage temperature	T_{stg}	-40	125	°C
Thermal resistance system – ambient	$R_{th SA}$		70	K/W
Thermal resistance system – case	$R_{th SC}$		8	K/W

Operating Range

Supply voltage, pin 5	V_S	8	40	V
Case temperature	T_C	-40	85	°C
Input voltage, pins 2, 3, 7	V_I		5	V
Output current	I_Q	-2	2	A

Characteristics

$V_S = 24 \text{ V}; T_C = 25^\circ\text{C}$

Parameter	Symbol	Limit Values			Unit	Test Conditions
		min.	typ.	max.		
Supply current, pin 5	I_S		18	30	mA	$V_{I3} = V_{IH}$
Supply current, pin 5	I_S		0.5	1	mA	$V_{I3} = V_{IL}$

Output, Pins 1, 9

Output voltage: source	V_{QH}		1.7	1.9	V	$ I_Q = 1 \text{ A}$
Output voltage: source	V_{QH}		1.9	2.1	V	$ I_Q = 1.5 \text{ A}$
Output voltage: sink	V_{QL}		1.2	1.4	V	$ I_Q = 1 \text{ A}$
Output voltage: sink	V_{QL}		1.5	1.7	V	$ I_Q = 1.5 \text{ A}$
Reverse current	$ I_{QS} $			300	μA	
Phase dead time	t_T	0.1	0.3	1.0	μs	figure 1
Forward voltage of diodes to $+V_S$	V_{FH}		1.0	1.2	V	$I_{FH} = 1 \text{ A}$
Forward voltage of diodes to ground	V_{FL}		1.1	1.3	V	$I_{FH} = 1.5 \text{ A}$
Forward voltage of diodes to ground	V_{FL}		1.1	1.3	V	$I_{FL} = 1 \text{ A}$
Forward voltage of diodes to ground	V_{FL}		1.3	1.5	V	$I_{FL} = 1.5 \text{ A}$

**Inputs: Enable, Pin 3
and Phase, Pin 2**

H-input voltage	V_{IH}	2			V	
L-input voltage	V_{IL}			0.8	V	
H-input current	I_{IH}		50	100	μA	$V_{IH} = 5 \text{ V}$
L-input current	$-I_{IL}$			100	μA	$V_{IL} = 0 \text{ V}$
Rise and fall time	t_r, t_f			2	μs	

Nominal Current, Pin 8

Control range	V_{I8}	0		2	V	
Input current	$-I_{I8}$			5	μA	$V_{I8} = 0 \text{ V}$
Input offset voltage	$V_{I(8-4)}$		0		mV	figure 3

Actual Current, Pin 4

Control range	V_{I4}	0		2	V	figure 3
Turn-off delay	t_D		2	3	μs	figure 4

Sync Input/RC, Pin 7

Sync frequency	f	1		100	kHz	Duty cycle: 0.5 $f = 40 \text{ kHz}$
Duty cycle	D	0.1		0.9		
Rise and fall time	t_r, t_f			2	μs	
Output current, pin 7	$-I_{Q7}$	1.2	1.6	2.0	mA	figure 2
Trigger threshold, pin 7	V_{L7}		0.6	0.8	V	
Charging limit C_7	V_{G7}	2.2	2.4		V	
Off period	t_{OFF}		64		μs	figure 5
Dynamic input resistance pin 7	R_{I7}		1		k Ω	

Absolute Maximum Ratings

$T_C = -25$ to 85 °C

Notes in brackets refer to TCA 1560 G

Parameter	Symbol	Limit Values		Unit
		min.	max.	
Supply voltage, pin 5 (pin 20)*	V_S	-0.3	45	V
Supply current, pin 5 (pin 20)	I_S	0	1.25 (1.0)	A
Peak current in output transistors, pins 1, 9 (pins 1, 10)	I_Q	-1.25 (-1.0)	1.25 (1.0)	A

Diode Currents, Pins 1, 9 (pins 1, 10)

Diode against + V_S	I_{FH}		1.25 (1.0)	A
Diode against ground	I_{FL}		1.25 (1.0)	A
Input voltage, pins 2, 3, 7, 8 (pins 11, 12, 18, 19)	V_I	-0.3	6	V
Output current, pin 4 (pin 9)	I_4 (I_9)	-1.25 (-1.0)		A
Voltage, pin 4 (pin 9)	V_4 (V_9)	-0.3	5	V
Ground current, pin 6 (pin 4 to 7)	I_6 (I_{4-7})		1.25 (1.0)	A
Ground current (pin 14 to 17)	(I_{14-17})		(1.0)	A
Junction temperature	T_j		150	°C
Storage temperature	T_{stg}	-40	125	°C
Thermal resistance junction – ambient	$R_{th JA}$		70	K/W
junction – case (measured at pin 14) (pin 4 to 7)	$R_{th JC}$		15	K/W

Operating Range

Supply voltage, pin 5	V_S	8	40	V
Package temperature measured at pin 14 (pin 4 to 7)	T_C	-25 (-40)	85 (120)	°C
Input voltage, pins 2, 3, 7 (pins 11, 12, 18)	V_I		5	V
Output current, pins 1, 9 (pins 1, 10)	I_Q	-1 (-0.5)	1 (0.5)	A

Characteristics

$V_S = 24\text{ V}$; $T_C = 25\text{ }^\circ\text{C}$

Notes in brackets refer to TCA 1560 G.

Parameter	Symbol	Limit Values			Unit	Test Conditions
		min.	typ.	max.		
Supply current, pin 5 (pin 20)	I_S		18	30	mA	$V_{I3} = V_{IH}$
Supply current, pin 5 (pin 20)	I_S		0.5	1	mA	$V_{I3} = V_{IL}$

Output, Pins 1, 9 (pins 1, 10)

Output voltage: source	V_{QH}		1.6	1.8	V	$ I_Q = 0.5\text{ A}$
Output voltage: source	V_{QH}		1.65	1.90	V	$ I_Q = 0.75\text{ A}$
Output voltage: sink	V_{QL}		1.0	1.2	V	$ I_Q = 0.5\text{ A}$
Output voltage: sink	V_{QL}		1.1	1.4	V	$ I_Q = 0.75\text{ A}$
Reverse current	$ I_{QS} $			300	μA	
Phase dead time	t_T	0.1	0.3	1.0	μs	figure 1
Forward voltage of diodes to $+V_S$	V_{FH}		0.9	1.1	V	$I_{FH} = 0.5\text{ A}$
Forward voltage of diodes to ground	V_{FL}		0.95	1.15	V	$I_{FH} = 0.75\text{ A}$
	V_{FL}		0.95	1.15	V	$I_{FL} = 0.5\text{ A}$
	V_{FL}		1.0	1.2	V	$I_{FL} = 0.75\text{ A}$

Inputs: Enable, Pin 3 (pin 12) and Phase, Pin 2 (pin 11)

H-input voltage	V_{IH}	2			V	
L-input voltage	V_{IL}			0.8	V	
H-input current	I_{IH}		50	100	μA	$V_{IH} = 5\text{ V}$
L-input current	$-I_{IL}$			100	μA	$V_{IL} = 0\text{ V}$
Rise and fall time	t_r, t_f			2	μs	

Nominal Current, Pin 8 (pin 19)

Control range	$V_{I8} (V_{I9})$	0		2	V	
Input current	$-I_{I8} (-I_{I9})$			5	μA	$V_{I8} = 0\text{ V}$
Input offset voltage	$V_{I(8-4)}$		0		mV	figure 3

Actual Current, Pin 4 (pin 9)

Regulating range	$V_{I4} (V_{I9})$	0		2	V	figure 3
Turn-off delay	t_D		2	3	μs	figure 4

Sync Input/RC, Pin 7 (pin 18)

Sync frequency	f	1		100	kHz	Duty cycle: 0.5
Duty cycle	D	0.1		0.9		$f = 40\text{ kHz}$
Rise and fall time	t_r, t_f			2	μs	
Output current, pin 7 (pin 18)	$-I_{Q7} (-I_{Q18})$	1.2	1.6	2.0	mA	
Trigger threshold, pin 7 (pin 18)	$V_{L7} (V_{L18})$		0.6	0.8	V	figure 2
Charging limit $C_7 (C_{18})$	$V_{G7} (V_{G18})$	2.2	2.4		V	
Off period	t_{OFF}		64		μs	figure 5
Dynamic input resistance pin 7 (pin 18)	$R_{I7} (R_{I18})$		1		k Ω	$V_7 = 1.5\text{ V}$ $V_{18} = 1.5\text{ V}$

Internal Wiring of Pins

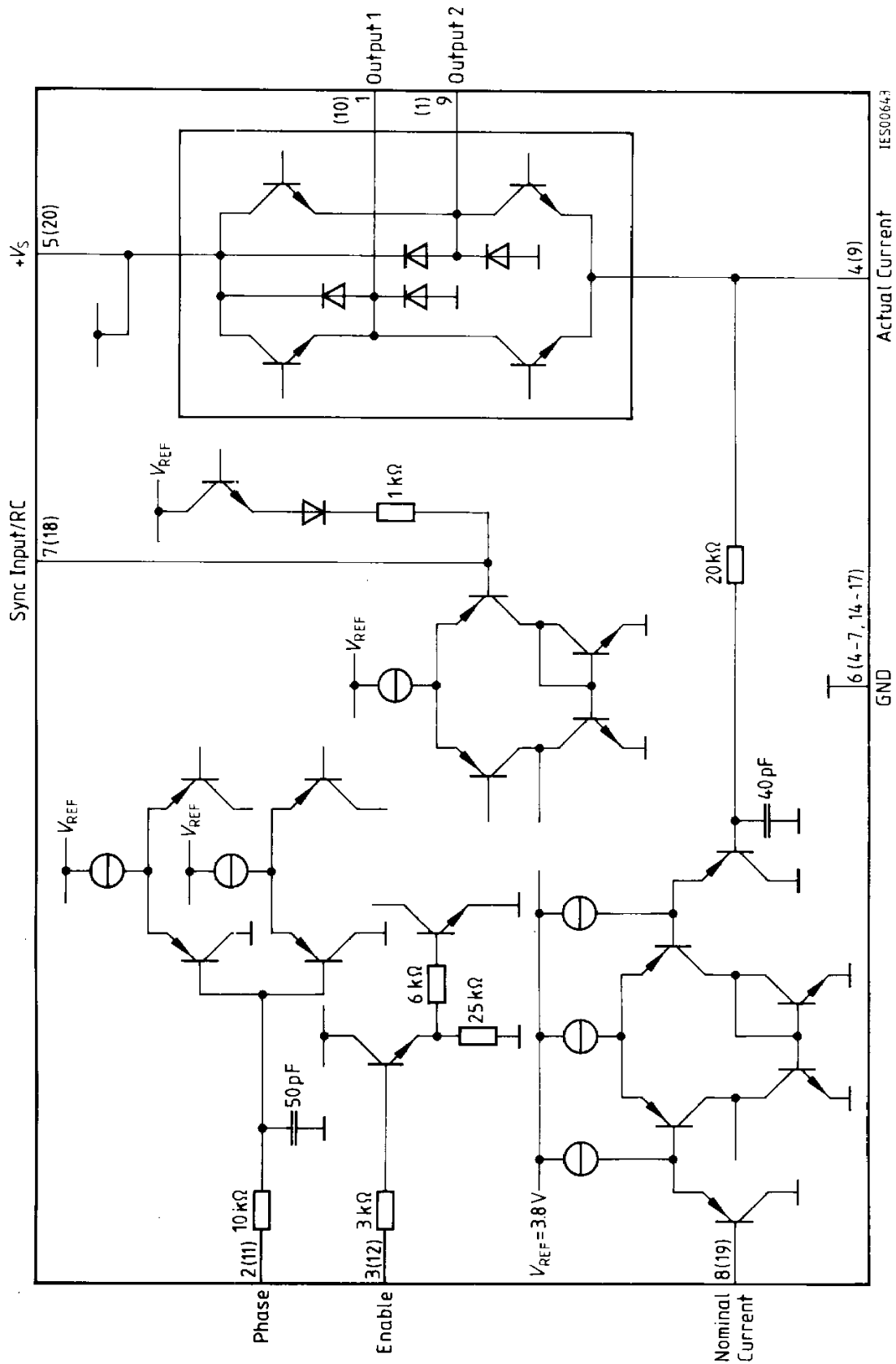

IES00643

Actual Current

Figure 1
Phase Dead Time

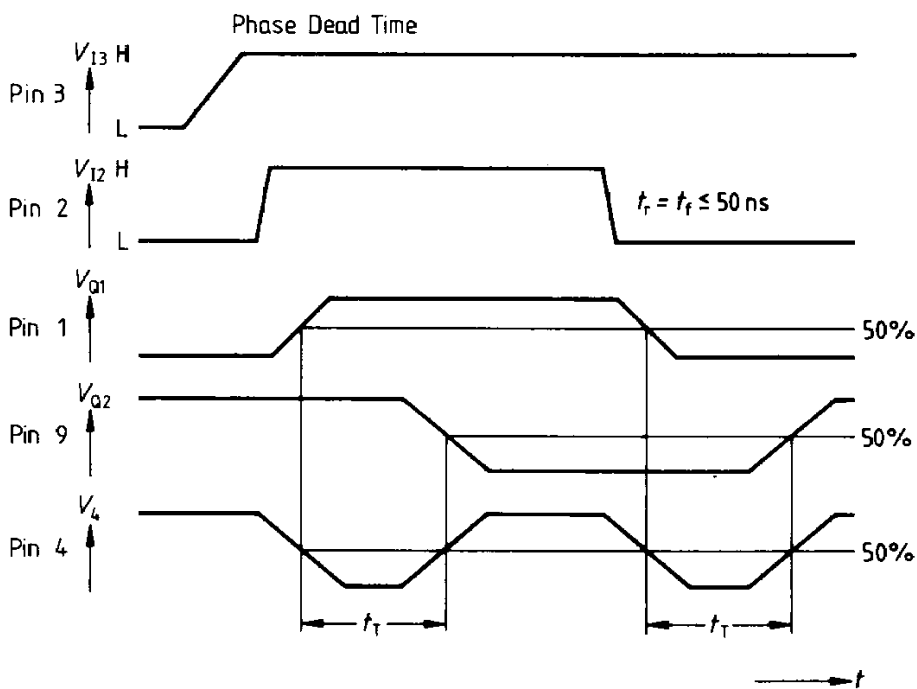

Figure 2
Trigger Threshold

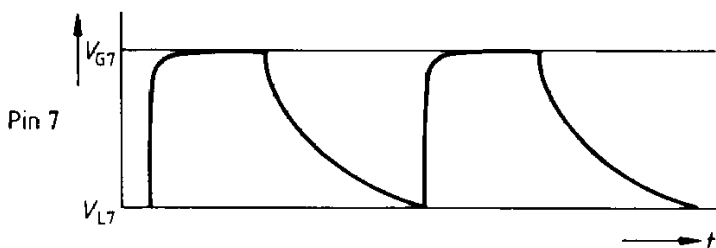

Figure 3
Control Range, Input Offset Voltage

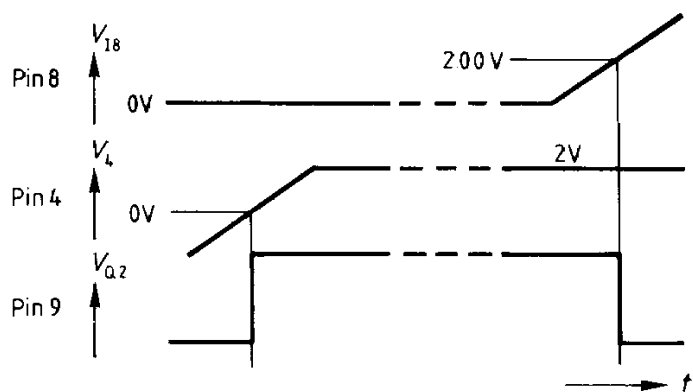

Figure 4
Turn-OFF Delay

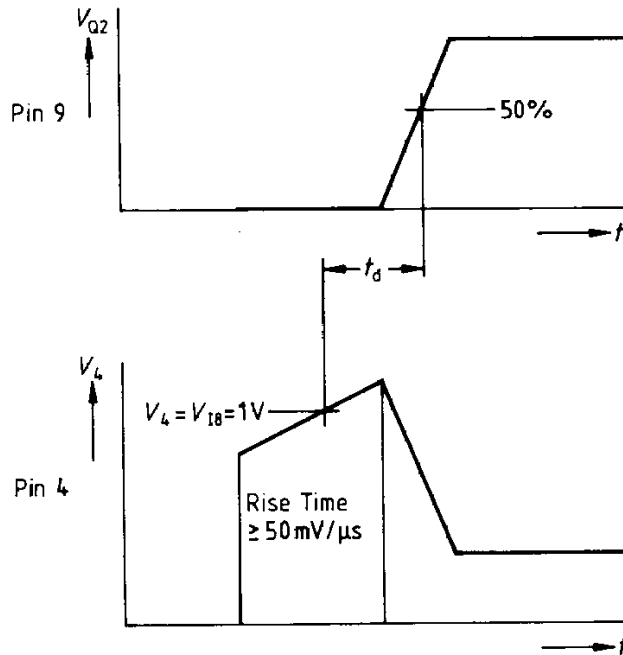
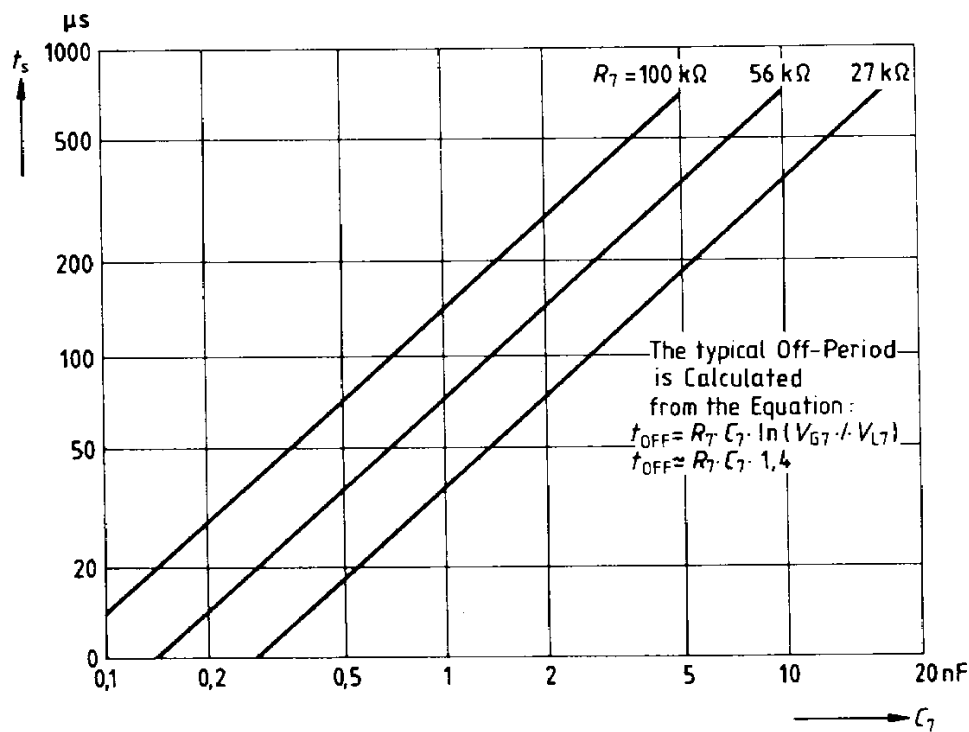
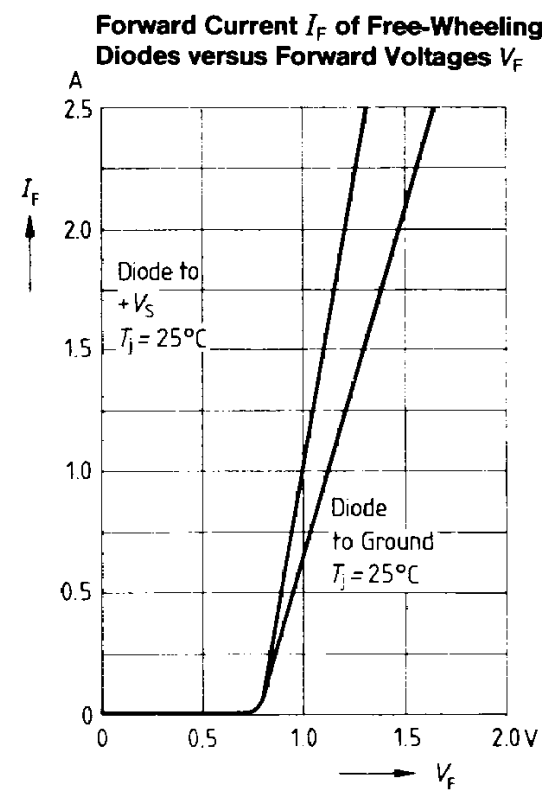
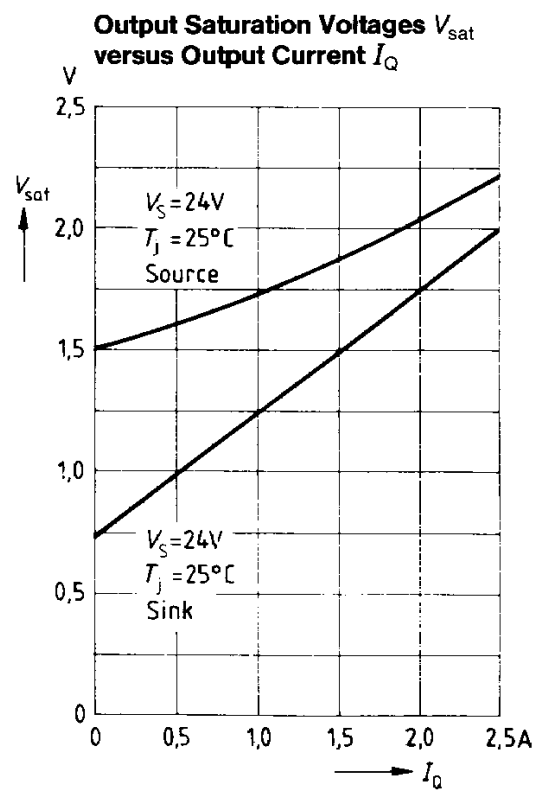
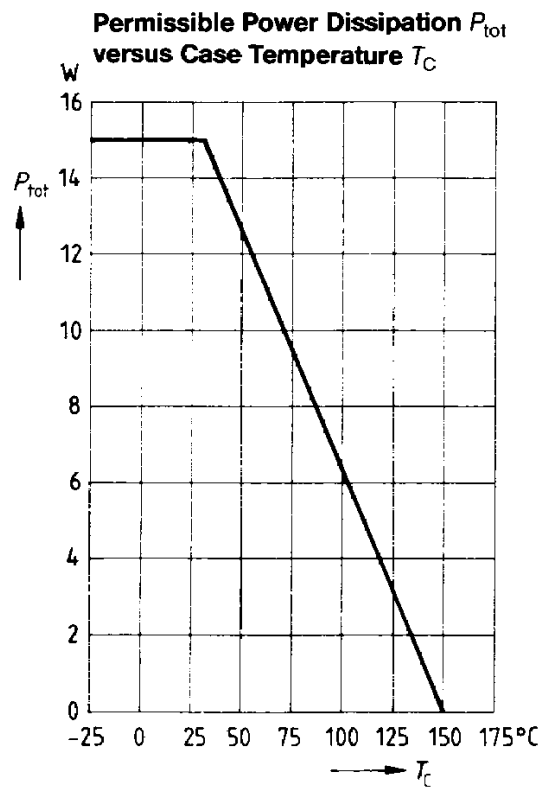
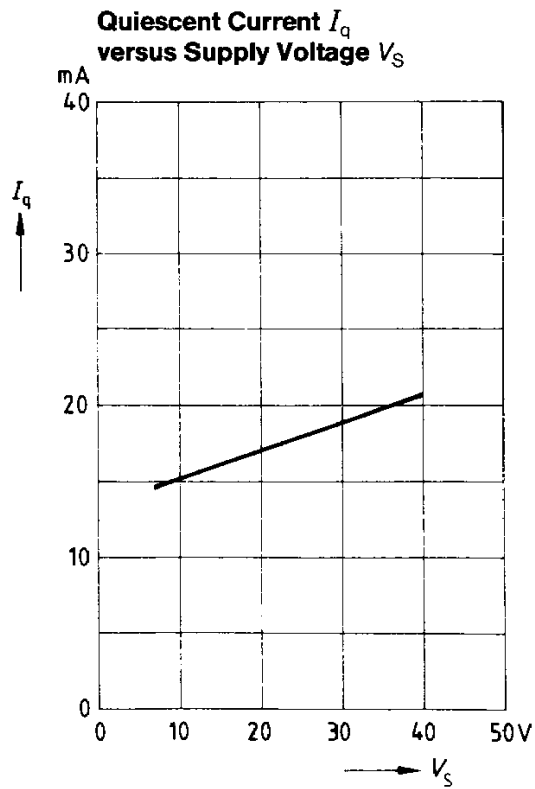
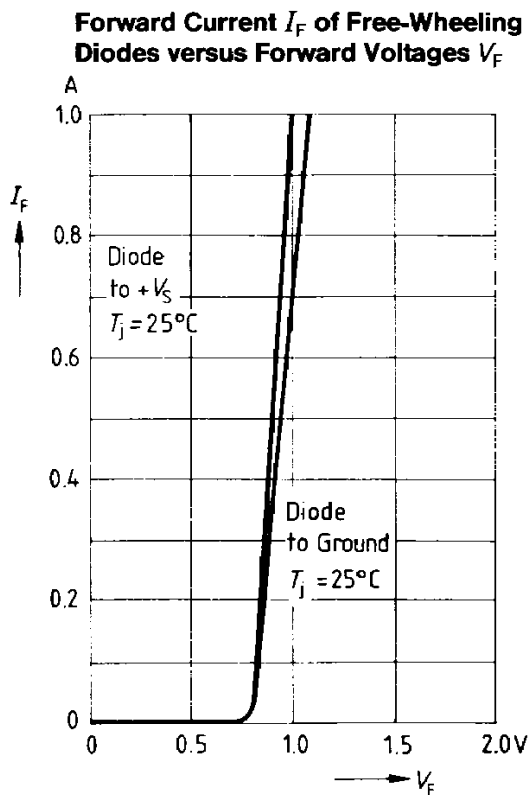
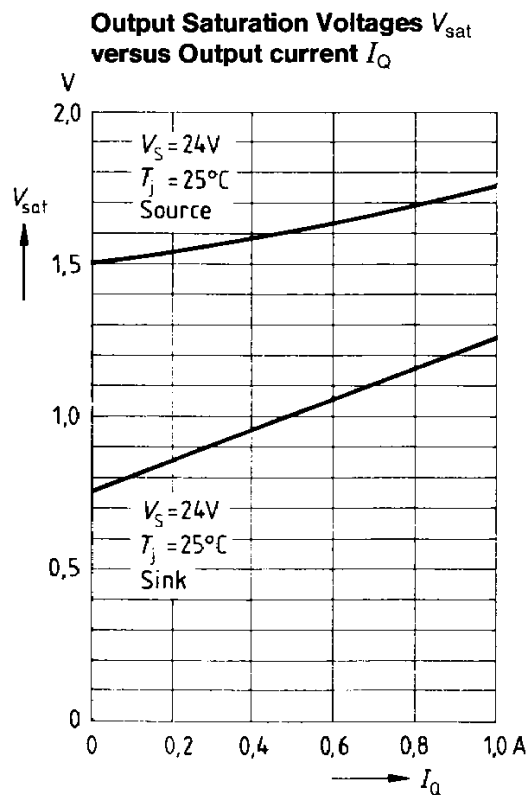
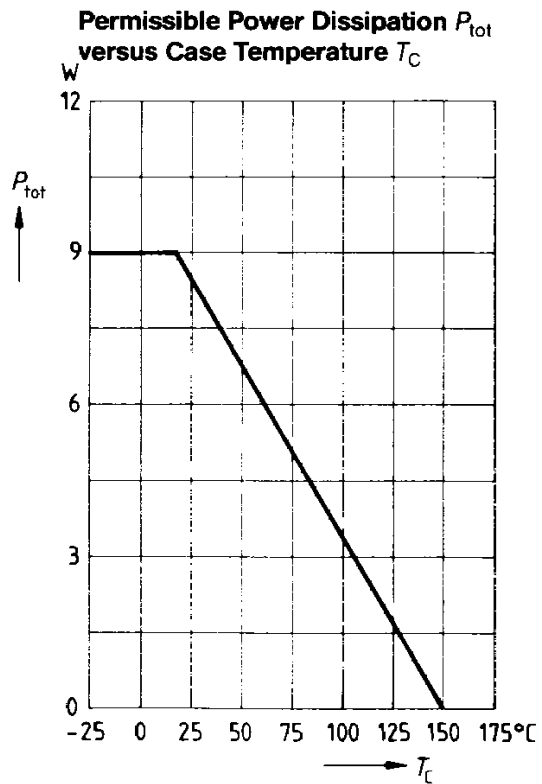
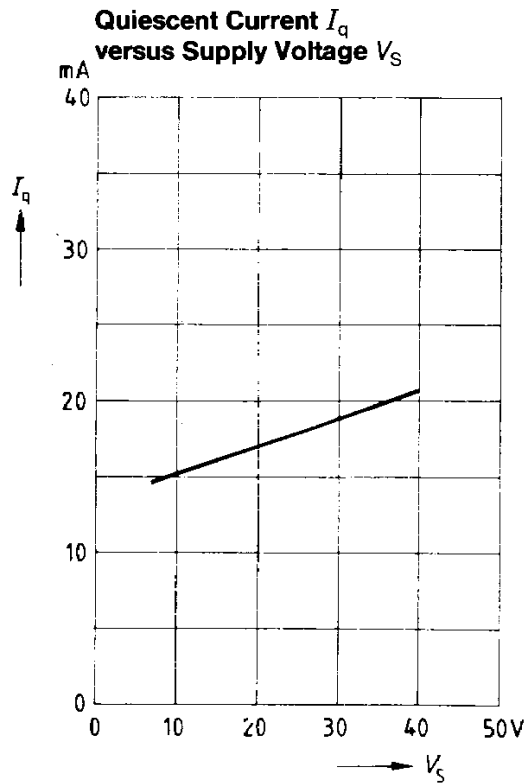

Figure 5
OFF Period versus Capacitance







Application Circuit

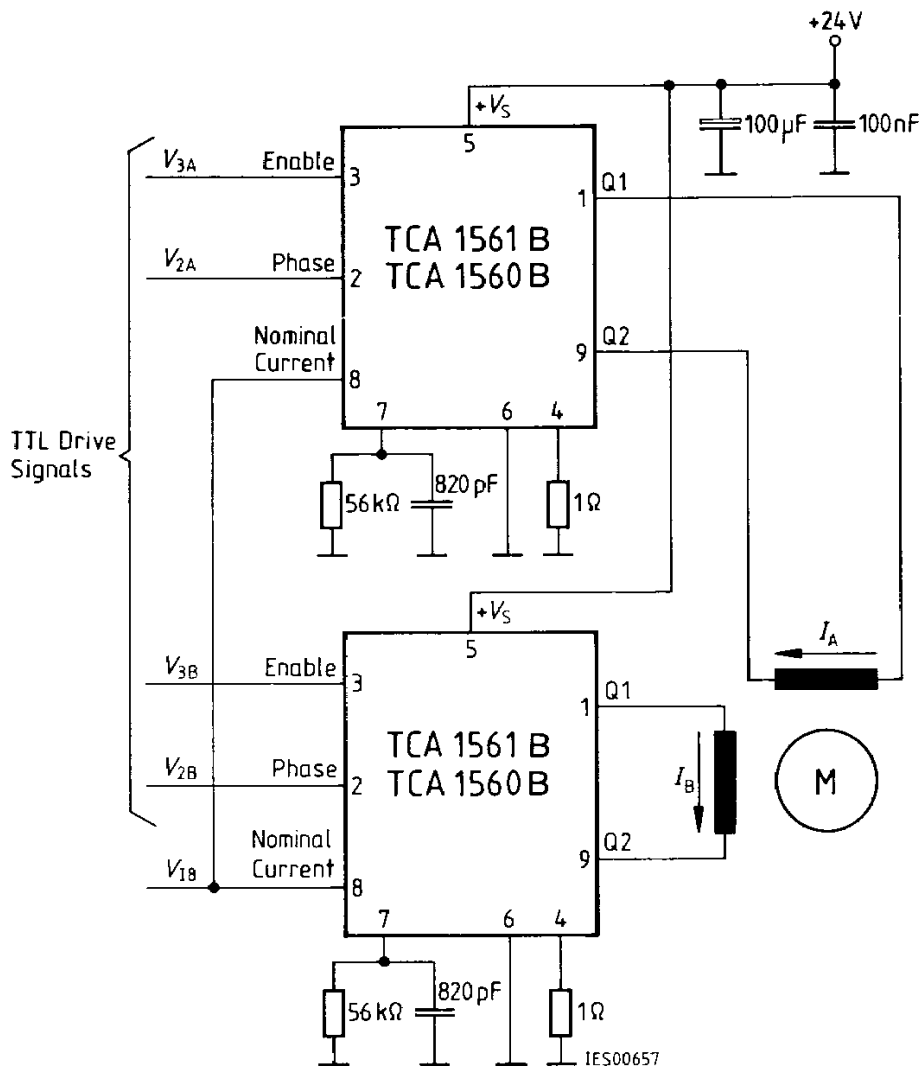

Pulse Diagram for Application Circuit

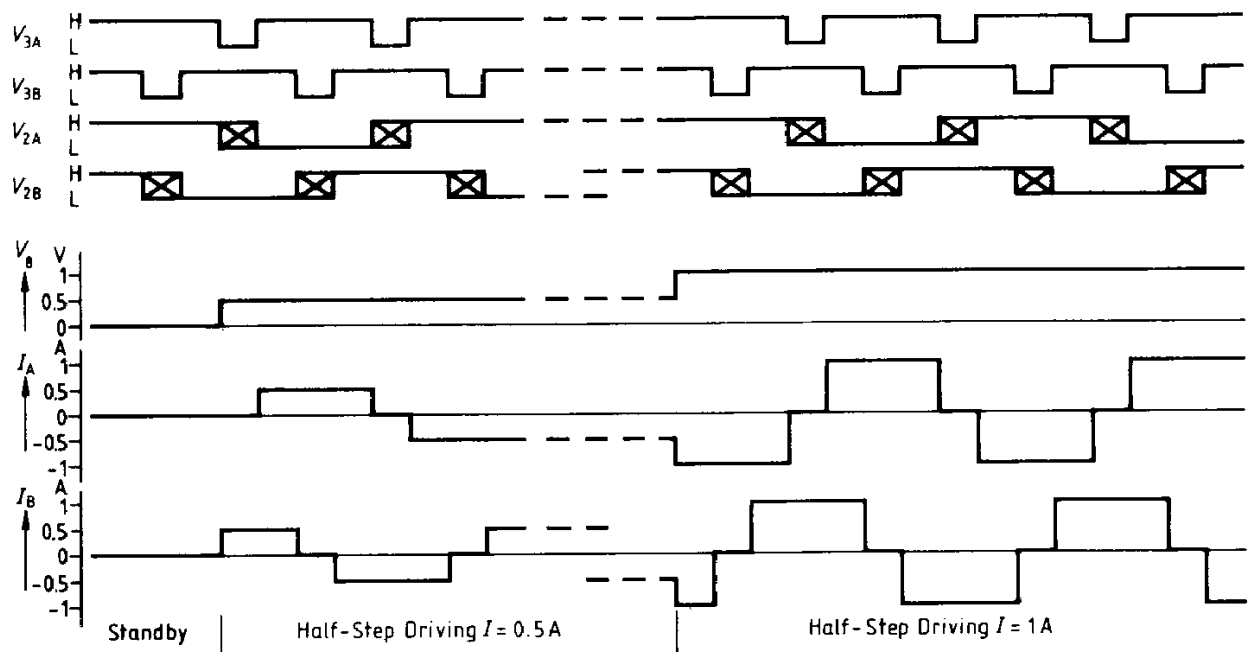

Calculation of Power Dissipation

The total power dissipation P_{tot} comprises

- Saturation losses P_{sat} (transistor saturation voltage and diode forward voltages)
- Quiescent current losses P_q (quiescent current multiplied by supply voltage)
- Switching losses P_s (turn-on/turn-off operation)

9

The following equations give the power dissipation for chopper operation without phase reversal. This can be regarded as "worst case", as, in addition to the switching losses, full-load current flows for the entire time.

$$P_{tot} = P_{sat} + P_q + P_s$$

with $P_{sat} \approx I_R \{ V_{satu} \cdot D + V_{Fo} (1 - D) + V_{sato} \}$

$$P_q = I_q \cdot V_s$$

$$P_s \approx \frac{V_s}{T} \left\{ \frac{i_D \cdot t_{D ON}}{2} + \frac{(i_D + i_r) t_{ON}}{4} + \frac{I_R}{2} (t_{D OFF} + t_{OFF}) \right\}$$

- I_R = Rated current (mean value)
- I_q = Quiescent current
- i_D = Reverse current during turn-on delay time
- i_r = Peak reverse current
- t_p = Conducting time of chop transistor
- t_{ON} = Turn-on time
- t_{OFF} = Turn-off time
- t_{DON} = Turn-on delay time
- t_{DOFF} = Turn-off delay time
- T = Cycle duration
- D = Duty cycle t_p/T
- V_{satu} = Saturation voltage of sink transistor (T3, 4)
- V_{sato} = Saturation voltage of source transistor (T1, 2)
- V_{Fo} = Forward voltage of clamp diode (D1, 2)
- V_S = Supply voltage

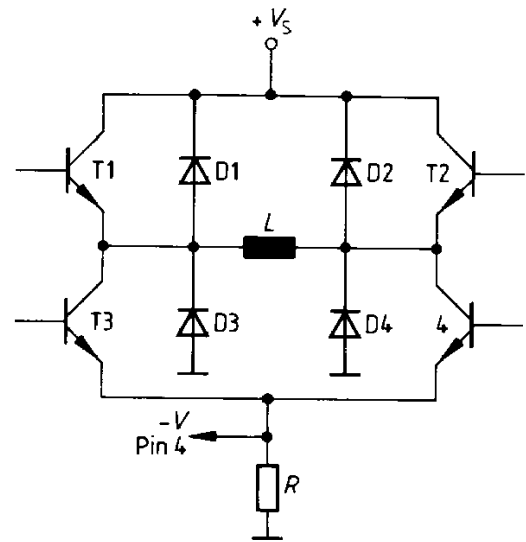

Calculation of Power Dissipation

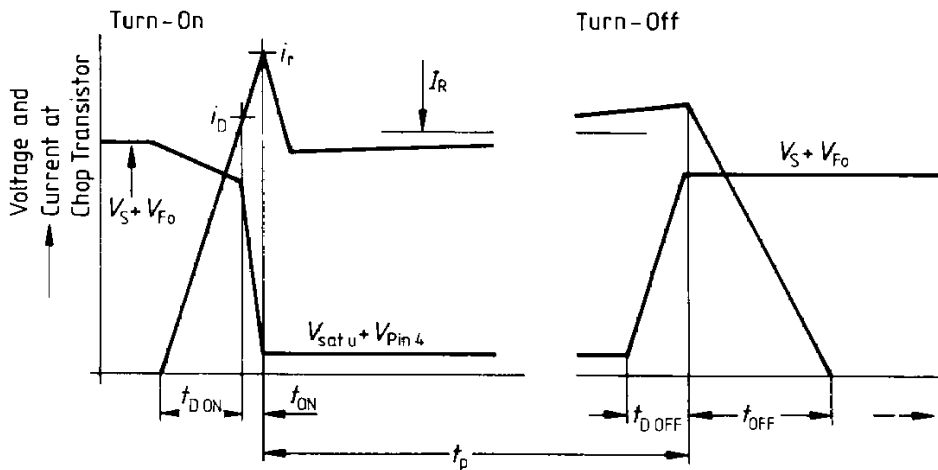

Characteristics for determining the typical power dissipation during chopper operation without phase reversal.

Parameters: $L_{load} = 10 \text{ mH}$, $C_7 = 820 \text{ pF}$; $R_7 = 33 \text{ k}\Omega$; $T_C = 25^\circ\text{C}$

