

3-MODE 300mA LDO REGULATOR

NO.EA-106-0511

OUTLINE

The R1161x Series are CMOS-based voltage regulator ICs with high output voltage accuracy, low supply current, and low ON-resistance. Each of these voltage regulator ICs consists of a voltage reference unit, an error amplifier, resistors for setting output voltage, a current limit circuit, and a chip enable circuit.

These ICs perform with low dropout voltage and a chip enable function. To prevent the destruction by over current, current limit circuit is included. The R1161x Series have 3-mode. One is standby mode with CE or standby control pin. Standby mode realizes ultra small consumption current off mode. Other two modes are realized with ECO pin™. Fast Transient Mode (FT mode) and Low Power Mode (LP mode) are alternative with ECO pin™. Consumption current is reduced at Low Power Mode compared with Fast Transient Mode. Output voltage is maintained between FT mode and LP mode.

The output voltage of these ICs is internally fixed with high accuracy. Since the packages for these ICs are SOT-23-5, SON-6, and HSON-6, high density mounting of the ICs on boards is possible.

FEATURES

- Ultra-Low Supply Current Typ. 3.5 μ A (Low Power Mode, $V_{OUT}<1.6V$),
Typ. 80 μ A (Fast Transient Mode, $V_{OUT}<1.8V$)
Typ. 60 μ A (Fast Transient Mode, $V_{OUT} \geq 1.8V$)
- Standby Mode Typ. 0.1 μ A
- Low Dropout Voltage..... Typ. 0.48V($I_{OUT}=300mA$ Output Voltage=1.0V Type)
Typ. 0.31V($I_{OUT}=300mA$ Output Voltage=1.5V Type)
Typ. 0.23V($I_{OUT}=300mA$ Output Voltage=3.0V Type)
- High Ripple Rejection Typ. 65dB($f=1kHz$, FT Mode)
- Low Temperature-Drift Coefficient of Output Voltage Typ. $\pm 100ppm/^{\circ}C$
- Excellent Line Regulation Typ. 0.01%/V (at Fast Transient Mode)
- High Output Voltage Accuracy $\pm 2.0%$ ($\pm 3.0%$ at LP Mode)
- Small Package SOT-23-5 (Super Mini-mold), SON-6, HSON-6
- Output Voltage Stepwise setting with a step of 0.1V in the range of 0.8V to 3.3V is possible
- Input Voltage Min. 1.40V($V_{OUT} \geq 1.0V$)
Min. 1.45V($V_{OUT}<1.0V$)
- Built-in fold-back protection circuit..... Typ. 50mA (Current at short mode)
- External Capacitors..... $C_{IN} = C_{OUT} =$ Tantalum 1.0 μ F ($V_{OUT}<1.0V$)
 $C_{IN} = C_{OUT} =$ Ceramic 1.0 μ F ($V_{OUT} \geq 1.0V$)

APPLICATIONS

- Precision Voltage References.
- Power source for electrical appliances such as cameras, VCRs and hand-held communication equipment.
- Power source for battery-powered equipment.

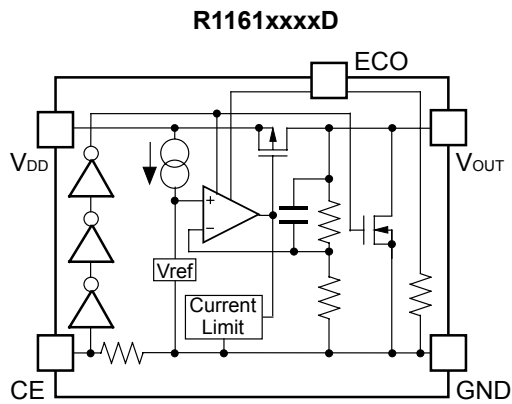
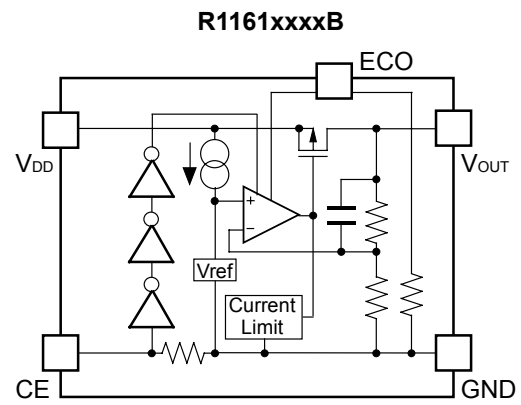
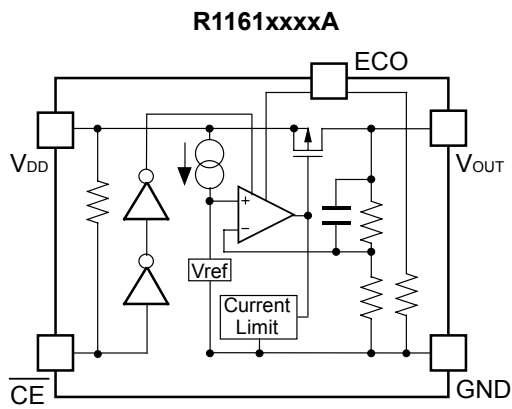
BLOCK DIAGRAM

SELECTION GUIDE

The output voltage, the chip enable polarity, package type, and the taping type for the ICs can be selected at the user's request. The selection can be available by designating the part number as shown below;

R1161xxxxx-xx ←Part Number
 ↑↑↑↑↑
 a b a'c d

Code	Contents
a, a'	Designation of Package Type : R1161Nxx1x-xx:SOT-23-5 (Mini-mold) R1161Dxx1x-xx:SON-6, R1161Dxx2x-xx:HSON-6
b	Setting Output Voltage (V_{OUT}) : Stepwise setting with a step of 0.1V in the range of 0.8V to 3.3V is possible.
c	Designation of Chip Enable Option : A:"L" active type. B:"H" active type. D:"H" active and with auto discharge function
d	Designation of Taping Type : TR Refer to Taping Specifications

PIN CONFIGURATIONS

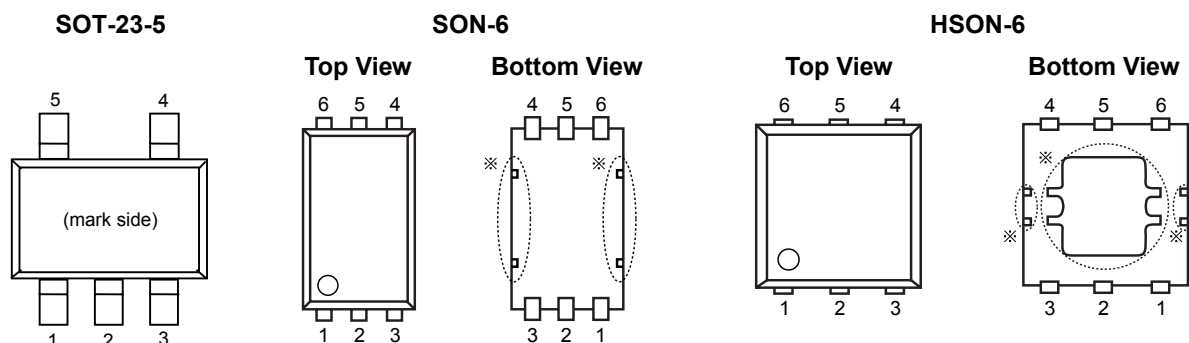

PIN DESCRIPTIONS

• SOT-23-5

Pin No	Symbol	Pin Description
1	V_{DD}	Input Pin
2	GND	Ground Pin
3	\overline{CE} or CE	Chip Enable Pin
4	ECO	MODE alternative pin
5	V_{OUT}	Output pin

SON-6, HSON-6

Pin No	Symbol	Pin Description
1	V_{DD}	Input Pin
2	NC	No Connection
3	V_{OUT}	Output pin
4	ECO	MODE alternative pin
5	GND	Ground Pin
6	\overline{CE} or CE	Chip Enable Pin

* Tab in the  parts have GND level.
(They are connected to the reverse side of this IC.)
Do not connect to other wires or land patterns.

ABSOLUTE MAXIMUM RATINGS

Symbol	Item	Rating	Unit
V_{IN}	Input Voltage	6.5	V
V_{ECO}	Input Voltage(ECO Pin)	-0.3 ~ 6.5	V
V_{CE}	Input Voltage(\overline{CE} /CE Pin)	-0.3 ~ 6.5	V
V_{OUT}	Output Voltage	-0.3 ~ $V_{IN}+0.3$	V
I_{OUT}	Output Current	350	mA
P_D	Power Dissipation(SOT23-5)*	420	mW
P_D	Power Dissipation(SON-6)*	500	
P_D	Power Dissipation(HSON-6)*	900	
T_{opt}	Operating Temperature Range	-40 ~ 85	°C
T_{stg}	Storage Temperature Range	-55 ~ 125	°C

*) For Power Dissipation, please refer to PACKAGE INFORMATION to be described.

ELECTRICAL CHARACTERISTICS

• R1161xxxxA

T_{opt}=25°C

Symbol	Item	Conditions	Min.	Typ.	Max.	Unit
V _{OUT}	Output Voltage	V _{IN} =Set V _{OUT} +1V, V _{ECO} =V _{IN} 1μA ≤ I _{OUT} ≤ 30mA ^{Note 1}	×0.98 (-30mV)		×1.02 (30mV)	V
		V _{IN} =Set V _{OUT} +1V, V _{ECO} =GND 1μA ≤ I _{OUT} ≤ 30mA ^{Note 2}	×0.97 (-45mV)		×1.03 (45mV)	V
I _{OUT}	Output Current	V _{IN} -V _{OUT} =1.0V	300			mA
ΔV _{OUT} / ΔI _{OUT}	Load Regulation(FT Mode)	V _{IN} =Set V _{OUT} +1V, V _{ECO} =V _{IN} 1mA ≤ I _{OUT} ≤ 300mA		40	70	mV
ΔV _{OUT} / ΔI _{OUT}	Load Regulation(LP Mode)	V _{IN} =Set V _{OUT} +1V, V _{ECO} =GND 1mA ≤ I _{OUT} ≤ 100mA		15	30	mV
V _{DIF}	Dropout Voltage	Refer to the ELECTRICAL CHARACTERISTICS by OUTPUT VOLTAGE				
I _{SS1}	Supply Current(FT Mode)	V _{IN} =Set V _{OUT} +1V V _{ECO} =V _{IN} , V _{OUT} <1.8V		80	111	μA
		V _{IN} =Set V _{OUT} +1V V _{ECO} =V _{IN} , V _{OUT} ≥ 1.8V		60	90	μA
I _{SS2}	Supply Current(LP Mode)	V _{IN} =Set V _{OUT} +1V, V _{OUT} <1.6V, V _{ECO} =GND		3.5	8.0	μA
		V _{IN} =Set V _{OUT} +1V V _{OUT} ≥ 1.6V, V _{ECO} =GND		4.5	9.0	μA
I _{standby}	Supply Current (Standby)	V _{IN} =V _{CE} =Set V _{OUT} +1V, V _{ECO} =GND		0.1	1.0	μA
ΔV _{OUT} / ΔV _{IN}	Line Regulation(FT Mode)	Set V _{OUT} +0.5V ≤ V _{IN} ≤ 6.0V I _{OUT} =30mA, V _{ECO} =V _{IN} Set V _{OUT} < 0.9V: 1.4V ≤ V _{IN} ≤ 6.0V		0.01	0.15	%/V
ΔV _{OUT} / ΔV _{IN}	Line Regulation(LP Mode)	Set V _{OUT} + 0.5V ≤ V _{IN} ≤ 6.0V I _{OUT} =30mA, V _{ECO} =GND Set V _{OUT} <0.9V:1.4V ≤ V _{IN} ≤ 6.0V		0.05	0.20	%/V
RR	Ripple Rejection(FT Mode)	f = 1kHz, Ripple 0.2Vp-p V _{IN} =Set V _{OUT} + 1V I _{OUT} =30mA, V _{ECO} =V _{IN}		65		dB
V _{IN}	Input Voltage		1.4		6.0	V
ΔV _{OUT} / ΔT _{opt}	Output Voltage Temperature Coefficient	I _{OUT} =30mA -40°C ≤ T _{opt} ≤ 85°C		±100		ppm /°C
I _{lim}	Short Current Limit	V _{OUT} =0V		50		mA
R _{PU}	\overline{CE} Pull-up Resistance		1.87	5.00	12.00	MΩ
R _{PD}	ECO Pull-down Resistance		1.87	5.00	12.00	MΩ
V _{CEH}	\overline{CE} , ECO Input Voltage "H"		1.0		6.0	V
V _{CEL}	\overline{CE} , ECO Input Voltage "L"		0.0		0.3	V
V _{EN}	Output Noise	BW=10Hz to 100kHz		30		μVrms

Note1: ±30mV tolerance for V_{OUT} ≤ 1.5V.

Note2: ±45mV tolerance for V_{OUT} ≤ 1.5V.

R1161x

• R1161xxxxB

Topt=25°C

Symbol	Item	Conditions	Min.	Typ.	Max.	Unit
V _{OUT}	Output Voltage	V _{IN} =Set V _{OUT} +1V, V _{ECO} =V _{IN} 1μA ≤ I _{OUT} ≤ 30mA ^{Note 1}	×0.98 (-30mV)		×1.02 (30mV)	V
		V _{IN} =Set V _{OUT} +1V, V _{ECO} =GND 1μA ≤ I _{OUT} ≤ 30mA ^{Note 2}	×0.97 (-45mV)		×1.03 (45mV)	V
I _{OUT}	Output Current	V _{IN} -V _{OUT} =1.0V	300			mA
ΔV _{OUT} / ΔI _{OUT}	Load Regulation(FT Mode)	V _{IN} =Set V _{OUT} +1V, V _{ECO} =V _{IN} 1mA ≤ I _{OUT} ≤ 300mA		40	70	mV
ΔV _{OUT} / ΔI _{OUT}	Load Regulation(LP Mode)	V _{IN} =Set V _{OUT} +1V, V _{ECO} =GND 1mA ≤ I _{OUT} ≤ 100mA		15	30	mV
V _{DIF}	Dropout Voltage	Refer to the ELECTRICAL CHARACTERISTICS by OUTPUT VOLTAGE				
I _{SS1}	Supply Current(FT Mode)	V _{IN} =Set V _{OUT} +1V V _{ECO} =V _{IN} , V _{OUT} <1.8V		80	111	μA
		V _{IN} =Set V _{OUT} +1V V _{ECO} =V _{IN} , V _{OUT} ≥ 1.8V		60	90	μA
I _{SS2}	Supply Current(LP Mode)	V _{IN} =Set V _{OUT} +1V, V _{OUT} <1.6V, V _{ECO} =GND		3.5	8.0	μA
		V _{IN} =Set V _{OUT} +1V, V _{OUT} ≥ 1.6V, V _{ECO} =GND		4.5	9.0	μA
I _{standby}	Supply Current (Standby)	V _{IN} =Set V _{OUT} +1V, V _{CE} =GND, V _{ECO} =GND		0.1	1.0	μA
ΔV _{OUT} / ΔV _{IN}	Line Regulation(FT Mode)	Set V _{OUT} +0.5V ≤ V _{IN} ≤ 6.0V I _{OUT} =30mA, V _{ECO} =V _{IN} Set V _{OUT} <0.9V: 1.4V ≤ V _{IN} ≤ 6.0V		0.01	0.15	%/V
ΔV _{OUT} / ΔV _{IN}	Line Regulation(LP Mode)	Set V _{OUT} +0.5V ≤ V _{IN} ≤ 6.0V I _{OUT} =30mA, V _{ECO} =GND Set V _{OUT} <0.9V: 1.4V ≤ V _{IN} ≤ 6.0V		0.05	0.20	%/V
RR	Ripple Rejection(FT Mode)	f=1kHz, Ripple 0.2Vp-p V _{IN} =Set V _{OUT} +1V I _{OUT} =30mA, V _{ECO} =V _{IN}		65		dB
V _{IN}	Input Voltage		1.4		6.0	V
ΔV _{OUT} / ΔT _{opt}	Output Voltage Temperature Coefficient	I _{OUT} =30mA -40°C ≤ T _{opt} ≤ 85°C		±100		ppm /°C
I _{lim}	Short Current Limit	V _{OUT} =0V		50		mA
R _{PD}	CE Pull-down Resistance		1.87	5.00	12.00	MΩ
R _{PDE}	ECO Pull-down Resistance		1.87	5.00	12.00	MΩ
V _{CEH}	CE, ECO Input Voltage "H"		1.0		6.0	V
V _{CEL}	CE, ECO Input Voltage "L"		0.0		0.3	V
V _{EN}	Output Noise	BW=10Hz to 100kHz		30		μVrms
R _{LOW}	Nch On Resistance for auto discharge (applied to D version only)	V _{CE} =0V		60		Ω

Note1: ±30mV tolerance for V_{OUT} ≤ 1.5V.

Note2: ±45mV tolerance for V_{OUT} ≤ 1.5V.

ELECTRICAL CHARACTERISTICS by OUTPUT VOLTAGE

T_{opt}=25°C

Output Voltage V _{OUT} (V)	Dropout Voltage				
	Condition	V _{DIF} (V)			
		V _{DIF} (ECO=H)		V _{DIF} (ECO=L)	
		Typ.	Max.	Typ.	Max.
0.8=V _{OUT}	I _{OUT} =300mA	0.620	0.850	0.670	0.900
0.9=V _{OUT}		0.550	0.780	0.590	0.800
1.0 ≤ V _{OUT} < 1.5		0.480	0.700	0.510	0.750
1.5 ≤ V _{OUT} < 2.6		0.310	0.450	0.320	0.480
2.6 ≤ V _{OUT}		0.230	0.350	0.240	0.375

TEST CIRCUITS

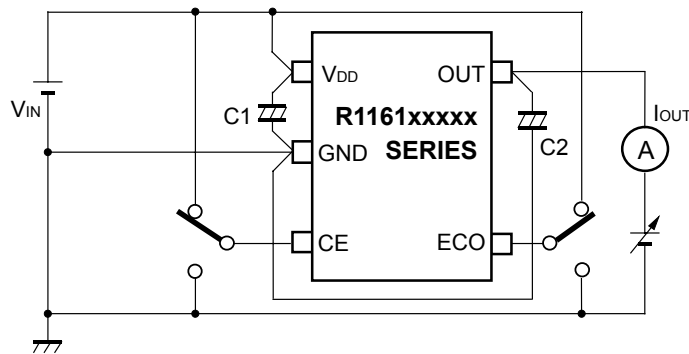

Fig.1 Output Voltage vs. Output Current Test Circuit

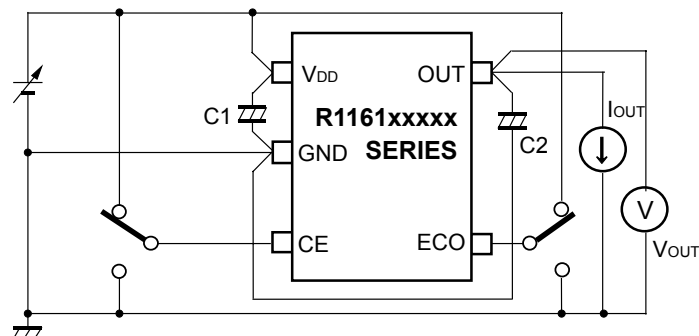

Fig.2 Output Voltage vs. Input Voltage Test Circuit

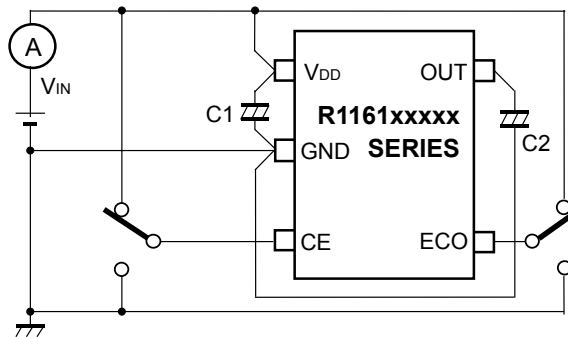

Fig.3 Supply Current vs. Input Voltage Test Circuit

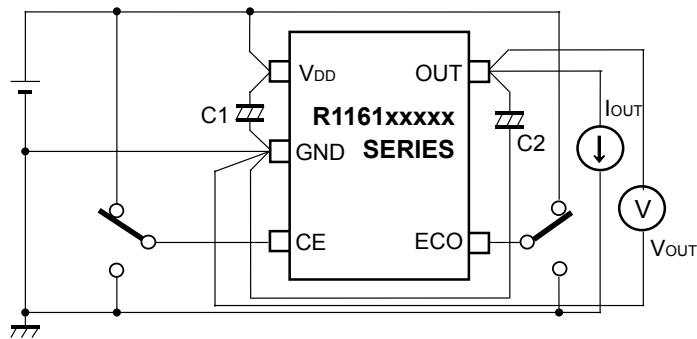

Fig.4 Output Voltage vs. Temperature Test Circuit

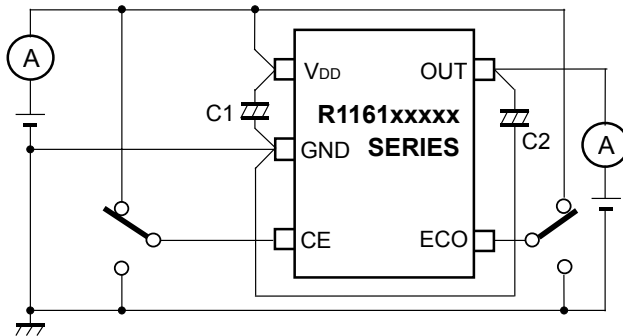

Fig.5 Supply Current vs. Temperature Test Circuit

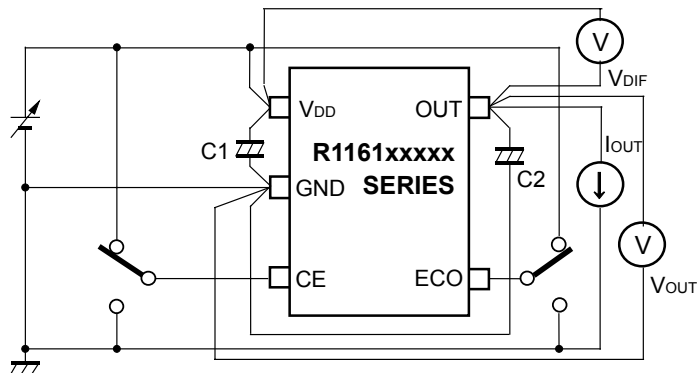

Fig. 6 Dropout Voltage vs. Output Current/ Set Output Voltage Test Circuit

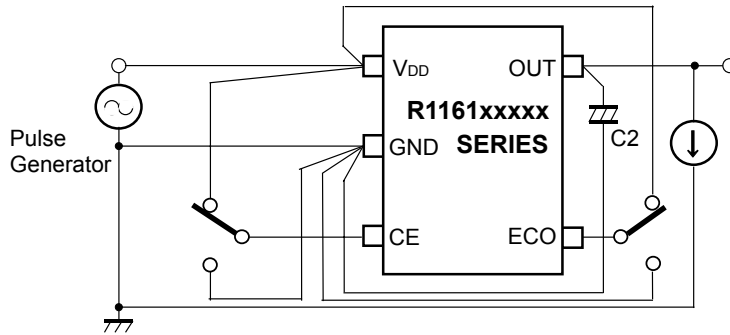

Fig. 7 Ripple Rejection Test Circuit

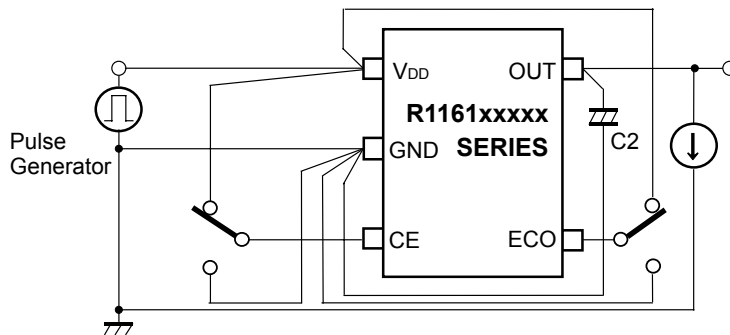

Fig.8 Input Transient Response Test Circuit

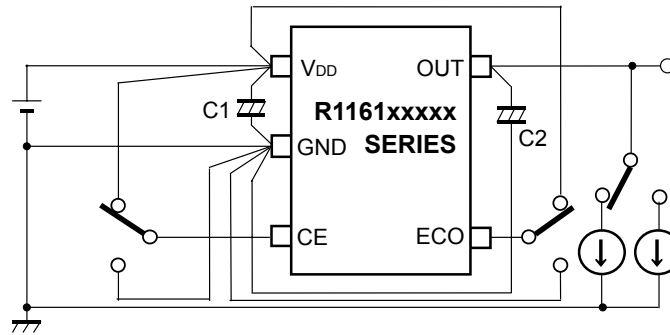

Fig.9 Load Transient Response Test Circuit

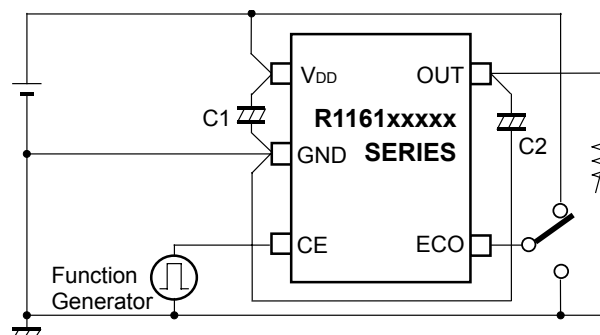

Fig.10 Turn on Speed with CE pin Test Circuit

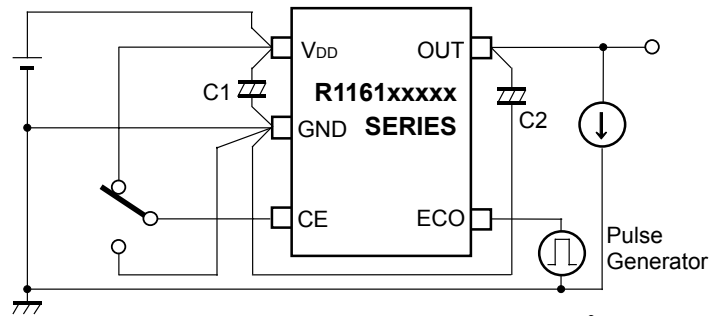

Fig.11 MODE Transient Response Test Circuit

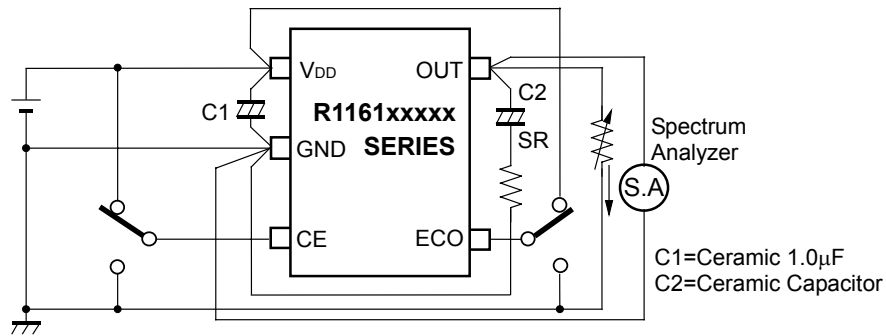
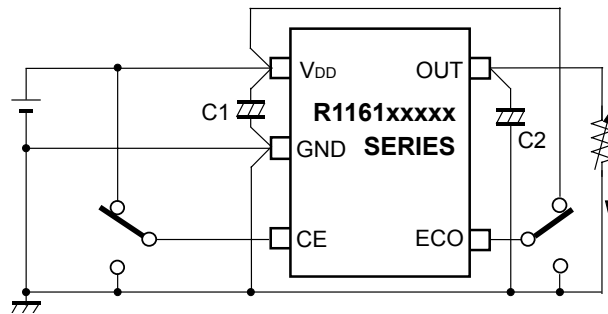

Fig.12 Output Noise Test Circuit(IOUT vs. ESR)

TYPICAL APPLICATION



(External Components)

Output Capacitor; 1.0 μ F or more capacity ceramic Type (If VOUT<1.0V, Tantalum type is recommended)

Input Capacitor; 1.0 μ F or more capacity ceramic Type

TYPICAL CHARACTERISTICS

1) Output Voltage vs. Output Current

R1161x08xx (ECO=H)

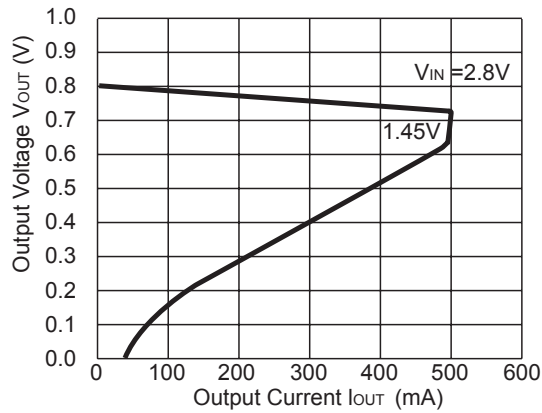

R1161x08xx (ECO=L)

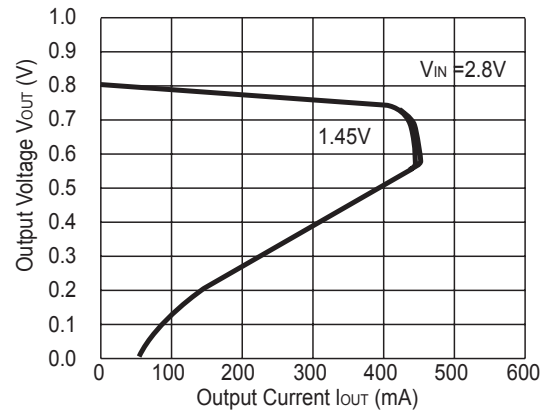

R1161x15xx (ECO=H)

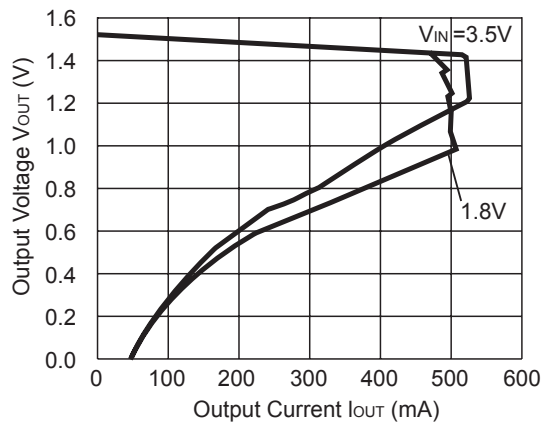

R1161x15xx (ECO=L)

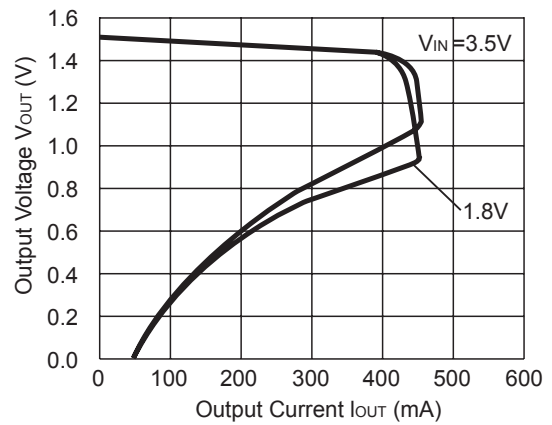

R1161x26xx (ECO=H)

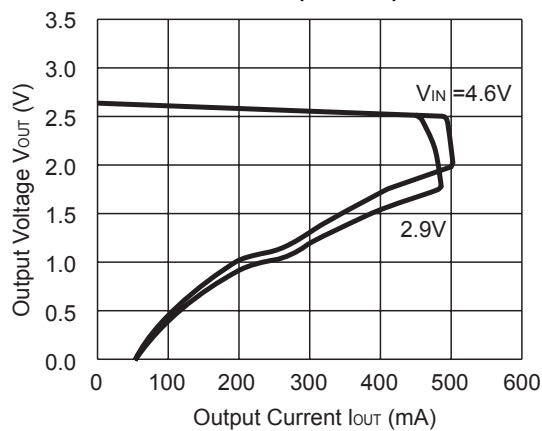

R1161x26xx (ECO=L)

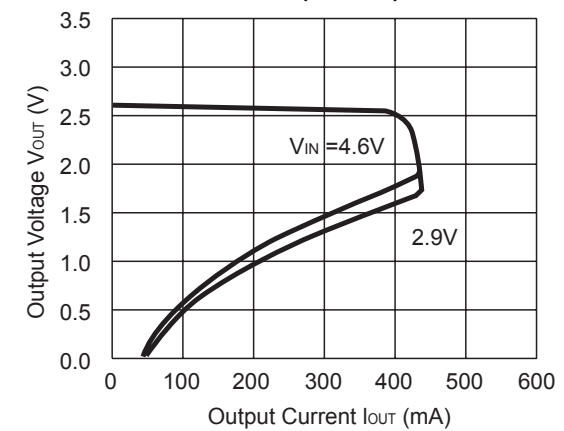

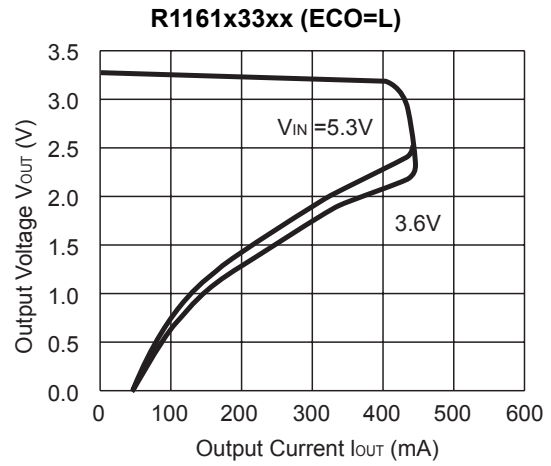
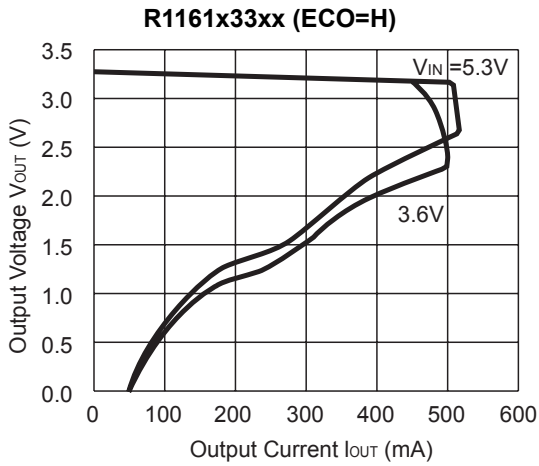

2) Output Voltage vs. Input Voltage

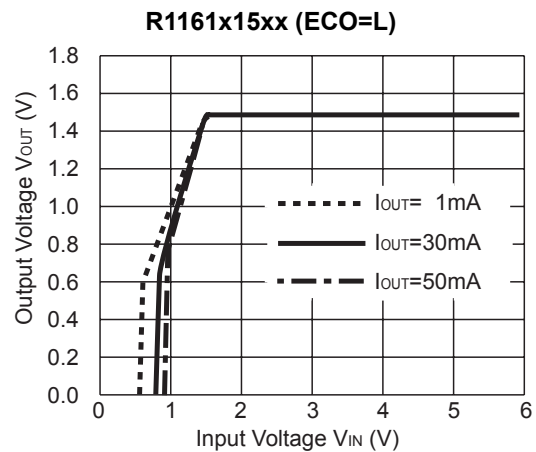
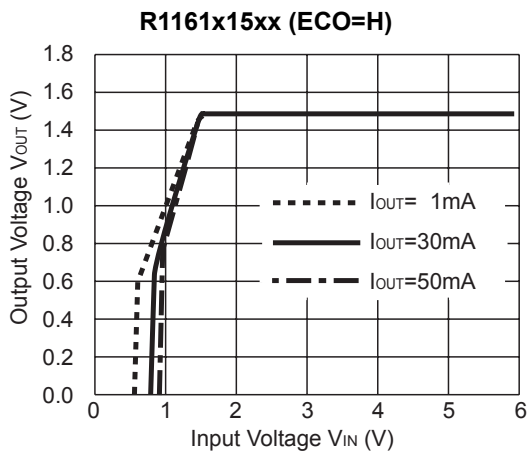
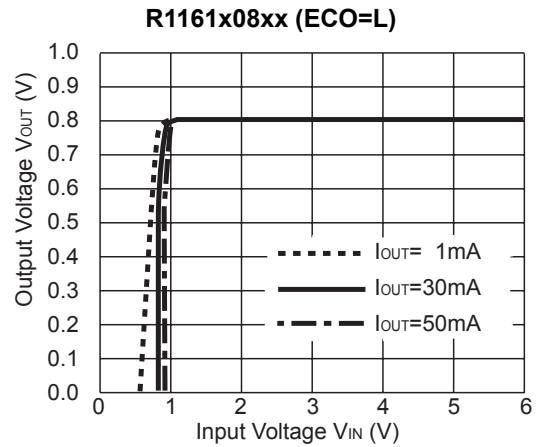
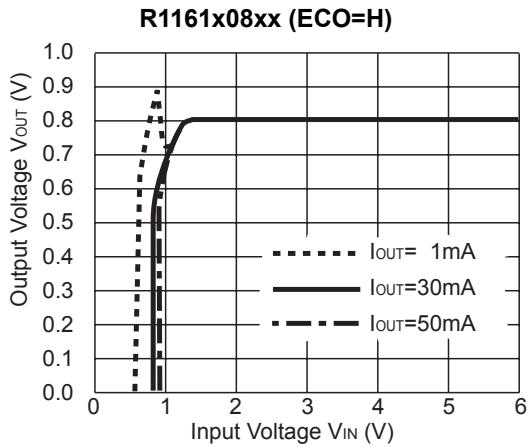

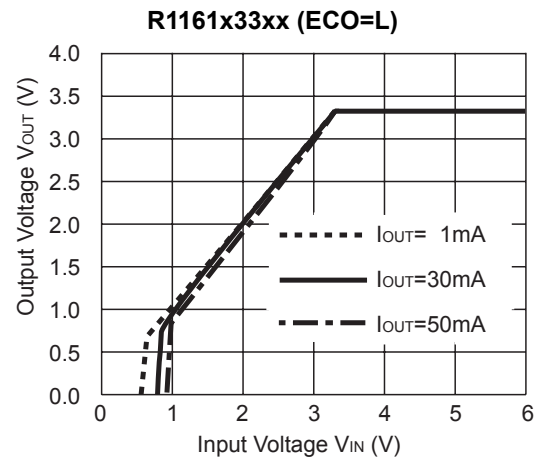
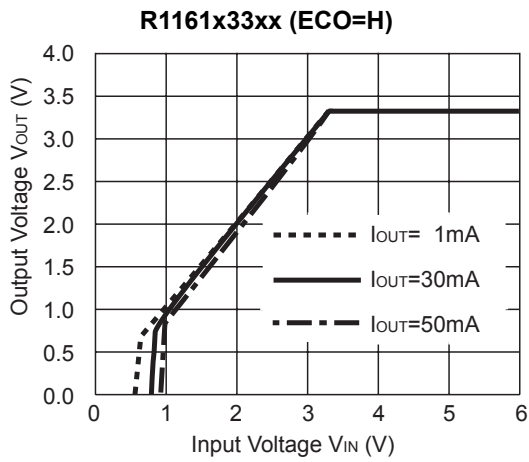
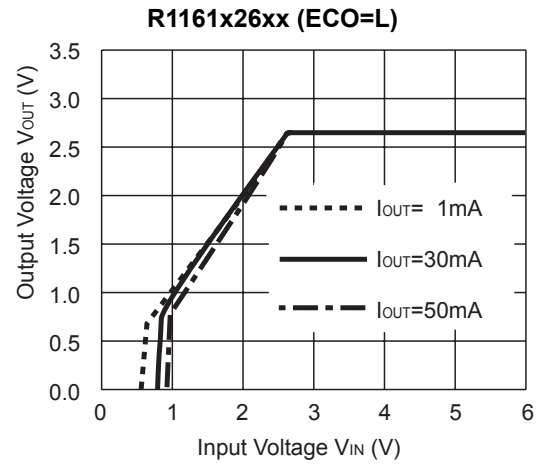
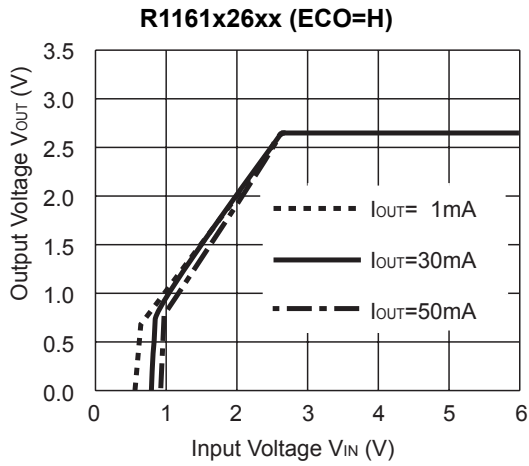

3) Supply Current vs. Input Voltage

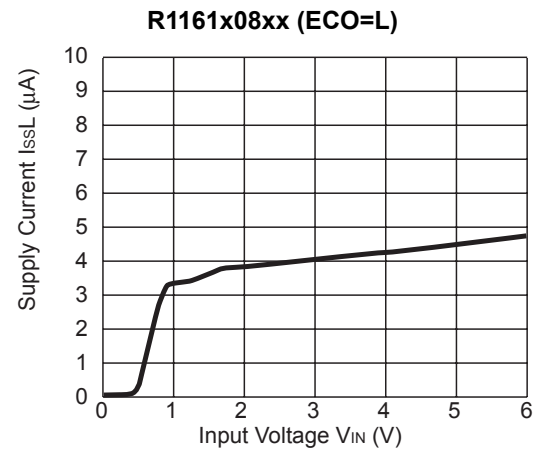
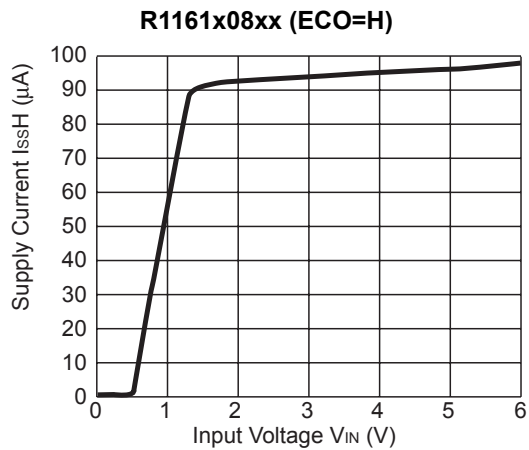

R1161x15xx (ECO=H)

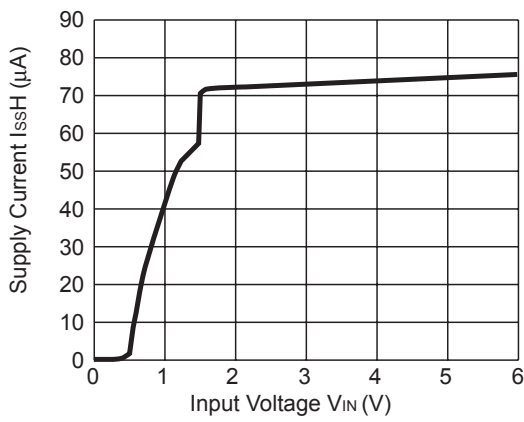

R1161x15xx (ECO=L)

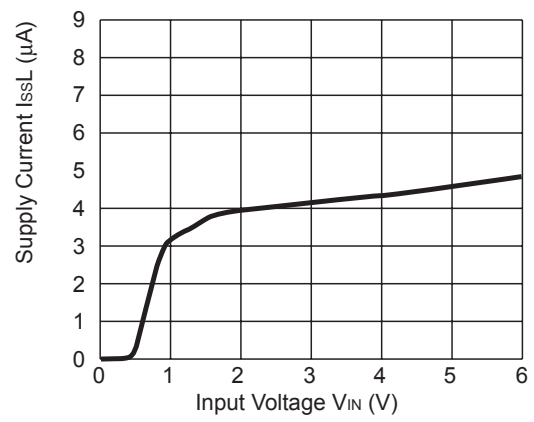

R1161x26xx (ECO=H)

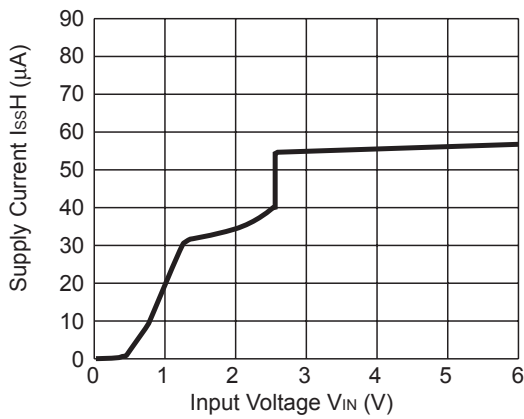

R1161x26xx (ECO=L)

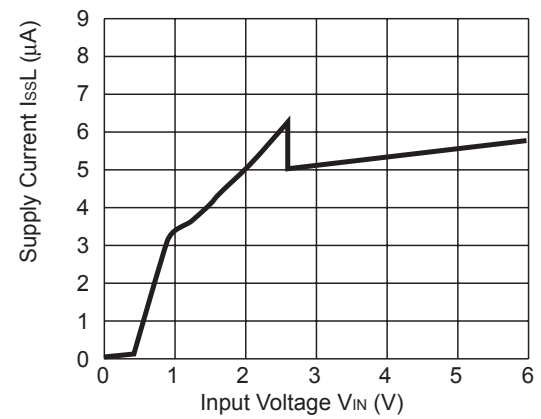

R1161x33xx (ECO=H)

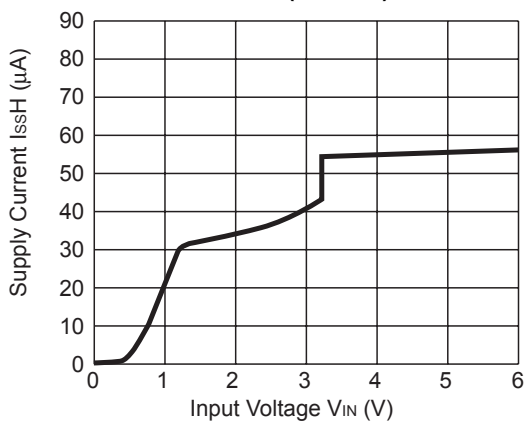

R1161x33xx (ECO=L)

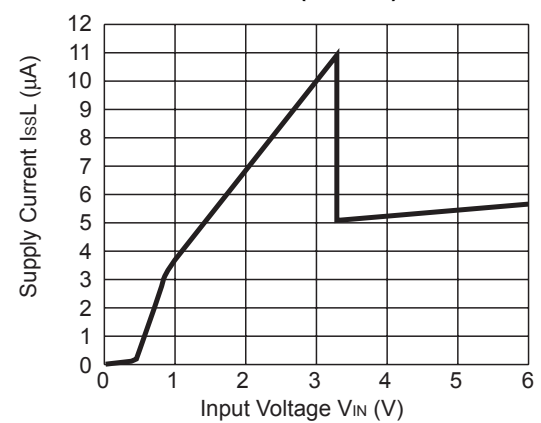

4) Output Voltage vs. Temperature

R1161x08xx (ECO=H)

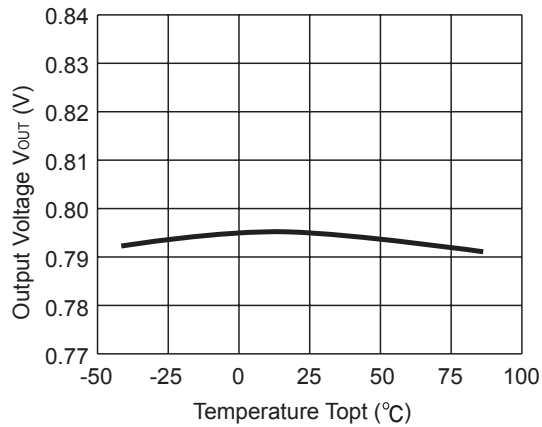

R1161x08xx (ECO=L)

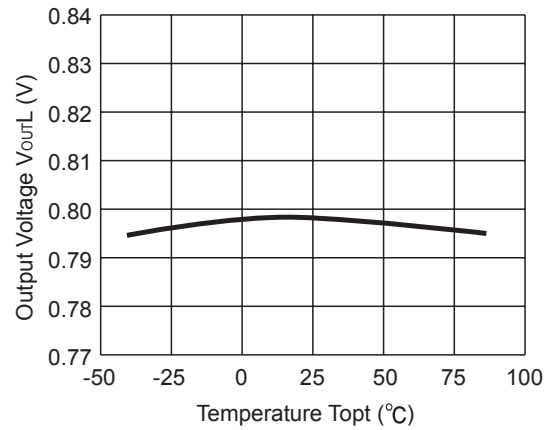

R1161x15xx (ECO=H)

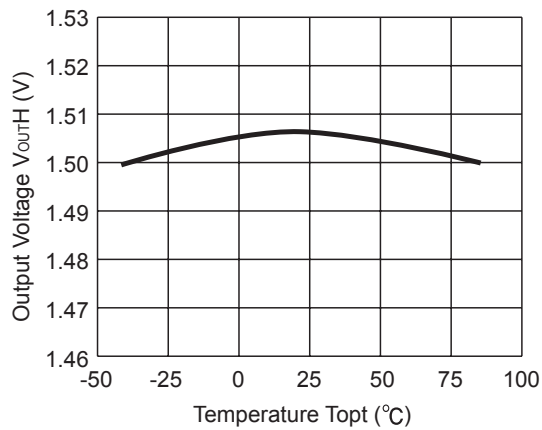

R1161x15xx (ECO=L)

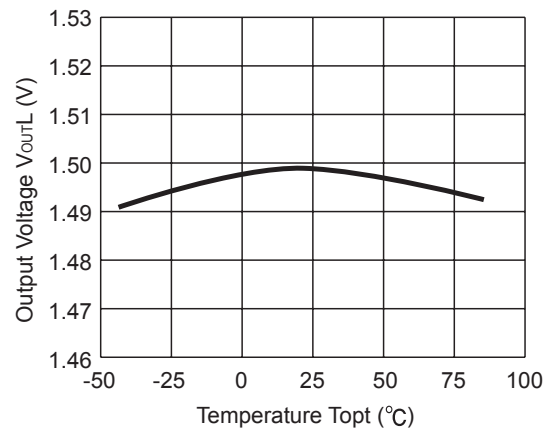

R1161x26xx (ECO=H)

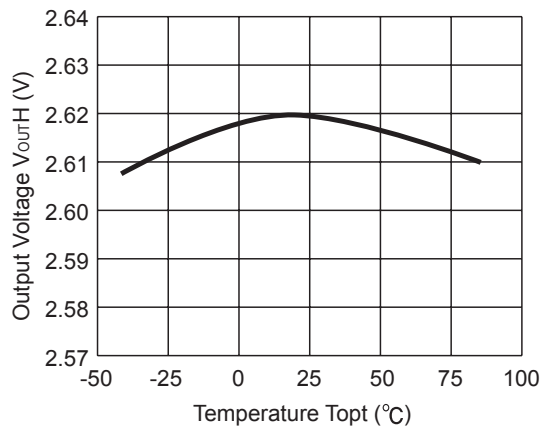

R1161x26xx (ECO=L)

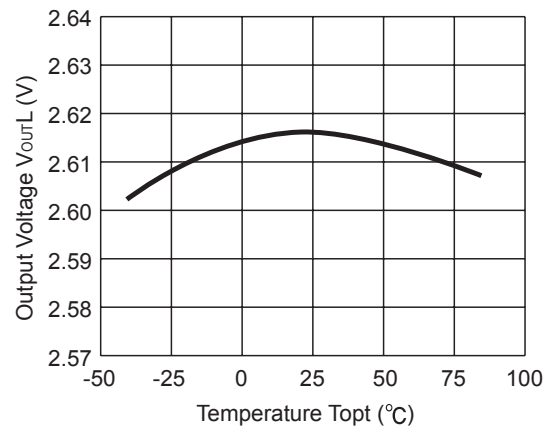

R1161x

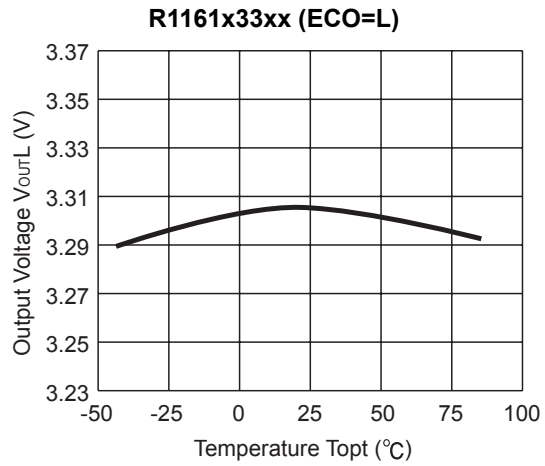
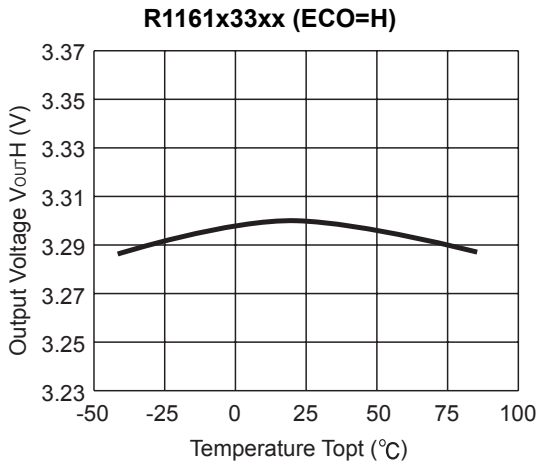

5) Supply Current vs. Temperature

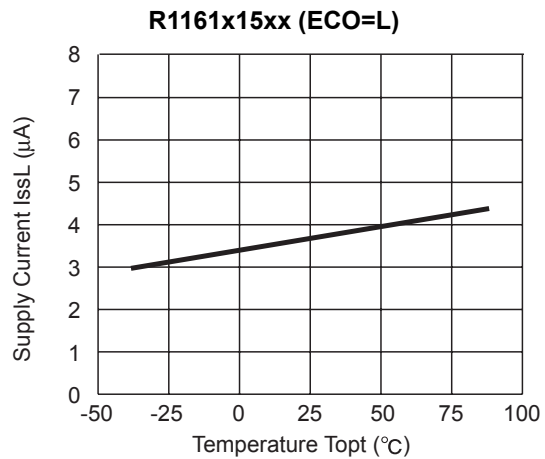
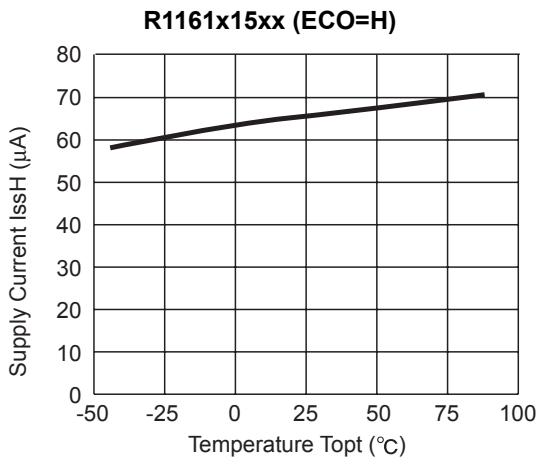
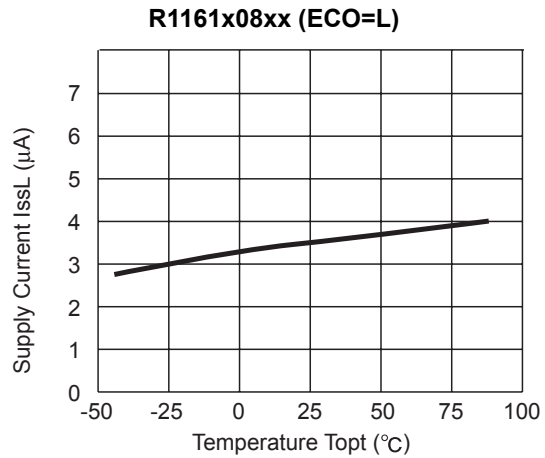
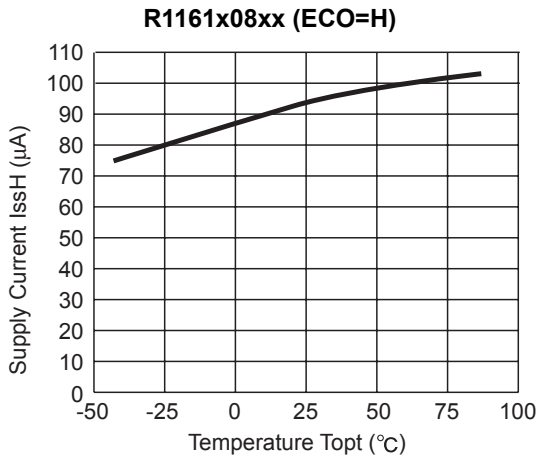

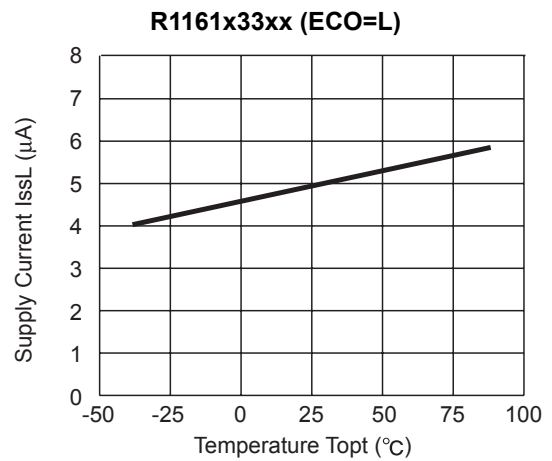
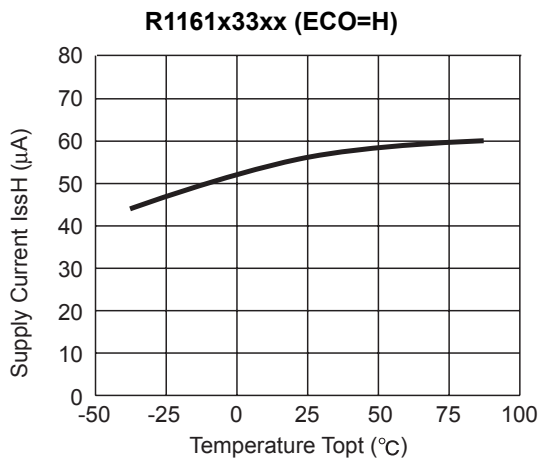
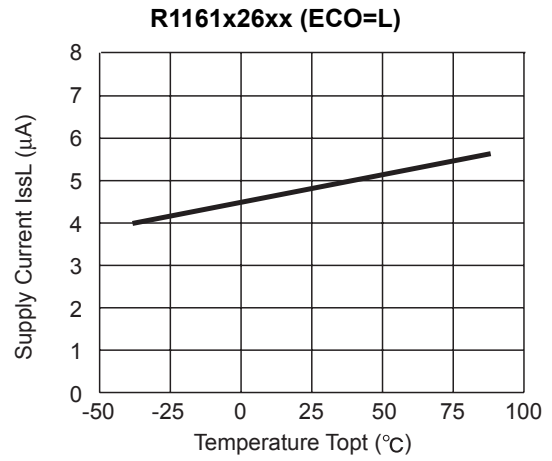
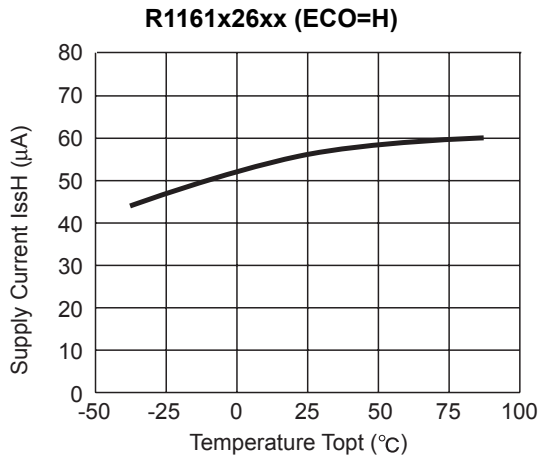

6) Dropout Voltage vs. Output Current

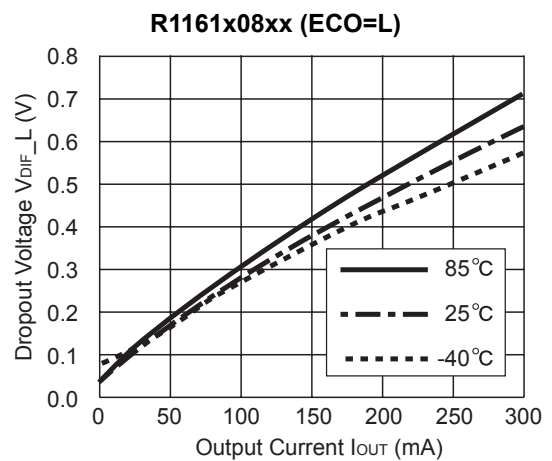
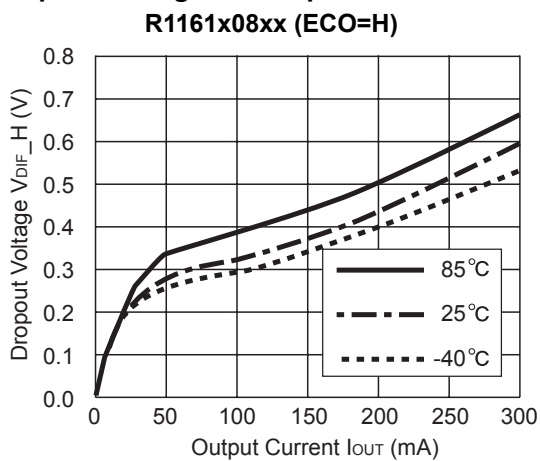

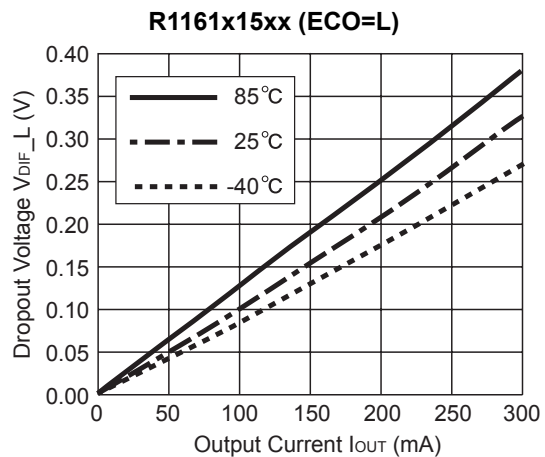
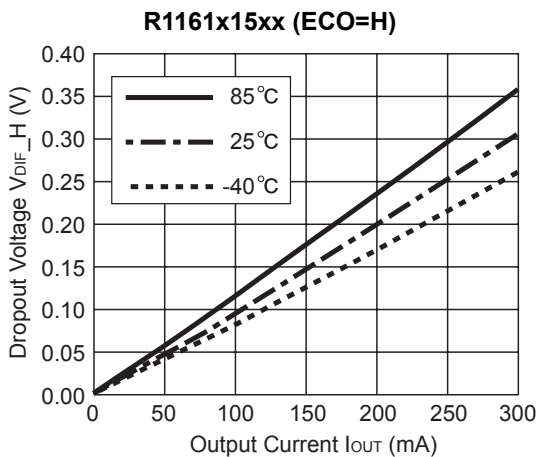
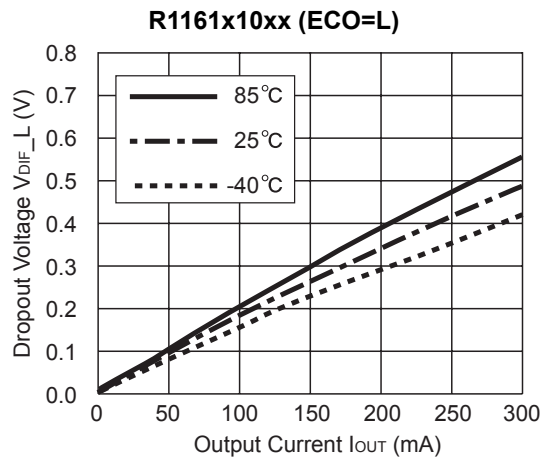
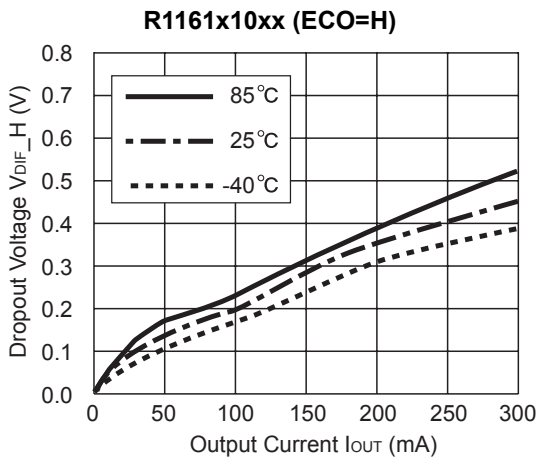
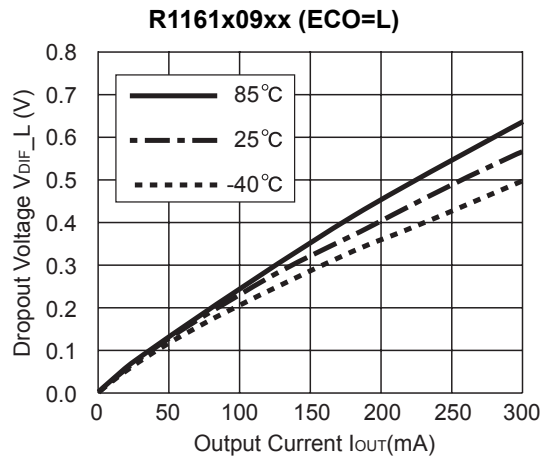
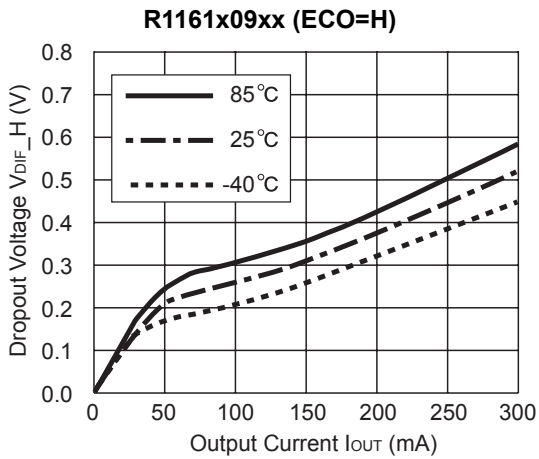

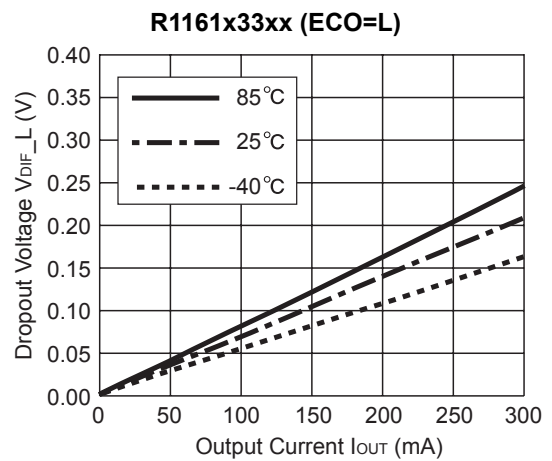
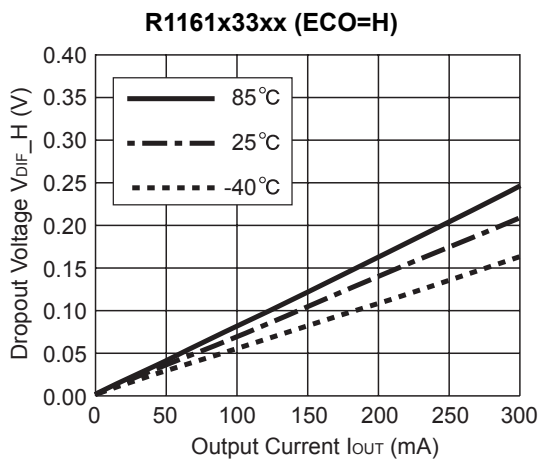
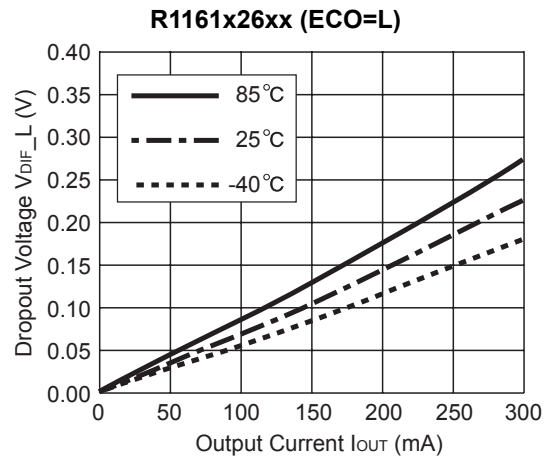
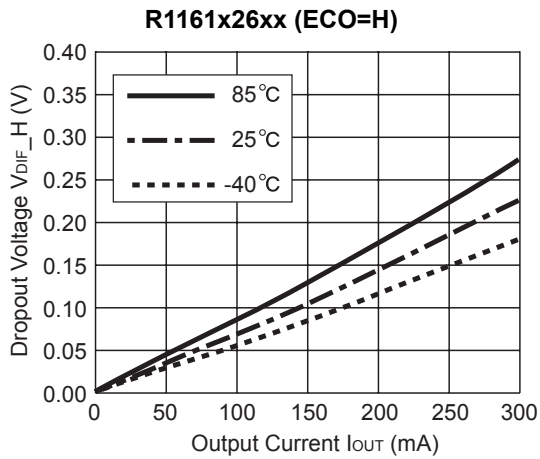

7) Dropout Voltage vs. Set Output Voltage (T_{opt}=25°C)

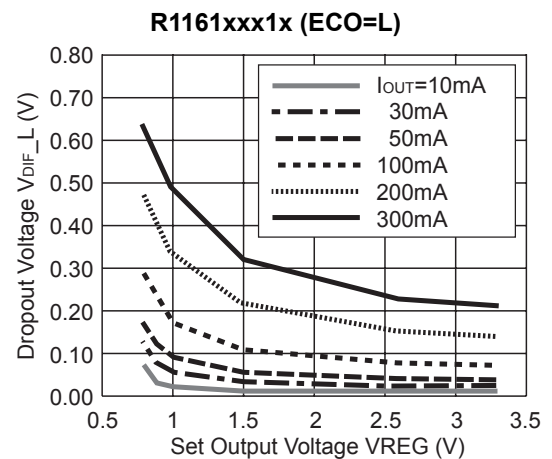
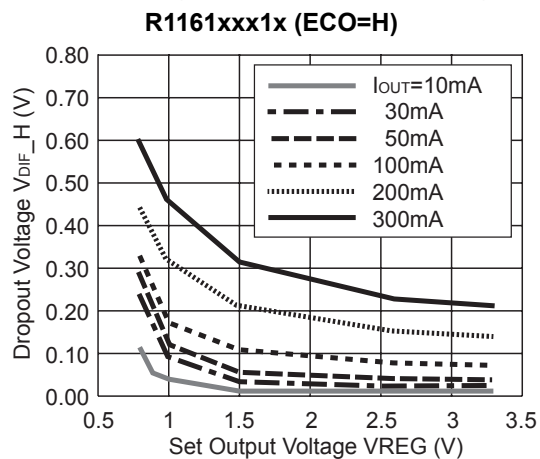

8) Ripple Rejection vs. Input Bias (Topt=25°C CIN=none, COUT=Ceramic 1.0μF Ripple 0.2Vp-p)

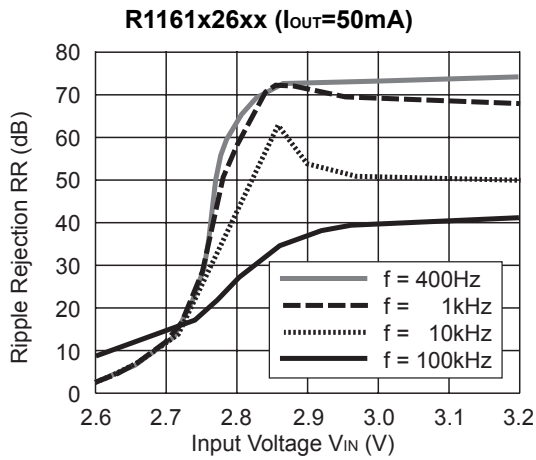
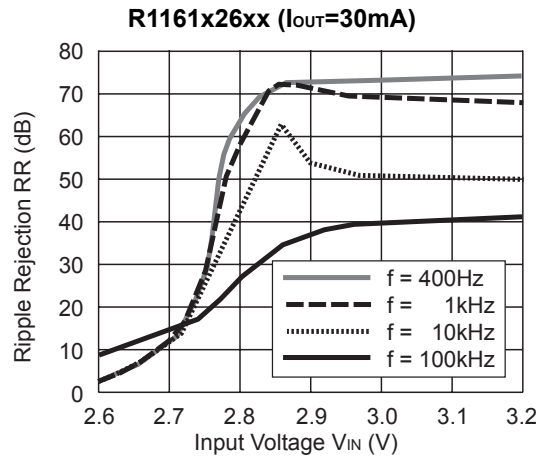
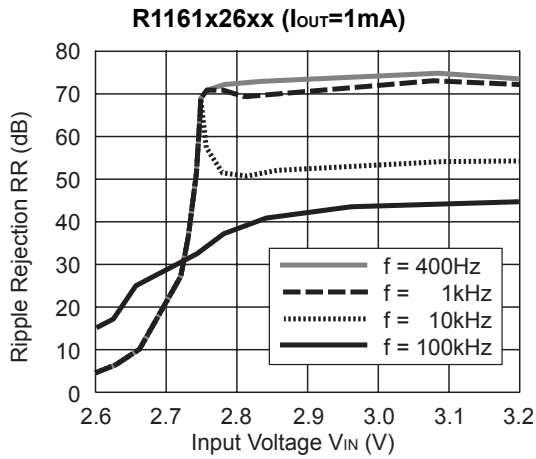

9) Ripple Rejection vs. Frequency (CIN=none)

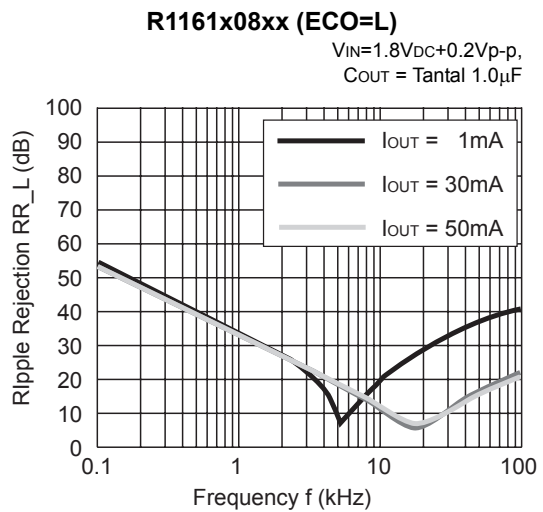
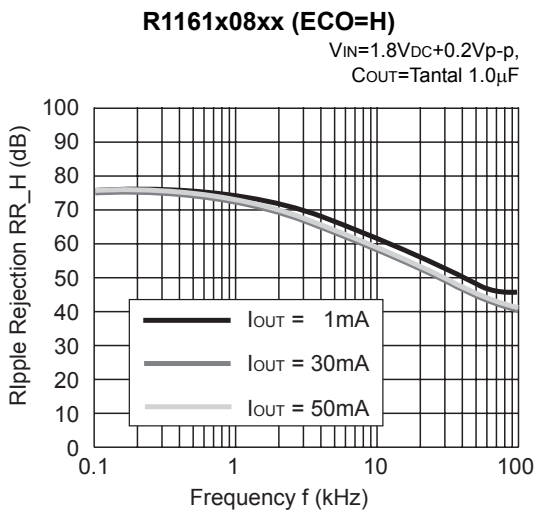

R1161x08xx (ECO=H)

$V_{IN}=1.8V_{DC}+0.2V_{p-p}$,
 $C_{OUT}=\text{Tantal } 2.2\mu\text{F}$

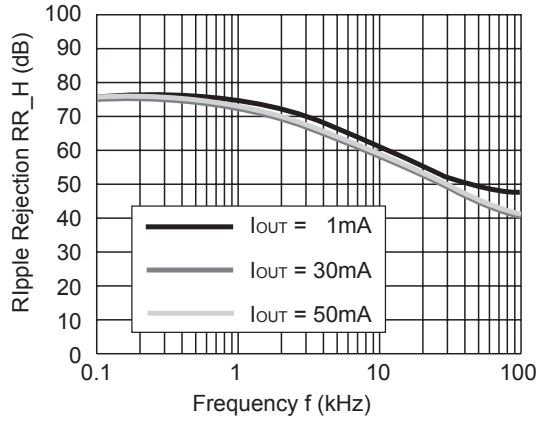

R1161x08xx (ECO=L)

$V_{IN}=1.8V_{DC}+0.2V_{p-p}$,
 $C_{OUT} = \text{Tantal } 2.2\mu\text{F}$

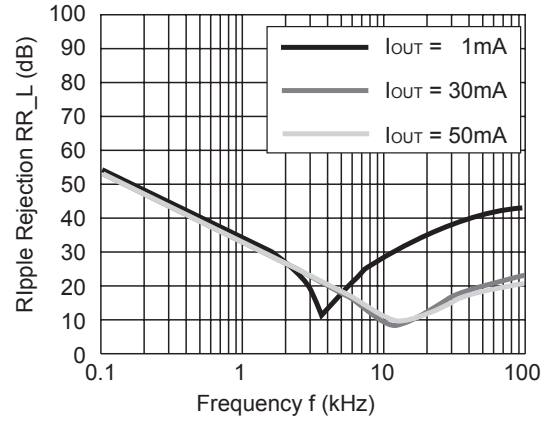

R1161x10xx (ECO=H)

$V_{IN}=2.0V_{DC}+0.2V_{p-p}$,
 $C_{OUT}=\text{Ceramic } 1.0\mu\text{F}$

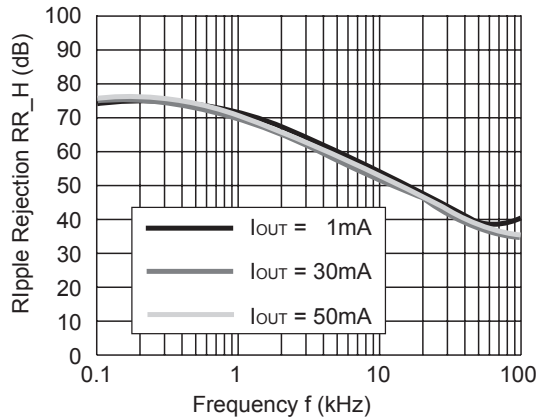

R1161x10xx (ECO=L)

$V_{IN}=2.0V_{DC}+0.2V_{p-p}$,
 $C_{OUT}=\text{Ceramic } 1.0\mu\text{F}$

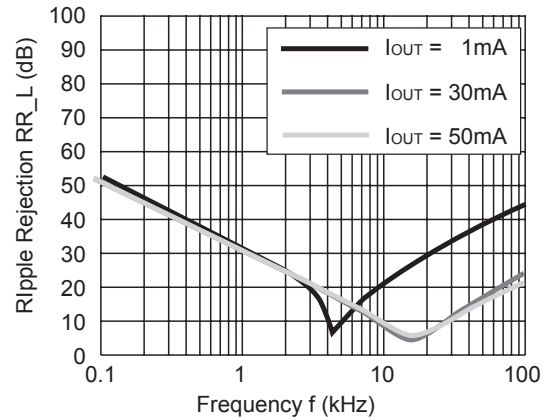

R1161x10xx (ECO=H)

$V_{IN}=2.0V_{DC}+0.2V_{p-p}$,
 $C_{OUT}=\text{Ceramic } 2.2\mu\text{F}$

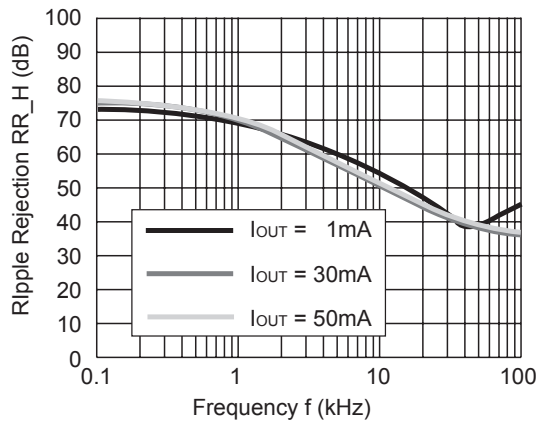

R1161x10xx (ECO=L)

$V_{IN}=2.0V_{DC}+0.2V_{p-p}$,
 $C_{OUT}=\text{Ceramic } 2.2\mu\text{F}$

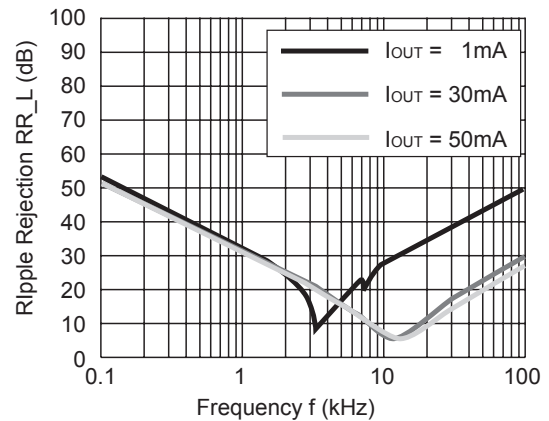

R1161x15xx (ECO=H)

$V_{IN}=2.5V_{DC}+0.2V_{p-p}$,
 $C_{OUT}=1.0\mu F$

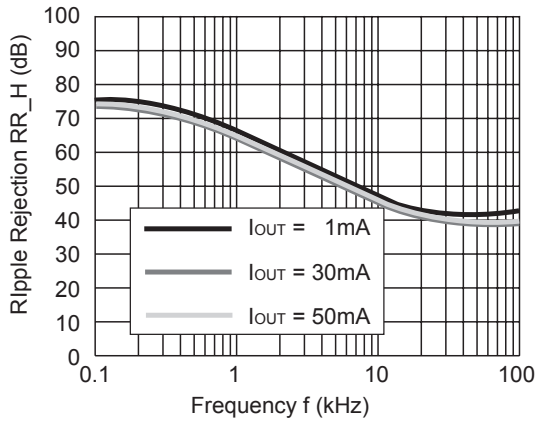

R1161x15xx (ECO=L)

$V_{IN}=2.5V_{DC}+0.2V_{p-p}$,
 $C_{OUT}=1.0\mu F$

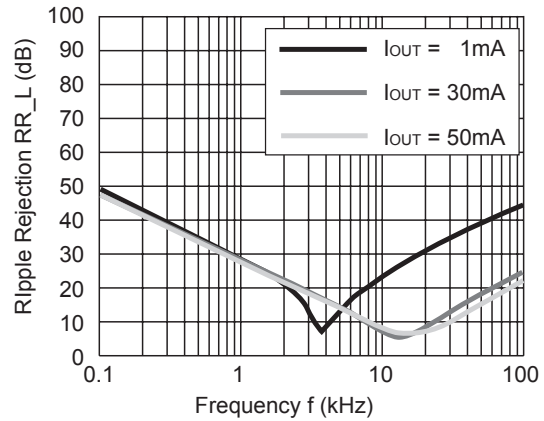

R1161x15xx (ECO=H)

$V_{IN}=2.5V_{DC}+0.2V_{p-p}$,
 $C_{OUT}=2.2\mu F$

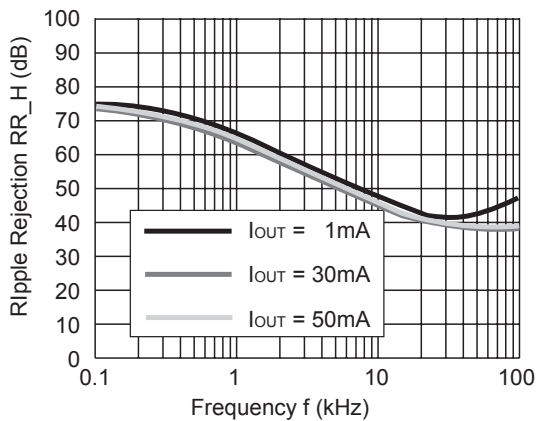

R1161x15xx (ECO=L)

$V_{IN}=2.5V_{DC}+0.2V_{p-p}$,
 $C_{OUT}=2.2\mu F$

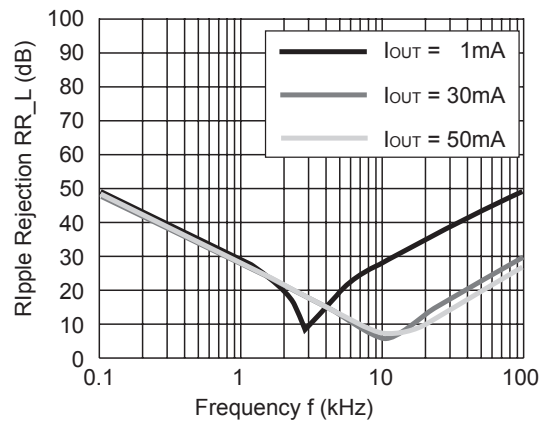

R1161x26xx (ECO=H)

$V_{IN}=3.6V_{DC}+0.2V_{p-p}$,
 $C_{OUT} = \text{Ceramic } 1.0\mu F$

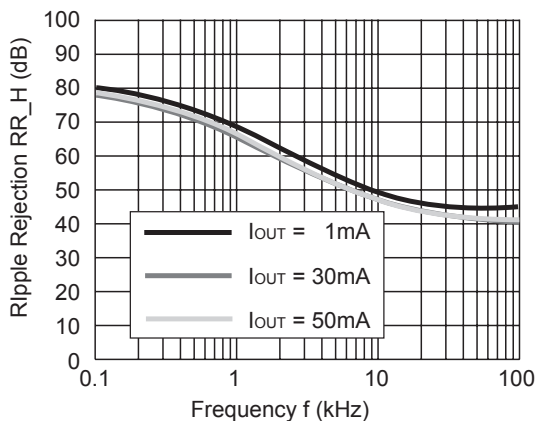

R1161x26xx (ECO=L)

$V_{IN}=3.6V_{DC}+0.2V_{p-p}$,
 $C_{OUT} = \text{Ceramic } 1.0\mu F$

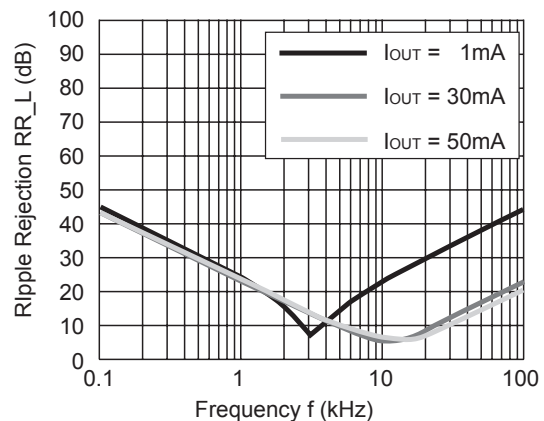

R1161x26xx (ECO=H)

$V_{IN}=3.6V_{DC}+0.2V_{p-p}$,
 $C_{OUT} = \text{Ceramic } 2.2\mu\text{F}$

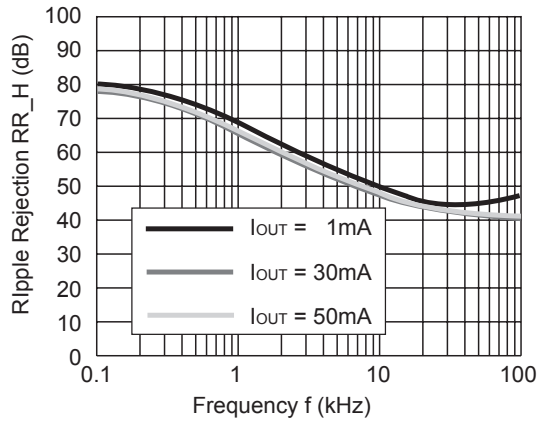

R1161x26xx (ECO=L)

$V_{IN}=3.6V_{DC}+0.2V_{p-p}$,
 $C_{OUT} = \text{Ceramic } 2.2\mu\text{F}$

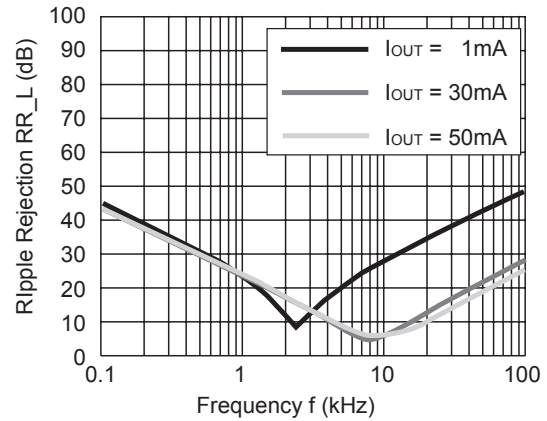

R1161x33xx (ECO=H)

$V_{IN}=4.3V_{DC}+0.2V_{p-p}$,
 $C_{OUT} = \text{Ceramic } 1.0\mu\text{F}$

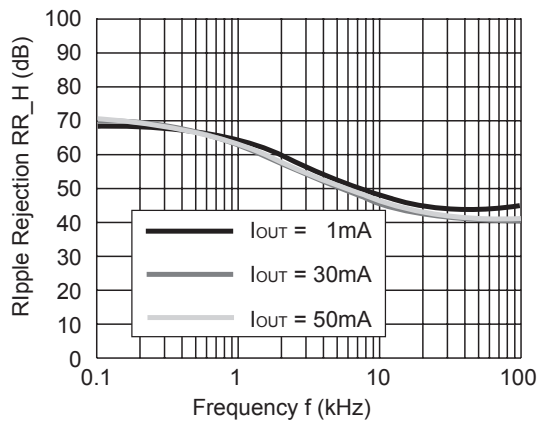

R1161x33xx (ECO=L)

$V_{IN}=4.3V_{DC}+0.2V_{p-p}$,
 $C_{OUT} = \text{Ceramic } 1.0\mu\text{F}$

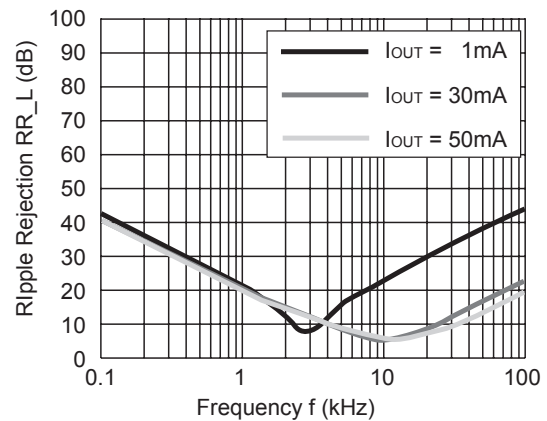

R1161x33xx (ECO=H)

$V_{IN}=4.3V_{DC}+0.2V_{p-p}$,
 $C_{OUT} = \text{Ceramic } 2.2\mu\text{F}$

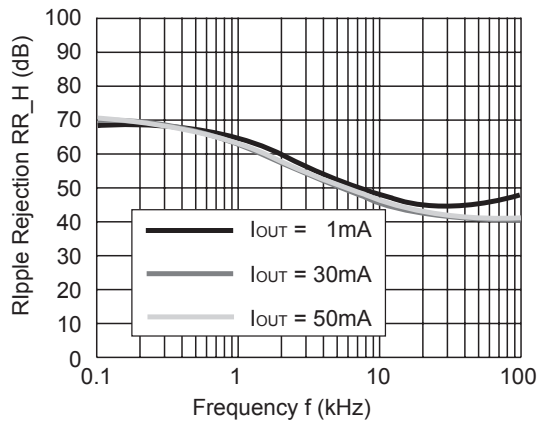

R1161x33xx (ECO=L)

$V_{IN}=4.3V_{DC}+0.2V_{p-p}$,
 $C_{OUT} = \text{Ceramic } 2.2\mu\text{F}$

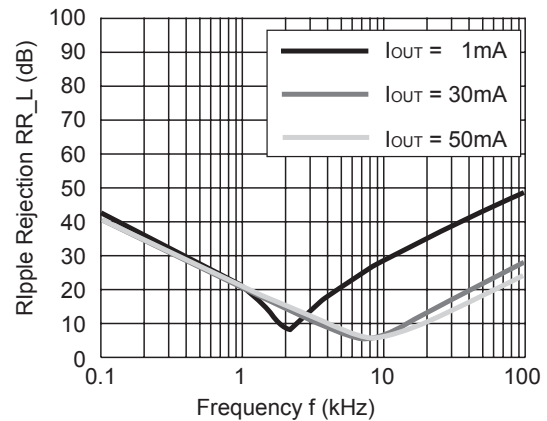

10) Input Transient Response ($C_{IN} = \text{none}$, $t_r=t_f=5\mu\text{s}$)

R1161x08xx (ECO=H)

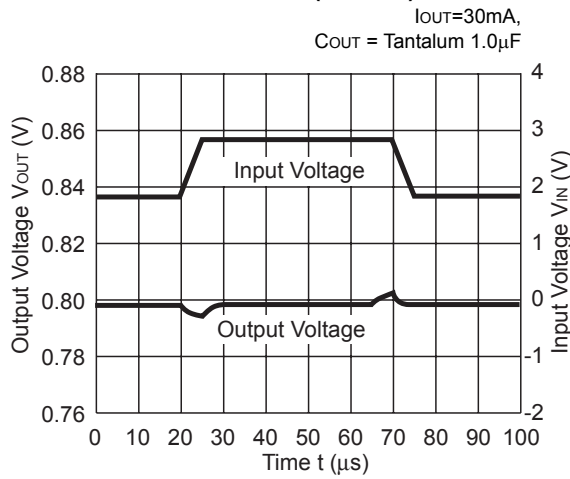

R1161x08x (ECO=L)

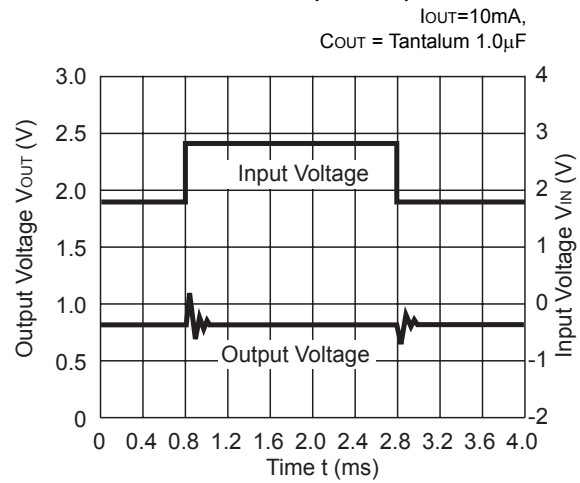

R1161x10xx (ECO=H)

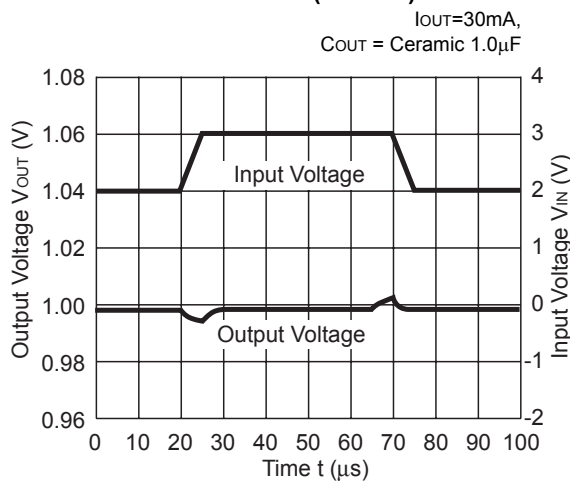

R1161x10xx (ECO=L)

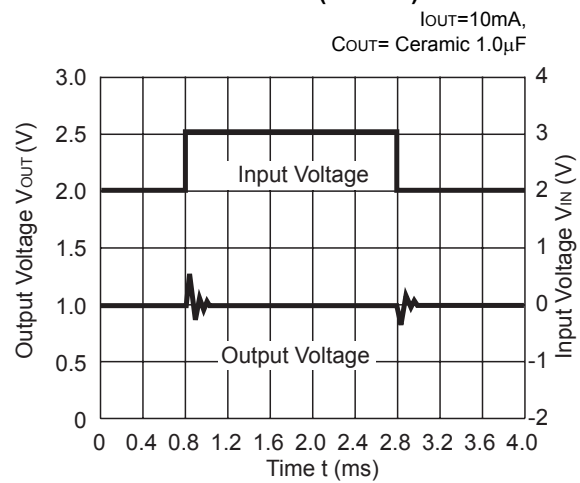

R1161x26xx (ECO=H)

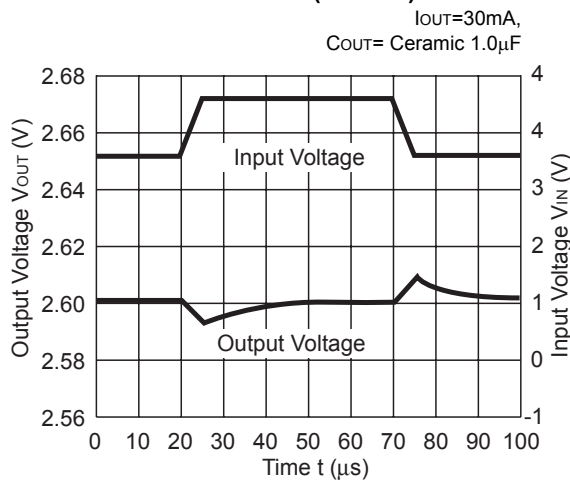

R1161x26xx (ECO=L)

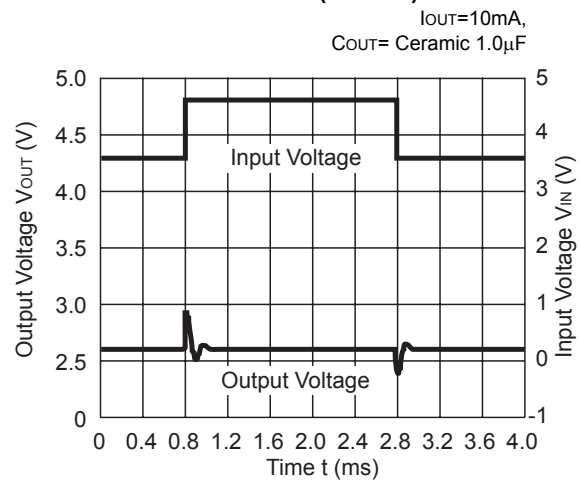

11) Load Transient Response ($t_r=t_f=0.5\mu s$)

R1161x08xx (ECO=H)

$V_{IN}=1.8V$
 $C_{IN} = \text{tantalum } 1.0\mu F, C_{OUT} = \text{tantalum } 1.0\mu F$

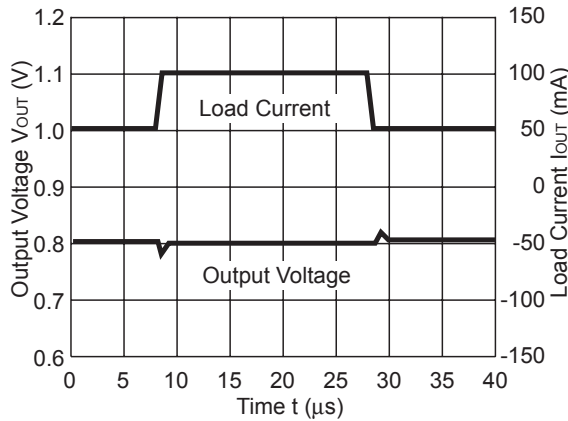

R1161x08xx (ECO=H)

$V_{IN}=1.8V$
 $C_{IN} = \text{tantalum } 1.0\mu F, C_{OUT} = \text{tantalum } 1.0\mu F$

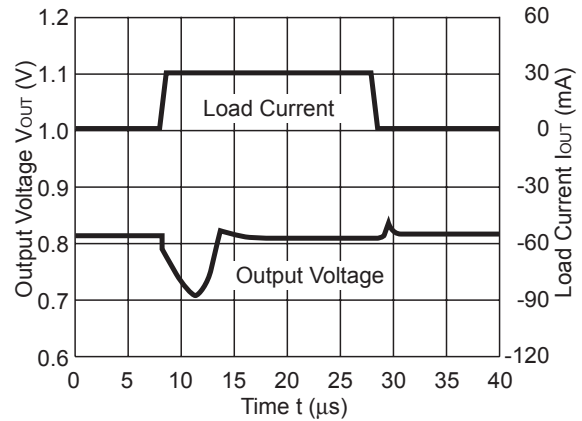

R1161x08xx (ECO=H)

$V_{IN}=1.8V$,
 $C_{IN} = \text{tantalum } 1.0\mu F, C_{OUT} = \text{tantalum } 2.2\mu F$

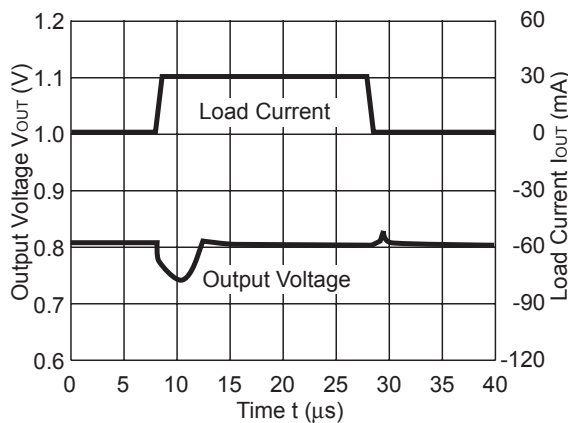

R1161x08xx (ECO=L)

$V_{IN}=1.8V$,
 $C_{IN} = \text{tantalum } 1.0\mu F, C_{OUT} = \text{tantalum } 1.0\mu F$

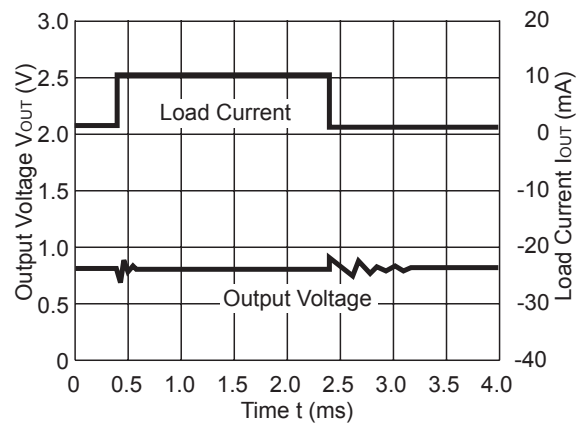

R1161x08xx (ECO=L)

$V_{IN}=1.8V$,
 $C_{IN} = \text{tantalum } 1.0\mu F, C_{OUT} = \text{Tantalum } 2.2\mu F$

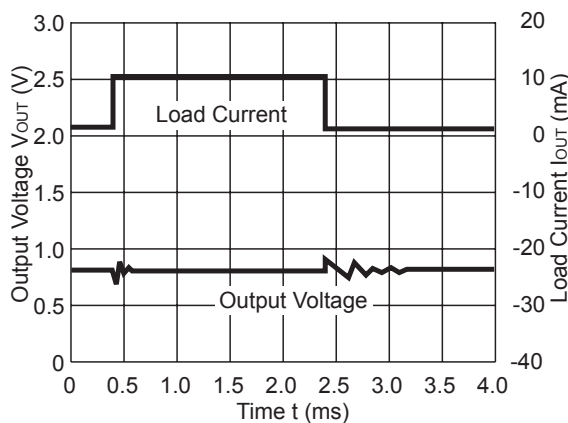

R1161x10xx (ECO=H)

$V_{IN}=2.0V$,
 $C_{IN} = \text{Ceramic } 1.0\mu F, C_{OUT} = \text{Ceramic } 1.0\mu F$

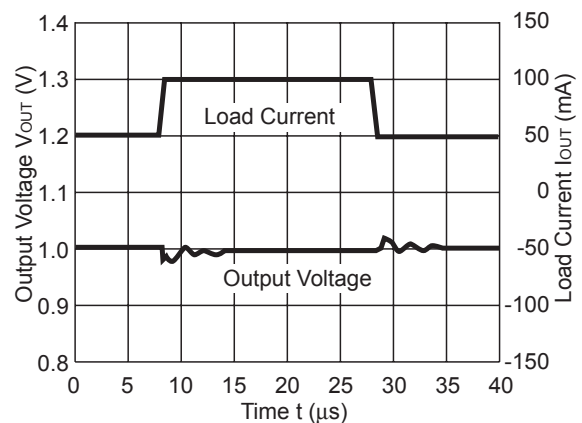

R1161x10xx (ECO=H)

$V_{IN}=2.0V$,
 C_{IN} = Ceramic $1.0\mu F$, C_{OUT} = Ceramic $2.2\mu F$

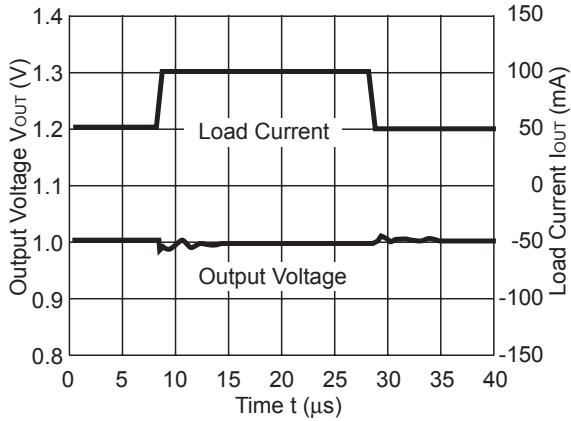

R1161x10xx (ECO=H)

$V_{IN}=2.0V$,
 C_{IN} = Ceramic $1.0\mu F$, C_{OUT} = Ceramic $1.0\mu F$

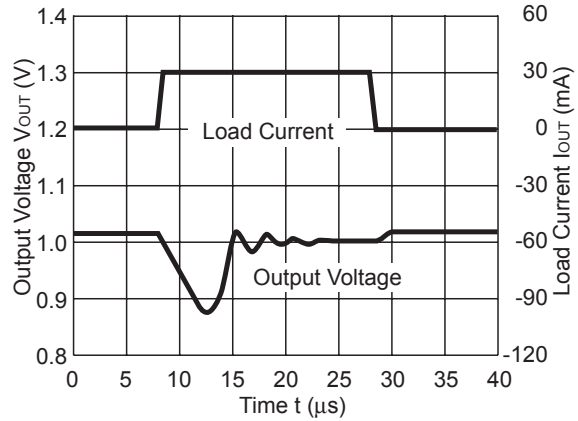

R1161x10xx (ECO=H)

$V_{IN}=2.0V$,
 C_{IN} = Ceramic $1.0\mu F$, C_{OUT} = Ceramic $2.2\mu F$

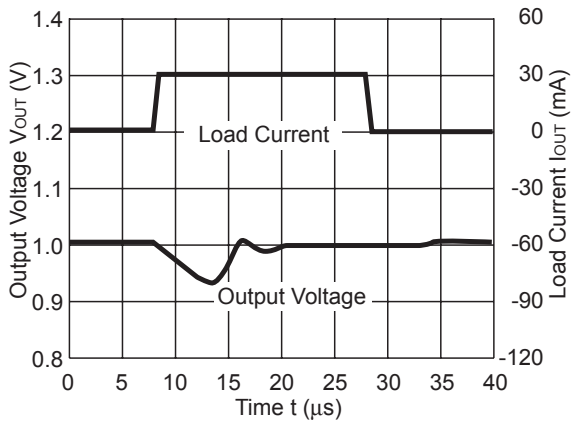

R1161x10xx (ECO=H)

$V_{IN}=2.0V$,
 C_{IN} = Ceramic $1.0\mu F$, C_{OUT} = Ceramic $1.0\mu F$

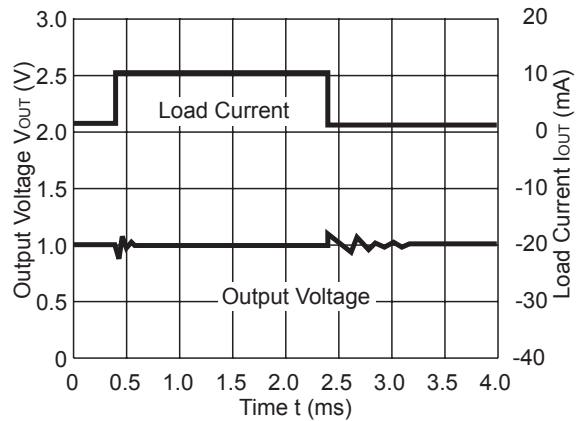

R1161x10xx (ECO=L)

$V_{IN}=2.0V$,
 C_{IN} = Ceramic $1.0\mu F$, C_{OUT} = Ceramic $2.2\mu F$

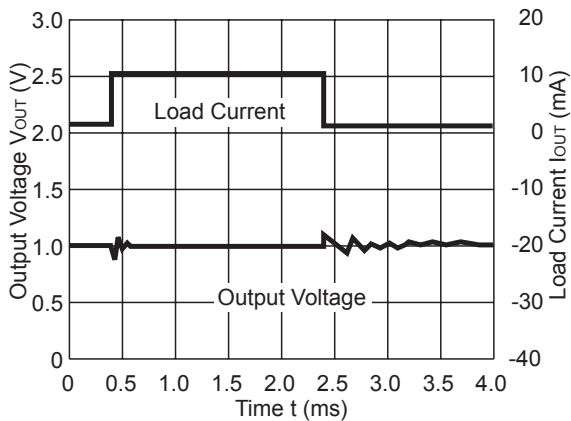

R1161x10xx (ECO=L)

$V_{IN}=2.0V$,
 C_{IN} = Ceramic $1.0\mu F$, C_{OUT} = Ceramic $1.0\mu F$

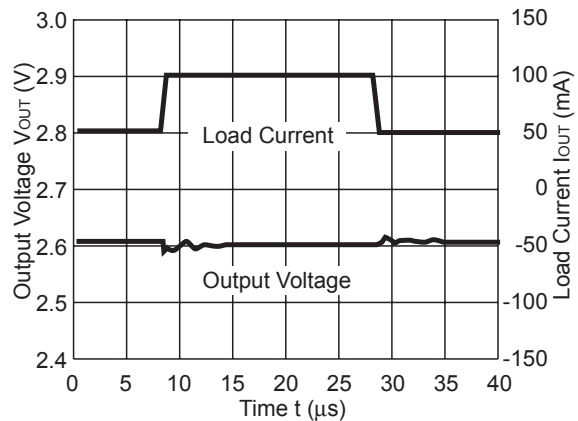

R1161x26xx (ECO=H)

$V_{IN}=3.6V$,
 C_{IN} = Ceramic $1.0\mu F$ C_{OUT} = Ceramic $2.2\mu F$

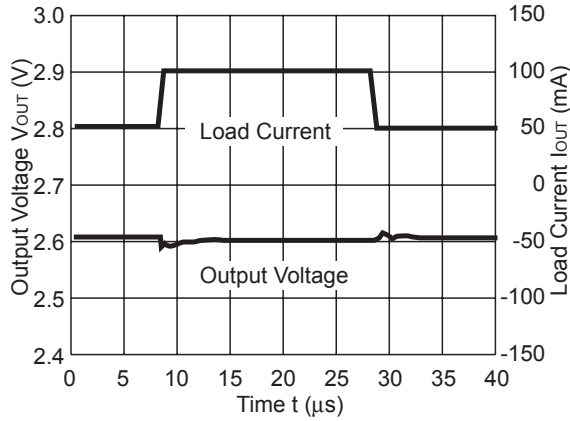

R1161x26xx (ECO=H)

$V_{IN}=3.6V$,
 C_{IN} = Ceramic $1.0\mu F$ C_{OUT} = Ceramic $1.0\mu F$

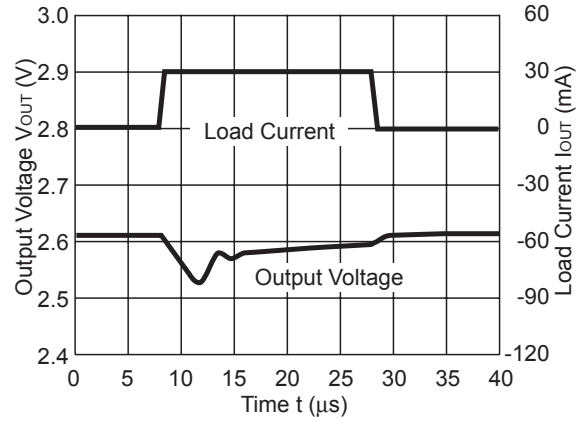

R1161x26xx (ECO=H)

$V_{IN}=3.6V$,
 C_{IN} = Ceramic $1.0\mu F$ C_{OUT} = Ceramic $2.2\mu F$

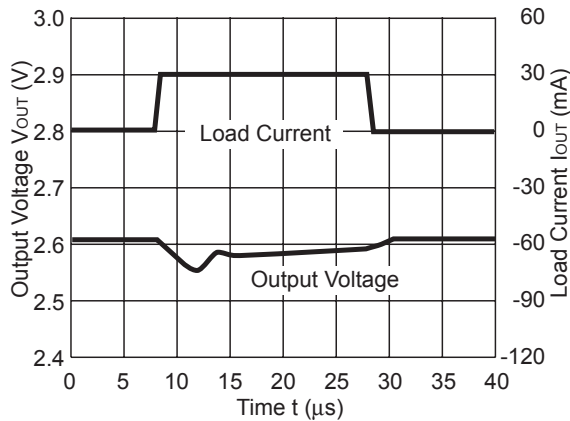

R1161x26xx (ECO=L)

$V_{IN}=3.6V$,
 C_{IN} = Ceramic $1.0\mu F$ C_{OUT} = Ceramic $1.0\mu F$

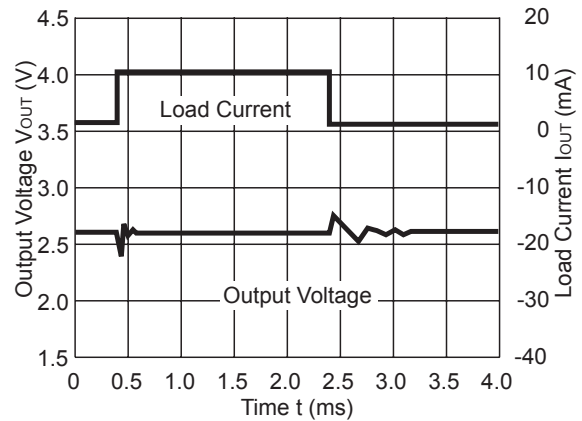

R1161x26xx (ECO=L)

$V_{IN}=3.6V$,
 C_{IN} = Ceramic $1.0\mu F$ C_{OUT} = Ceramic $2.2\mu F$

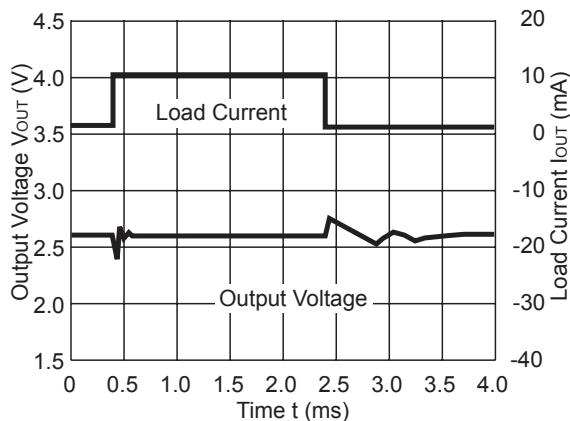

12) Turn on speed with CE pin

R1161x08xx (ECO=H)

V_{IN}=1.8V, C_{IN} = Tantalum 1.0μF
C_{OUT} = Tantalum 1.0μF

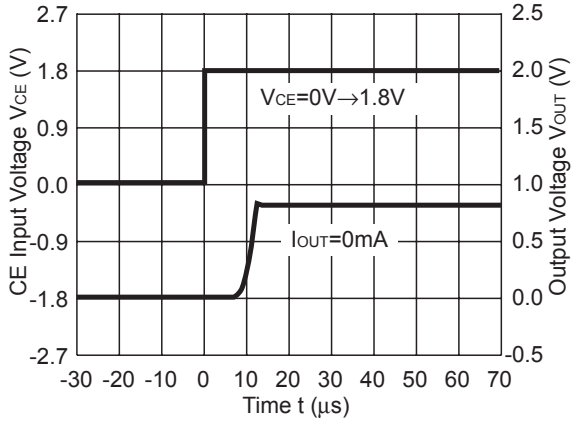

R1161x08xx (ECO=L)

V_{IN}=1.8V, C_{IN} = Tantalum 1.0μF
C_{OUT} = Tantalum 1.0μF

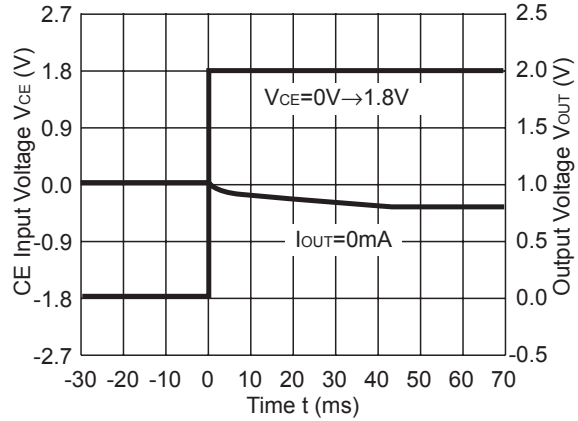

R1161x08xx (ECO=H)

V_{IN}=1.8V, C_{IN} = Tantalum 1.0μF
C_{OUT} = Tantalum 1.0μF

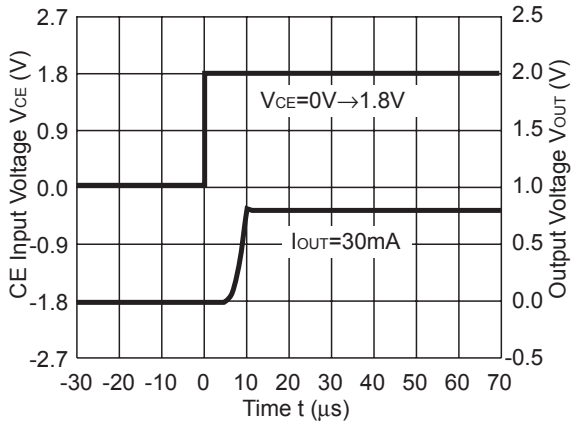

R1161x08xx (ECO=L)

V_{IN}=1.8V, C_{IN} = Tantalum 1.0μF
C_{OUT} = Tantalum 1.0μF

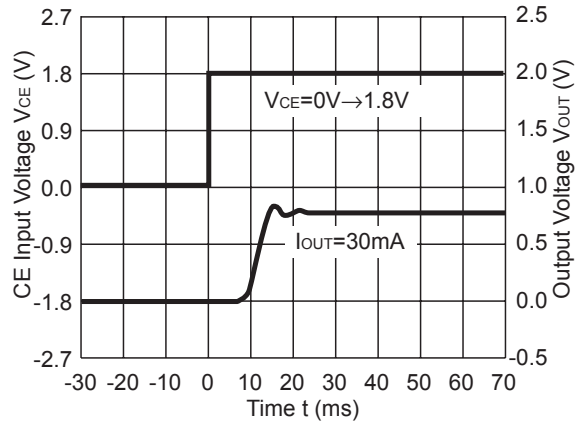

R1161x08xx (ECO=H)

V_{IN}=1.8V, C_{IN} = Tantalum 1.0μF
C_{OUT} = Tantalum 1.0μF

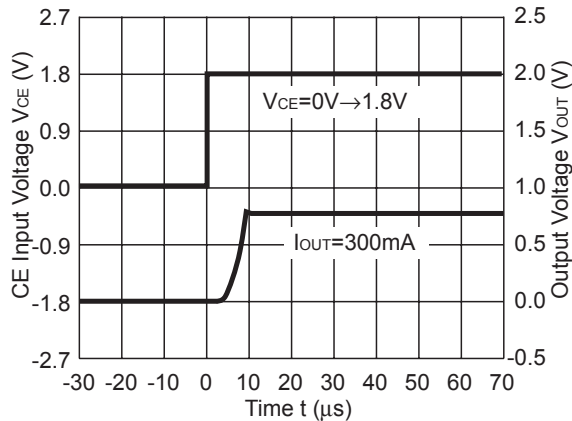

R1161x08xx (ECO=L)

V_{IN}=1.8V, C_{IN} = Tantalum 1.0μF
C_{OUT} = Tantalum 1.0μF

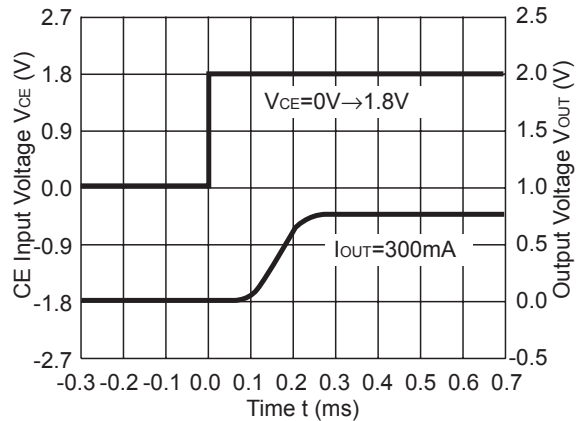

R1161x33xx (ECO=H)

V_{IN}=4.3V, C_{IN} = Ceramic 1.0μF
C_{OUT} = Ceramic 1.0μF

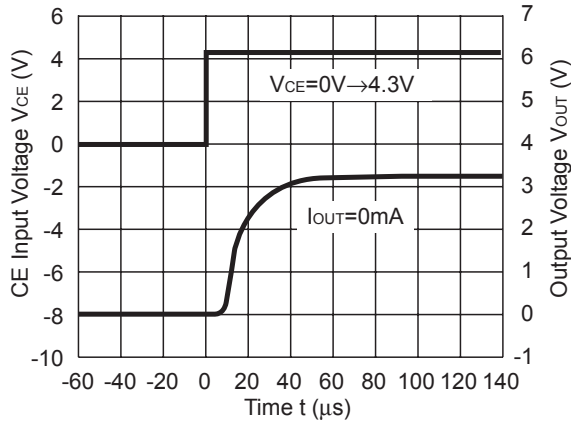

R1161x33xx (ECO=L)

V_{IN}=4.3V, C_{IN} = Ceramic 1.0μF
C_{OUT} = Ceramic 1.0μF

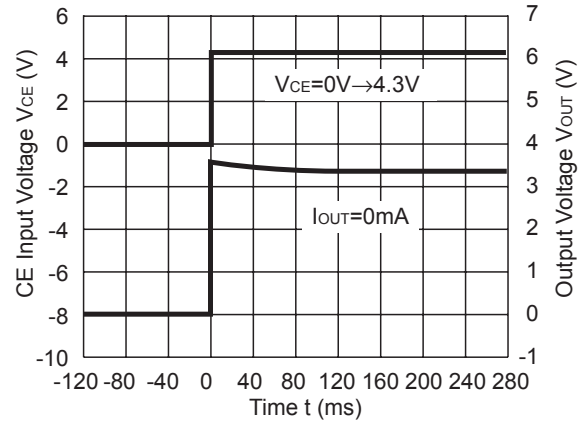

R1161x33xx (ECO=H)

V_{IN}=4.3V, C_{IN} = Ceramic 1.0μF
C_{OUT} = Ceramic 1.0μF

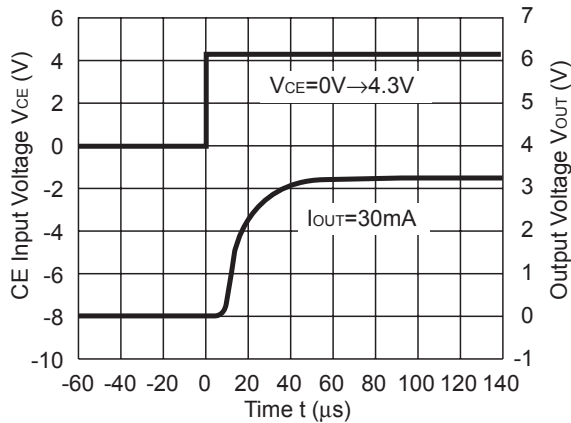

R1161x33xx (ECO=L)

V_{IN}=4.3V, C_{IN} = Ceramic 1.0μF
C_{OUT} = Ceramic 1.0μF

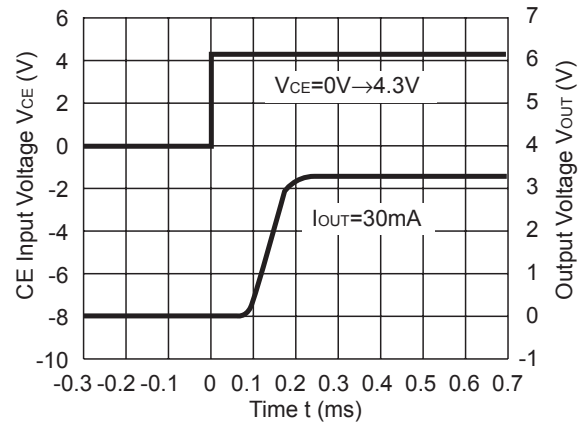

R1161x33xx (ECO=H)

V_{IN}=4.3V, C_{IN} = Ceramic 1.0μF
C_{OUT} = Ceramic 1.0μF

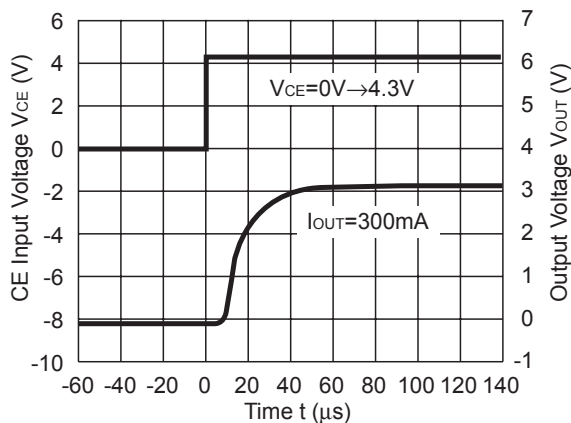

R1161x33xx (ECO=L)

V_{IN}=4.3V, C_{IN} = Ceramic 1.0μF
C_{OUT} = Ceramic 1.0μF

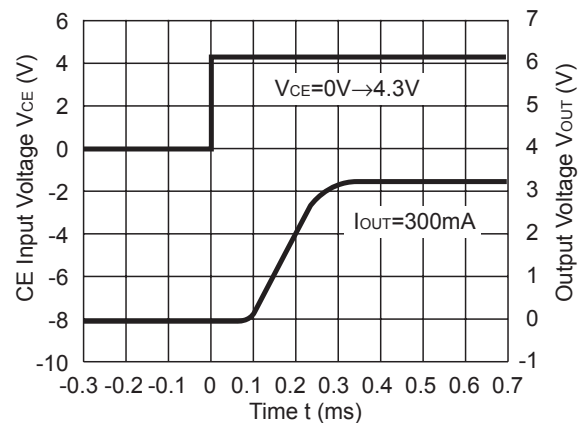

13) Turn-off Speed with CE

R1161x08xD

V_{IN}=1.8V, C_{IN} = Tantalum 1.0μF
C_{OUT} = Tantalum 1.0μF

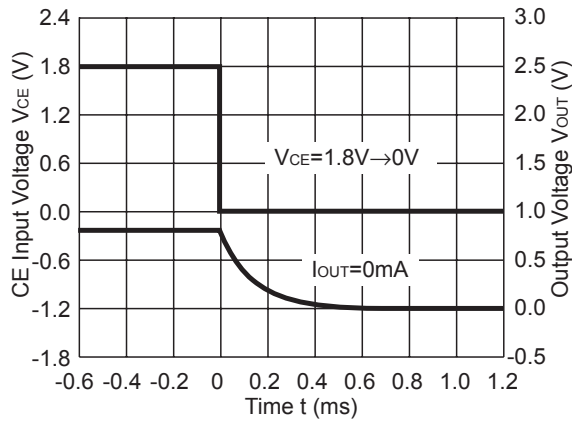

R1161x08xD

V_{IN}=1.8V, C_{IN} = Tantalum 1.0μF
C_{OUT} = Tantalum 1.0μF

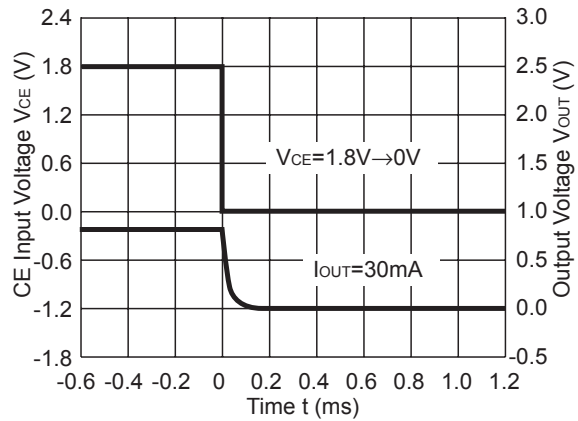

R1161x08xD

V_{IN}=1.8V, C_{IN} = Tantalum 1.0μF
C_{OUT} = Tantalum 1.0μF

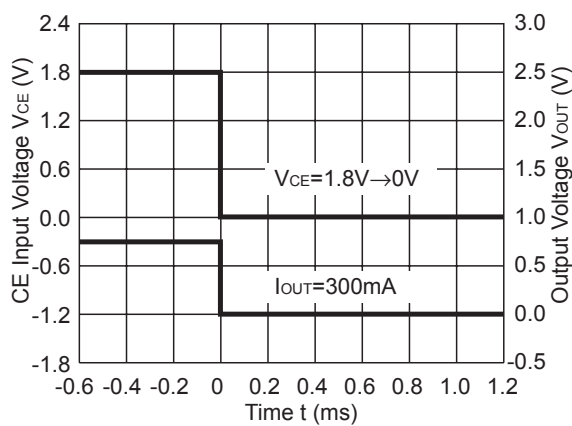

R1161x33xD

V_{IN}=4.3V, C_{IN} = Ceramic 1.0μF
C_{OUT} = Ceramic 1.0μF

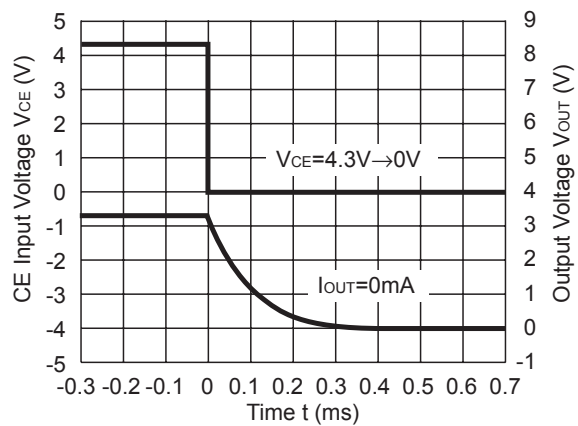

R1161x33xD

V_{IN}=4.3V, C_{IN} = Ceramic 1.0μF
C_{OUT} = Ceramic 1.0μF

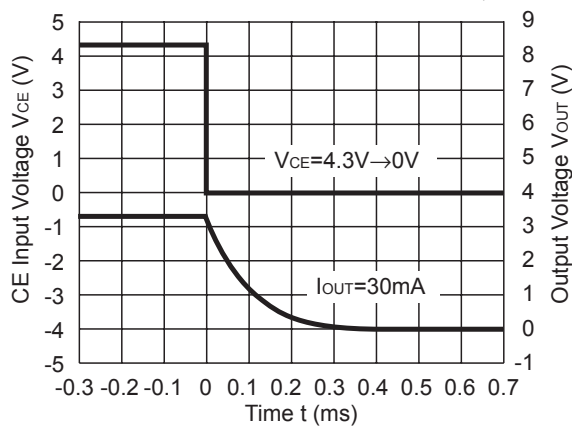

R1161x33xD

V_{IN}=4.3V, C_{IN} = Ceramic 1.0μF
C_{OUT} = Ceramic 1.0μF

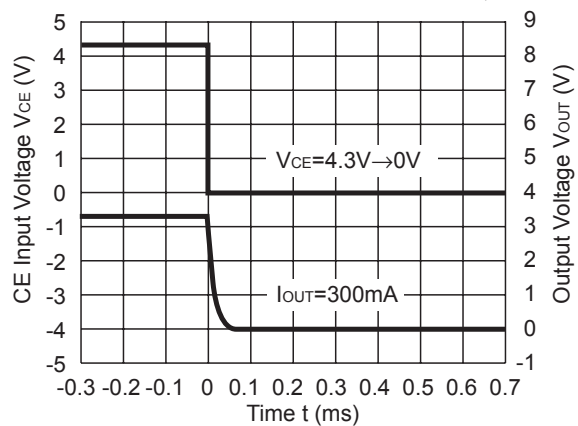

14) Output Voltage at Mode alternative point

R1161x08xx

$V_{IN}=1.8V$, C_{IN} = Ceramic $1.0\mu F$
 C_{OUT} = Tantalum $1.0\mu F$

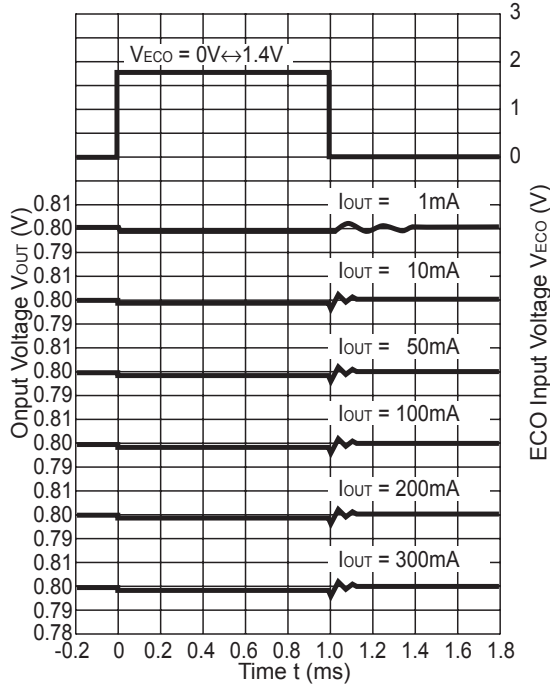

R1161x08xx

$V_{IN}=1.8V$, C_{IN} = Ceramic $1.0\mu F$
 C_{OUT} = Tantalum $1.0\mu F$

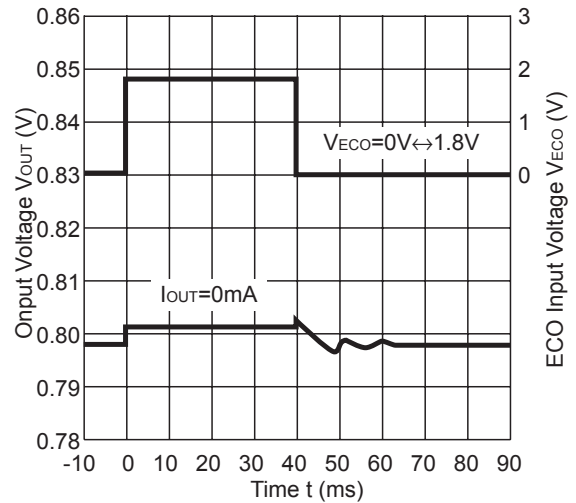

R1161x10xx

$V_{IN}=2.0V$, C_{IN} = Ceramic $1.0\mu F$
 C_{OUT} = Ceramic $1.0\mu F$

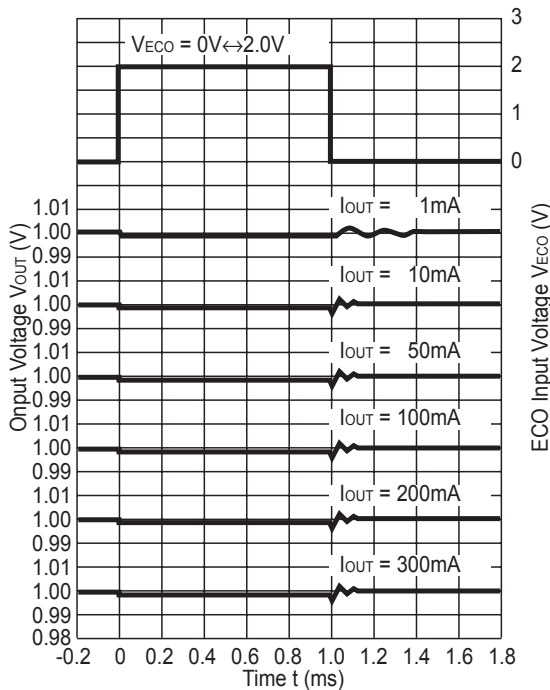

R1161x10xx

$V_{IN}=2.0V$, C_{IN} = Ceramic $1.0\mu F$
 C_{OUT} = Ceramic $1.0\mu F$

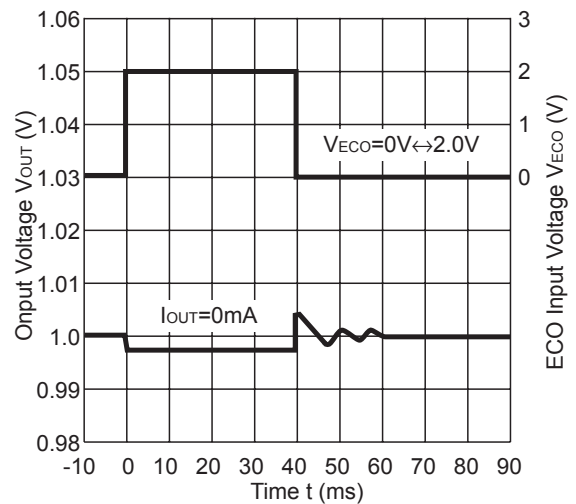

R1161x26xx

V_{IN}=3.6V, C_{IN} = Ceramic 1.0μF
C_{OUT} = Ceramic 1.0μF

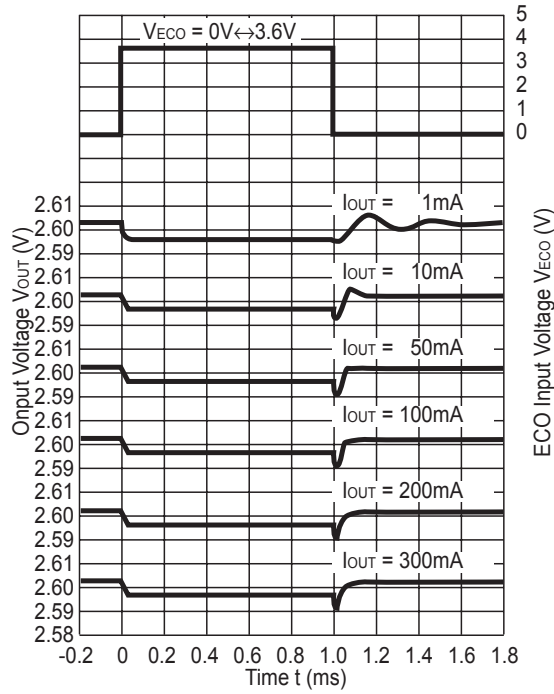

R1161x26xx

V_{IN}=3.6V, C_{IN} = Ceramic 1.0μF
C_{OUT} = Ceramic 1.0μF

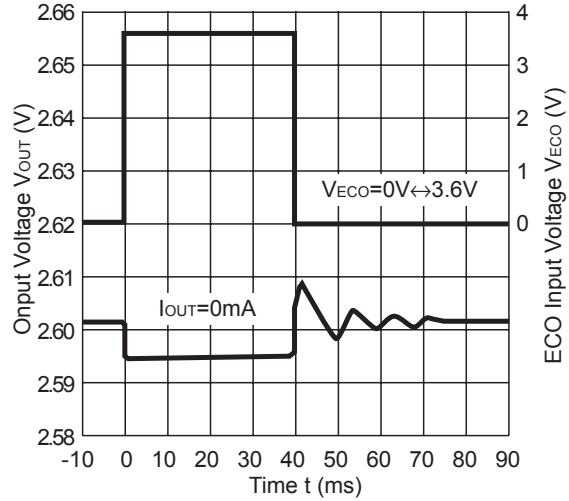

TECHNICAL NOTES

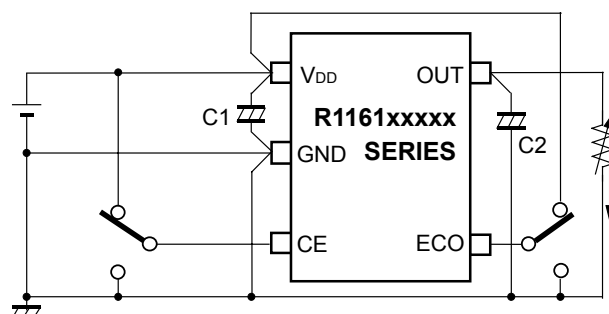

When using these ICs, consider the following points:

1. Mounting on PCB

Make V_{DD} and GND lines sufficient. If their impedance is high, noise pickup or unstable operation may result. Connect a capacitor C1 with as much as $1.0\mu\text{F}$ capacitor between V_{DD} and GND pin as close as possible.

Set external components, especially the output capacitor as close as possible to the ICs and make wiring as short as possible.

2. Phase Compensation

In these ICs, phase compensation is made for securing stable operation even if the load current is varied. For this purpose, be sure to use a $1.0\mu\text{F}$ more capacitor C2 with good frequency characteristics and ESR (Equivalent Series Resistance).

Output Voltage	Recommended Value of C2
$V_{OUT} < 1.0\text{V}$	$1.0\mu\text{F}$ or more Tantalum Capacitor
$1.0\text{V} \leq V_{OUT}$	$1.0\mu\text{F}$ or more Ceramic Capacitor

(Note: When the additional ceramic capacitors are connected to the Output Pin with Output capacitor for phase compensation, the operation might be unstable. Because of this, test these ICs with as same external components as ones to be used on the PCB.)

If you use a tantalum type capacitor and ESR value of the capacitor is large, output might be unstable. Evaluate your circuit with considering frequency characteristics.

Depending on the capacitor size, manufacturer, and part number, the bias characteristics and temperature characteristics are different. Evaluate the circuit with actual using capacitors.

ESR vs. Output Current

When using these ICs, consider the following points:

In these ICs, phase compensation is made for securing stable operation even if the output current is varied. For this purpose, be sure to use a capacitor C_{OUT} with good frequency characteristics and ESR (Equivalent Series Resistance) in the range described as follows:

The relations between I_{OUT} (Output Current) and ESR of Output Capacitor are shown below.

The conditions when the white noise level is under $40\mu\text{V}$ (Avg.) are marked as the hatched area in the graph.

<Test conditions>

- (1) Frequency band: 10Hz to 2MHz
- (2) Temperature: 25°C

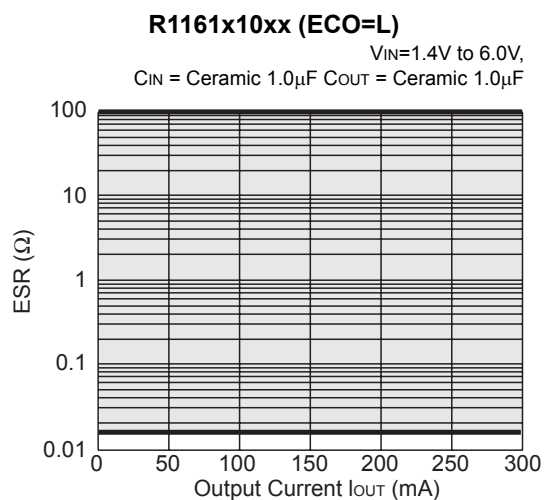
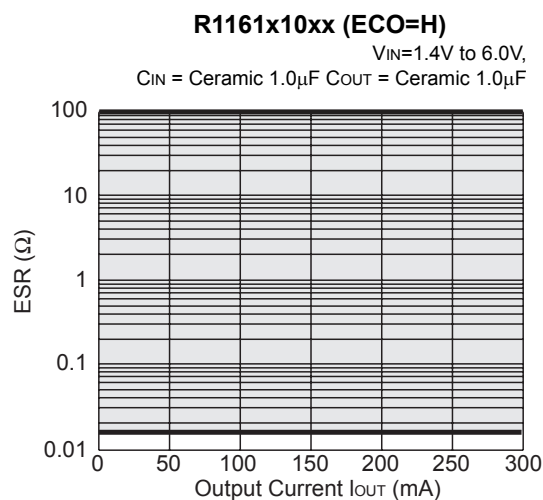
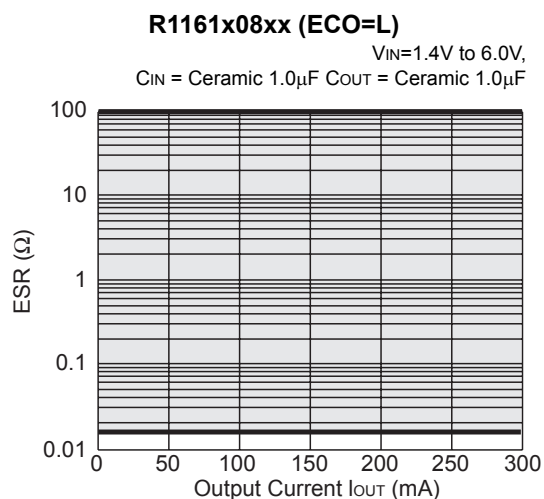
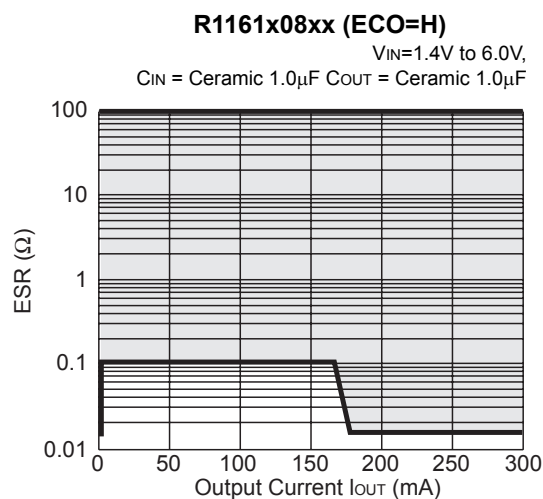

R1161x26xx (ECO=H)

$V_{IN}=3.0V$ to $6.0V$,
 C_{IN} = Ceramic $1.0\mu F$ C_{OUT} = Ceramic $1.0\mu F$

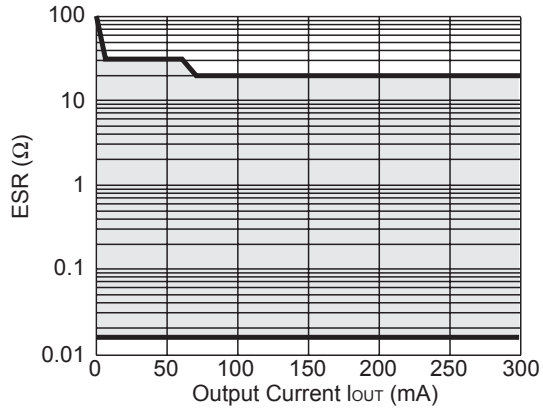

R1161x26xx (ECO=L)

$V_{IN}=3.0V$ to $6.0V$,
 C_{IN} = Ceramic $1.0\mu F$ C_{OUT} = Ceramic $1.0\mu F$

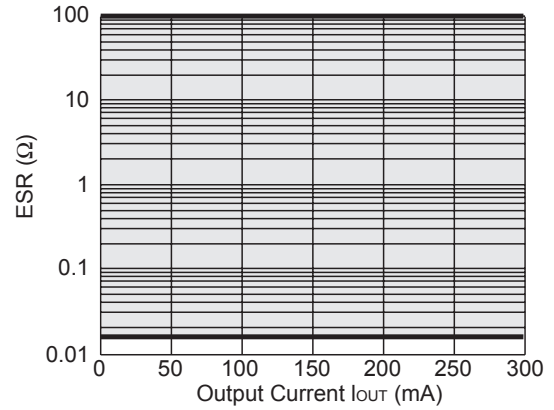

R1161x15xx (ECO=H)

$V_{IN}=2.0V$ to $6.0V$,
 C_{IN} = Ceramic $1.0\mu F$ C_{OUT} = Ceramic $1.0\mu F$

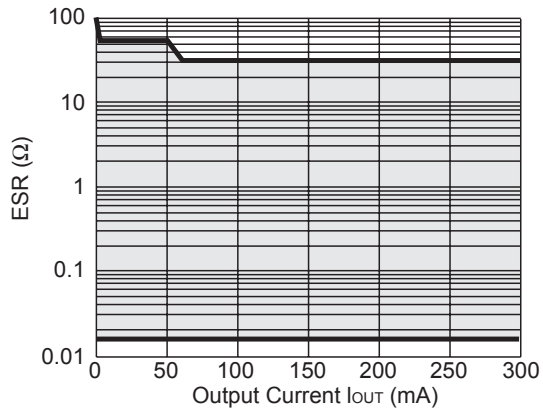

R1161x30xx (ECO=H)

$V_{IN}=3.6V$ to $6.0V$,
 C_{IN} = Ceramic $1.0\mu F$ C_{OUT} = Ceramic $1.0\mu F$

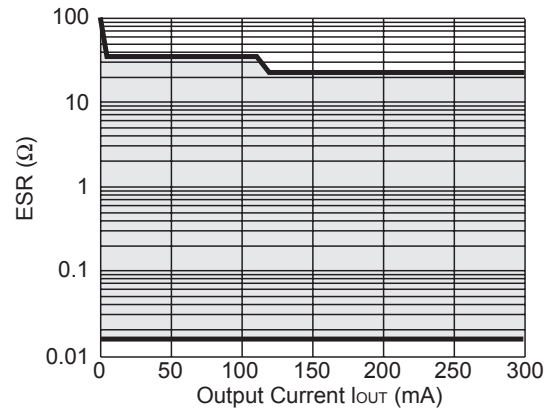

- SOT-23-5 (SC-74A)

Unit: mm

PACKAGE DIMENSIONS

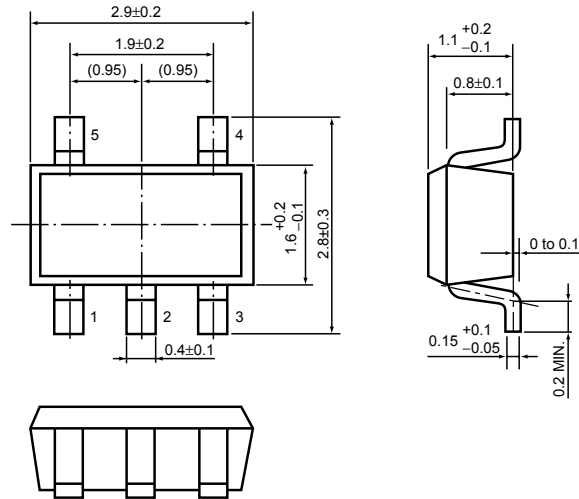

TAPING SPECIFICATION

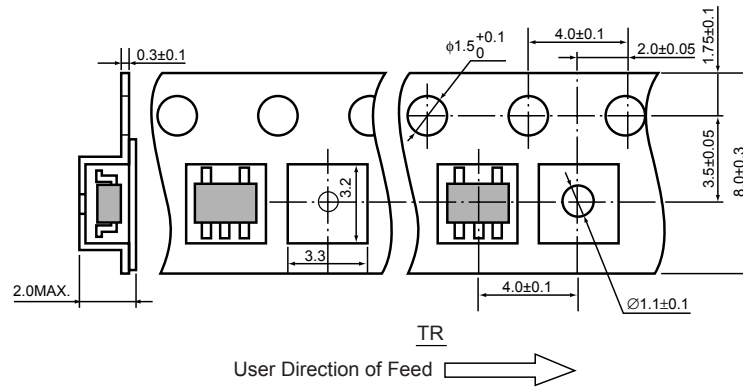

TAPING REEL DIMENSIONS

(1reel=3000pcs)

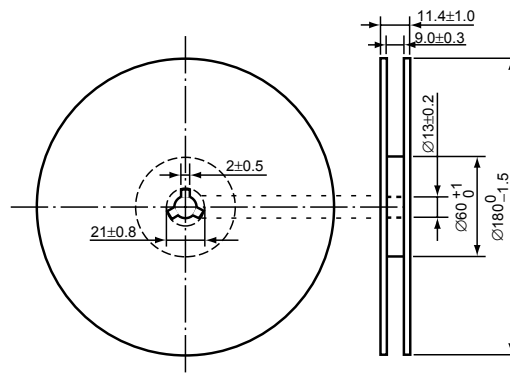

POWER DISSIPATION (SOT-23-5)

This specification is at mounted on board. Power Dissipation (P_D) depends on conditions of mounting on board. This specification is based on the measurement at the condition below: (Power Dissipation (SOT-23-5) is substitution of SOT-23-6.)

Measurement Conditions

	Standard Land Pattern
Environment	Mounting on Board (Wind velocity=0m/s)
Board Material	Glass cloth epoxy plactic (Double sided)
Board Dimensions	40mm × 40mm × 1.6mm
Copper Ratio	Top side : Approx. 50% , Back side : Approx. 50%
Through-hole	φ0.5mm × 44pcs

Measurement Result

($T_{opt}=25^{\circ}C, T_{jmax}=125^{\circ}C$)

	Standard Land Pattern	Free Air
Power Dissipation	420mW	250mW
Thermal Resistance	$\theta_{ja}=(125-25^{\circ}C)/0.42W=263^{\circ}C/W$	400 $^{\circ}C/W$

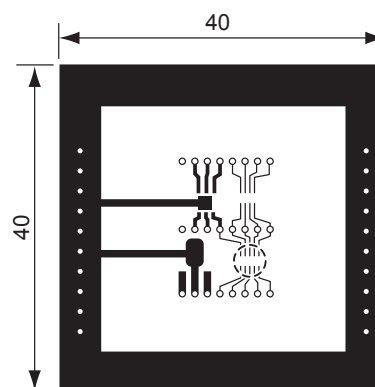
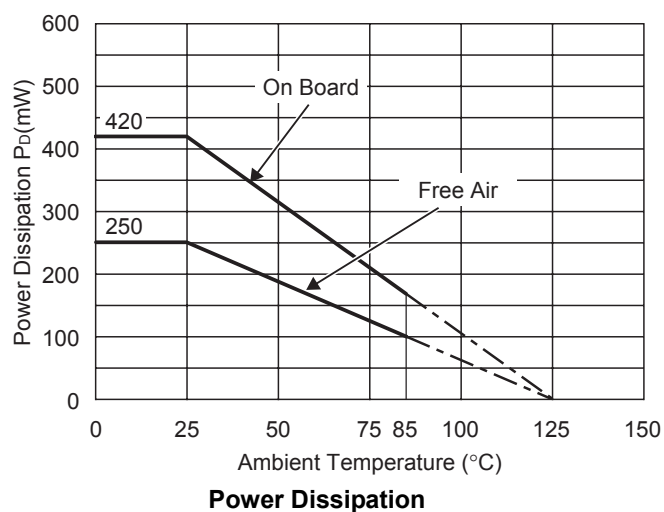

Measurement Board Pattern

○ IC Mount Area Unit : mm

RECOMMENDED LAND PATTERN

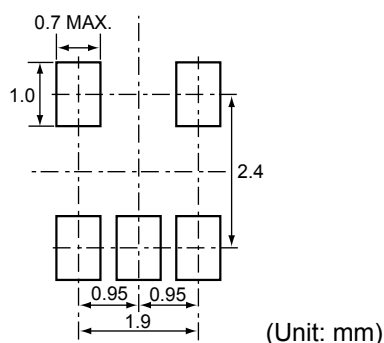

• SON-6

Unit: mm

PACKAGE DIMENSIONS

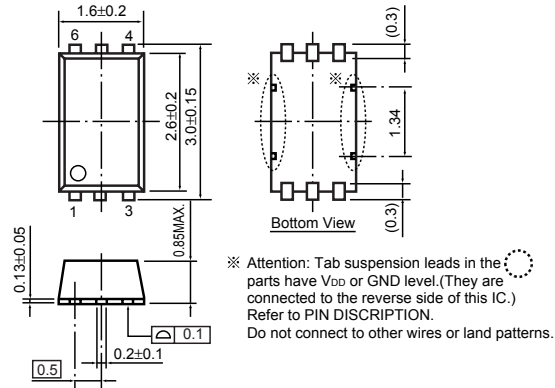

TAPING SPECIFICATION

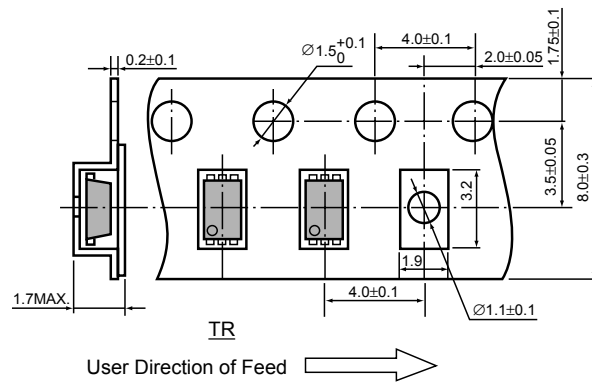

TAPING REEL DIMENSIONS

(1reel=3000pcs)

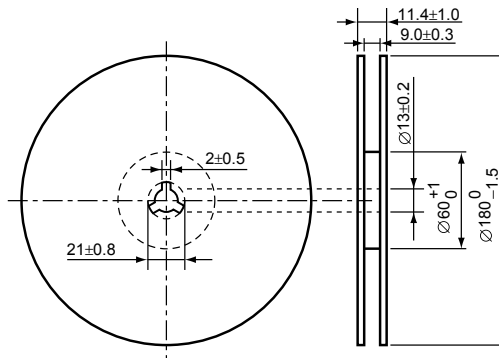

POWER DISSIPATION (SON-6)

This specification is at mounted on board. Power Dissipation (P_D) depends on conditions of mounting on board. This specification is based on the measurement at the condition below:

Measurement Conditions

	Standard Land Pattern
Environment	Mounting on Board (Wind velocity=0m/s)
Board Material	Glass cloth epoxy plactic (Double sided)
Board Dimensions	40mm × 40mm × 1.6mm
Copper Ratio	Top side : Approx. 50% , Back side : Approx. 50%
Through-hole	φ0.5mm × 44pcs

Measurement Result

($T_{opt}=25^{\circ}C, T_{jmax}=125^{\circ}C$)

	Standard Land Pattern	Free Air
Power Dissipation	500mW	250mW
Thermal Resistance	$\theta_{ja}=(125-25^{\circ}C)/0.5W=200^{\circ}C/W$	-

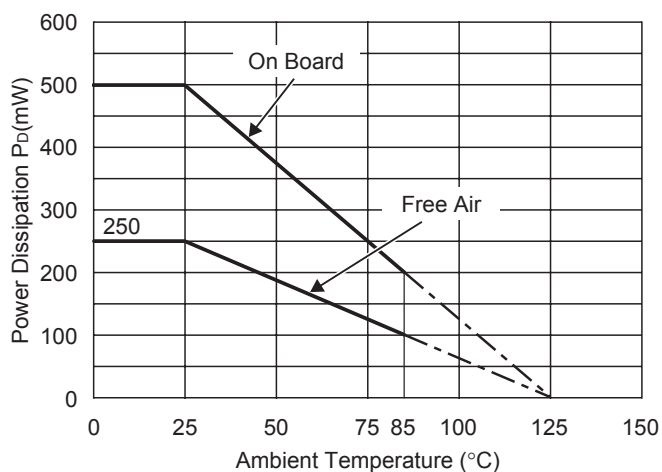

Power Dissipation

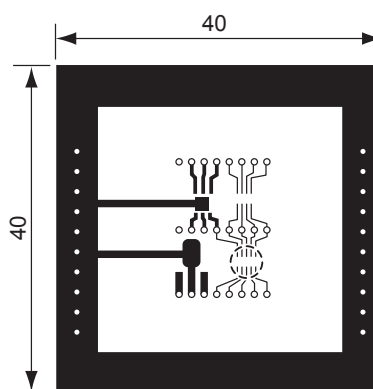

Measurement Board Pattern

○ IC Mount Area (Unit : mm)

RECOMMENDED LAND PATTERN

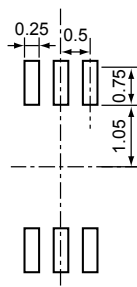

(Unit: mm)

• HSON-6

Unit: mm

PACKAGE DIMENSIONS

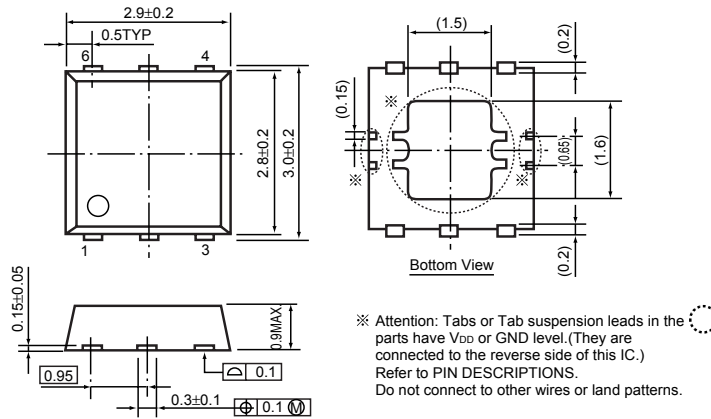

TAPING SPECIFICATION

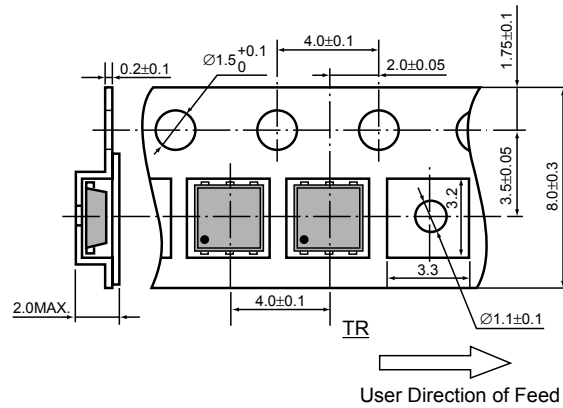

TAPING REEL DIMENSIONS

(1reel=3000pcs)

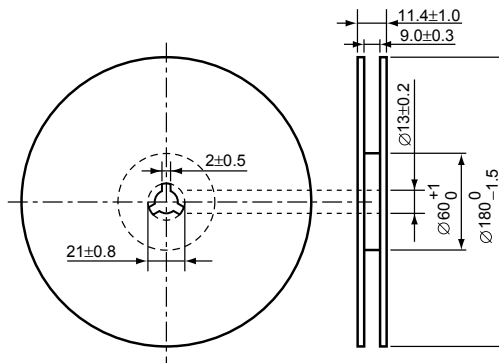

POWER DISSIPATION (HSON-6)

This specification is at mounted on board. Power Dissipation (P_D) depends on conditions of mounting on board. This specification is based on the measurement at the condition below:

Measurement Conditions

	Standard Land Pattern
Environment	Mounting on Board (Wind velocity=0m/s)
Board Material	Glass cloth epoxy plactic (Double sided)
Board Dimensions	40mm × 40mm × 1.6mm
Copper Ratio	Top side : Approx. 50% , Back side : Approx. 50%
Through-hole	φ0.5mm × 44pcs

Measurement Result

($T_{opt}=25^{\circ}C, T_{jmax}=125^{\circ}C$)

	Standard Land Pattern	Free Air
Power Dissipation	900mW	400mW
Thermal Resistance	$\theta_{ja}=(125-25^{\circ}C)/0.9W=111^{\circ}C/W$	250 $^{\circ}C/W$

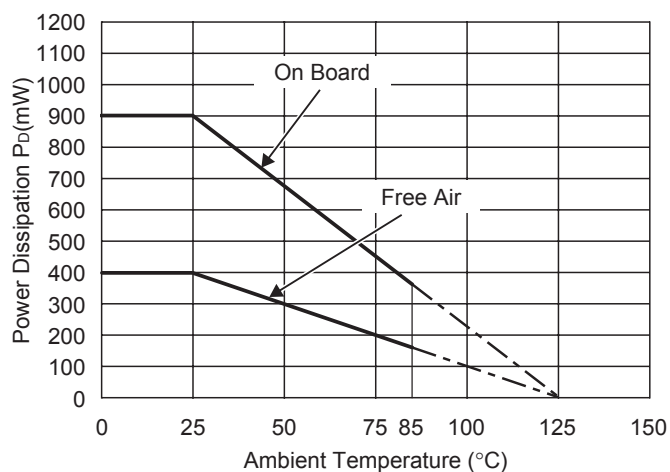

Power Dissipation

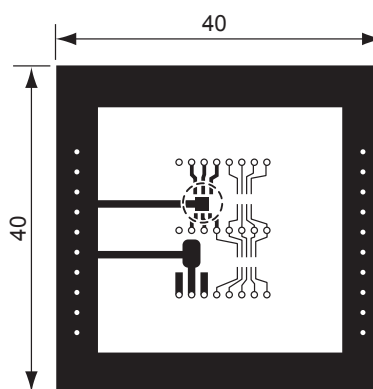

Measurement Board Pattern

○ IC Mount Area Unit : mm

RECOMMENDED LAND PATTERN

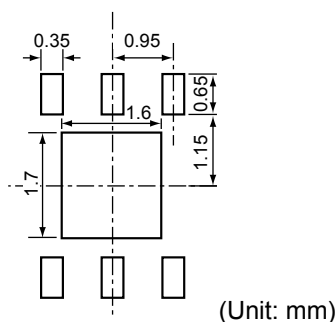

(Unit: mm)

R1161N SERIES MARK SPECIFICATION

● SOT-23-5 (SC-74A)

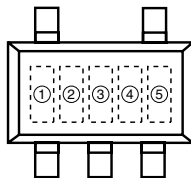

①, ②, ③ : Product Code (refer to Part Number vs. Product Code)

④, ⑤ : Lot Number

● Part Number vs. Product Code

Part Number	Product Code		
	①	②	③
R1161N081A	P	0	8
R1161N091A	P	0	9
R1161N101A	P	1	0
R1161N111A	P	1	1
R1161N121A	P	1	2
R1161N131A	P	1	3
R1161N141A	P	1	4
R1161N151A	P	1	5
R1161N161A	P	1	6
R1161N171A	P	1	7
R1161N181A	P	1	8
R1161N191A	P	1	9
R1161N201A	P	2	0
R1161N211A	P	2	1
R1161N221A	P	2	2
R1161N231A	P	2	3
R1161N241A	P	2	4
R1161N251A	P	2	5
R1161N261A	P	2	6
R1161N271A	P	2	7
R1161N281A	P	2	8
R1161N291A	P	2	9
R1161N301A	P	3	0
R1161N311A	P	3	1
R1161N321A	P	3	2
R1161N331A	P	3	3
R1161N281A5	P	0	0

Part Number	Product Code		
	①	②	③
R1161N081B	Q	0	8
R1161N091B	Q	0	9
R1161N101B	Q	1	0
R1161N111B	Q	1	1
R1161N121B	Q	1	2
R1161N131B	Q	1	3
R1161N141B	Q	1	4
R1161N151B	Q	1	5
R1161N161B	Q	1	6
R1161N171B	Q	1	7
R1161N181B	Q	1	8
R1161N191B	Q	1	9
R1161N201B	Q	2	0
R1161N211B	Q	2	1
R1161N221B	Q	2	2
R1161N231B	Q	2	3
R1161N241B	Q	2	4
R1161N251B	Q	2	5
R1161N261B	Q	2	6
R1161N271B	Q	2	7
R1161N281B	Q	2	8
R1161N291B	Q	2	9
R1161N301B	Q	3	0
R1161N311B	Q	3	1
R1161N321B	Q	3	2
R1161N331B	Q	3	3
R1161N281B5	Q	0	0

Part Number	Product Code		
	①	②	③
R1161N081D	R	0	8
R1161N091D	R	0	9
R1161N101D	R	1	0
R1161N111D	R	1	1
R1161N121D	R	1	2
R1161N131D	R	1	3
R1161N141D	R	1	4
R1161N151D	R	1	5
R1161N161D	R	1	6
R1161N171D	R	1	7
R1161N181D	R	1	8
R1161N191D	R	1	9
R1161N201D	R	2	0
R1161N211D	R	2	1
R1161N221D	R	2	2
R1161N231D	R	2	3
R1161N241D	R	2	4
R1161N251D	R	2	5
R1161N261D	R	2	6
R1161N271D	R	2	7
R1161N281D	R	2	8
R1161N291D	R	2	9
R1161N301D	R	3	0
R1161N311D	R	3	1
R1161N321D	R	3	2
R1161N331D	R	3	3
R1161N281D5	R	0	0

R1161Dxx1 SERIES MARK SPECIFICATION

● SON-6

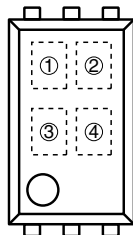

①, ② : Product Code (refer to Part Number vs. Product Code)

③, ④ : Lot Number

● Part Number vs. Product Code

Part Number	Product Code	
	①	②
R1161D081A	8	A
R1161D091A	9	A
R1161D101A	0	B
R1161D111A	1	B
R1161D121A	2	B
R1161D131A	3	B
R1161D141A	4	B
R1161D151A	5	B
R1161D161A	6	B
R1161D171A	7	B
R1161D181A	8	B
R1161D191A	9	B
R1161D201A	0	C
R1161D211A	1	C
R1161D221A	2	C
R1161D231A	3	C
R1161D241A	4	C
R1161D251A	5	C
R1161D261A	6	C
R1161D271A	7	C
R1161D281A	8	C
R1161D291A	9	C
R1161D301A	0	D
R1161D311A	1	D
R1161D321A	2	D
R1161D331A	3	D
R1161D281A5	0	A
R1161D121A5	1	A
R1161D181A5	2	A

Part Number	Product Code	
	①	②
R1161D081B	8	E
R1161D091B	9	E
R1161D101B	0	F
R1161D111B	1	F
R1161D121B	2	F
R1161D131B	3	F
R1161D141B	4	F
R1161D151B	5	F
R1161D161B	6	F
R1161D171B	7	F
R1161D181B	8	F
R1161D191B	9	F
R1161D201B	0	G
R1161D211B	1	G
R1161D221B	2	G
R1161D231B	3	G
R1161D241B	4	G
R1161D251B	5	G
R1161D261B	6	G
R1161D271B	7	G
R1161D281B	8	G
R1161D291B	9	G
R1161D301B	0	H
R1161D311B	1	H
R1161D321B	2	H
R1161D331B	3	H
R1161D281B	0	E
R1161D121B5	1	E
R1161D181B5	2	E

Part Number	Product Code	
	①	②
R1161D081D	8	J
R1161D091D	9	J
R1161D101D	0	J
R1161D111D	1	K
R1161D121D	2	K
R1161D131D	3	K
R1161D141D	4	K
R1161D151D	5	K
R1161D161D	6	K
R1161D171D	7	K
R1161D181D	8	K
R1161D191D	9	K
R1161D201D	0	L
R1161D211D	1	L
R1161D221D	2	L
R1161D231D	3	L
R1161D241D	4	L
R1161D251D	5	L
R1161D261D	6	L
R1161D271D	7	L
R1161D281D	8	L
R1161D291D	9	L
R1161D301D	0	M
R1161D311D	1	M
R1161D321D	2	M
R1161D331D	3	M
R1161D281D	0	J
R1161D121D5	1	J
R1161D181D5	2	J

R1161Dxx2 SERIES MARK SPECIFICATION

● HSON-6

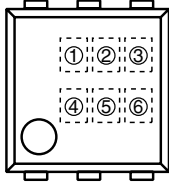

- ① : B (fixed)
- ②, ③ : Setting Voltage } (refer to Part Number vs. Product Code)
- ④ : Type (A, B,D)
- ⑤, ⑥ : Lot Number

● Part Number vs. Product Code

Part Number	Product Code			
	①	②	③	④
R1161D082A	B	0	8	A
R1161D092A	B	0	9	A
R1161D102A	B	1	0	A
R1161D112A	B	1	1	A
R1161D122A	B	1	2	A
R1161D132A	B	1	3	A
R1161D142A	B	1	4	A
R1161D152A	B	1	5	A
R1161D162A	B	1	6	A
R1161D172A	B	1	7	A
R1161D182A	B	1	8	A
R1161D192A	B	1	9	A
R1161D202A	B	2	0	A
R1161D212A	B	2	1	A
R1161D222A	B	2	2	A
R1161D232A	B	2	3	A
R1161D242A	B	2	4	A
R1161D252A	B	2	5	A
R1161D262A	B	2	6	A
R1161D272A	B	2	7	A
R1161D282A	B	2	8	A
R1161D292A	B	2	9	A
R1161D302A	B	3	0	A
R1161D312A	B	3	1	A
R1161D322A	B	3	2	A
R1161D332A	B	3	3	A
R1161D282A5	B	0	0	A
R1161D122A5	B	0	1	A
R1161D182A5	B	0	2	A

Part Number	Product Code			
	①	②	③	④
R1161D082B	B	0	8	B
R1161D092B	B	0	9	B
R1161D102B	B	1	0	B
R1161D112B	B	1	1	B
R1161D122B	B	1	2	B
R1161D132B	B	1	3	B
R1161D142B	B	1	4	B
R1161D152B	B	1	5	B
R1161D162B	B	1	6	B
R1161D172B	B	1	7	B
R1161D182B	B	1	8	B
R1161D192B	B	1	9	B
R1161D202B	B	2	0	B
R1161D212B	B	2	1	B
R1161D222B	B	2	2	B
R1161D232B	B	2	3	B
R1161D242B	B	2	4	B
R1161D252B	B	2	5	B
R1161D262B	B	2	6	B
R1161D272B	B	2	7	B
R1161D282B	B	2	8	B
R1161D292B	B	2	9	B
R1161D302B	B	3	0	B
R1161D312B	B	3	1	B
R1161D322B	B	3	2	B
R1161D332B	B	3	3	B
R1161D282B5	B	0	0	B
R1161D122B5	B	0	1	B
R1161D182B5	B	0	2	B

Part Number	Product Code			
	①	②	③	④
R1161D082D	B	0	8	D
R1161D092D	B	0	9	D
R1161D102D	B	1	0	D
R1161D112D	B	1	1	D
R1161D122D	B	1	2	D
R1161D132D	B	1	3	D
R1161D142D	B	1	4	D
R1161D152D	B	1	5	D
R1161D162D	B	1	6	D
R1161D172D	B	1	7	D
R1161D182D	B	1	8	D
R1161D192D	B	1	9	D
R1161D202D	B	2	0	D
R1161D212D	B	2	1	D
R1161D222D	B	2	2	D
R1161D232D	B	2	3	D
R1161D242D	B	2	4	D
R1161D252D	B	2	5	D
R1161D262D	B	2	6	D
R1161D272D	B	2	7	D
R1161D282D	B	2	8	D
R1161D292D	B	2	9	D
R1161D302D	B	3	0	D
R1161D312D	B	3	1	D
R1161D322D	B	3	2	D
R1161D332D	B	3	3	D
R1161D282D5	B	0	0	D
R1161D122D5	B	0	1	D
R1161D182D5	B	0	2	D