

REVISIONS			
ISS	ZONE	DESCRIPTION\PER REQUEST\DATE	

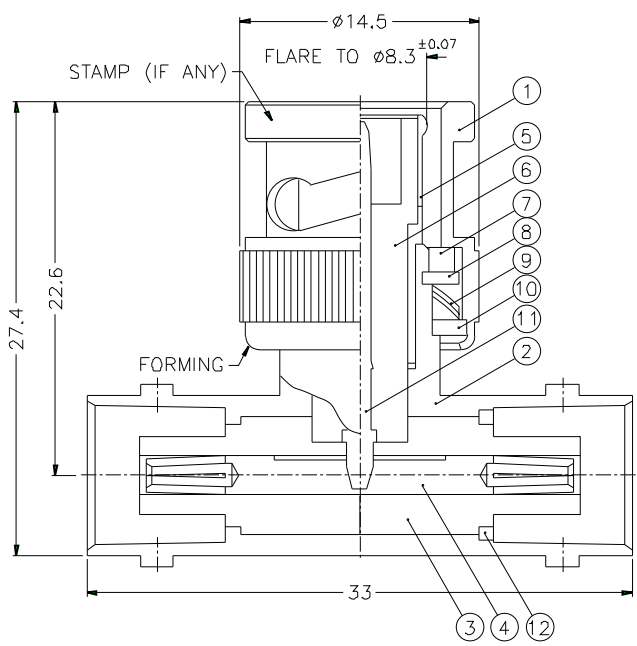

NOTES: FINISH (PLATING THICKNESS IN MICRO-INCHES)

- BRASS PER QQ-B-626
- BRASS PER QQ-B-613
- NICKEL PL. 100 MIN. THICK OVER COPPER STRIKE
- PHOSPHOR BRONZE PER QQ-B-750
- NICKEL PL. 200 MIN. THICK OVER COPPER STRIKE
- NICKEL PL. 100 MIN. THICK OVER COPPER PL. 300 MIN. THICK
- GOLD PL. 3 MIN. THICK OVER NICKEL PL. 100 MIN. THICK OVER COPPER STRIKE
- ZINC DIECAST

12	LOCK RING	NOTE 1	NOTE 3	1	LR-79/62X08
11	CONTACT PIN	NOTE 1	NOTE 7	1	B9073D1-11-B
10	WASHER	NOTE 2	NOTE 3	1	WS-128/9X08
9	SPRING	SK5	NOTE 5	2	B50000-6
8	RETAINER RING	NOTE 1	NOTE 3	1	B50000-5
7	GASKET	RUBBER	RED	1	GS-115/8X15
6	INSULATOR	DELTRIN	NATURAL	1	B9073D1-6-50-B
5	BODY	NOTE 1	NOTE 3	1	B9073D1-5
4	CONTACT PIN	NOTE 4	NOTE 7	1	B9073D1-4-A
3	INSULATOR	DELTRIN	NATURAL	2	B9073D1-3-50-A
2	HOUSING	NOTE 8	NOTE 6	1	B9073D1-2
1	SHELL	NOTE 8	NOTE 6	1	B50000Z-1

DIMENSIONS ARE IN MILLIMETERS
UNLESS OTHERWISE SPECIFIED
TOLERANCES

0.5-6	= ±0.2
6-30	= ±0.4
30-120	= ±0.6
120-315	= ±1
315-1000	= ±1.6
1000-2000	= ±2.4

PART NO.	B9073D1-ND3G-50
APPROVED	DATE 10-11-01'
CHECKED	DATE 10-11-01'
DRAWN	DATE 10-11-01'

Amphenol	
TITLE	BNC "T" ADAPTOR JACK-PLUG-JACK
DRAWING NO.	KJ-B9073D1-ND3G-50
ITEM NO.	

NO.	DESCRIPTION	MATERIAL	FINISH	Q'TY	DRAWING NO.	SCALE	3/1	ISSUE	A	FILE NO.
1										
2										
3										
4										
5										
6										
7										
8										