



Automotive small-signal discretes solutions

Drive the future with our innovative portfolio

PHILIPS

Automotive



Simplifying design through increased functionality

By delivering more functionality from individual products, we help to cut development times. With just a few small-signal discretes several circuit blocks can be built and therewith the number of different components on the bill-of-materials can be reduced significantly.

Our small-signal discretes portfolio offers power and performance levels previously only associated with much larger packages allowing you to replace medium-power products with more compact alternatives. And because you can now get high-performance transistors and diodes in low-cost small-signal packages, you can significantly cut costs. Whether it's superior ESD protection or loadswitch functionality integrated into a single component, our portfolio makes it easier to design a new system.

small-signal discretes solutions



As automotive manufacturers strive to enhance safety, performance, comfort and fuel-efficiency levels, the semiconductor content of vehicles is rising and electronic systems are becoming more complex. Consequently, system suppliers must meet increasingly severe requirements. Building on our expertise in both automotive and small-signal discretes solutions, Philips offers an extensive portfolio of discrete components that help suppliers meet the rigorous and diverse technical demands on automotive electronics. The wide portfolio enables automotive designers to be flexible in their designs. By means of integrated products the component count is decreased and thus costs can be reduced.

All our new products are released in the well-known SOT23 package, as well as in smaller packages like SOT323 (SC-70), SOD323 (SC-76) and SOD323F (SC-90). To support the trend towards integration also multiple transistors and diodes are available integrated into just a single package like SOT457 (SC-74) and SOT363 (SC-88).

Philips has all the technologies in place to lead the way in small-signal discretes products, allowing to develop automotive applications that will drive the future.

Key families

- Low V_{CEsat} (BISS) transistors
- Resistor-equipped transistors (RETs)
- Complex discretes
 - BISS Loadswitches
 - Matched pair transistors
 - MOSFET drivers
- Low V_F (MEGA) Schottky rectifiers
- ESD protection diodes

Key benefits

- More power
- Lower costs
- More functionality
- Improved reliability
- Automotive packages

Low V_{CEsat} (BISS) transistors

These Breakthrough In Small-Signal (BISS) transistors offer best-in-class efficiency, therefore getting the heat out of your applications. These cost-effective alternatives to medium-power transistors deliver 1 – 5 A capability in SOT223 (SC-73), SOT89 (SC-62), SOT23 or SOT457 (SC-74).

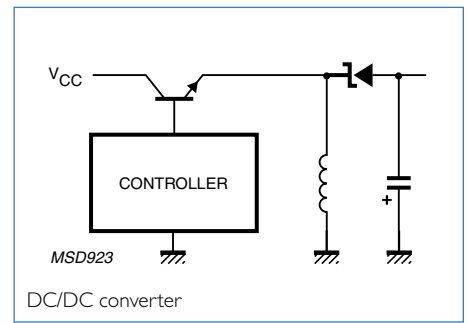

Key features

- Reduced thermal and electrical resistance
- Up to 5 A collector current capability I_C
- Up to 10 A peak collector current I_{CM}
- High performance to boardspace ratio
- High current gain h_{FE} - even at high I_C
- Extensive range of products available

Key benefits

- Less heat generation and therefore use at high ambient temperatures possible
- Cost effective replacement of medium power transistors
- Increased performance from small-signal discrete footprints

Key applications

- Applications where heat is a concern (e.g. engine- or dashboard mounted components)
- High and low side switches, e.g. in control units
- Drivers in low supply voltage applications, e.g. fans, motors
- Inductive load drivers, e.g. relays, buzzers
- MOSFET drivers

Less heat generation with BISS transistors

SOT223: $I_C = 1.55$ A; $I_B = 0.1$ A; PCB FR4 + 1 cm² Cu

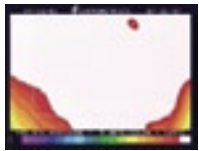

BCP51, $T_j = 130^\circ\text{C}$

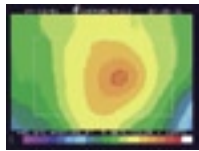



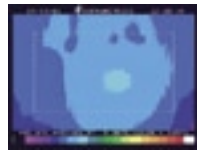

PBSS9110Z, $T_j = 103^\circ\text{C}$

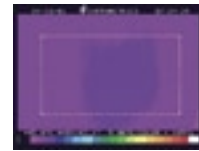

PBSS5350Z, $T_j = 60^\circ\text{C}$



PBSS5540Z, $T_j = 45^\circ\text{C}$

		SOT223 (SC-73)		SOT89 (SC-62)		SOT23		SOT457 (SC-74)	
									
I_C (A)	V_{CE0} (V)	P_{tot} 2000 mW		P_{tot} 1300 mW		P_{tot} 480 mW		P_{tot} 750 mW	
		NPN	PNP	NPN	PNP	NPN	PNP	NPN	PNP
1.0	30					PBSS4130T	PBSS5130T		
	40					PBSS4140T	PBSS5140T	PBSS4140DPN (NPN/PNP)	
	60					PBSS4160T	PBSS5160T		
	100	PBSS8110Z	PBSS9110Z			PBSS8110T	PBSS9110T	PBSS8110D	PBSS9110D
2.0	30					PBSS4230T	PBSS5230T		
	40					PBSS4240T	PBSS5240T	PBSS4240DPN (NPN/PNP)	
	50			PBSS4250X	PBSS5250X	PBSS4350T	PBSS5350T		
3.0	20			PBSS4320X	PBSS5320X				
	30			PBSS4330X	PBSS5330X				
	50	PBSS4350Z	PBSS5350Z	PBSS4350X	PBSS5350X			PBSS4350D	PBSS5350D
	60							PBSS303ND	PBSS303PD
	80							PBSS304ND	PBSS304PD
4.0	100							PBSS305ND	PBSS305PD
	40	PBSS4540Z	PBSS5540Z	PBSS4540X	PBSS5540X			PBSS4440D	PBSS5440D
	80			PBSS4480X	PBSS5480X				
5.0	20			PBSS4520X	PBSS5520X				

Resistor-equipped transistors (RETs)

Developed especially for the automotive sector, 500 mA RETs combine a transistor with two resistors to provide an optimal integrated solution for digital applications in automotive systems, for example control units. Also an extensive portfolio with single and double 100 mA RETs is available for standard small-signal digital applications.

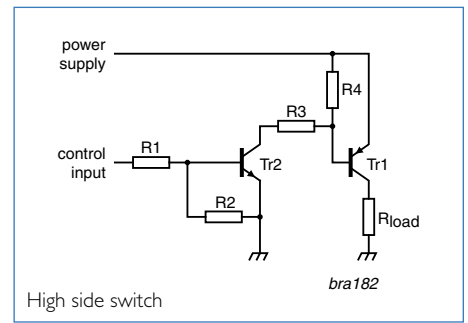

Key features



- Transistor and two resistors integrated in one package
- Initial 500 mA portfolio with several resistor combinations in SOT23 and SOT346 (SC-59A)
- Further resistor combinations and double versions are planned

Key benefits

- Lower handling and inventory costs
- Reduced boardspace requirements
- Shorter assembly times and reduced pick-and-place efforts
- Simpler design process
- Increased end product reliability due to fewer soldering points

Key applications

- Digital applications
- Switching loads, e.g. for instrument clusters
- Controlling IC inputs, e.g. in engine control units

500 mA RETs				SOT23		SOT346 (SC-59A)			
I _C max. (mA)	V _{CEO} max. (V)	R1 (kΩ)	R2 (kΩ)						
				NPN	PNP	NPN	PNP		
				1	1	PDTD113ET	PDTB113ET	PDTD113EK	PDTB113EK
				2.2	2.2	PDTD123ET	PDTB123ET	PDTD123EK	PDTB123EK
500	50	1	10	PDTD113ZT	PDTB113ZT	PDTD113ZK	PDTB113ZK		
				2.2	10	PDTD123YT	PDTB123YT	PDTD123YK	PDTB123YK

100 mA RETs				SOT23		SOT323 (SC-70)		SOT363 (SC-88)			
Configuration				single		double					
I _C max. (mA)	V _{CEO} max. (V)	R1 (kΩ)	R2 (kΩ)	NPN	PNP	NPN	PNP	NPN/PNP	NPN/PNP	PNP/PNP	
				R1 = R2		R1 ≠ R2		Only R1			
100	50	2.2	2.2	PDTC123ET	PDTA123ET	PDTC123EU	PDTA123EU	PUMH20	PUMD20	PUMB20	
				PDTC143ET	PDTA143ET	PDTC143EU	PDTA143EU	PUMH15	PUMD15	PUMB15	
				PDTC114ET	PDTA114ET	PDTC114EU	PDTA114EU	PUMH11	PUMD3	PUMB11	
				PDTC124ET	PDTA124ET	PDTC124EU	PDTA124EU	PUMH1	PUMD2	PUMB1	
				PDTC144ET	PDTA144ET	PDTC144EU	PDTA144EU	PUMH2	PUMD12	PUMB2	
				PDTC115ET	PDTA115ET	PDTC115EU	PDTA115EU	PUMH24	PUMD24	PUMB24	
		4.7	10	10	PDTC123YT	PDTA123YT	PDTC123YU	PDTA123YU			
					PDTC123JT	PDTA123JT	PDTC123JU	PDTA123JU	PUMH10	PUMD10	PUMB10
					PDTC143XT	PDTA143XT	PDTC143XU	PDTA143XU	PUMH18	PUMD18	PUMB18
					PDTC143ZT	PDTA143ZT	PDTC143ZU	PDTA143ZU	PUMH13	PUMD13	PUMB13
					PDTC114YT	PDTA114YT	PDTC114YU	PDTA114YU	PUMH9	PUMD9	PUMB9
					PDTC124XT	PDTA124XT	PDTC124XU	PDTA124XU	PUMH16	PUMD16	PUMB16
		4.7	47	47	PDTC144VT	PDTA144VT	PDTC144VU	PDTA144VU			
					PDTC144WT	PDTA144WT	PDTC144WU	PDTA144WU	PUMH17	PUMD17	PUMB17
					PDTC123TT	PDTA123TT	PDTC123TU	PDTA123TU	PUMH30	PUMD30	PUMB30
					PDTC143TT	PDTA143TT	PDTC143TU	PDTA143TU	PUMH7	PUMD6	PUMB3
					PDTC114TT	PDTA114TT	PDTC114TU	PDTA114TU	PUMH4	PUMD4	PUMB4
					PDTC124TT	PDTA124TT	PDTC124TU	PDTA124TU	PUMH19	PUMD19	PUMB19
100	-	-	PDTC144TT	PDTA144TT	PDTC144TU	PDTA144TU	PUMH14	PUMD14	PUMB14		
			PDTC115TT	PDTA115TT	PDTC115TU	PDTA115TU					

BISS Loadswitches

Combining a BISS transistor with a RET, BISS Loadswitches provide full miniature loadswitch functionality in a single package and deliver best-in-class performance.

Key features

- BISS transistor and RET in one package
- Low “threshold” voltage (< 1 V) compared to MOSFET
- Small drive power required
- Best-in-class performance for loadswitches
- Available for switching loads of 0.5 – 1 A

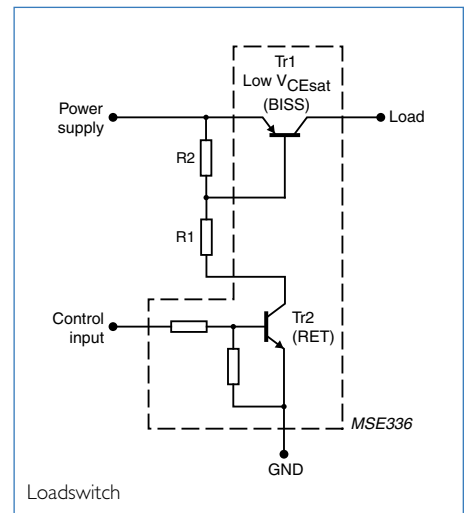

Key benefits

- Integrated on-the-shelf solution for switching loads
 - Saves design and sourcing costs
 - Reduction in boardspace requirements
 - Just one or two external resistors needed for full loadswitch capability
- Combination of low voltage drop and low base drive current
 - BISS transistor in the power path provides the lowest energy-losses
 - RET in the control path provides a low base drive current



Key applications

- Supply line switches, e.g. in control units
- Control of lamps, motors and switches, e.g. instrument clusters
- High side switches for drivers

				SOT457 (SC-74)	SOT363 (SC-88)	
I_c (A)	V_{CE0} (V)	V_{CEsat} (mV) @ 500 mA	R1 = R2 (kΩ)			
0.5	40	350	2.2		PBLS4001Y	
			4.7		PBLS4002Y	
			10		PBLS4003Y	
			22		PBLS4004Y	
			47		PBLS4005Y	
1.0	40	170	2.2	PBLS4001D		
			4.7	PBLS4002D		
			10	PBLS4003D		
			22	PBLS4004D		
			47	PBLS4005D		
	60	180	180	2.2	PBLS6001D	
				4.7	PBLS6002D	
				10	PBLS6003D	
				22	PBLS6004D	
				47	PBLS6005D	

Matched pair transistors

Matched pair transistors are double transistors with matched current gain h_{FE1}/h_{FE2} and matched base-emitter voltage $V_{BE1} - V_{BE2}$. The optimal product for the most common applications is offered by means of several matching-categories and different pinning options. Internally the transistors are fully isolated.

Key features

- Current gain matching:
 $h_{FE1}/h_{FE2} = 0.7, 0.9, 0.95, 0.98$
- Base-emitter voltage matching:
 $V_{BE1} - V_{BE2} = 2 \text{ mV}$
- Standard double transistor pin-out for BCM-types
- Application optimized pin-out for all PMP-types
- Common emitter configuration for 5pin PMP-types



Key benefits

- Improved performance of current mirror and differential amplifier circuits
- Drop-in replacement for standard double transistors (BCM-series)
- Simplified board layout (PMP-series)
- Eliminates need for costly additional trimming

Key applications

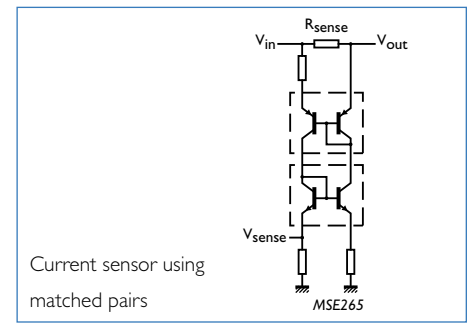
- Current mirror e.g. for current measurement or to drive LED's with a constant current
- Differential amplifier e.g. sensor signal amplification
- Comparator e.g. for DC/DC converters



							SOT143B	SOT457 (SC-74)	SOT353 (SC-88A)	SOT363 (SC-88)
										
							250 mW	380 mW	300 mW	300 mW
P_{tot} max.										
Polarity	I_C (mA)	V_{CEO} (V)	h_{FE} min.	h_{FE} max.	h_{FE1}/h_{FE2}	$V_{BE1} - V_{BE2}$ (mV)				
NPN	100	30	110	800	0.7	n.a.	BCV61/A/B/C			
					0.9	2	BCM61B			
		45	200	450	0.9	2		BCM847DS		
					0.95	2			PMP4501G	BCM847BS
					0.98	2			PMP4201G	PMP4201Y
PNP	100	30	110	800	0.7	n.a.	BCV62/A/B/C			
					0.9	2	BCM62B			
		45	200	450	0.9	2		BCM857DS		
					0.95	2			PMP5501G	BCM857BS
					0.98	2			PMP5201G	PMP5201Y

MOSFET drivers

Integrated discrete MOSFET drivers combine several discrete products into one package to offer MOSFET driving functionality. With a choice of configurations Philips offers solutions to take load from the driving circuit, improve the efficiency of the MOSFET and enable design flexibility.

Key features





- Complete MOSFET driving functionality in one package
- Several configurations available

Key benefits

- Improved MOSFET efficiency by
 - Minimizing rise and fall time
 - Fast gate (dis-)charge of the driven MOSFET
- Takes load from the driving circuit and thus minimizes the IC power dissipation
- More design flexibility: the control IC and the MOSFET do not have to be placed as close as possible anymore
- Cost-effective alternative to IC-solutions

Key applications

- MOSFET driver
- Bipolar power transistor driver
- Push-pull driver

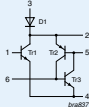
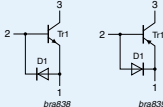
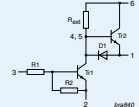
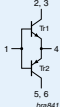
			SOT457 (SC-74)	SOT346 (SC-59A)	SOT457 (SC-74)	SOT457 (SC-74)
Configuration						
						
P _{tot} max.			600 mW	250 mW	600 mW	600 mW
Contains		I _C (A)	I _{CM} (A)		R1 = R2 (kΩ)	
General purpose transistors		0.1	0.2	PMD9050D		PMD4001K (NPN) PMD5001K (PNP)
Switching transistors - reduced storage time		0.6	1.2	PMD4002K (NPN) PMD5002K (PNP)		PMD9010D PMD9001D PMD9002D PMD9003D
Low V _{CEsat} (BISS) transistors -		1.0	2.0	PMD4003K (NPN) PMD5003K (PNP)		PMD2001D PMD3001D

Release mid 2006

Low V_F (MEGA) Schottky rectifiers

Maximum Efficiency General Application (MEGA) Schottky rectifiers offer extremely low forward voltage drop during operation, resulting in the highest efficiency and reduced heat dissipation. They are ideal, cost-effective replacements for rectifiers in SMA or SOD123.



Key features





- Ultra low forward voltage drop V_F
- Up to 3 A continuous current capability I_F
- Up to 10 A peak current capability I_{FSM}
- Low power dissipation
- Integrated guard ring for stress protection

Key benefits

- Less heat generation and therefore increased reliability
- Cost effective replacement of SMA and SOD123 rectifiers
 - Reduced boardspace requirements
 - Medium power capability in SOD323F (SC-90)
- Low losses over the entire current range
- Improved current handling capability
- Increased performance from small-signal discrete footprints

Key applications

- Power management circuits – especially DC/DC conversion
- Various rectifier circuits, e.g. in airbag control units
- Low power applications, e.g. in control units
- Free wheeling diode for inductive loads in relays and motors
- Reverse polarity protection, e.g. in car multimedia applications

					SOT457 (SC-74)	SOT23	SOD123F	SOD323F (SC-90)
I_F max. (A)	V_R max. (V)	I_{FSM} (A)	V_F max. (mV)	I_r max. (μ A) @ V_F max.				
0.5	20	6	390	200		PMEG2005ET	PMEG2005EH	PMEG2005EJ
	30	10	430	150		PMEG3005ET	PMEG3005EH	PMEG3005EJ
	40	10	470	100		PMEG4005ET	PMEG4005EH	PMEG4005EJ
1	20	9	500	200			PMEG2010EH	PMEG2010EJ
		10	550	70			PMEG2010AEJ	
	30	9	430	200			PMEH2010AEH	
		10	560	150			PMEG3010EH	PMEG3010EJ
	40	10	520	50				PMEG3010CEJ
		10	640	100			PMEG4010EH	PMEG4010EJ
60	10	660	50				PMEG6010CEJ	
1.5	20	17.5	650	350	PMEG6010AED			
			70				PMEG2015EH	PMEG2015EJ
	30	9	550	1000			PMEG3015EH	PMEG3015EJ
2	10	9	460	3000			PMEG1020EH	PMEG1020EJ
	20	9	525	200			PMEG2020EH	PMEG2020EJ
		9	620	1000			PMEG3020EH	PMEG3020EJ
3	10	9	530	3000			PMEG1030EH	PMEG1030EJ

ESD protection diodes

With their optimized diode structure, Philips' ESD protection diodes offer a superior size / performance ratio with outstanding ESD protection of automotive electronics. A wide portfolio is available for protection of all interfaces in automotive electronics; from general line-protection for engine/body -controllers up to specific devices for protection of USB-interfaces or antenna-inputs in car entertainment applications.

Key features



- Excellent ESD clamping performance
- Ultra low leakage current
- Low device capacitance
- ESD protection up to 30 kV
- IEC 61000-4-2, level 4 compliant (8 kV contact, 15 kV air discharge)

Key benefits

- Optimized diode structure for best-in-class ESD protection of today's sensitive car electronics
- Low clamping voltages and fast response times ensure optimal protection
- Ultra low leakage current helps to reduce overall power consumption
- Low device capacitance keeps unwanted disturbances in the circuits to a minimum

Key applications

- Data and audio interfaces, e.g. car multimedia line protection
- Overvoltage protection, e.g. airbag controllers
- Car drivers interface protection, e.g. dashboard panels
- CAN and LIN bus protection

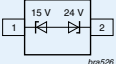
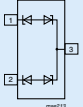
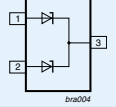
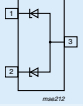
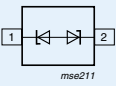
Configuration	Number of lines						SOT23	SOD323 (SC-76)
	uni-directional	bi-directional	I_{RM} max. @ V_{RWM} μA	V	C max. pF	P_{PP} max. W		
 bra528		1	0.05	15	13	160		PESD1LIN
 mma212		2	0.05	24	17	200	PESD1CAN	
 bra004	2	1	1	5	200	260	PESD5V0S2UAT	
	2	1	0.05	12	75	180	PESD12VS2UAT	
	2	1	0.05	24	50	160	PESD24VS2UAT	
 mma212	2	1	1	5.25	200	260	PESD5V2S2UT	
	2	1	1	12	75	180	PESD12VS2UT	
	2	1	1	24	50	160	PESD24VS2UT	
 mma211		1	1	5	65	500		PESD5V0L1BA
		1	0.05	12	13	200		PESD12VL1BA
		1	0.05	24	9	200		PESD24VL1BA

PESD1LIN and PESD1CAN

Also specific automotive devices are available; with the PESD1LIN Philips offers the best-in-class ESD protection of one LIN bus line. The asymmetrical diode configuration ensures optimized electromagnetic immunity of LIN transceivers. The PESD1CAN is designed to protect two CAN bus lines and can be used for both high speed CAN bus and the fault-tolerant CAN bus protection. With the very low C_{max} of the PESD1CAN the unwanted parasitic capacitance is reduced to an absolute minimum.

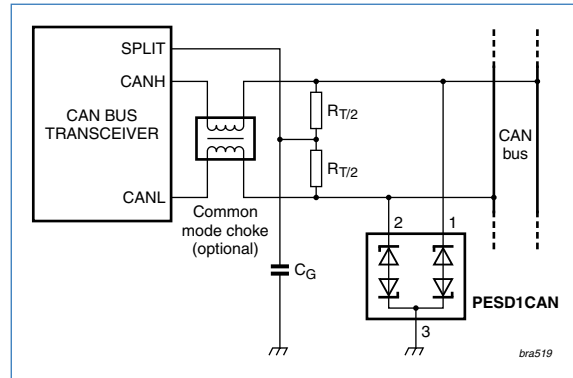
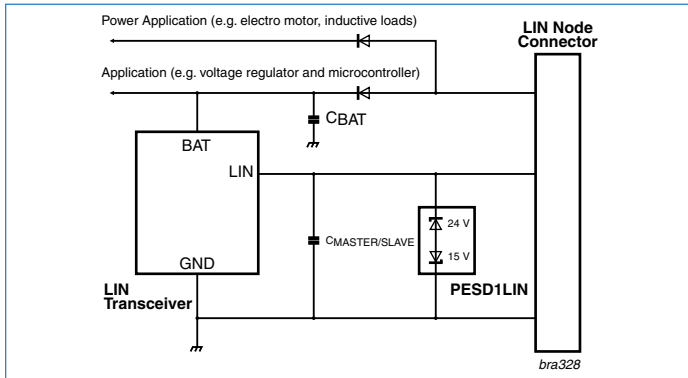

Small-signal discretes packages for automotive

Series	Philips name JEITA	Body size (mm) l x w x h	Pins
S-mini	SOD323F	1.7 x 1.25 x 0.7	2
	SC-90		flatleads
	SOD323	1.7 x 1.25 x 0.95	2
	SC-76		
	SOD123F	2.6 x 1.6 x 1.1	2
			flatleads
	SOT323	2.0 x 1.25 x 0.95	3
	SC-70		
	SOT353	2.0 x 1.25 x 0.95	5
Mini	SC-88A		
	SOT363	2.0 x 1.25 x 0.95	6
	SC-88		
	SOT23	2.9 x 1.3 x 1.0	3
	SOT346	2.9 x 1.5 x 1.15	3
Medium power	SC-59		
	SOT143B	2.9 x 1.3 x 1.0	4
	SOT457	2.9 x 1.5 x 1.0	6
	SC-74		
	SOT89	4.5 x 2.5 x 1.25	3
	SC-62		flatleads
	SOT223	6.5 x 3.5 x 1.65	3/4
	SC-73		



Philips Semiconductors

Philips Semiconductors is one of the world's top semiconductor suppliers, with 20 manufacturing and assembly sites and a sales organization that delivers in 60 countries. For a complete up-to-date list of our sales offices please visit our website <http://www.semiconductors.philips.com/sales>

©2006 Koninklijke Philips Electronics N.V.

All rights reserved. Reproduction in whole or in part is prohibited without the prior written consent of the copyright owner. The information presented in this document does not form part of any quotation or contract, is believed to be accurate and reliable and may be changed without notice. No liability will be accepted by the publisher for any consequence of its use. Publication thereof does not convey nor imply any license under patent- or other industrial or intellectual property rights.

Date of release: May 2006

Document order number: 9397 750 15548

Printed in the Netherlands