

# HI-506, HI-507, HI-508, HI-509

## Single 16 and 8/Differential 8-Channel and 4-Channel CMOS Analog Multiplexers

August 1997

### Features

- **Low ON Resistance** ..... 180Ω
- **Wide Analog Signal Range** ..... ±15V
- **TTL/CMOS Compatible**
- **Access Time** ..... 250ns
- **Maximum Power Supply** ..... 44V
- **Break-Before-Make Switching**
- **No Latch-Up**
- **Replaces DG506A/DG506AA and DG507A/DG507AA**
- **Replaces DG508A/DG508AA and DG509A/DG509AA**

### Applications

- **Data Acquisition Systems**
- **Precision Instrumentation**
- **Demultiplexing**
- **Selector Switch**

### Description

The HI-506/HI-507 and HI-508/HI-509 monolithic CMOS multiplexers each include an array of sixteen and eight analog switches respectively, a digital decoder circuit for channel selection, voltage reference for logic thresholds, and an enable input for device selection when several multiplexers are present. The Dielectric Isolation (DI) process used in fabrication of these devices eliminates the problem of latchup. DI also offers much lower substrate leakage and parasitic capacitance than conventional junction isolated CMOS (see Application Note AN521).

The switching threshold for each digital input is established by an internal +5V reference, providing a guaranteed minimum 2.4V for logic "1" and maximum 0.8V for logic "0". This allows direct interface without pullup resistors to signals from most logic families: CMOS, TTL, DTL and some PMOS. For protection against transient overvoltage, the digital inputs include a series 200Ω resistor and diode clamp to each supply.

The HI-506 is a single 16-Channel, the HI-507 is an 8-Channel differential, the HI-508 is a single 8-Channel and the HI-509 is a 4-Channel differential multiplexer. The HI-506/HI-507 are available in a 28 lead ceramic or plastic DIP, 28 pad leadless chip carrier (CLCC), 28 pin plastic leaded chip carrier (PLCC) and 28 lead SOIC packages. The HI-508/HI-509 are available in a 16 pin plastic or ceramic DIP, a 20 pin plastic leaded chip carrier (PLCC), 20 pad ceramic leadless chip carrier (CLCC) and 16 lead SOIC packages.

If input overvoltages are present, the HI-546/HI-547/HI-548/HI-549 multiplexers are recommended. For further information see Application Notes AN520 and AN521. The HI-506/HI-507/HI-508/HI-509 is offered in both commercial and military grades. For additional High Reliability Screening including 160 hour burn-in specify the "-8" suffix. For MIL-STD-883 compliant parts, request the HI-506/883, HI-507/883, HI-508/883 or HI-509/883 data sheet.

## HI-506, HI-507, HI-508, HI-509

### Ordering Information

PART NUMBER	TEMP. RANGE (°C)	PACKAGE	PKG. NO.
HI1-0506/883	-55 to 125	28 Ld CERDIP	F28.6
HI1-0506-8	Hi-Rel Pressing with Burn-In	28 Ld CERDIP	F28.6
HI4-0506/883	-55 to 125	28 Ld CLCC	J28.A
HI1-0507/883	-55 to 125	28 Ld CERDIP	F28.6
HI9P0506-9	-40 to 85	28 Ld SOIC	M28.6
HI3-0506-5	0 to 75	28 Ld PDIP	E28.6
HI1-0506-7	0 to 75 + 96 Hour Burn-In	28 Ld CERDIP	F28.6
HI9P0506-5	0 to 75	28 Ld SOIC	M28.3
HI1-0506-5	0 to 75	28 Ld CERDIP	F28.6
HI1-0506-4	-25 to 85	28 Ld CERDIP	F28.6
HI1-0506-2	-55 to 125	28 Ld CERDIP	F28.6
HI1-0507-8	Hi-Rel Pressing with Burn-In	28 Ld CERDIP	F28.6
HI4-0507/883	-55 to 125	28 Ld CLCC	J28.A
HI1-0507-4	-25 to 85	28 Ld CERDIP	F28.6
HI4P0507-5	0 to 75	28 Ld PLCC	N28.45
HI9P0507-5	0 to 75	28 Ld SOIC	M28.3
HI1-0507-5	0 to 75	28 Ld CERDIP	F28.6
HI3-0507-5	0 to 75	28 Ld PDIP	E28.3
HI9P0507-9	-40 to 85	28 Ld SOIC	M28.3
HI1-0507-2	-55 to 125	28 Ld CERDIP	F28.6
HI1-0508/883	-55 to 125	16 Ld CERDIP	F16.3

PART NUMBER	TEMP. RANGE (°C)	PACKAGE	PKG. NO.
HI1-0508-8	Hi-Rel Pressing with Burn-In	16 Ld CERDIP	F16.3
HI4-0508/883	-55 to 125	20 Ld CLCC	J20.A
HI1-0509/883	-55 to 125	16 Ld CERDIP	F16.3
HI1-0508-5	0 to 75	16 Ld CERDIP	F16.3
HI3-0508-5	0 to 75	16 Ld PDIP	E16.3
HI1-0508-4	-25 to 85	16 Ld CERDIP	F16.3
HI1-0508-2	-55 to 125	16 Ld CERDIP	F16.3
HI4P0508-5	0 to 75	20 Ld PLCC	N20.35
HI9P0508-9	-40 to 85	16 Ld SOIC	M16.15
HI9P0508-5	0 to 75	16 Ld SOIC	M16.15
HI1-0509-8	Hi-Rel Pressing with Burn-In	16 Ld CERDIP	F16.3
HI4-0509/883	-55 to 125	20 Ld CLCC	J20.A
HI9P0509-5	0 to 75	16 Ld SOIC	M16.15
HI9P0509-9	-40 to 85	16 Ld SOIC	M16.15
HI1-0509-4	-25 to 85	16 Ld CERDIP	F16.3
HI1-0509-5	0 to 75	16 Ld CERDIP	F16.3
HI3-0509-5	0 to 75	16 Ld PDIP	E16.3
HI4P0509-5	0 to 75	20 Ld PLCC	N20.35
HI1-0509-2	-55 to 125	16 Ld CERDIP	F16.3
HI1-0509-7	0 to 75 + 96 Hour Burn-In	16 Ld CERDIP	F16.3

# HI-506, HI-507, HI-508, HI-509

## Pinouts

**HI-506**  
(PDIP, CERDIP, SOIC)  
TOP VIEW

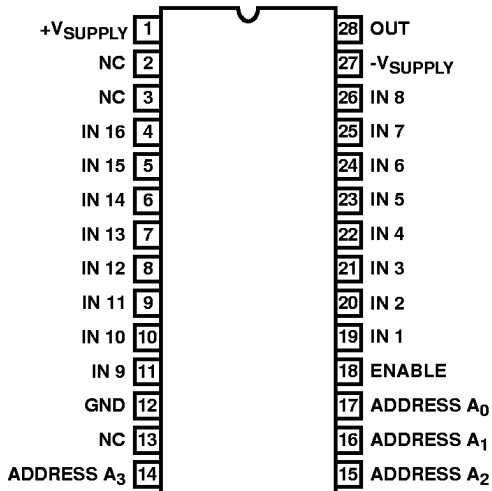

**HI-507**  
(PDIP, CERDIP, SOIC)  
TOP VIEW

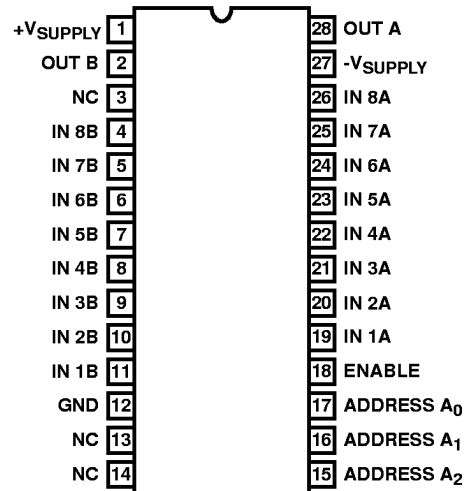

**HI-506**  
(CLCC, PLCC)  
TOP VIEW

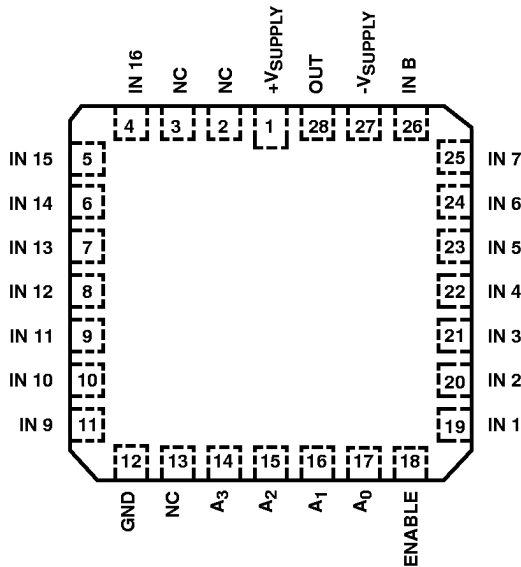

**HI-507**  
(CLCC, PLCC)  
TOP VIEW

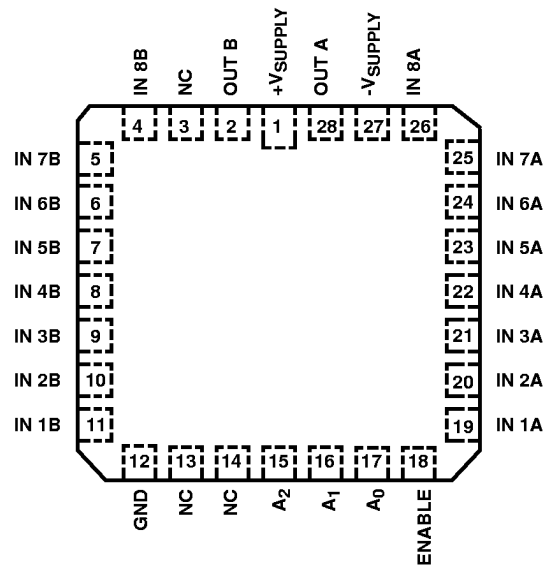

# HI-506, HI-507, HI-508, HI-509

## Pinouts (Continued)

**HI-508**  
(PDIP, CERDIP, SOIC)  
TOP VIEW

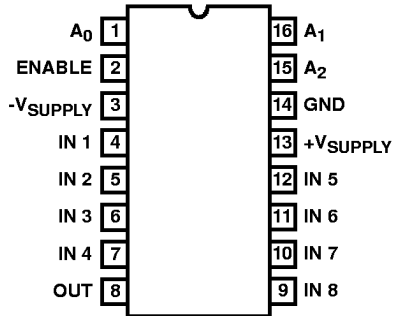

**HI-509**  
(PDIP, CERDIP, SOIC)  
TOP VIEW

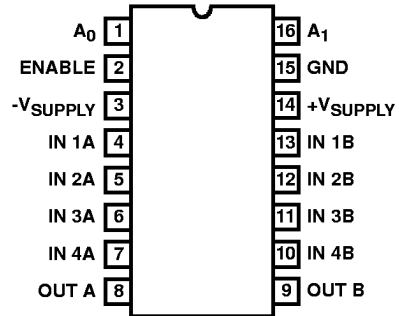

**HI-508**  
(CLCC, PLCC)  
TOP VIEW

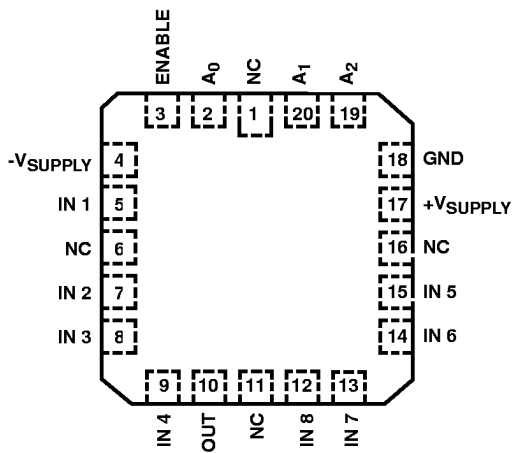

**HI-509**  
(CLCC, PLCC)  
TOP VIEW

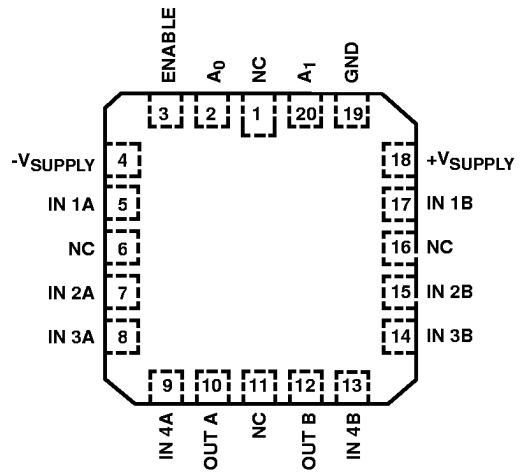

Functional Diagrams

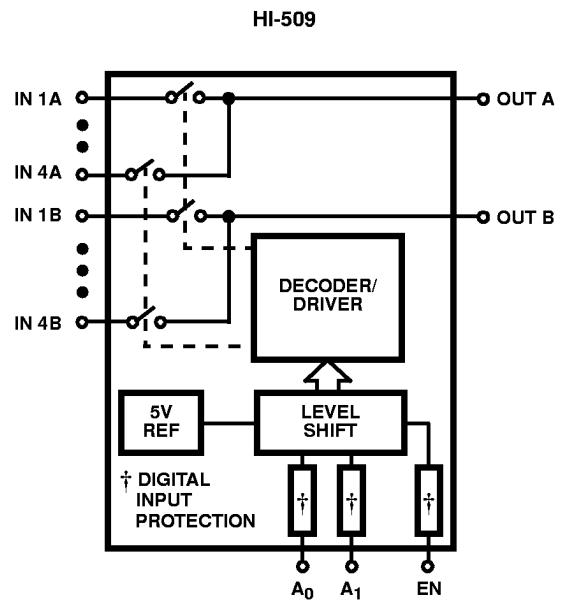
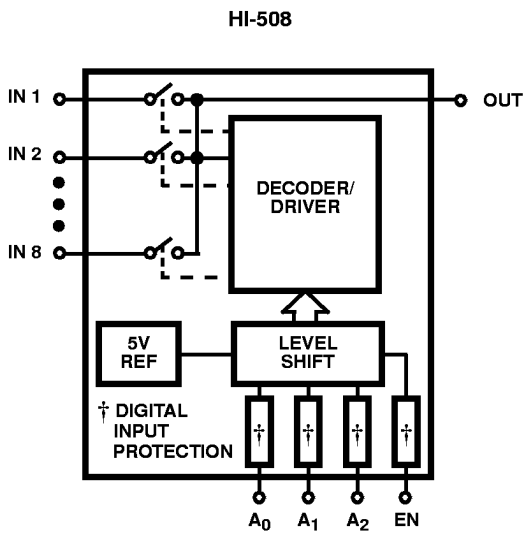
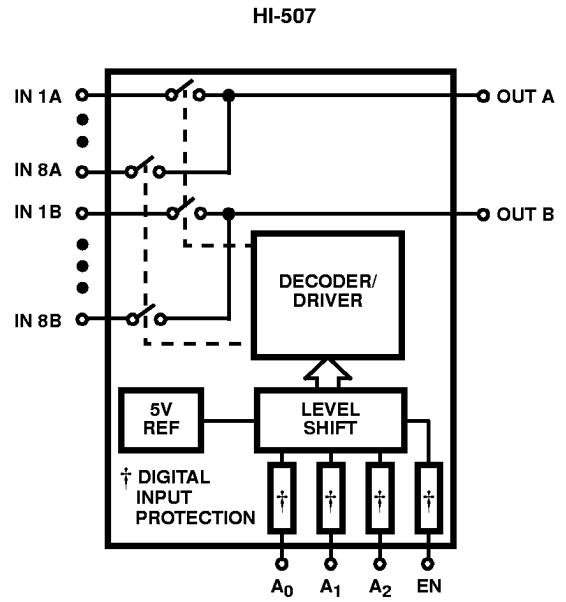
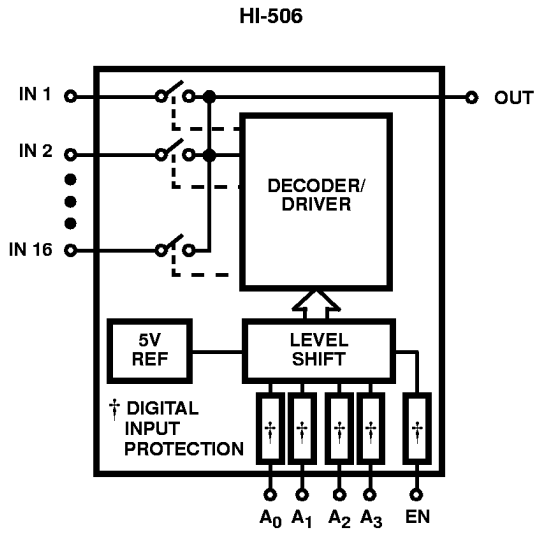

Schematic Diagrams

ADDRESS DECODER

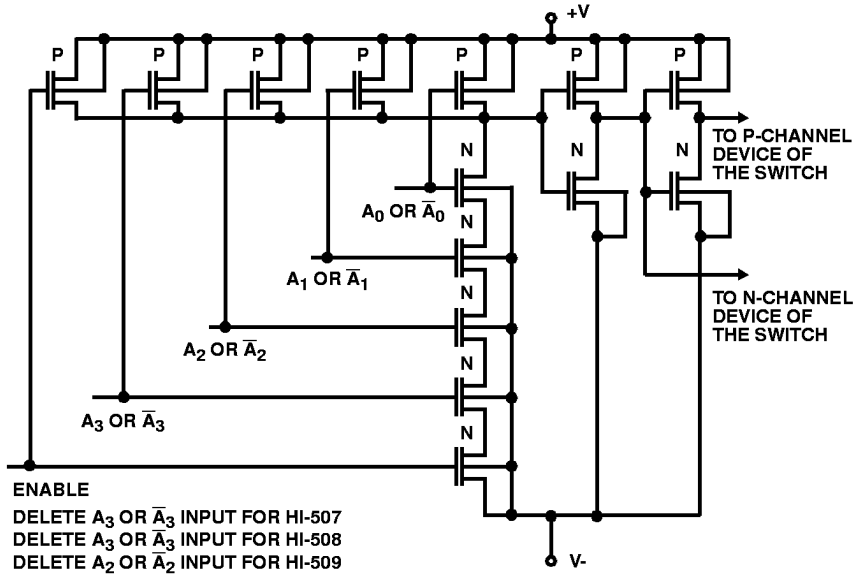

ADDRESS INPUT BUFFER LEVEL SHIFTER

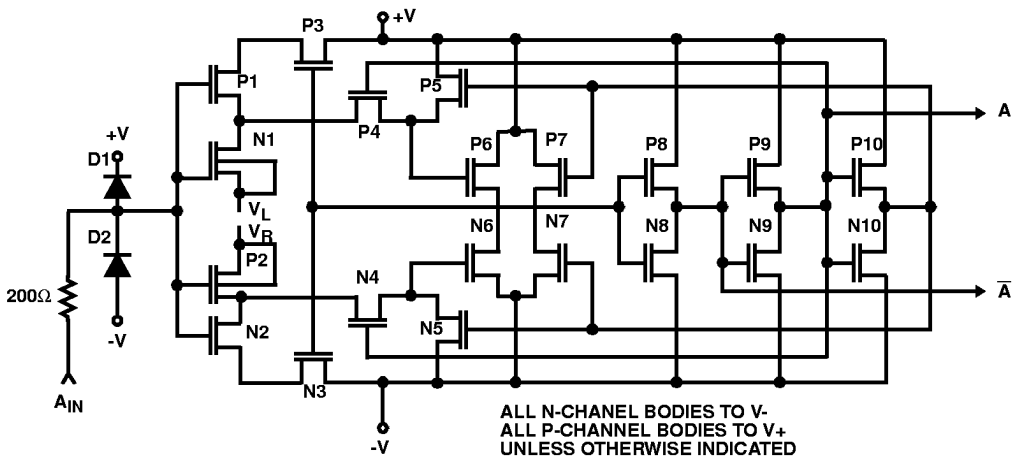

TTL REFERENCE CIRCUIT

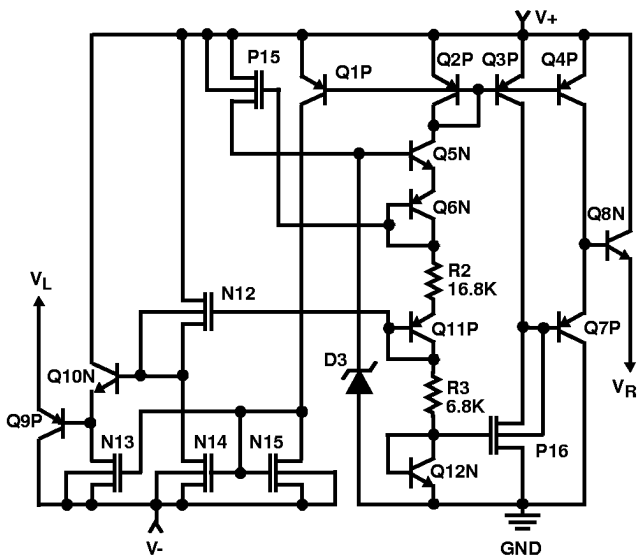

MULTIPLEX SWITCH

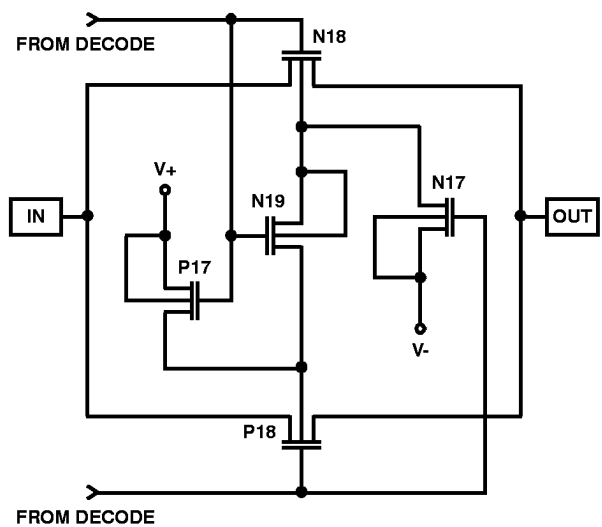

# HI-506, HI-507, HI-508, HI-509

## Absolute Maximum Ratings

V <sub>SUPPLY(+)</sub> to V <sub>SUPPLY(-)</sub> .....	+44V
V <sub>SUPPLY(+)</sub> to GND .....	+22V
V <sub>SUPPLY(-)</sub> to GND .....	-25V
Digital Input Overvoltage	
+V <sub>EN</sub> , +V <sub>A</sub> .....	+V <sub>SUPPLY</sub> +4V
-V <sub>EN</sub> , -V <sub>A</sub> .....	-V <sub>SUPPLY</sub> -4V
	or 20mA, Whichever Occurs First
Analog Signal Overvoltage (Note 7)	
+V <sub>S</sub> .....	+V <sub>SUPPLY</sub> +2V
-V <sub>S</sub> .....	-V <sub>SUPPLY</sub> -2V
Continuous Current, S or D .....	20mA
Peak Current, S or D .....	40mA
	(Pulsed at 1ms, 10% Duty Cycle Max)

## Operating Conditions

Temperature Ranges	
HI-506/507/508/509-2, -8 .....	-55°C to 125°C
HI-506/507/508/509-4 .....	-25°C to 85°C
HI-506/507/508/509-5 .....	0°C to 75°C

*CAUTION: Stresses above those listed in "Absolute Maximum Ratings" may cause permanent damage to the device. This is a stress only rating and operation of the device at these or any other conditions above those indicated in the operational sections of this specification is not implied.*

### NOTE:

1.  $\theta_{JA}$  is measured with the component mounted on an evaluation PC board in free air.

## Thermal Information

Thermal Resistance (Typical, Note 1)	$\theta_{JA}$ (°C/W)	$\theta_{JC}$ (°C/W)
16 Ld CERDIP Package .....	85	32
16 Ld SOIC Package .....	115	N/A
16 Ld PDIP Package .....	100	N/A
20 Ld CLCC Package .....	80	28
20 Ld PLCC Package .....	80	N/A
28 Ld CERDIP Package .....	55	18
28 Ld PDIP Package .....	60	N/A
28 Ld SOIC Package .....	70	N/A
28 Ld CLCC Package .....	70	20
28 Ld PLCC Package .....	70	N/A
Maximum Junction Temperature		
Ceramic Package .....		175°C
Plastic Package .....		150°C
Maximum Storage Temperature Range .....		-65°C to 150°C
Maximum Lead Temperature (Soldering 10s) .....		300°C
		(SOIC and PLCC - Lead Tips Only)

## Electrical Specifications

Supplies = +15V, -15V; V<sub>AH</sub> (Logic Level High) = +2.4V; V<sub>AL</sub> (Logic Level Low) = +0.8V, Unless Otherwise Specified. For Test Conditions, Consult Performance Curves

PARAMETER	TEST CONDITIONS	TEMP (°C)	HI-5XX-2, HI-5XX-8			HI-5XX-4, HI-5XX-5			UNITS
			MIN	TYP	MAX	MIN	TYP	MAX	
<b>SWITCHING CHARACTERISTICS</b>									
Access Time, $t_A$	(Note 1)	25	-	250	500	-	250	-	ns
		Full	-	-	1000	-	-	1000	ns
Break-Before-Make Delay, $t_{OPEN}$	(Note 1)	25	25	80	-	25	80	-	ns
Enable Delay (ON), $t_{ON(EN)}$	(Note 1)	25	-	250	500	-	250	-	ns
		Full	-	-	1000	-	-	1000	ns
Enable Delay (OFF), $t_{OFF(EN)}$	(Note 1)	25	-	250	500	-	250	-	ns
		Full	-	-	1000	-	-	1000	ns
Settling Time to 0.1%, $t_S$ (HI-506 and HI-507)		25	-	1.2	-	-	1.2	-	$\mu$ s
Settling Time to 0.01%, $t_S$ (HI-506 and HI-507)		25	-	2.4	-	-	2.4	-	$\mu$ s
Settling Time to 0.1%, $t_S$ (HI-508 and HI-509)		25	-	360	-	-	360	-	ns
Settling Time to 0.01%, $t_S$ (HI-508 and HI-509)		25	-	600	-	-	600	-	ns
"Off Isolation"	(Note 5)	25	50	68	-	50	68	-	dB
Channel Input Capacitance, C <sub>S(OFF)</sub>		25	-	10	-	-	10	-	pF
Channel Output Capacitance, C <sub>D(OFF)</sub> (HI-506)		25	-	52	-	-	52	-	pF
Channel Output Capacitance, C <sub>D(OFF)</sub> (HI-507)		25	-	30	-	-	30	-	pF
Channel Output Capacitance, C <sub>D(OFF)</sub> (HI-508)		25	-	17	-	-	17	-	pF
Channel Output Capacitance, C <sub>D(OFF)</sub> (HI-509)		25	-	12	-	-	12	-	pF

## HI-506, HI-507, HI-508, HI-509

**Electrical Specifications** Supplies = +15V, -15V;  $V_{AH}$  (Logic Level High) = +2.4V;  $V_{AL}$  (Logic Level Low) = +0.8V, Unless Otherwise Specified. For Test Conditions, Consult Performance Curves **(Continued)**

PARAMETER	TEST CONDITIONS	TEMP (°C)	HI-5XX-2, HI-5XX-8			HI-5XX-4, HI-5XX-5			UNITS	
			MIN	TYP	MAX	MIN	TYP	MAX		
Digital Input Capacitance, $C_A$		25	-	6	-	-	6	-	pF	
Input to Output Capacitance, $C_{DS(OFF)}$		25	-	0.08	-	-	0.08	-	pF	
<b>DIGITAL INPUT CHARACTERISTICS</b>										
Input Low Threshold, $V_{AL}$	(Note 1)	Full	-	-	+0.8	-	-	+0.8	V	
Input High Threshold, $V_{AH}$	(Note 1)	Full	+2.4	-	-	+2.4	-	-	V	
Input Leakage Current (High or Low), $I_A$	(Notes 1, 4)	Full	-	-	1.0	-	-	1.0	$\mu$ A	
<b>ANALOG CHANNEL CHARACTERISTICS</b>										
Analog Signal Range, $V_S$		Full	-15	-	+15	-15	-	+15	V	
On Resistance, $r_{ON}$	(Notes 1, 2)	25	-	180	300	-	180	400	$\Omega$	
$\Delta r_{ON}$ , (Any Two Channels)		25	-	5	-	-	5	-	%	
Off Input Leakage Current, $I_{S(OFF)}$	(Note 3)	25	-	0.03	-	-	0.03	-	nA	
		Full	-	-	50	-	-	50	nA	
Off Output Leakage Current, $I_{D(OFF)}$	(Note 3)	25	-	0.3	-	-	0.3	-	nA	
		HI-506	Full	-	-	300	-	-	300	nA
		HI-507	Full	-	-	200	-	-	200	nA
		HI-508	Full	-	-	200	-	-	200	nA
		HI-509	Full	-	-	100	-	-	100	nA
On Channel Leakage Current, $I_{D(ON)}$	(Note 3)	25	-	0.3	-	-	0.3	-	nA	
		HI-506	Full	-	-	300	-	-	300	nA
		HI-507	Full	-	-	200	-	-	200	nA
		HI-508	Full	-	-	200	-	-	200	nA
		HI-509	Full	-	-	100	-	-	100	nA
Differential Off Output Leakage Current, $I_{DIFF}$ (HI-507, HI-509 Only)	(Note 1)	Full	-	-	50	-	-	50	nA	
<b>POWER REQUIREMENTS</b>										
Current, $I_+$ , Pin 1 HI-506/HI-507	(Note 6)	Full	-	1.5	3.0	-	1.5	3.0	mA	
Current, $I_+$ , HI-508/HI-509	(Note 6)	Full	-	1.5	2.4	-	1.5	2.4	mA	
Current, $I_-$ , Pin 27 HI-506/HI-507	(Note 6)	Full	-	0.4	1.0	-	0.4	1.0	mA	
Current, $I_-$ , HI-508/HI-509	(Note 6)	Full	-	0.4	1.0	-	0.4	1.0	mA	
Power Dissipation, $P_D$		Full	-	-	60	-	-	60	mW	
		Full	-	-	51	-	-	51	mW	

**NOTES:**

- 100% tested for Dash 8. Leakage currents not tested at -55°C.
- $V_{OUT} = \pm 10V$ ,  $I_{OUT} = \pm 1mA$ .
- 10nA is the practical lower limit for high speed measurement in the production test environment.
- Digital input leakage is primarily due to the clamp diodes (see Schematic). Typical leakage is less than 1nA at 25°C.
- $V_{EN} = 0.8V$ ,  $R_L = 1K$ ,  $C_L = 15pF$ ,  $V_S = 7V_{RMS}$ ,  $f = 100kHz$ .
- $V_{EN}$ ,  $V_A = 0V$  or 2.4V.
- Signal voltage at any analog input or output (S or D) will be clamped to the supply rail by internal diodes. Limit the resulting current as shown under absolute maximum ratings. If an overvoltage condition is anticipated (analog input exceeds either power supply voltage), the Harris HI-546/HI-547/HI-548/HI-549 multiplexers are recommended.



**Typical Performance Curves**  $T_A = 25^\circ\text{C}$ ,  $V_{\text{SUPPLY}} = \pm 15\text{V}$ ,  $V_{\text{AH}} = 2.4\text{V}$ ,  $V_{\text{AL}} = 0.8\text{V}$ , Unless Otherwise Specified

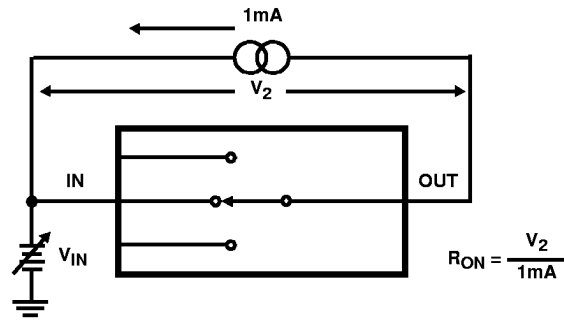

FIGURE 1A. TEST CIRCUIT

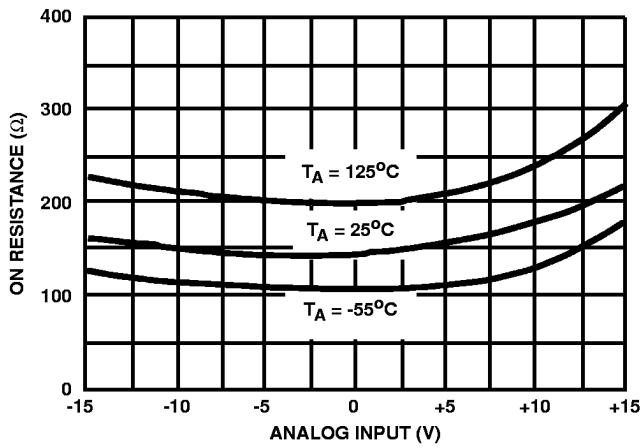

FIGURE 1B. ON RESISTANCE vs ANALOG INPUT VOLTAGE, TEMPERATURE

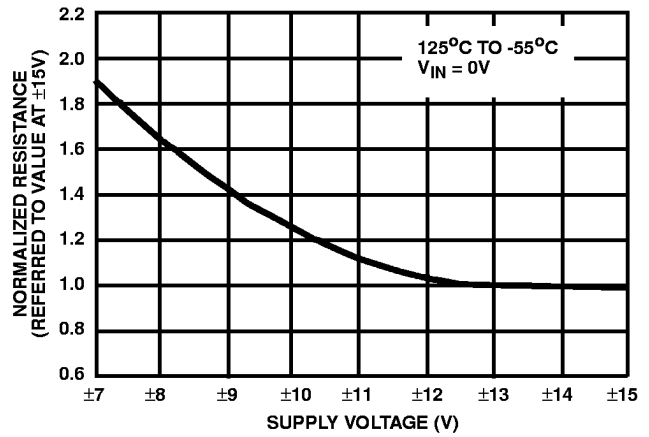

FIGURE 1C. NORMALIZED ON RESISTANCE vs SUPPLY VOLTAGE

FIGURE 1. ON RESISTANCE

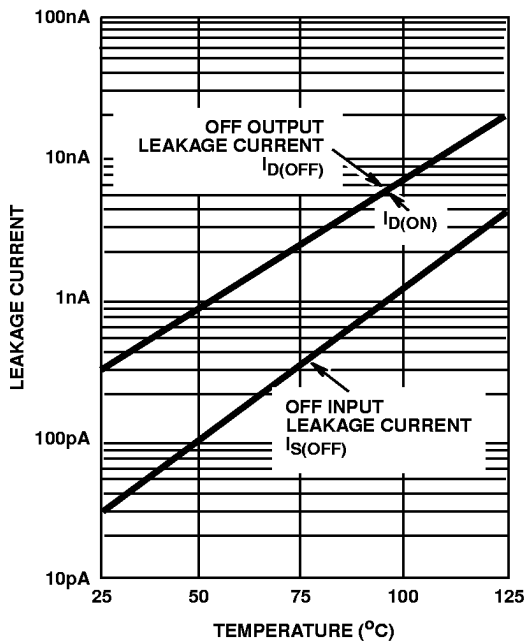

FIGURE 2A. LEAKAGE CURRENT vs TEMPERATURE

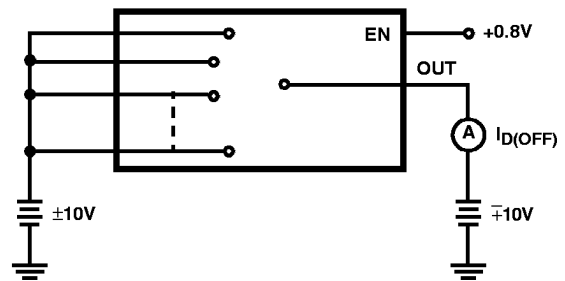

FIGURE 2B.  $I_{D(OFF)}$  TEST CIRCUIT

**Typical Performance Curves**  $T_A = 25^\circ\text{C}$ ,  $V_{\text{SUPPLY}} = \pm 15\text{V}$ ,  $V_{\text{AH}} = 2.4\text{V}$ ,  $V_{\text{AL}} = 0.8\text{V}$ , Unless Otherwise Specified (Continued)

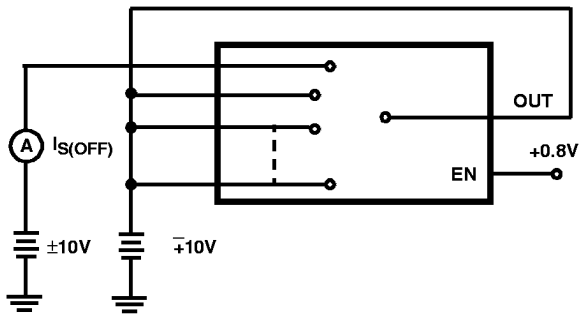

FIGURE 2C.  $I_{\text{S(OFF)}}$  TEST CIRCUIT

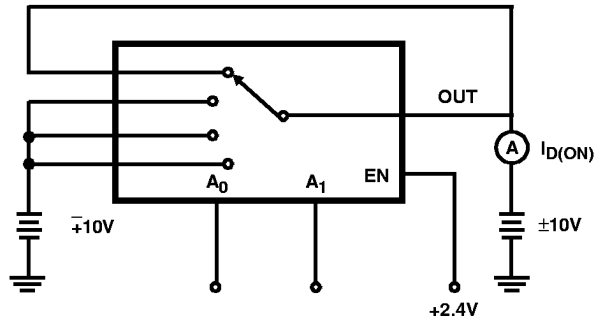

FIGURE 2D.  $I_{\text{D(ON)}}$  TEST CIRCUIT

FIGURE 2. ON RESISTANCE

NOTE:

1. Two measurements per channel: +10V/-10V and -10V/+10V. (Two measurements per device for  $I_{\text{D(OFF)}}$  +10V/-10V and -10V/+10V.)

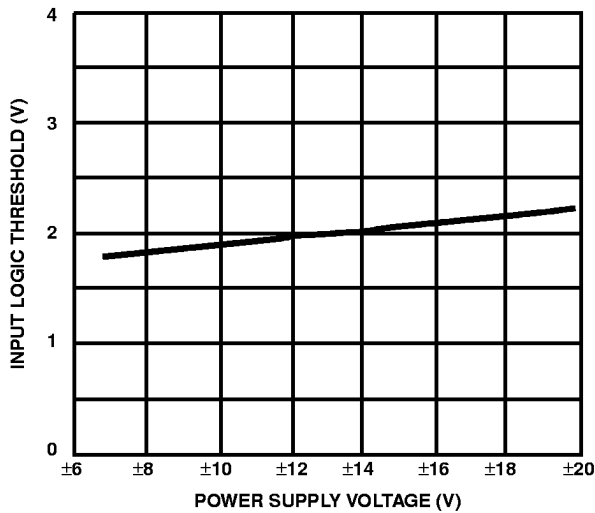

FIGURE 3. LOGIC THRESHOLD vs POWER SUPPLY VOLTAGE

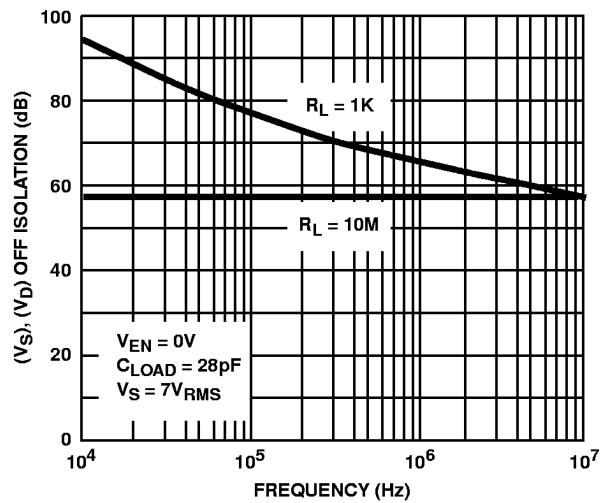

FIGURE 4. OFF ISOLATION vs FREQUENCY

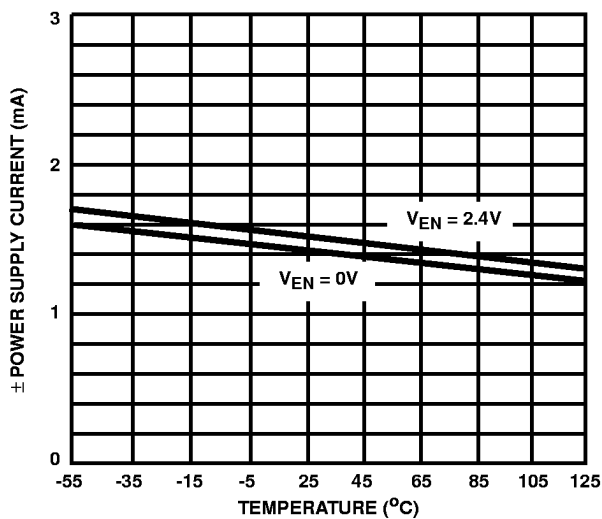

FIGURE 5A. HI-506/HI-507

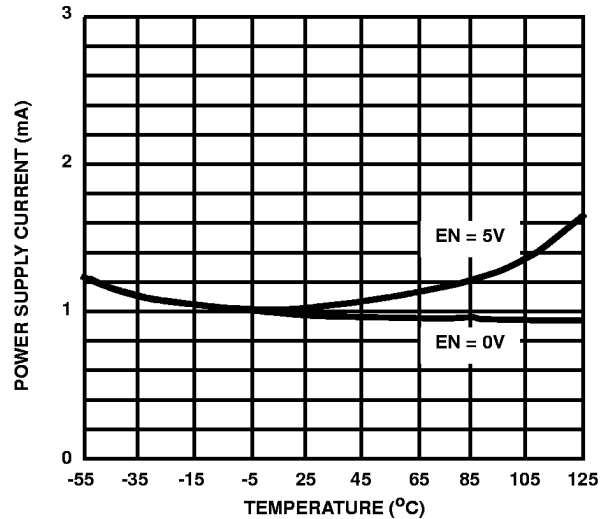

FIGURE 5B. HI-508/HI-509

FIGURE 5. POWER SUPPLY CURRENT vs TEMPERATURE

**Typical Performance Curves**  $T_A = 25^\circ\text{C}$ ,  $V_{\text{SUPPLY}} = \pm 15\text{V}$ ,  $V_{\text{AH}} = 2.4\text{V}$ ,  $V_{\text{AL}} = 0.8\text{V}$ , Unless Otherwise Specified (Continued)

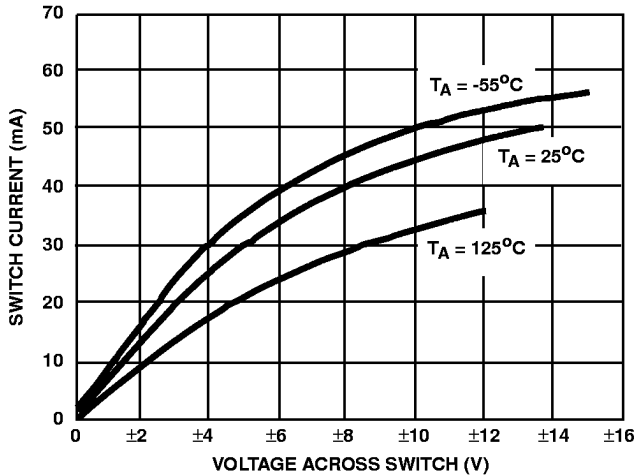

FIGURE 6A. ON CHANNEL CURRENT vs VOLTAGE

FIGURE 6. ON CHANNEL CURRENT vs VOLTAGE

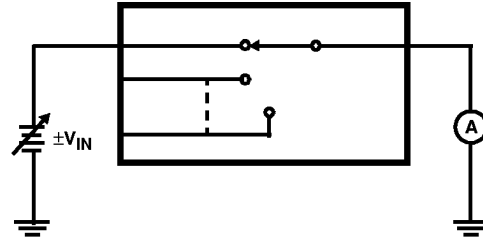

FIGURE 6B. TEST CIRCUIT

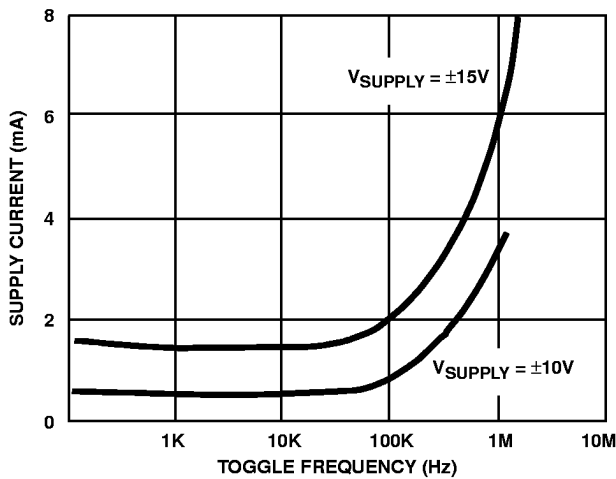

FIGURE 7A. SUPPLY CURRENT vs TOGGLE FREQUENCY

FIGURE 7. SUPPLY CURRENT

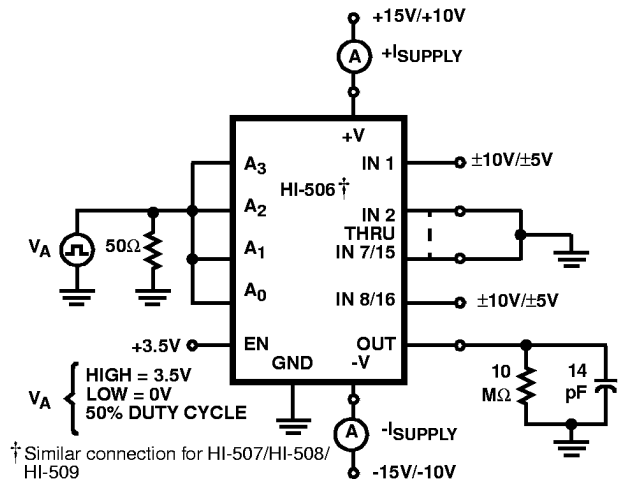

FIGURE 7B. TEST CIRCUIT

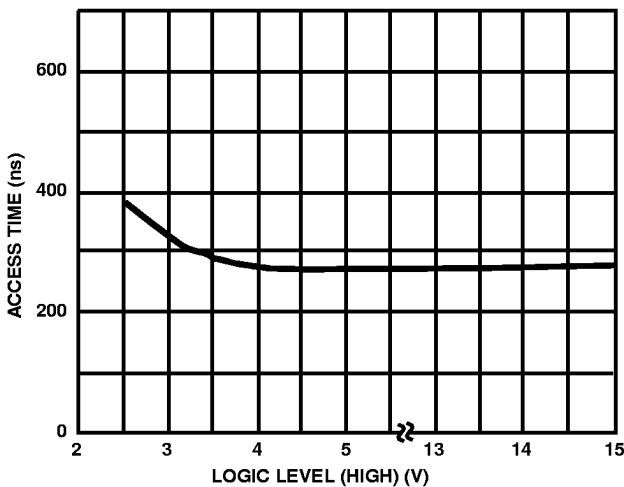

FIGURE 8A. ACCESS TIME vs LOGIC LEVEL (HIGH)

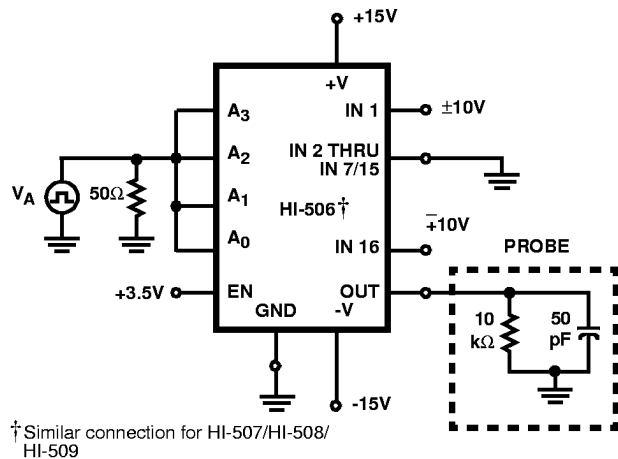

FIGURE 8B. TEST CIRCUIT

Switching Waveforms

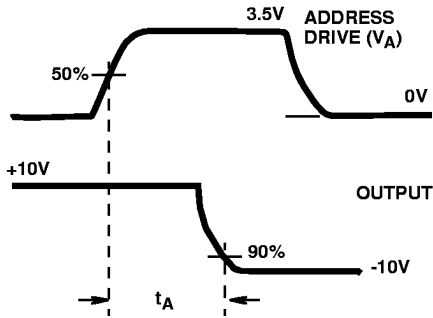

FIGURE 8C. WAVEFORMS

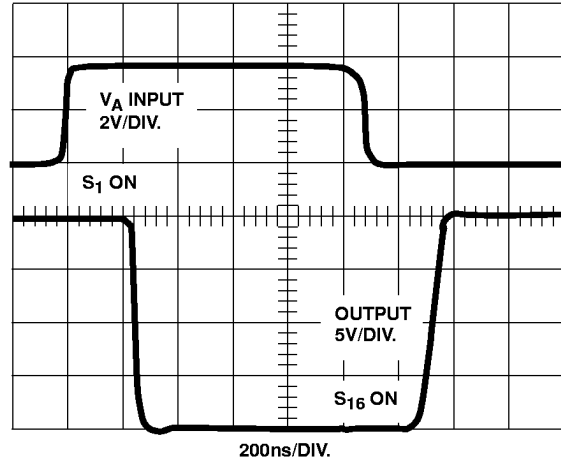
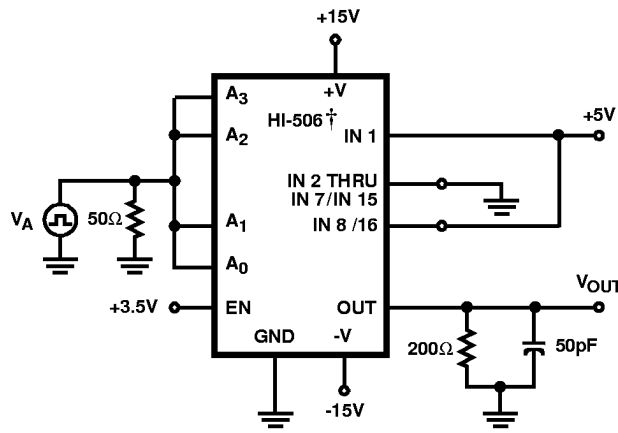

FIGURE 8D. ACCESS TIME

FIGURE 8. ACCESS TIME



† Similar connection for HI-507/HI-508/HI-509

FIGURE 9A. TEST CIRCUIT

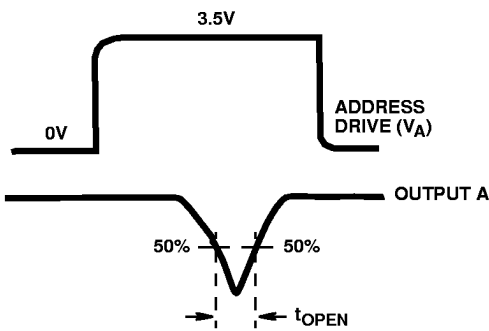

FIGURE 9B. WAVEFORMS

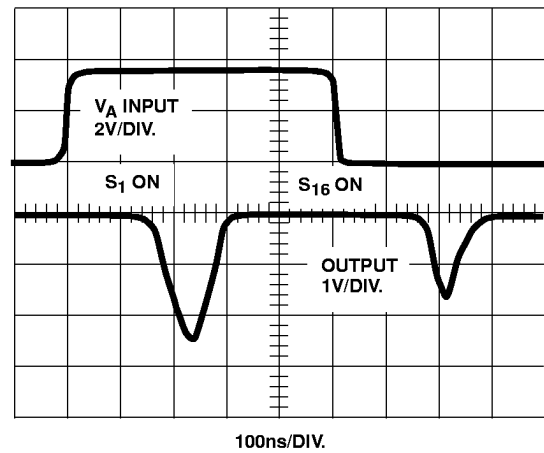
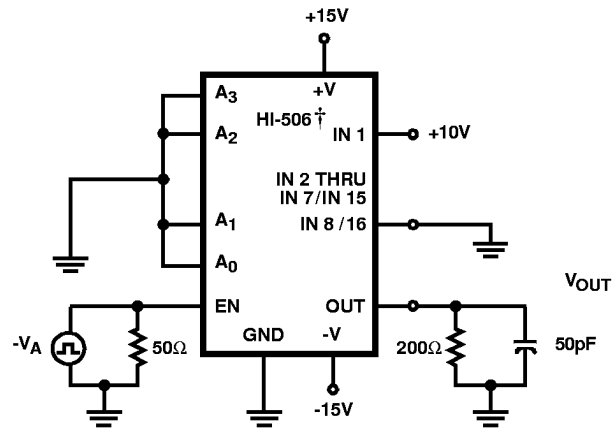

FIGURE 9C. BREAK-BEFORE-MAKE DELAY ( $t_{OPEN}$ )

FIGURE 9. BREAK-BEFORE-MAKE DELAY ( $t_{OPEN}$ )

Switching Waveforms (Continued)



† Similar connection for HI-507/HI-508/HI-509

FIGURE 10A. TEST CIRCUIT

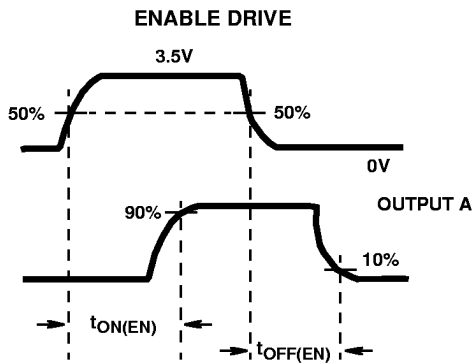

FIGURE 10B. WAVEFORMS

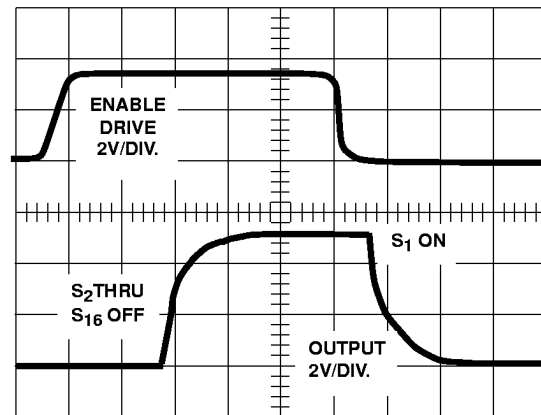

FIGURE 10C. ENABLE DELAY  $t_{ON(EN)}$ ,  $t_{OFF(EN)}$

FIGURE 10. ENABLE DELAY

# HI-506, HI-507, HI-508, HI-509

## Truth Tables

HI-506

A <sub>3</sub>	A <sub>2</sub>	A <sub>1</sub>	A <sub>0</sub>	EN	"ON" CHANNEL
X	X	X	X	L	None
L	L	L	L	H	1
L	L	L	H	H	2
L	L	H	L	H	3
L	L	H	H	H	4
L	H	L	L	H	5
L	H	L	H	H	6
L	H	H	L	H	7
L	H	H	H	H	8
H	L	L	L	H	9
H	L	L	H	H	10
H	L	H	L	H	11
H	L	H	H	H	12
H	H	L	L	H	13
H	H	L	H	H	14
H	H	H	L	H	15
H	H	H	H	H	16

HI-508

A <sub>2</sub>	A <sub>1</sub>	A <sub>0</sub>	EN	"ON" CHANNEL
X	X	X	L	None
L	L	L	H	1
L	L	H	H	2
L	H	L	H	3
L	H	H	H	4
H	L	L	H	5
H	L	H	H	6
H	H	L	H	7
H	H	H	H	8

HI-509

A <sub>1</sub>	A <sub>0</sub>	EN	"ON" CHANNEL PAIR
X	X	L	None
L	L	H	1
L	H	H	2
H	L	H	3
H	H	H	4

HI-507

A <sub>2</sub>	A <sub>1</sub>	A <sub>0</sub>	EN	"ON" CHANNEL
X	X	X	L	None
L	L	L	H	1
L	L	H	H	2
L	H	L	H	3
L	H	H	H	4
H	L	L	H	5
H	L	H	H	6
H	H	L	H	7
H	H	H	H	8

# HI-506, HI-507, HI-508, HI-509

## Die Characteristics

### DIE DIMENSIONS:

129 mils x 82 mils

### METALLIZATION:

Type: CuAl

Thickness:  $16\text{k}\text{\AA} \pm 2\text{k}\text{\AA}$

### SUBSTRATE POTENTIAL (NOTE):

$-V_{\text{SUPPLY}}$

### PASSIVATION:

Type: Nitride/Silox

Nitride Thickness:  $3.5\text{k}\text{\AA} \pm 1\text{k}\text{\AA}$

Silox Thickness:  $12\text{k}\text{\AA} \pm 2\text{k}\text{\AA}$

NOTE: The substrate appears resistive to the  $-V_{\text{SUPPLY}}$  terminal, therefore it may be left floating (Insulating Die Mount) or it may be mounted on a conductor at  $-V_{\text{SUPPLY}}$  potential.

### WORST CASE CURRENT DENSITY:

$1.4 \times 10^5 \text{ A/cm}^2$

### TRANSISTOR COUNT:

421

### PROCESS:

CMOS-DI

## Metallization Mask Layout

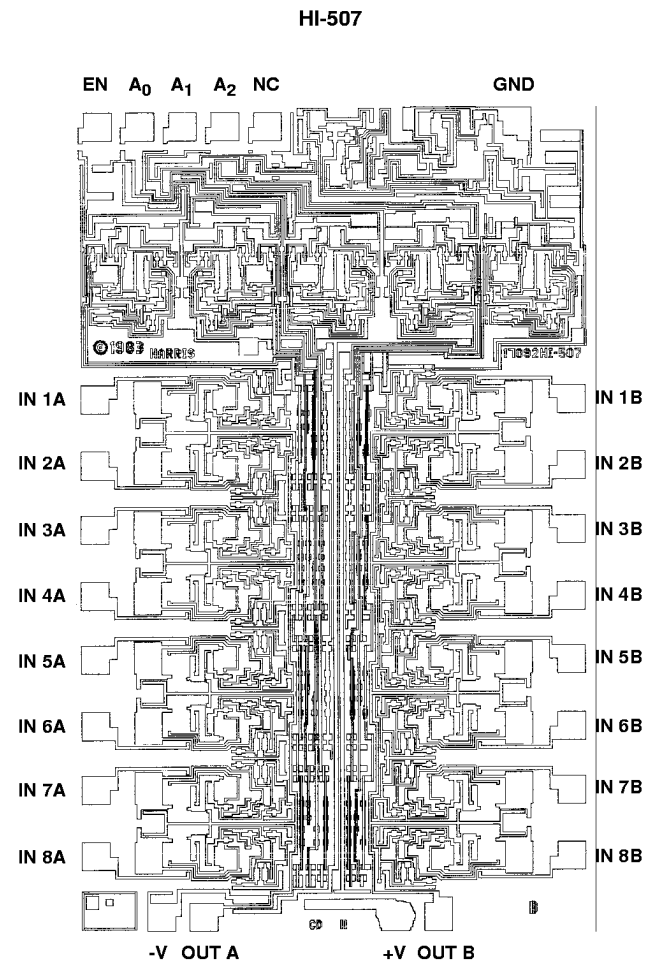
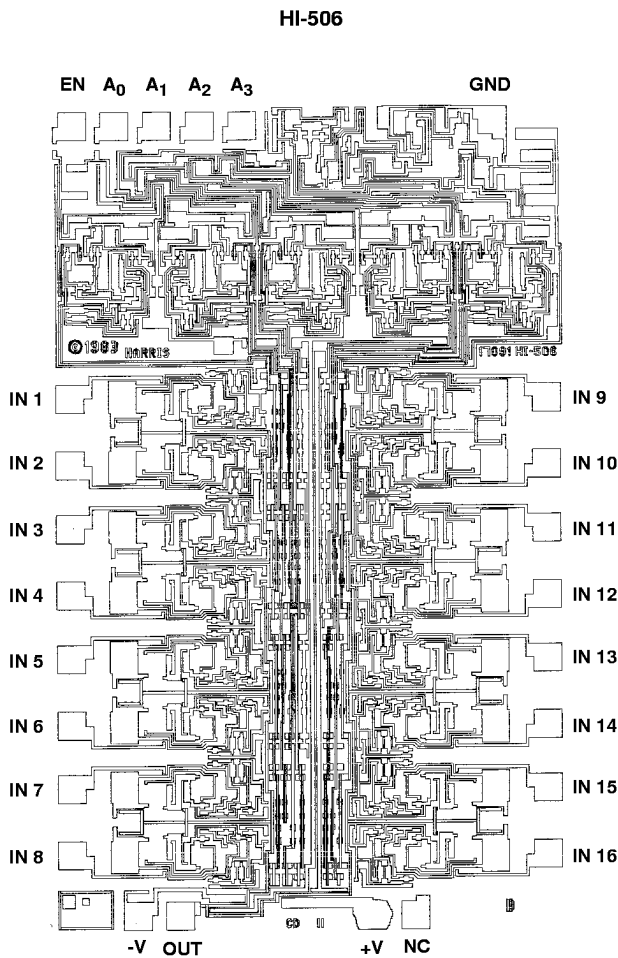

NOTE: Pad numbers correspond to DIP pin numbers only.

# HI-506, HI-507, HI-508, HI-509

## Die Characteristics

### DIE DIMENSIONS:

81.9 mils x 90.2 mils

### METALLIZATION:

Type: CuAl

Thickness:  $16\text{k}\text{\AA} \pm 2\text{k}\text{\AA}$

### SUBSTRATE POTENTIAL (NOTE):

$-V_{\text{SUPPLY}}$

### PASSIVATION:

Type: Nitride/Silox

Nitride Thickness:  $3.5\text{k}\text{\AA} \pm 1\text{k}\text{\AA}$

Silox Thickness:  $12\text{k}\text{\AA} \pm 2\text{k}\text{\AA}$

NOTE: The substrate appears resistive to the  $-V_{\text{SUPPLY}}$  terminal, therefore it may be left floating (Insulating Die Mount) or it may be mounted on a conductor at  $-V_{\text{SUPPLY}}$  potential.

### WORST CASE CURRENT DENSITY:

$1.4 \times 10^5 \text{ A/cm}^2$

### TRANSISTOR COUNT:

234

### PROCESS:

CMOS-DI

## Metallization Mask Layout

HI-508

HI-509

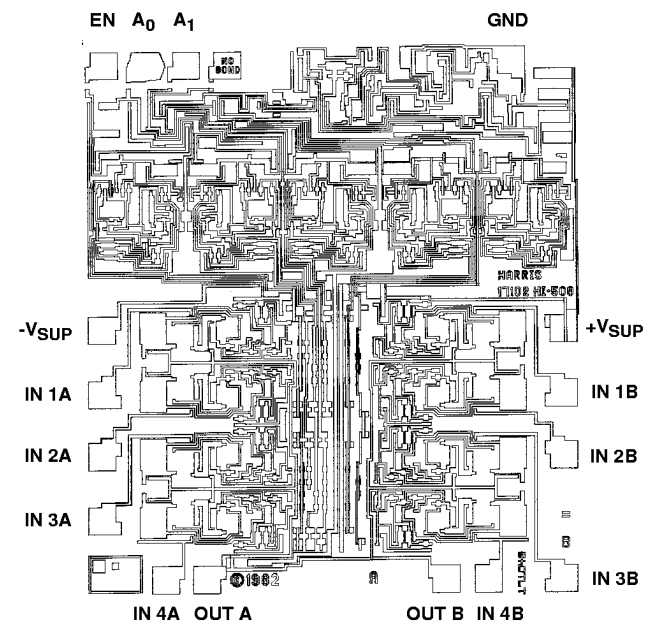
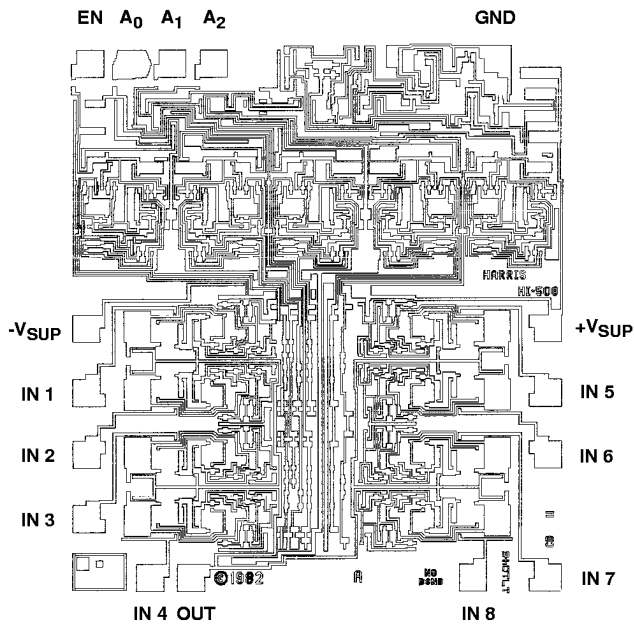

NOTE: Pad numbers correspond to DIP pin numbers only.