

Description

The Si4840/44 is the first analog-tuned digital-display (ATDD) CMOS AM/FM/SW radio receiver IC that integrates the complete receiver function from antenna input to audio output. The Si4840/44 implements Silicon Labs' proven low-IF digital architecture, providing an easy and reliable control interface while eliminating all the manual tuned external components used in traditional solutions. The architecture also provides the industry's leading receiver performance, with excellent sensitivity and selectivity in all supported bands. The Si4840/44 uses a simple potentiometer to provide an analog-tuning interface, and outputs the highly-accurate tuned frequency to a companion MCU / display driver via I²C-compatible, 2-wire control interface. The device supports industry-leading features for band selection, Bass/Treble boost, European EN 55020/22 and U.S. FCC compliance, and advanced audio conditioning for all signal environments to remove pops, clicks, and abrasive static. The device also supports interrupts for valid tuned frequencies and stereo/mono signal quality. These features provide a superb and highly reliable user experience. Like other successful audio products from Silicon Labs, the Si4840/44 offers unmatched integration and PCB space savings with minimum external components and small board area on a single side PCB. The high integration and complete system production test simplifies design-in, increases system quality, and improves manufacturability. The receiver has very low power consumption, runs off two AAA batteries, and delivers the performance benefits of high performance digital radio effect with digital display to the legacy analog-tuned radio market.

Features

- Worldwide FM band support (64–109 MHz)
- Worldwide AM band support (504–1750 kHz)
- SW band support (Si4844 only) (2.3–28.5 MHz)
- Selectable support for all AM/FM/SW regional bands
- 2-wire control interface
- Flexible Mono/Stereo control and programmability
- Digital volume control support
- Excellent real-world performance
- Automatic frequency control (AFC)
- EN55020 compliant
- Minimal BOM components with no manual alignment
- Two AAA batteries with 2.0 to 3.6 V supply voltage
- Wide range of ferrite loop sticks and air loop antennas
- 24-pin SSOP package
- RoHS compliant

Applications

- Table and portable radios
- Stereos
- Mini/micro systems
- Boomboxes
- Clock radios
- Modules
- Entertainment systems
- Toys, lamps, and any application needing an AM/FM radio

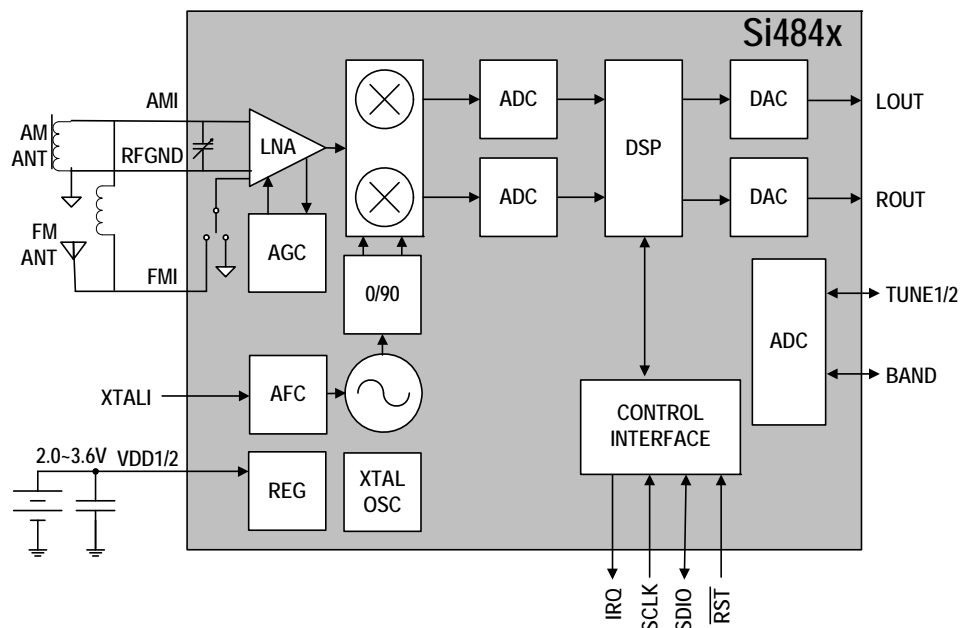

Selected FM Electrical Specifications

Parameter	Symbol	Conditions	Min	Typ	Max	Units
Input Frequency	f_{RF}		64	—	109	MHz
Sensitivity		(S+N)/N = 26 dB	—	2.2	—	μ V EMF
Input IP3			—	105	—	dB μ V EMF
Adjacent Channel Selectivity		\pm 200 kHz	—	50	—	dB
Alternate Channel Selectivity		\pm 400 kHz	—	65	—	dB
Audio Output Voltage			—	80	—	mV _{RMS}
Audio S/N			—	55	—	dB
Audio THD			—	0.1	0.5	%

Selected AM Electrical Specifications

Parameter	Symbol	Conditions	Min	Typ	Max	Units
Input Frequency	f_{RF}	AM	504	—	1750	kHz
		SW	2.3	—	28.5	MHz
Sensitivity		(S+N)/N = 26 dB	—	30	—	μ V EMF
Audio S/N			—	55	—	dB
Audio Output Voltage			—	60	—	mV _{RMS}
Audio THD			—	0.1	0.5	%
Antenna Inductance			180	—	450	μ H

Package Information

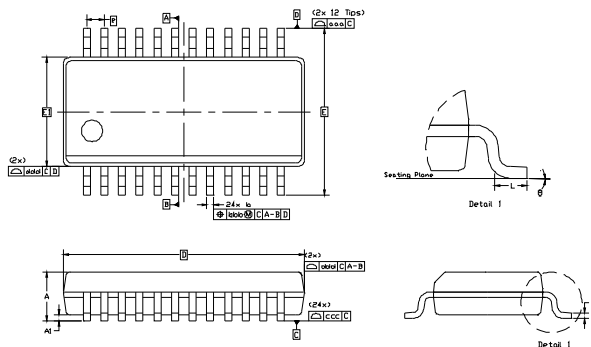

Table 1. Package Dimensions

Dimension	Min	Nom	Max	Dimension	Min	Nom	Max
A	—	—	1.75	e	0.635 BSC		
A1	0.10	—	0.25	L	0.40	—	1.27
b	0.20	—	0.30	θ	0°	—	8°
c	0.10	—	0.25	aaa	0.20		
D	8.65 BSC			bbb	0.18		
E	6.00 BSC			ccc	0.10		
E1	3.90 BSC			ddd	0.10		

Notes:

- All dimensions shown are in millimeters (mm) unless otherwise noted.
- Dimensioning and Tolerancing per ANSI Y14.5M-1994.
- This drawing conforms to the JEDEC Solid State Outline MO-137, Variation AE.
- Recommended card reflow profile is per the JEDEC/IPC J-STD-020 specification for Small Body Components.

Pin Assignments

