

### Single-Chip USB to UART Data Transfer

- Integrated USB transceiver; no external resistors required
- Integrated clock; no external crystal required
- Integrated 1024-Byte One-Time Programmable ROM for customizable product information
- On-chip power-on reset circuit
- On-chip voltage regulator: 3.45 V output

### USB Function Controller

- USB Specification 2.0 compliant; full-speed (12 Mbps)
- USB suspend states supported via SUSPEND and SUSPEND pins

### Asynchronous Serial Data BUS (UART)

- All handshaking and modem interface signals
- Data formats supported:
  - Data bits: 5, 6, 7, and 8
  - Stop bits: 1, 1.5, and 2
  - Parity: odd, even, mark, space, no parity
- Baud rates: 300 bps to 2 Mbits
- 576 Byte receive buffer; 576 byte transmit buffer
- Hardware or X-On/X-Off handshaking supported
- Four GPIO signals for status and control
- Configurable I/O (1.8 V to  $V_{DD}$ ) using  $V_{IO}$  pin
- Configurable I/O ( $V_{DD}$  to 5 V) using external pull-up
- RS-485 mode with bus transceiver control

### Virtual COM Port Device Drivers

- Works with Existing COM Port PC Applications
- Royalty-Free Distribution License
- Windows 7<sup>®</sup>/Vista<sup>®</sup>/XP<sup>®</sup>/Server 2003<sup>®</sup>/2000<sup>®</sup>
- Mac<sup>®</sup> OS-X
- Linux<sup>®</sup>

### USBXpress™ Direct Driver Support

- Royalty-Free Distribution License
- Windows Vista/XP/Server 2003/2000
- Windows CE<sup>®</sup> 6.0, 5.0, and 4.2

### Example Applications

- Upgrade of RS-232 legacy devices to USB
- Upgrade of RS-485 legacy devices to USB
- Cellular phone USB interface cable
- PDA USB interface cable
- USB to RS-232 serial adapter

### Supply Voltage

- Self-powered: 3.0 to 3.6 V
- USB bus powered: 4.0 to 5.25 V
- I/O voltage: 1.8 V to  $V_{DD}$

### Package

- RoHS-compliant 24-pin QFN (4x4 mm)

### Ordering Part Number

- CP2104-F03-GM

Temperature Range: -40 to +85 °C

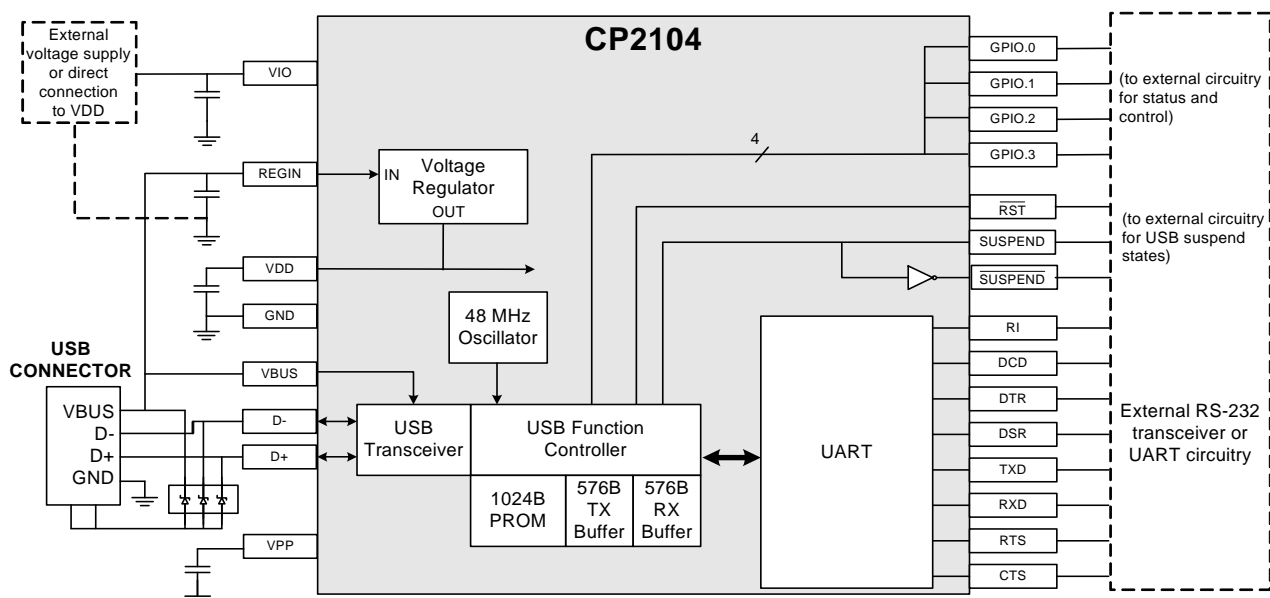

### Selected Electrical Specifications

-40 to +85 °C unless otherwise specified.

Parameter	Conditions	Min	Typ	Max	Units
Input Voltage Range (REGIN)		3.0	—	5.25	V
Regulator Output Voltage	Output Current = 1 to 100 mA*	3.3	3.45	3.6	V
VBUS Detection Input Threshold		2.5	—	—	V
Bias Current		—	—	120	μA

\*Note: The maximum regulator supply current is 100 mA. This includes the supply current of the CP2104.

### Package Information

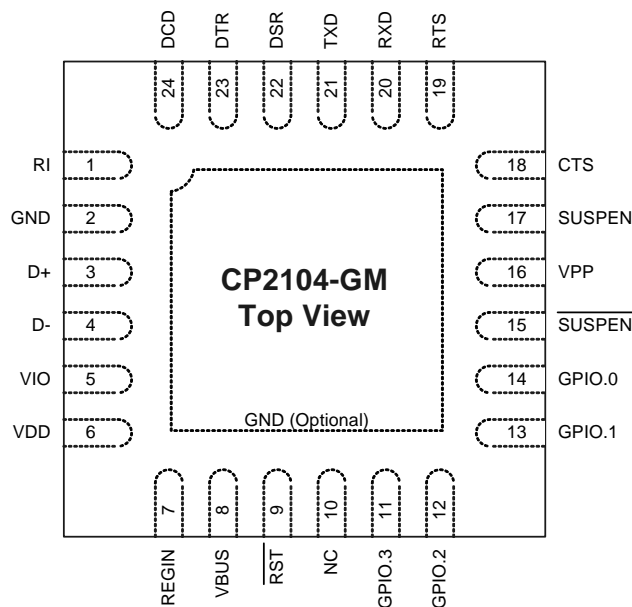

QFN-24 Pinout Diagram (Top View)

### CP2104EK Evaluation Kit

The CP2104EK allows a complete evaluation and customization of the CP2104 USB-to-UART bridge including all GPIO functions, flow control, RS485 transceiver control and transmit and receive LEDs.

- Includes Windows, Mac, and Linux drivers
- USB cable and serial cable
- CD ROM with complete documentation

