

10 9 8 7 6 5 4 3 2 1

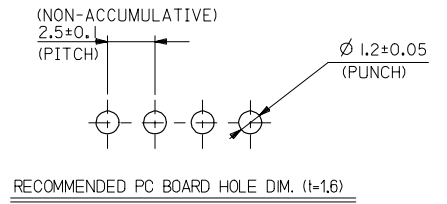

NOTES:  
I ( ) : REFERENCE

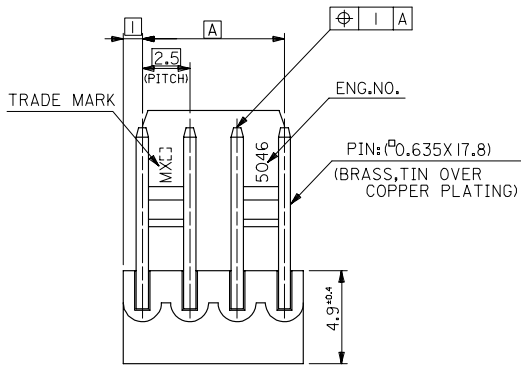
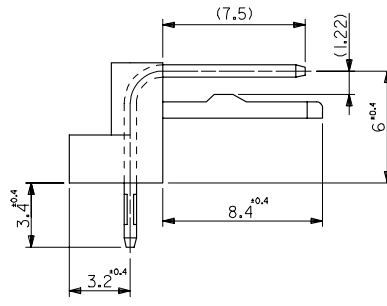
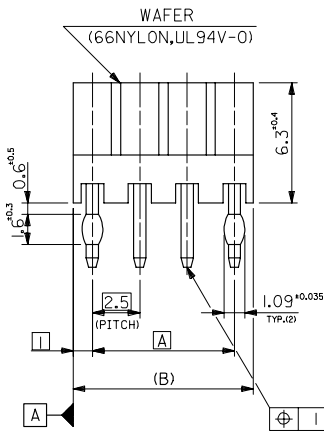

|     |     |            |           |      |
|-----|-----|------------|-----------|------|
| 9.5 | 7.5 | 39-31-1045 | 5046-04AX | 4    |
| (B) | A   | EDP NO.    | ENG.NO.   | CKT. |

|                                                                                                                  |                                       |       |                             |  |                                                                                                                               |  |                                  |  |                        |  |
|------------------------------------------------------------------------------------------------------------------|---------------------------------------|-------|-----------------------------|--|-------------------------------------------------------------------------------------------------------------------------------|--|----------------------------------|--|------------------------|--|
| REVISED<br>EC NO: J2008-0883<br>DRAWN: HABEI 2007/09/25<br>CHKD: THIRUYANA 2007/09/26<br>APPR: NIKITA 2007/09/26 | GENERAL TOLERANCES (UNLESS SPECIFIED) |       | DIMENSION STYLE<br>MM ONLY  |  | SCALE<br>5:1                                                                                                                  |  | DESIGN UNITS<br>METRIC           |  | THIRD ANGLE PROJECTION |  |
|                                                                                                                  | 10 UNDER                              | ±0.2  | DRAWN BY<br>T. TAKAHASHI    |  | DATE<br>'89/03/08                                                                                                             |  | KK2.5 RIGHT ANGLE<br>WAFER ASS'Y |  |                        |  |
|                                                                                                                  | 10 OVER 30 UNDER                      | ±0.25 | CHECKED BY<br>T. YAMAGUCHI  |  | DATE<br>'99/04/20                                                                                                             |  |                                  |  |                        |  |
|                                                                                                                  | 30 OVER                               | ±0.3  | APPROVED BY<br>M. FUKUSHIMA |  | DATE<br>'99/04/20                                                                                                             |  | MOLEX INCORPORATED               |  |                        |  |
| ANGULAR                                                                                                          |                                       | ±3 °  | MATERIAL NO.                |  | DOCUMENT NO.                                                                                                                  |  | SD-5046-001                      |  | SHEET NO.<br>1 OF 1    |  |
| DRAFT WHERE APPLICABLE MUST REMAIN WITHIN DIMENSIONS                                                             |                                       |       | SEE TABLE                   |  | THIS DRAWING CONTAINS INFORMATION THAT IS PROPRIETARY TO MOLEX INCORPORATED AND SHOULD NOT BE USED WITHOUT WRITTEN PERMISSION |  |                                  |  |                        |  |