



**TS971
TS972
TS974**

OUTPUT RAIL TO RAIL VERY LOW NOISE OPERATIONAL AMPLIFIERS

- RAIL TO RAIL **OUTPUT VOLTAGE SWING** ($\pm 2.4V$ @ $V_{CC} = \pm 2.5V$)
- VERY LOW NOISE LEVEL : $4nV/\sqrt{Hz}$
- ULTRA LOW DISTORTION : **0.003%**
- HIGH DYNAMIC FEATURES (**12MHz, 4V/ μs**)
- OPERATING RANGE : **2.7V to 12V**
- ESD PROTECTION (**2kV**)
- LATCH-UP IMMUNITY
- AVAILABLE IN **SOT23-5 MICROPACKAGE**

DESCRIPTION

The TS97x family operational amplifiers is able to operate with voltages as low as $\pm 1.35V$ and featuring output Rail to Rail signal swing. The TS97x boasts characteristics that make them particularly well suited for portable and battery-supplied equipment. Very low noise and low distortion characteristics make them ideal for audio pre-amplification.

The TS971 is housed in the space-saving 5 pins SOT23 package which simplifies the board design because of the ability to be placed everywhere (outside dimensions are 2.8mm x 2.9mm)

APPLICATIONS

- Portable equipments (CD players, PDA)
- Portable communications (cell phones, pagers)
- Instrumentation & sensing
- Professional audio circuits

ORDER CODES

Part Number	Temperature Range	Package				SOT23 Marking
		N	D	P	L	
TS971I	-40, +125°C		•		•	K120
TS972I	-40, +125°C	•	•	•		
TS974I	-40, +125°C	•	•	•		

N = Dual in Line Package (DIP)

D = Small Outline Package (SO) - also available in Tape & Reel

P = Thin Shrink Small Outline Package (TSSOP) - only available in Tape & Reel (PT)

L = Tiny Package (SOT23-5) - only available in Tape & Reel (LT)

PIN CONNECTIONS (top view)

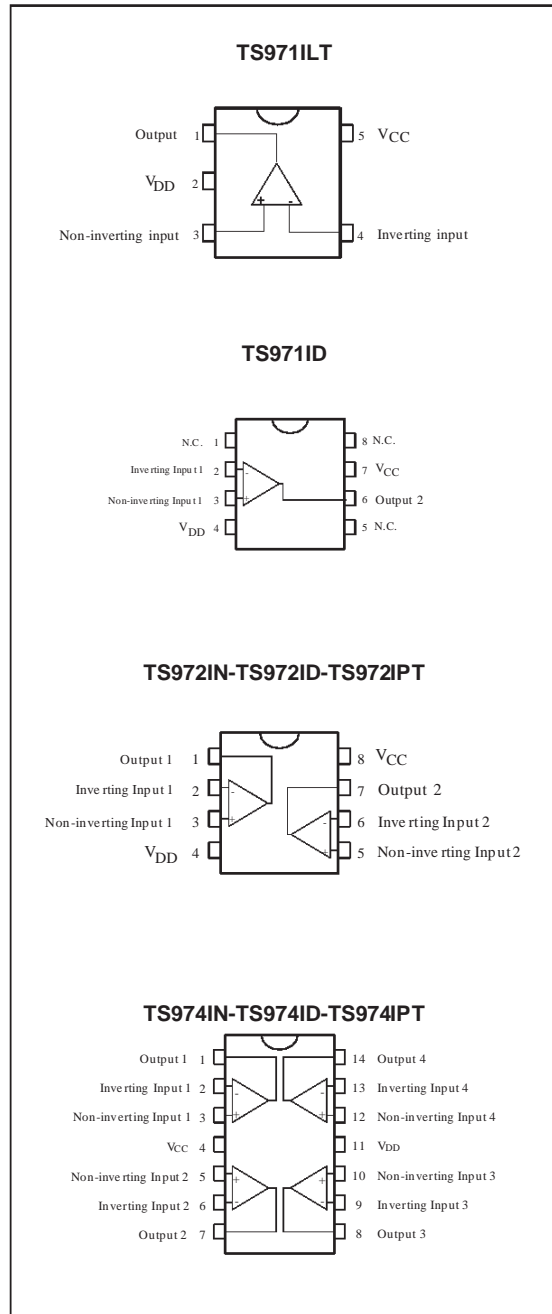

ABSOLUTE MAXIMUM RATINGS

Symbol	Parameter	Value	Unit
V _{CC}	Supply Voltage - note 1	12	V
V _{id}	Differential Input Voltage - note 2	±V _{CC}	V
V _{in}	Input Voltage Range - note 3	-0.3 to 12.3	V
T _{oper}	Operating Free Air Temperature Range	-40 to +125	°C
T _{stg}	Storage Temperature Range	-65 to +150	°C
T _j	Maximum Junction Temperature	150	°C
R _{thjc}	Thermal Resistance Junction to Case - note 4 SOT23-5 SO8 SO14 TSSOP8 TSSOP14	81 28 22 26 21	°C/W
R _{thja}	Thermal Resistance Junction to Ambient	256	°C/W
ESD	Human Body Model	2	kV
	Lead Temperature (soldering, 10sec)	260	°C

- Notes:**
1. All voltages values, except differential voltage are with respect to network ground terminal.
 2. Differential voltages are non-inverting input terminal with respect to the inverting input terminal.
 3. The magnitude of input and output voltages must never exceed V_{CC} +0.3V.
 4. Short-circuits can cause excessive heating and destructive dissipation.

OPERATING CONDITIONS

Symbol	Parameter	Value	Unit
V _{CC}	Supply Voltage Range	2.7 to 12	V
V _{icm}	Common Mode Input Voltage Range	V _{DD} + 1.15 to V _{CC} - 1.15	V

ELECTRICAL CHARACTERISTICS $V_{CC} = 2.5V$, $V_{DD} = -2.5V$, $T_{amb} = 25^{\circ}C$ (unless otherwise specified)

Symbol	Parameter	Min.	Typ.	Max.	Unit
V_{io}	Input Offset Voltage $T_{min.} < T_{amb} < T_{max.}$		1	5 7	mV
DV_{io}	Input Offset Voltage Drift $V_{icm} = 0V$, $V_o = 0V$		5		$\mu V/^{\circ}C$
I_{io}	Input Offset Current $V_{icm} = 0V$, $V_o = 0V$		10	150	nA
I_{ib}	Input Bias Current $V_{icm} = 0V$, $V_o = 0V$ $T_{min.} < T_{amb} < T_{max.}$		200 200	750 1000	nA
V_{icm}	Common Mode Input Voltage Range	-1.35	± 1.5	1.35	V
CMR	Common Mode Rejection Ratio $V_{icm} = \pm 1.35V$	60	85		dB
SVR	Supply Voltage Rejection Ratio $V_{CC} = \pm 2V$ to $\pm 3V$	60	70		dB
A_{vd}	Large Signal Voltage Gain $R_L = 2k\Omega$	70	80		dB
V_{OH}	High Level Output Voltage $R_L = 2k\Omega$	2	2.4		V
V_{OL}	Low Level Output Voltage $R_L = 2k\Omega$		-2.4	-2	V
I_{source}	Output Source Current		1.5		mA
I_{sink}	Output Sink Current		100		mA
I_{CC}	Supply Current Unity gain - no load		2	2.8	mA
GBP	Gain Bandwidth Product $f = 100kHz$ $R_L = 2k\Omega$, $C_L = 100pF$	8.5	12		MHz
SR	Slew Rate $A_V = 1$, $V_{in} = \pm 1V$	2.8	4		V/ μs
ϕ_m	Phase Margin at Unity Gain $R_L = 2k\Omega$, $C_L = 100pF$		60		Degrees
Gm	Gain Margin $R_L = 2k\Omega$, $C_L = 100pF$		10		dB
e_n	Equivalent Input Noise Voltage $f = 100kHz$		4		$\frac{nV}{\sqrt{Hz}}$
THD	Total Harmonic Distortion $f = 1kHz$, $A_V = -1$ $R_L = 10k\Omega$		0.003		%

INPUT OFFSET VOLTAGE DISTRIBUTION

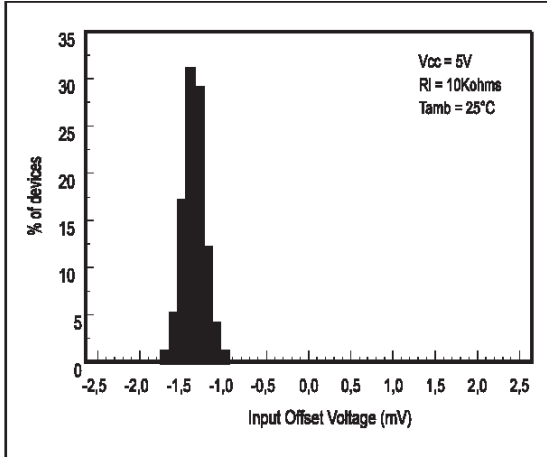

VOLTAGE GAIN & PHASE vs FREQUENCY

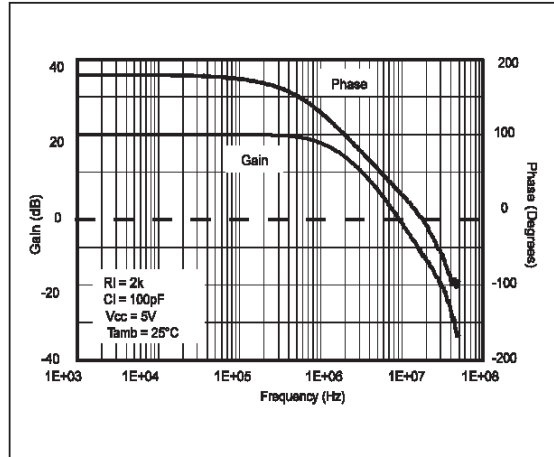

VOLTAGE GAIN & PHASE vs FREQUENCY

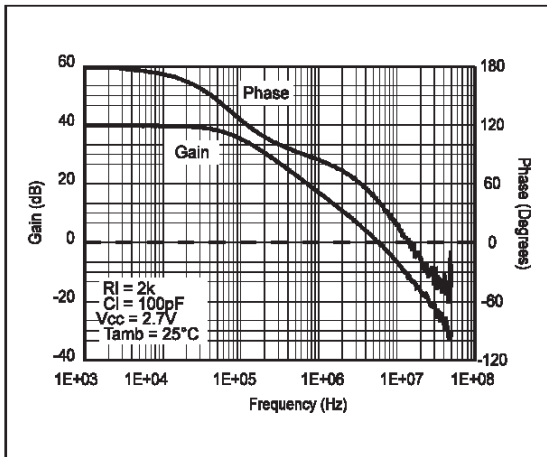

THD vs Vout

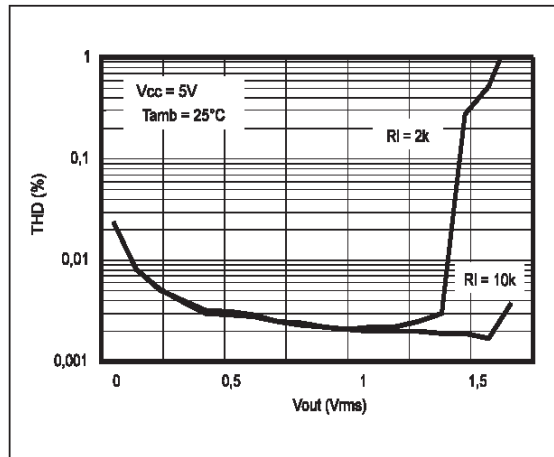

THD vs Vout

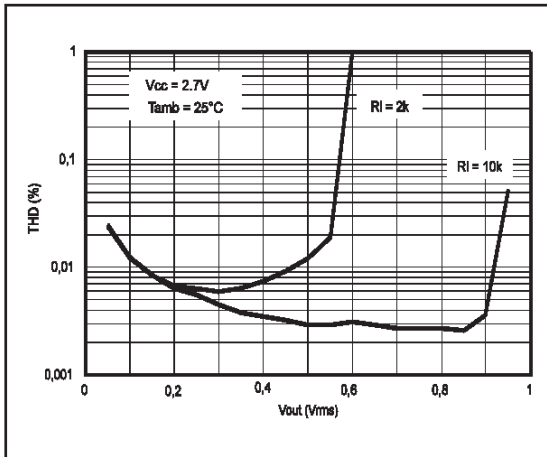

THD vs FREQUENCY

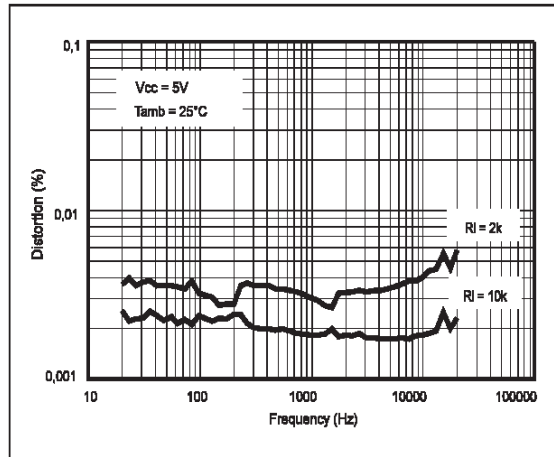

NOISE VOLTAGE vs FREQUENCY

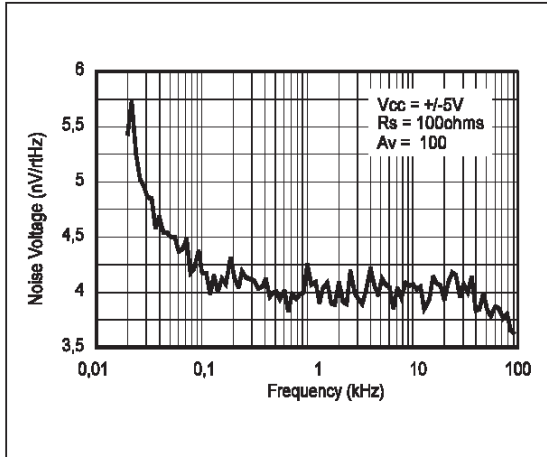

GAIN BANDWIDTH PRODUCT vs Iout

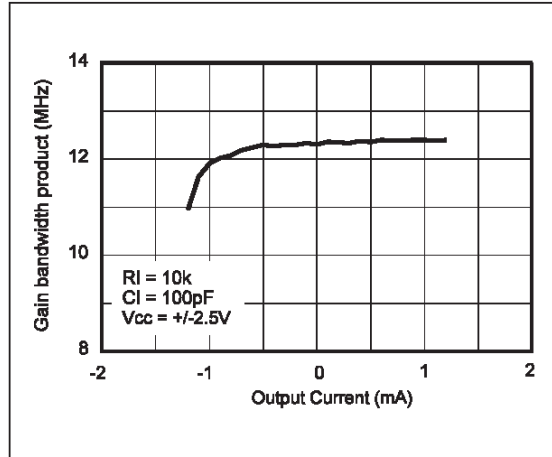

PHASE MARGIN vs Iout

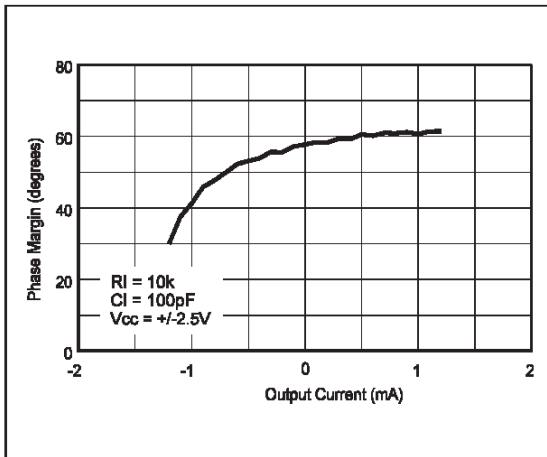

PHASE MARGIN vs VCC

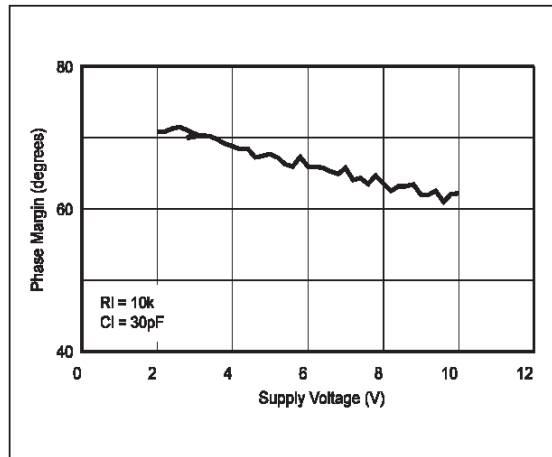

PHASE MARGIN vs VCC

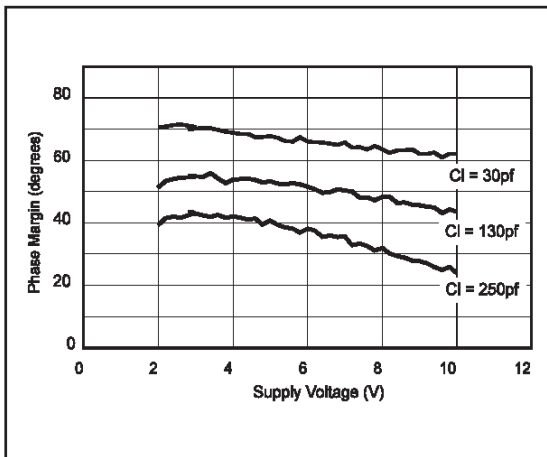

GAIN MARGIN vs VCC

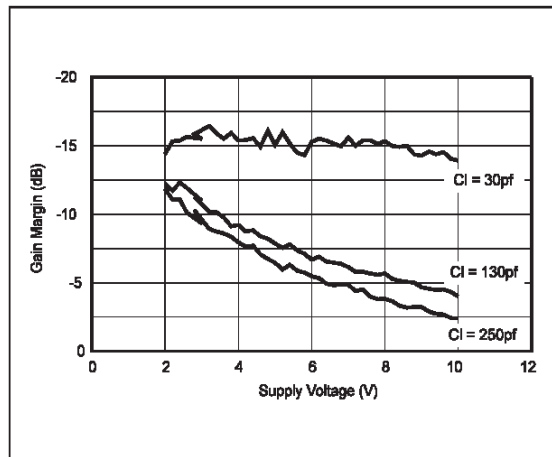

TS971-TS972-TS974

TS972IN

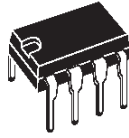

PACKAGE MECHANICAL DATA 8 PINS - PLASTIC DIP

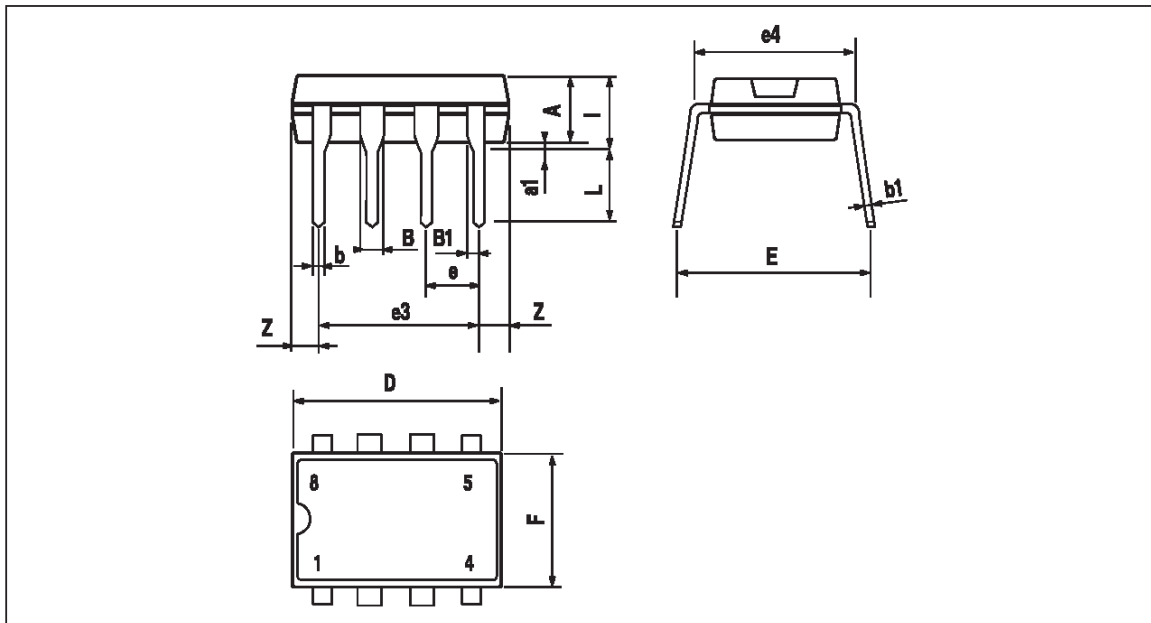

Dimensions	Millimeters			Inches		
	Min.	Typ.	Max.	Min.	Typ.	Max.
A		3.32			0.131	
a1	0.51			0.020		
B	1.15		1.65	0.045		0.065
b	0.356		0.55	0.014		0.022
b1	0.204		0.304	0.008		0.012
D			10.92			0.430
E	7.95		9.75	0.313		0.384
e		2.54			0.100	
e3		7.62			0.300	

TS971ID - TS972ID

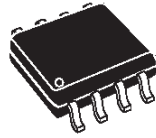

PACKAGE MECHANICAL DATA
8 PINS - PLASTIC MICROPACKAGE (SO)

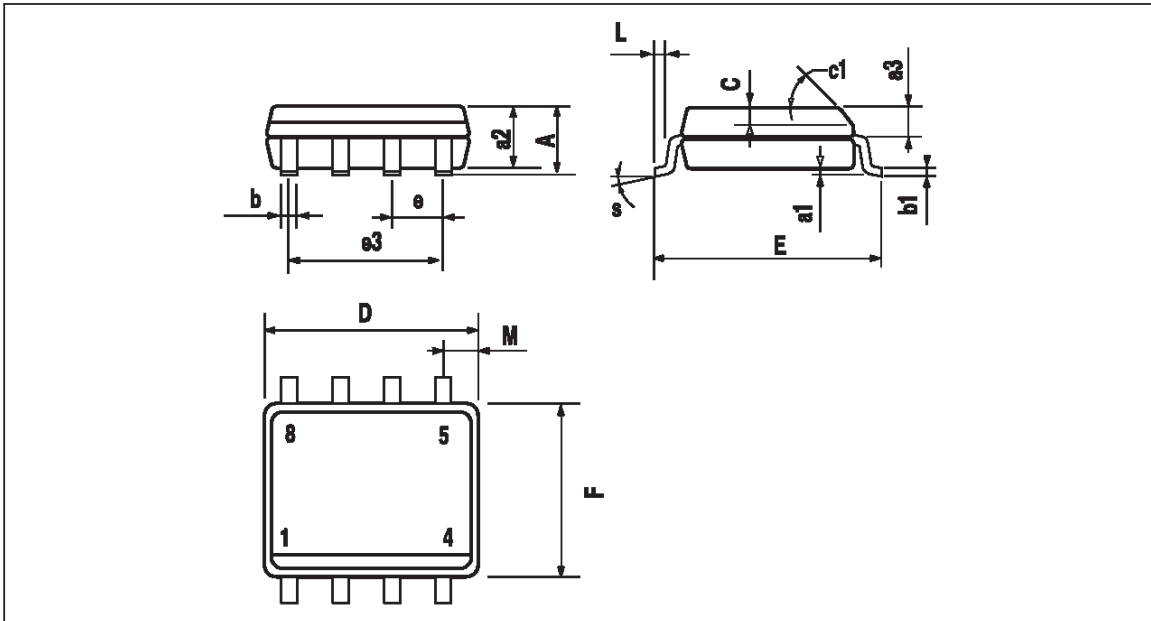

Dimensions	Millimeters			Inches		
	Min.	Typ.	Max.	Min.	Typ.	Max.
A			1.75			0.069
a1*	0.1		0.25	0.004		0.010
a2			1.65			0.065
a3	0.65		0.85	0.026		0.033
b	0.35		0.48	0.014		0.019
b1	0.19		0.25	0.007		0.010
C	0.25		0.5	0.010		0.020
c1	45° (typ.)					
D	4.8		5.0	0.189		0.197
E	5.8		6.2	0.228		0.244
e		1.27			0.050	
e3		3.81			0.150	
F	3.8		4.0	0.150		0.157
L	0.4		1.27	0.016		0.050
M			0.6			0.024
S	8° (max.)					

* coplanarity between all the leads : 0.1mm

TS972IPT

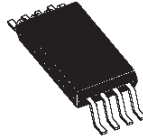

PACKAGE MECHANICAL DATA

8 PINS - THIN SHRINK SMALL OUTLINE PACKAGE (TSSOP)

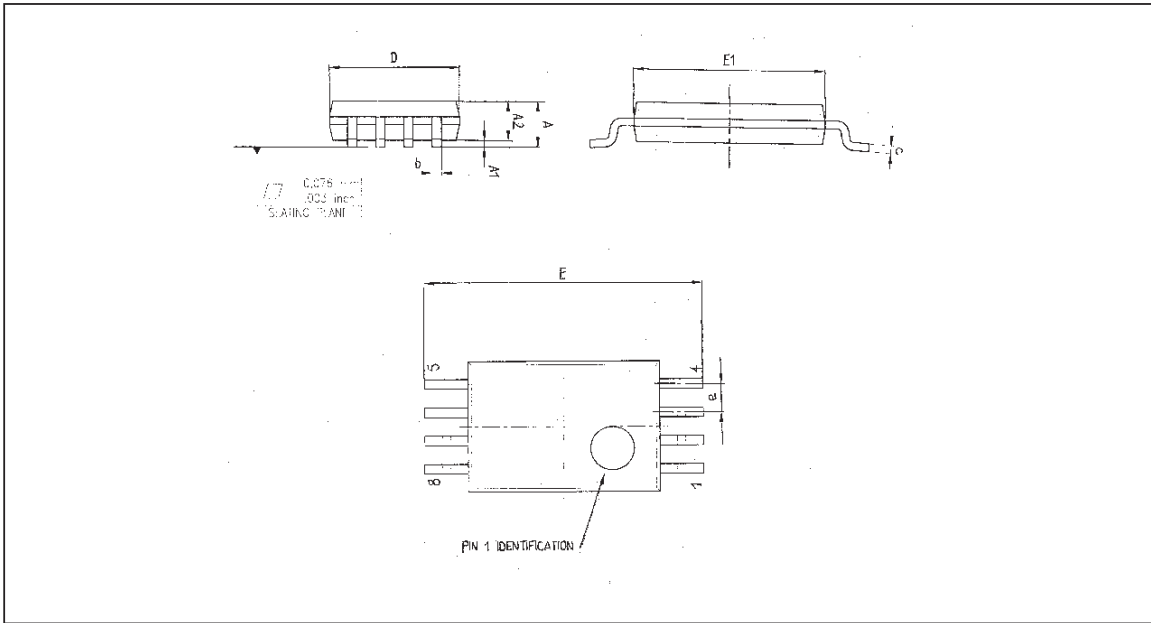

Dim.	Millimeters			Inches		
	Min.	Typ.	Max.	Min.	Typ.	Max.
A			1.20			0.05
A1	0.05		0.15	0.01		0.006
A2	0.80	1.00	1.05	0.031	0.039	0.041
b	0.19		0.30	0.007		0.15
c	0.09		0.20	0.003		0.012
D	2.90	3.00	3.10	0.114	0.118	0.122
E		6.40			0.252	
E1	4.30	4.40	4.50	0.169	0.173	0.177
e		0.65			0.025	
k	0°		8°	0°		8°
l	0.50	0.60	0.75	0.09	0.0236	0.030

TS974IN

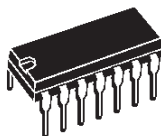

PACKAGE MECHANICAL DATA
14 PINS - PLASTIC DIP

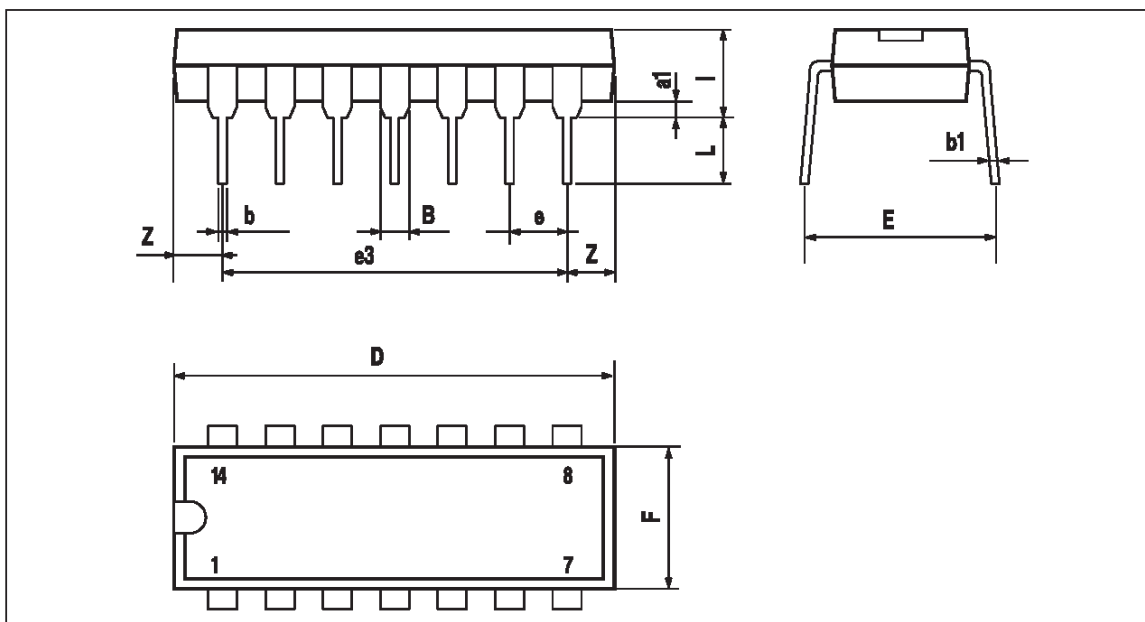

Dim.	Millimeters			Inches		
	Min.	Typ.	Max.	Min.	Typ.	Max.
a1	0.51			0.020		
B	1.39		1.65	0.055		0.065
b		0.5			0.020	
b1		0.25			0.010	
D			20			0.787
E		8.5			0.335	
e		2.54			0.100	
e3		15.24			0.600	

TS971-TS972-TS974

TS974ID

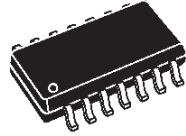

PACKAGE MECHANICAL DATA
14 PINS - PLASTIC MICROPACKAGE (SO)

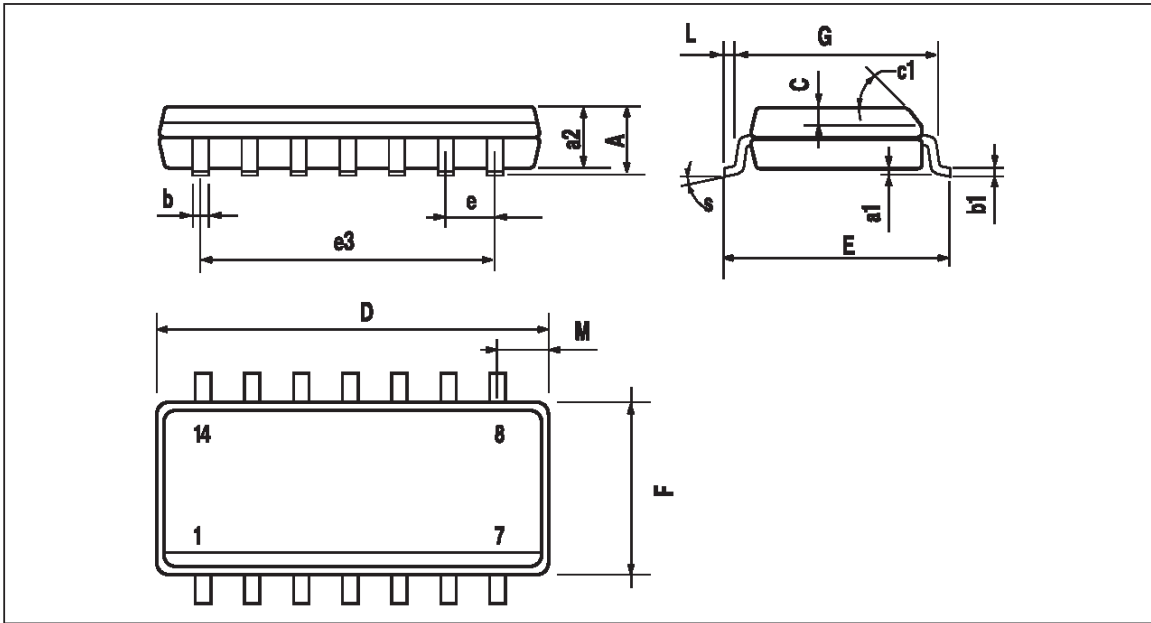

Dim.	Millimeters			Inches		
	Min.	Typ.	Max.	Min.	Typ.	Max.
A			1.75			0.069
a1	0.1		0.2	0.004		0.008
a2			1.6			0.063
b	0.35		0.46	0.014		0.018
b1	0.19		0.25	0.007		0.010
C		0.5			0.020	
c1	45° (typ.)					
D	8.55		8.75	0.336		0.334
E	5.8		6.2	0.228		0.244
e		1.27			0.050	
e3		7.62			0.300	
F	3.8		4.0	0.150		0.157
G	4.6		5.3	0.181		0.208
L	0.5		1.27	0.020		0.050
M			0.68			0.027
S	8° (max.)					

TS974IPT

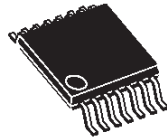

PACKAGE MECHANICAL DATA
14 PINS - THIN SHRINK SMALL OUTLINE PACKAGE (TSSOP)

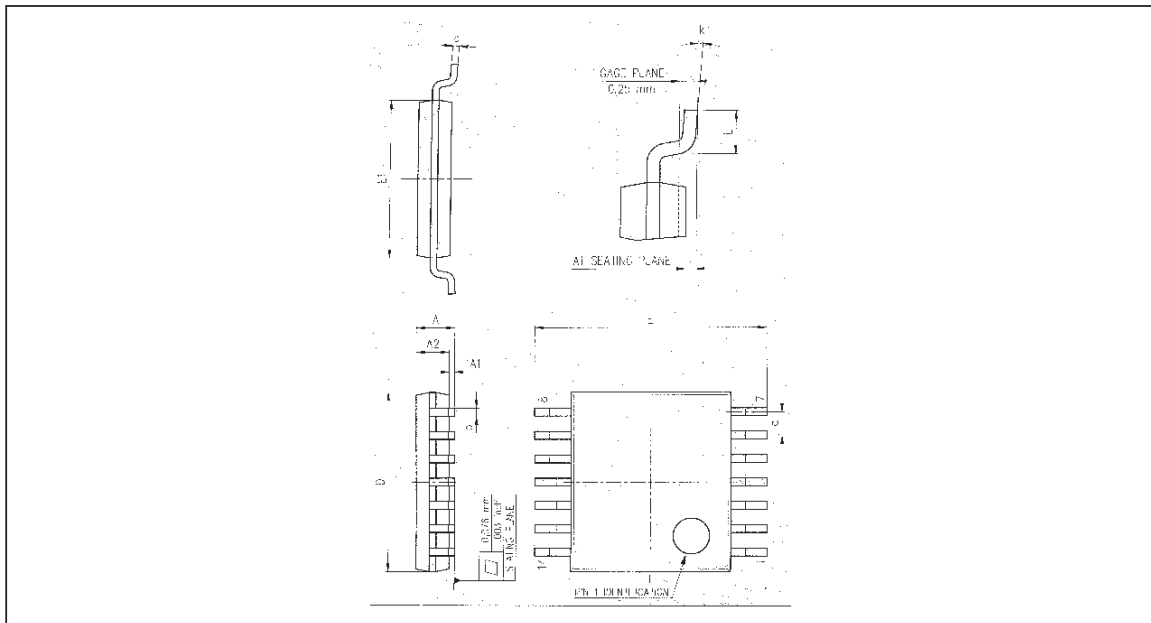

Dim.	Millimeters			Inches		
	Min.	Typ.	Max.	Min.	Typ.	Max.
A			1.20			0.05
A1	0.05		0.15	0.01		0.006
A2	0.80	1.00	1.05	0.031	0.039	0.041
b	0.19		0.30	0.007		0.15
c	0.09		0.20	0.003		0.012
D	4.90	5.00	5.10	0.192	0.196	0.20
E		6.40			0.252	
E1	4.30	4.40	4.50	0.169	0.173	0.177
e		0.65			0.025	
k	0°		8°	0°		8°
l	0.50	0.60	0.75	0.09	0.0236	0.030

TS971-TS972-TS974

TS971ILT

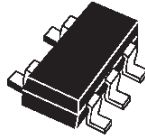

PACKAGE MECHANICAL DATA 5 PINS -TINY PACKAGE (SOT23)

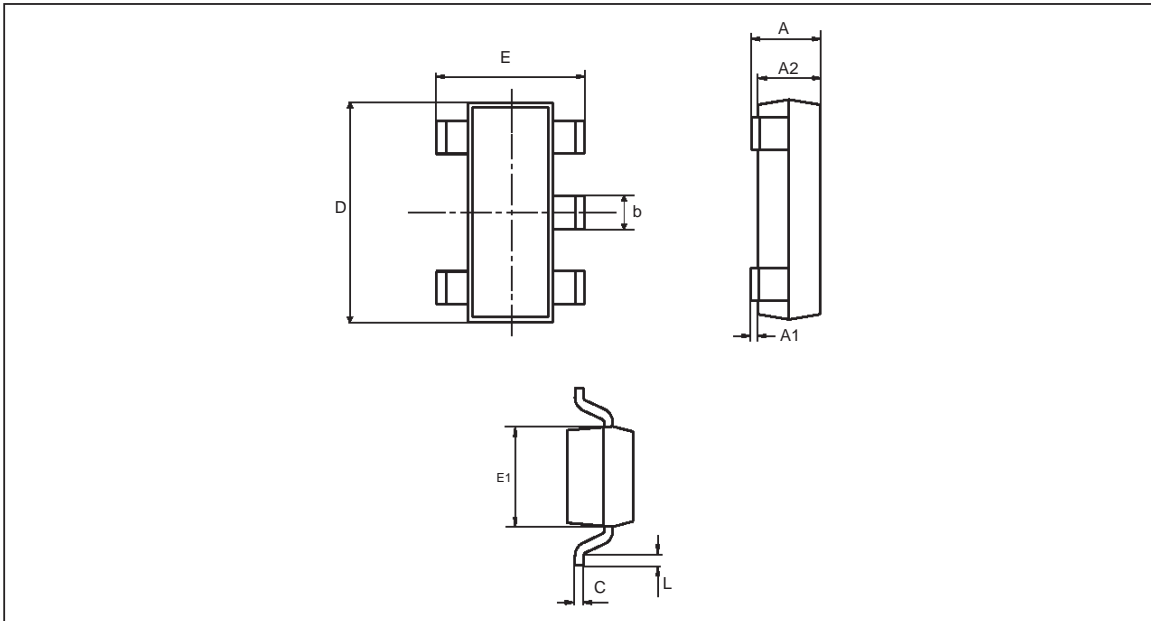

Dim.	Millimeters		Inches	
	Min.	Max.	Min.	Max.
A	0.90	1.45	0.034	0.057
A1	0	0.15		0.006
A2	0.90	1.30	0.034	0.051
b	0.35	0.50	0.013	0.020
C	0.09	0.20	0.003	0.008
D	2.80	3.00	0.110	0.118
E	2.60	3.00	0.102	0.118
E1	1.50	1.75	0.059	0.069
L	0.10	0.60	0.003	0.024

Information furnished is believed to be accurate and reliable. However, STMicroelectronics assumes no responsibility for the consequences of use of such information nor for any infringement of patents or other rights of third parties which may result from its use. No license is granted by implication or otherwise under any patent or patent rights of STMicroelectronics. Specifications mentioned in this publication are subject to change without notice. This publication supersedes and replaces all information previously supplied. STMicroelectronics products are not authorized for use as critical components in life support devices or systems without express written approval of STMicroelectronics.

© The ST logo is a trademark of STMicroelectronics

© 1999 STMicroelectronics – Printed in Italy – All Rights Reserved

STMicroelectronics GROUP OF COMPANIES

Australia - Brazil - China - Finland - France - Germany - Hong Kong - India - Italy - Japan - Malaysia - Malta - Morocco
Singapore - Spain - Sweden - Switzerland - United Kingdom - U.S.A.

© <http://www.st.com>