

M51951A,B/M51952A,B

VOLTAGE DETECTING, SYSTEM RESETTING IC SERIES

DESCRIPTION

M51951A,B/M51952A,B are semiconductor integrated circuits suited for detecting supply voltage and resetting all types of logic circuits such as CPUs.

They include a built-in delay circuit to provide a retardation time (200 μ sec typ.).

They find extensive applications, including circuits for battery checking, level detecting and waveform shaping.

FEATURES

- Few external parts
- Low threshold operating voltage (Supply voltage to keep low-state at low supply voltage
 0.6V (TYP.) at $R_L = 22k\Omega$)
- Wide supply voltage range 2 ~ 17V
- Sudden change in power supply has minimal effect on the ICs
- Wide application range
- SIL package of the same height as DIP (5-pin SIP)
- Extra-small 3-pin package (3-pin FLAT)

APPLICATION

Reset circuit of Pch, Nch, CMOS, microcomputer, CPU and microcomputer, Reset of logic circuit, Battery check circuit, Switching circuit back-up voltage, Level detecting circuit, Waveform shaping circuit, Delay waveform generating circuit, DC-DC converter, Over voltage protection circuit.

RECOMMENDED OPERATING CONDITION

Supply voltage range 2 ~ 17V

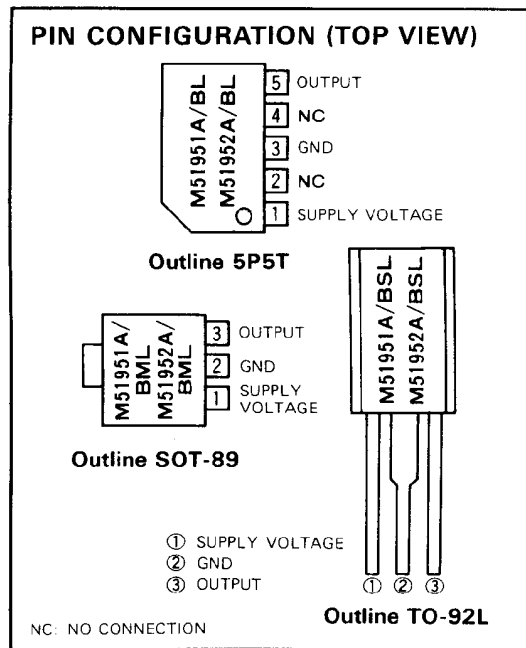

BLOCK DIAGRAM

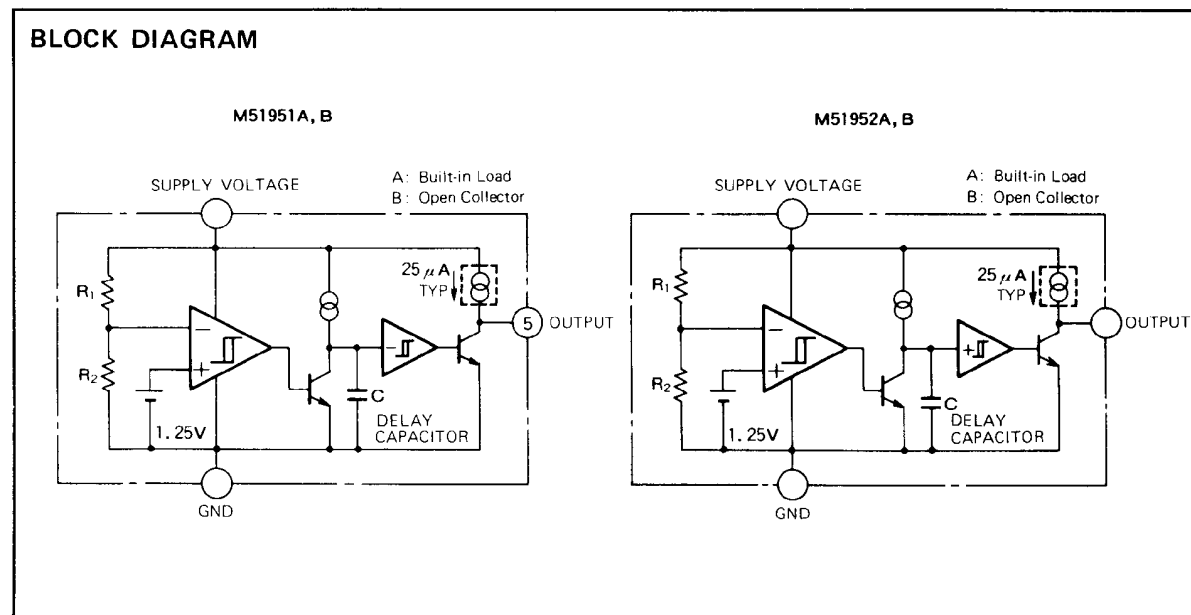

VOLTAGE DETECTING, SYSTEM RESETTING IC SERIES

FUNCTION DIAGRAM

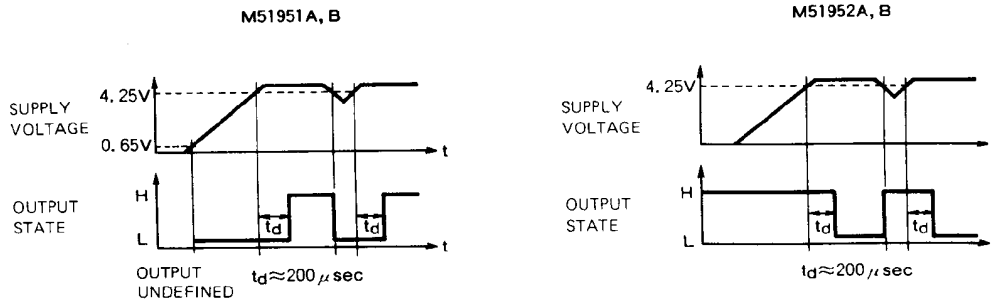

ABSOLUTE MAXIMUM RATINGS ($T_a = 25^\circ\text{C}$, unless otherwise noted)

Symbol	Parameter	Conditions	Ratings	Unit	
V_{CC}	Supply voltage		18	V	
I_{sink}	Output Sink Current		6	mA	
V_O	Output voltage	A Type (Output with constant current load)	V_{CC}	V	
		B Type (Open collector output)	18		
P_d	Power dissipation	5P SIL	450	mW	
		3P SIL	700		
		3P FLAT	500		
K_θ	Thermal Derating	$T_a \geq 25^\circ\text{C}$	5P SIL	4.5	mW/°C
			3P SIL	7	
			3P FLAT	5	
T_{opr}	Operating temperature		$-30 \sim +85$	°C	
T_{stg}	Storage temperature		$-40 \sim +125$	°C	

ELECTRICAL CHARACTERISTICS ($T_a = 25^\circ\text{C}$, unless otherwise noted)

"L" reset type	"H" reset type
M51951A	M51952A
M51951B	M51952B

Symbol	Parameter	Test conditions	Limits			Unit	
			Min	Typ	Max		
V_S	Detecting voltage		4.05	4.25	4.45	V	
ΔV_S	Hysteresis voltage		30	50	80	mV	
$V_S/\Delta T$	Detecting voltage Temperature Coefficient		—	0.01	—	%/°C	
I_{CC}	Circuit Current	Type A $V_{CC} = 5V$	—	450	680	μA	
		Type B $V_{CC} = 5V$	—	420	630		
t_{pd}	Delay Time	$T_a = -30 \sim +85^\circ\text{C}$ (Note)	80	200	500	μs	
V_{sat}	Output Saturation Voltage	L reset type $V_{CC} = 4V, I_{sink} = 4mA$	—	0.2	0.4	V	
		H reset type $V_{CC} = 5V, I_{sink} = 4mA$	—	0.2	0.4		
V_{OPL}	Threshold Operating Voltage	L reset type Minimum supply voltage for IC operation	$R_L = 2.2k\Omega, V_{sat} \leq 0.4V$	—	0.67	0.8	V
			$R_L = 100k\Omega, V_{sat} \leq 0.4V$	—	0.55	0.7	
I_{OH}	Output Leak Current	Type B	—	—	30	nA	
		Type B, $T_a = -30 \sim +85^\circ\text{C}$	—	—	1	μA	
I_{OC}	Output Load Current	Type A $V_{CC} = 5V, V_O = 1/2V_{CC}$	-40	-25	-17	μA	
V_{OH}	Output High Voltage	Type A	$V_{CC} - 0.2$	$V_{CC} - 0.06$	—	V	

Note: Delay time can be changed by changing delay capacitor for external capacitor types.
 (Please refer to typical characteristics)

VOLTAGE DETECTING, SYSTEM RESETTING IC SERIES

TYPICAL CHARACTERISTICS

**TYPICAL CHARACTERISTICS
 THERMAL DERATING
 (MAXIMUM RATING)**

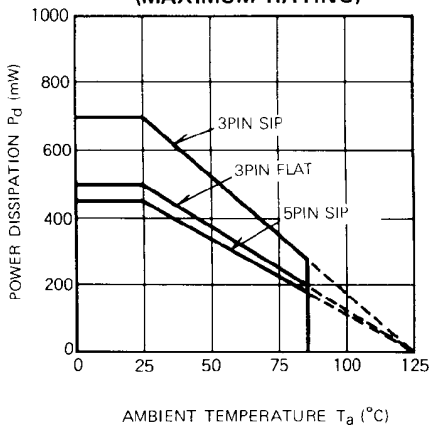

**DETECTING VOLTAGE VS.
 AMBIENT TEMPERATURE
 (Supply voltage detecting series)**

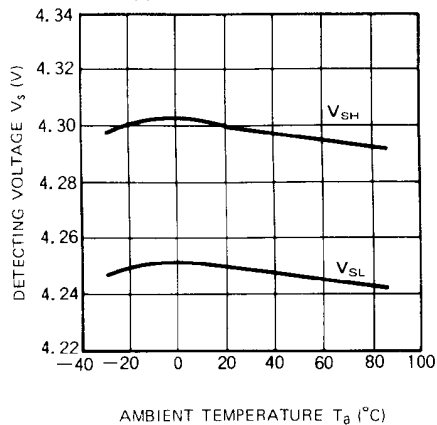

**DELAY TIME VS.
 AMBIENT TEMPERATURE
 (M5195XX, Built-in capacitor type)**

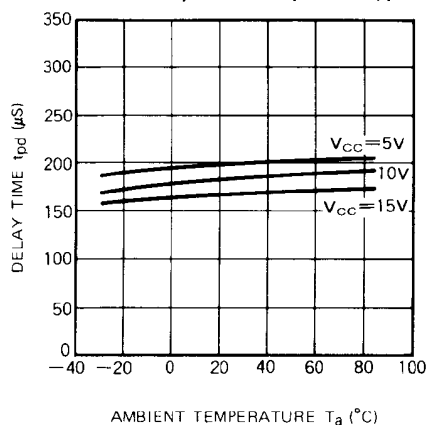

**THRESHOLD OPERATING VOLTAGE
 ([L] reset type)**

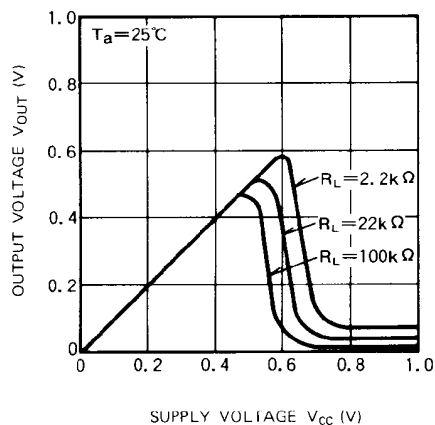

**OUTPUT SATURATION VOLTAGE VS.
 OUTPUT SINK CURRENT**

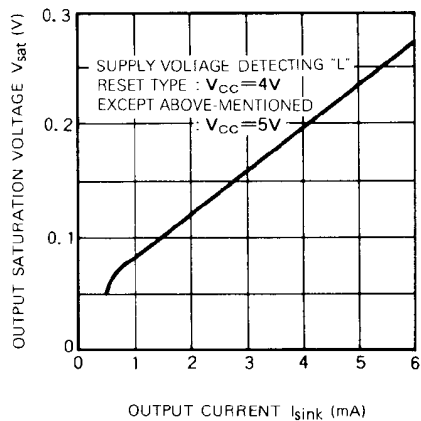

**OUTPUT LOAD CURRENT VS.
 OUTPUT VOLTAGE
 (M519XXA)**

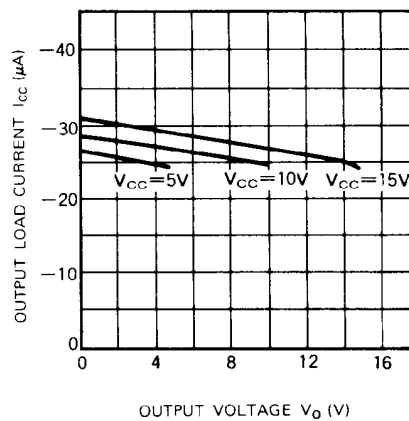

VOLTAGE DETECTING, SYSTEM RESETTING IC SERIES

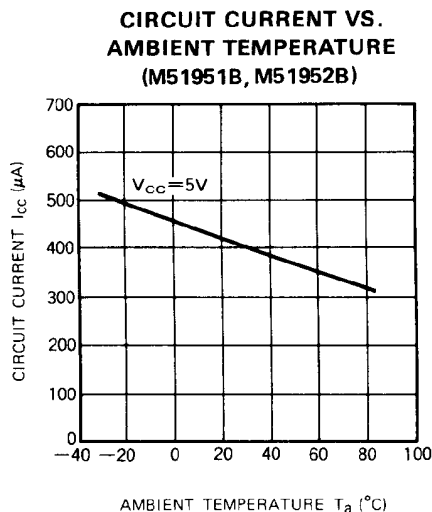

**EXAMPLE OF APPLICATION CIRCUIT
M5195XX Series Reset Circuit**

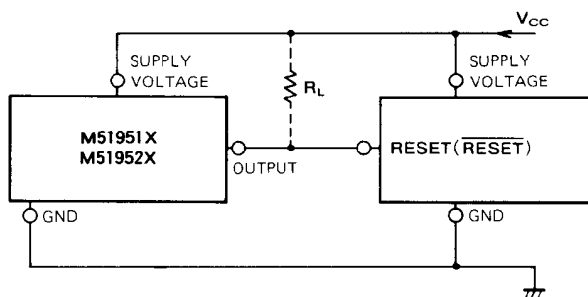

Note 1. When the detecting supply voltage is 4.25V, M51951, M51952, M51953 and M51954 are used.

When the voltage is anything except 4.25V, M51955, M51956, M51957 and M51958 are used.

Note 2. When the delay time is short, M51951, M51952, M51955 and M51956 are available. These ICs have a delay capacity and the delay time is about 200µs.

If a longer delay time is necessary, M51953, M51954, M51957 and M51958 are used.

Note 3. If M5195XX and the logic circuit have a common power supply, type A (built-in load type) can be applied whether a pull-up resistor is included in the logic circuit or not.

Note 4. The logic circuit preferably should not have a pull-down resistor, but if one is present, add load resistor R_L to overcome the pull-down resistor.

Note 5. When the reset terminal in the logic circuit is of the low reset type, M51951, M51953, M51955 and M51957 are used and when the terminal is of the high reset type, M51952, M51954, M51956 and M51958 are used.

Note 6. When a negative supply voltage is used, supply voltage side of M5195XX and the GND side are connected to negative supply voltage respectively.