

### 6 mm Square Long Travel SMD Light Touch Switches

Type: **EVQP0/EVQP1/EVQ9P**



#### ■ Features

- External dimensions : 6.0 mm×6.1 mm, Height 5.0 mm  
(Including the push plate)
- Steady and low contact resistance (100 mΩ max.)
- Excellent solderability (J-bent-type terminals)

#### ■ Recommended Applications

- Operating switches for car electronic equipment.
- Input on operating switches for telephones, electronic musical instruments, etc.

#### ■ Explanation of Part Numbers

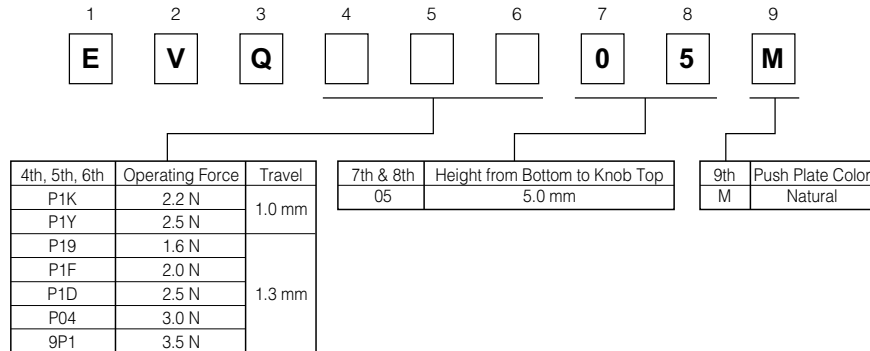

#### ■ Specifications

Type		Snap action/Push-on type SPST	
Electrical	Rating	10 μA 2 Vdc to 50 mA 12 Vdc (Resistive load)	
	Contact Resistance	100 mΩ max.	
	Insulation Resistance	100 MΩ min. (at 100 Vdc)	
	Dielectric Withstanding Voltage	250 Vac for 1 minute	
	Bouncing	10 ms max. (ON, OFF)	
Mechanical	Operating Force	1.6 N±0.5 N, 2.0 N±0.6 N 2.5 N±0.6 N 3.0 N±0.8 N 3.5 N±1.0 N	2.2 N±0.6 N 2.5 N±0.6 N
	Travel	1.3 mm±0.2 mm	1.0 mm±0.2 mm
Endurance	Operating Life	3.5 N type: 30000 cycles min. 1.6 N, 2.0 N, 2.2 N, 2.5 N, 3.0 N types: 100000 cycles min.	
Operating Temperature		-40 °C to +85 °C	
Storage Temperature		-40 °C to +85 °C (Bulk) -20 °C to +60 °C (Taping)	
Minimum Quantity/Packing Unit		2000 pcs. Embossed Taping (Reel Pack)	
Quantity/Carton		10000 pcs.	

Design and specifications are each subject to change without notice. Ask factory for the current technical specifications before purchase and/or use.  
Should a safety concern arise regarding this product, please be sure to contact us immediately.

00 Sep. 2010

■ Dimensions in mm (not to scale)

EVQP0

EVQP1

EVQ9P

(Embossed Taping)

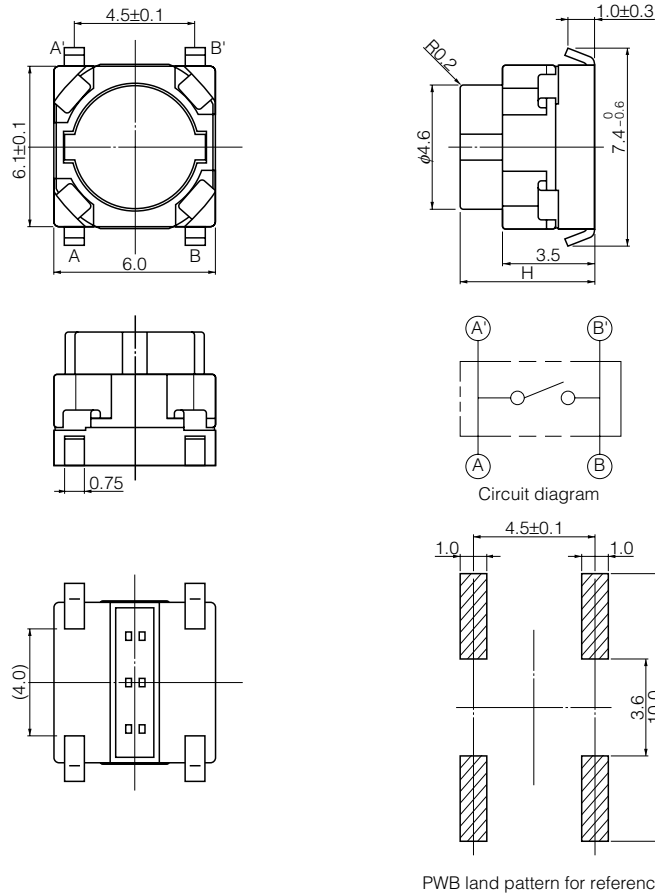

Part Numbers	Operating Force	Travel	H=Height	Push Plate Color	Operating Life
EVQP1K05M	2.2 N	1.0 mm	5.0 mm	Natural	100000 cycles
EVQP1Y05M	2.5 N	1.0 mm	5.0 mm	Natural	100000 cycles
EVQP1905M	1.6 N	1.3 mm	5.0 mm	Natural	100000 cycles
EVQP1F05M	2.0 N	1.3 mm	5.0 mm	Natural	100000 cycles
EVQP1D05M	2.5 N	1.3 mm	5.0 mm	Natural	100000 cycles
EVQP0405M	3.0 N	1.3 mm	5.0 mm	Natural	100000 cycles
EVQ9P105M	3.5 N	1.3 mm	5.0 mm	Natural	30000 cycles

Design and specifications are each subject to change without notice. Ask factory for the current technical specifications before purchase and/or use. Should a safety concern arise regarding this product, please be sure to contact us immediately.

00 Sep. 2010

### Recommended Reflow Soldering Conditions

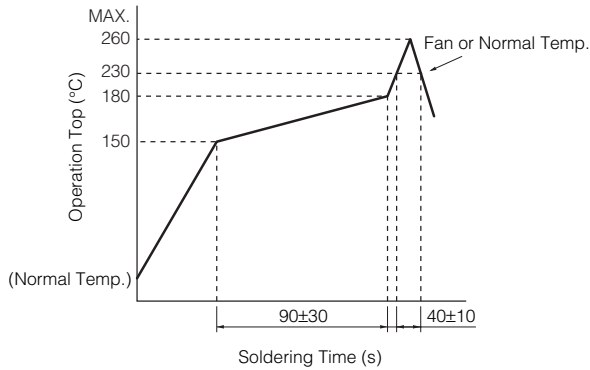

### Embossed Carrier Taping

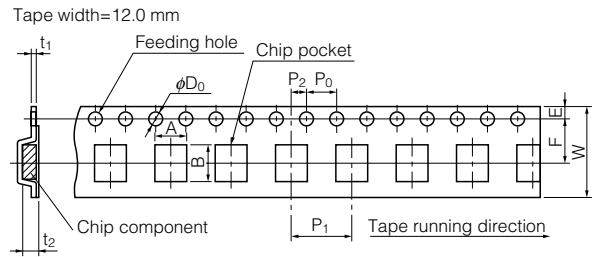

Unit: mm

Part No.	Height	A	B	W	F	E	P <sub>1</sub>	P <sub>2</sub>	P <sub>0</sub>	D <sub>0</sub> Dia.	t <sub>1</sub>	t <sub>2</sub>
EVQP1 EVQ9P	5.0	6.4±0.2	7.9±0.2	12.0±0.3	5.5±0.1	1.75±0.10	8.0±0.1	2.0±0.1	4.0±0.1	1.5 <sup>+0.1</sup> <sub>-0</sub>	0.4±0.1	5.25±0.20

### Standard Reel Dimensions in mm (not to scale)

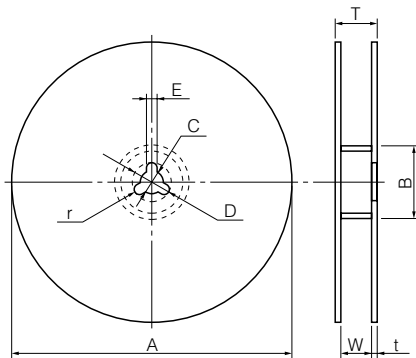

Item	A	B	C	D	E
Rate (mm)	φ370.0±2.0	φ50.0 min.	φ13.0±0.5	φ21.0±1.0	2.0±0.5
Item	W	T	t	r	
Rate (mm)	14.0±1.5	—	1.0 to 3.0	1.0±0.5	