

Pyroelectric Infrared Sensors/Fresnel Lens

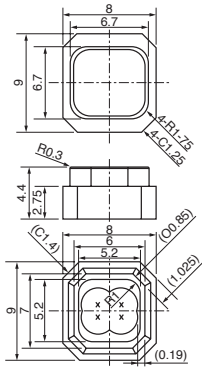

IML-0642



- 1) Insert a sensor into Fresnel lens like each tab is overlapped. (In case there are two tabs on Fresnel lens, the field of view is determined by your choice (TabA or B on Fresnel lens). Please see following page(s) for more details to see which characteristic of field of view is preferable for your application.)
- 2) Push the sensor into Fresnel lens until the top face of sensor reaches to the stopper inside Fresnel lens.
- 3) Please prepare a housing yourself that is put onto Fresnel lens as shown in FigureA. The hatching area shown in Figure A, must be obscured by the housing in order to prevent mis-detection. Unless otherwise unexpected infrared ray comes though the hatching area.

(in mm)
General tolerance : ±0.2

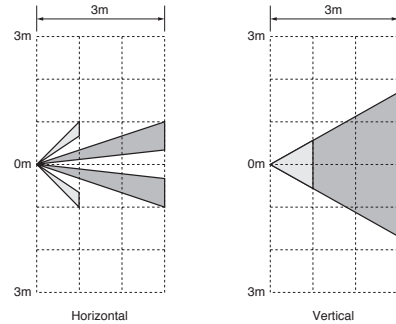

IML-0658

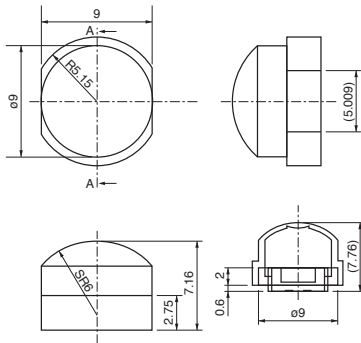

- 1) Insert a sensor into Fresnel lens like each tab is overlapped. (In case there are two tabs on Fresnel lens, the field of view is determined by your choice (TabA or B on Fresnel lens). Please see following page(s) for more details to see which characteristic of field of view is preferable for your application.)
- 2) Push the sensor into Fresnel lens until the top face of sensor reaches to the stopper inside Fresnel lens.
- 3) Please prepare a housing yourself that is put onto Fresnel lens as shown in FigureA. The hatching area shown in Figure A, must be obscured by the housing in order to prevent mis-detection. Unless otherwise unexpected infrared ray comes though the hatching area.

(in mm)
General tolerance : ±0.2

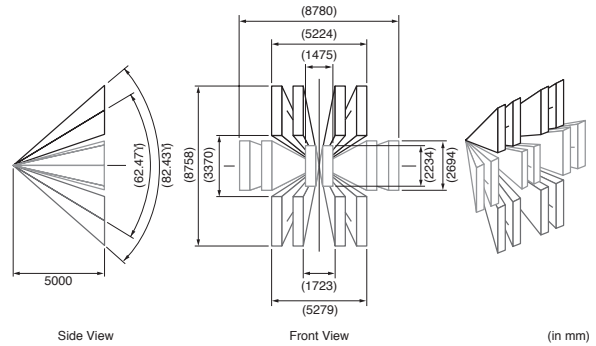

IML-0669

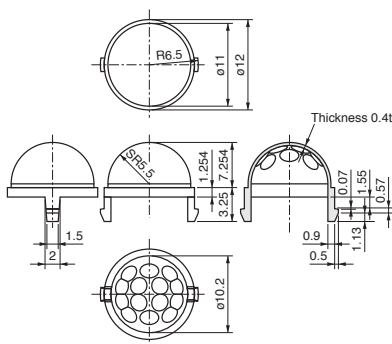

- 1) Insert a sensor into Fresnel lens like each tab is overlapped. (In case there are two tabs on Fresnel lens, the field of view is determined by your choice (TabA or B on Fresnel lens). Please see following page(s) for more details to see which characteristic of field of view is preferable for your application.)
- 2) Push the sensor into Fresnel lens until the top face of sensor reaches to the stopper inside Fresnel lens.
- 3) Please prepare a housing yourself that is put onto Fresnel lens as shown in FigureA. The hatching area shown in Figure A, must be obscured by the housing in order to prevent mis-detection. Unless otherwise unexpected infrared ray comes though the hatching area.

(in mm)
General tolerance : ±0.2

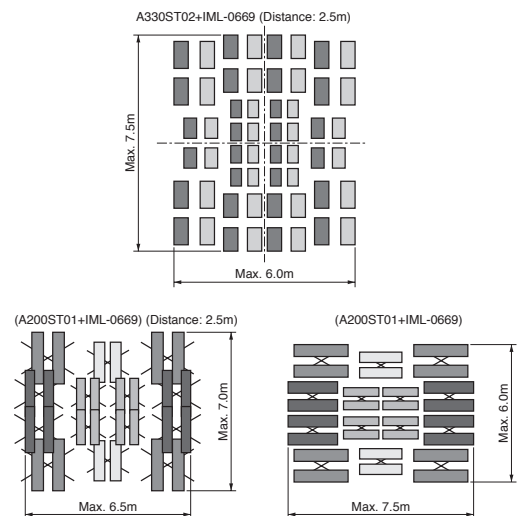

Fresnel lens are available upon request.