

10/100 BASE PULSE TRANSFORMER FOR PCMCIA

462 Boston St - Topsfield, MA 01983 - Phone: 978-887-8050 - Fax: 978-887-5434

- Design FOR 10/100 MB/s TX & ATM 155 MB/s APPLICATION
- Meets ANSI X3.236-1995 TP-PMD,100BASE-TX,ATM 155Bps UNI,AND IEEE 802.3u AND 802.3i specifications.
- Very low profile PCMCIA/PC CARD, SMD package.
- Storage temperature range: -40°C to +125°C.



Electrical Specifications @ 25°C Operating Temperature range: 0°C to +70°C

HI-POT : 1500Vrms.

Primary OCL inductance : 350 uH Min @ 100KHz/0.1Vrms,8.0mA/DC

Part Number	Turn ratio (±5%)		L.L (uH Max)	CW/W (pF Max)	Insertion loss (dB Max)			Return loss (dB Min)			Cross talk (dB Min)			Differential to Common Mode Rejection (dB Min)			
	RX	TX			0.3-100 MHz	100-125 MHz	30 MHz	60 MHz	80 MHz	30 MHz	60 MHz	100 MHz	30 MHz	50 MHz	100 MHz	150 MHz	
14ST0001P	1CT:1CT	1.14CT:1CT	-	-	-1.0	-	-16	-12	-10	-40	-35	-35	-	-	-	-	
14ST0002P	1CT:1CT	1.25CT:1CT	-	-	-1.3	-	-16	-12	-10	-40	-35	-35	-	-	-	-	
14ST8515*	1CT:1CT	1CT:1CT	0.5	28	-1.3	-	-16	-12	-10	-40	-38	-	-	-	-		
14ST9012P	1CT:1CT	1CT:1CT	0.35	28	-1.3	-	-18	-13	-11	-40	-40	-35	-40	-35	-30	-20	
14ST9013P	1CT:1CT	1CT:1CT	-	-	-1.1	-	-16	-12	-11	-40	-38	-42/-40	-40/-35	-30	-20		
14ST9014P	1CT:1CT	1CT:1CT	-	-	-1.3	-	-16	-12	-10	-35	-38	-42/-40	-40/-35	-30	-20		

Mechanicals

14ST8515

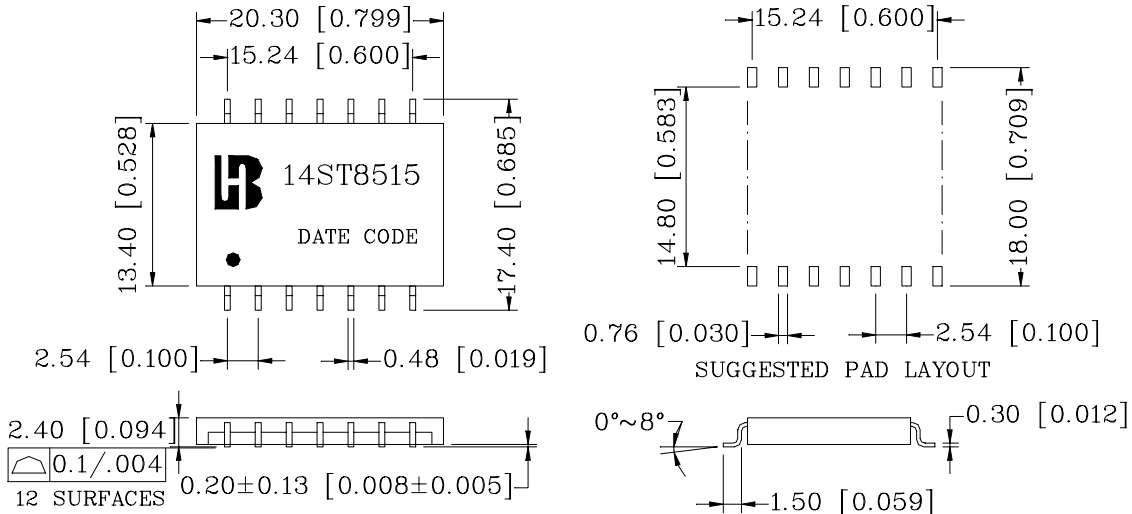

Bothhand USA. e-mail: sales@bothhandusa.com <http://www.bothhand.com>

462 Boston St - Topsfield, MA 01983 - Phone: 978-887-8050 - Fax: 978-887-5434

10/100 BASE PULSE TRANSFORMER FOR PCMCIA



462 Boston St - Topsfield, MA 01983 - Phone: 978-887-8050 - Fax: 978-887-5434

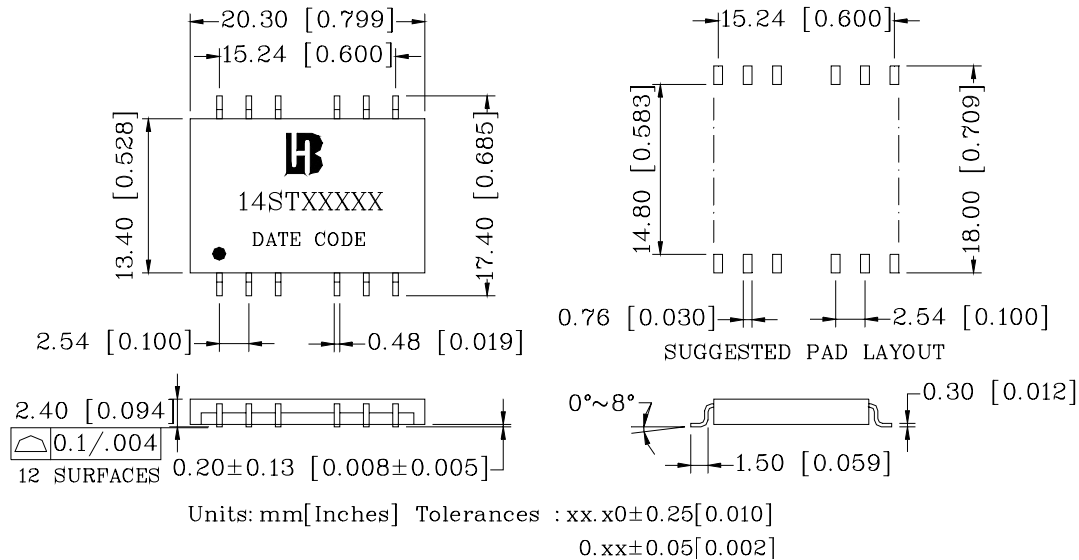

Schematics

14T0001P

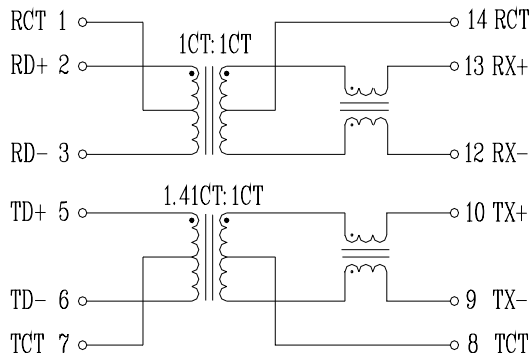

14ST0002P

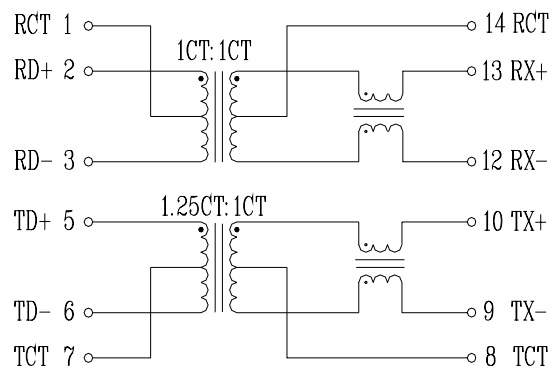

14ST8515

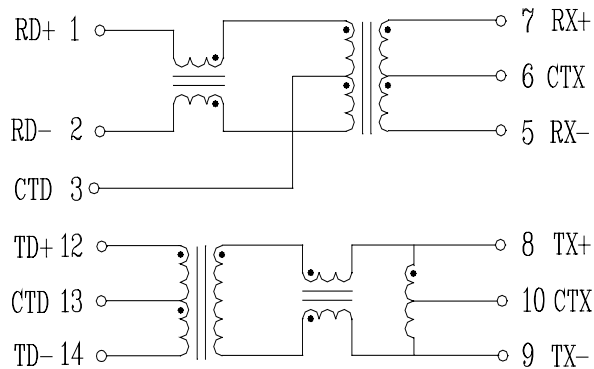

14ST9012P

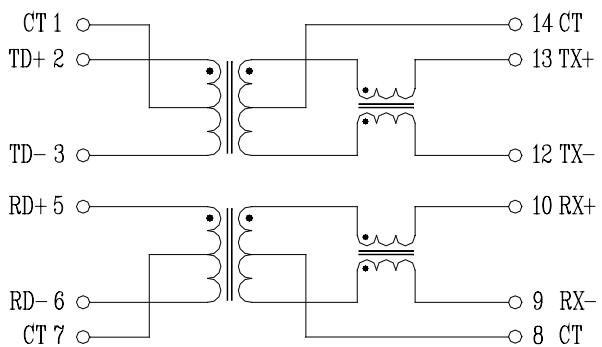

Bothhand USA. e-mail: sales@bothhandusa.com <http://www.bothhand.com>

462 Boston St - Topsfield, MA 01983 - Phone: 978-887-8050 - Fax: 978-887-5434

10/100 BASE PULSE TRANSFORMER FOR PCMCIA

462 Boston St - Topsfield, MA 01983 - Phone: 978-887-8050 - Fax: 978-887-5434

