

CIRCUIT SIZE	DIM. A	DIM. B	DIM. C	DIM. D
20	13.90	9.00	12.58	12.40
	.547	.354	.495	.488
30	18.90	14.00	17.58	17.40
	.744	.551	.692	.685
40	23.90	19.00	22.58	22.40
	.941	.748	.889	.882
50	28.90	24.00	27.58	27.40
	1.138	.945	1.086	1.079
60	33.90	29.00	32.58	32.40
	1.335	1.142	1.283	1.276
64	35.90	31.00	34.58	34.40
	1.413	1.220	1.361	1.354
70	38.90	34.00	37.58	37.40
	1.531	1.339	1.480	1.472
80	43.90	39.00	42.58	42.40
	1.728	1.535	1.676	1.669
84	45.90	41.00	44.58	44.40
	1.807	1.614	1.755	1.748
90	48.90	44.00	47.58	47.40
	1.925	1.732	1.873	1.866
100	53.90	49.00	52.58	52.40
	2.122	1.929	2.070	2.063
110	58.90	54.00	57.58	57.40
	2.319	2.126	2.267	2.260
120	63.90	59.00	62.58	62.40
	2.516	2.323	2.464	2.457

NOTES:

- HOUSING MATERIAL: LIQUID CRYSTAL POLYMER (LCP) GLASS FILLED; UL RATING: 94V-0; COLOR: WHITE OR BLACK
- TERMINAL MATERIAL: PHOSPHOR BRONZE; 0.205/.0080 THICK
- VACUUM CAP MATERIAL: STAINLESS STEEL; 0.255/.0100 THICK
- PLATING FINISHES: SEE SHEET 2
- PRODUCT SPECIFICATION: PS-71436-999
- PACKAGING SPECIFICATIONS: REFER TO CHART ON SHEET 2.
- MATES WITH: 71439 SERIES. SEE SHEET 2 FOR MATING VIEW AND STACK HEIGHT.
- PEGS ARE OPTIONAL. REFER TO CHART ON SHEET 2.
- VACUUM PICK & PLACE CAP IS OPTIONAL. REFER TO CHART ON SHEET 2.
- THIS PART CONFORMS TO EIA STANDARD 700 AAAB FOR 1.0mm TWO-PART CONNECTORS FOR USE WITH PARALLEL PRINTED BOARDS.
- COPLANARITY OF SMT TAILS: 0.10/.004 MAX.
- 64-CIRCUIT PLUG ASSEMBLY WITH PEGS AND VACUUM CAP SHOWN FOR ILLUSTRATION PURPOSES ONLY.
- DIMENSIONS ARE IN mm/IN. INCH DIMENSIONS SHOWN FOR REFERENCE ONLY.
- ASSEMBLY TO HAVE DATE CODE: XX XX WEEK YEAR

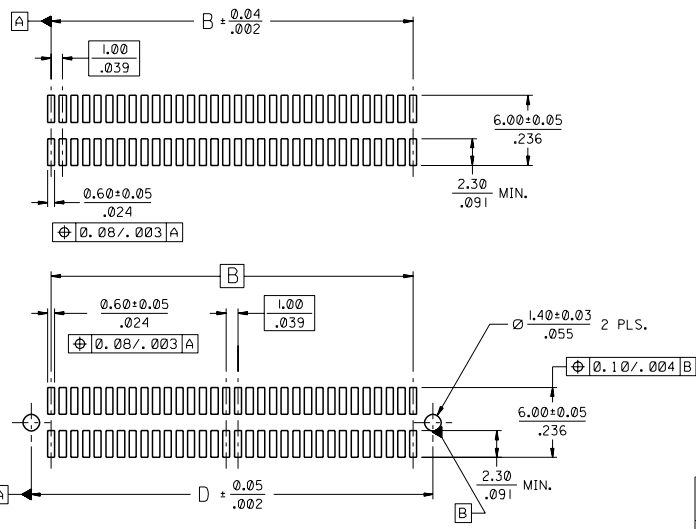

RECOMMENDED PCB LAYOUT (WITH AND WITHOUT PEGS)

RECOMMENDED PCB THICKNESS: 1.00±0.10/.039±.004 MIN.

CHG TO BLACK CAP ON 71436-2964 ECN UDT#1999-0018 MORGAN 98/01/09 ADD 2964 PER ECN U81534 MCFARLA 98-1-23		UNLESS OTHERWISE SPECIFIED TOLERANCES ANGULAR 1/2° INCH METRIC 2 PLACE ± .005 --- 3 PLACE ± .011 ± 0.13 1 PLACE --- ± 0.25 DRAFT WHERE APPLICABLE MUST REMAIN WITHIN DIMENSIONS	TITLE SALES ASSY, 1.0mm BOARD-TO-BOARD PLUG CONNECTOR, 4.30/.169 STACK HEIGHT MOLEX INCORPORATED SHEET NO. 2 OF 2 DATE 03/23/95 U.S.A.
REVISIONS LTR. REVISIONS LTR. REVISIONS LTR. REVISIONS LTR.		REEDED BY REEDED BY APP'D BY BIXLER SCALE 4 : 1	FILE NAME 5743621.DWG THIS DRAWING CONTAINS INFORMATION THAT IS PROPRIETARY TO MOLEX INC. AND SHOULD NOT BE USED WITHOUT WRITTEN PERMISSION.

13 12 11 10 9 8 7 6 71436 4 3 2 1

WHITE (NATURAL) MATERIAL

CIRCUIT SIZE	PLUG ASSEMBLY ITEM NUMBER	PEGS	CONTACT PLATING (SEE PLATING NOTES)	PICK & PLACE CAP	PACKAGING SPEC. NUMBER	PACKAGING TYPE
64	71436-2164	YES	574	NO	PK-70873-0607	TUBE
64	71436-2364	YES	574	YES	PK-70873-0607	TUBE
64	71436-2464	YES	574	YES	PK-70873-0634	TAPE & REEL
64	71436-2564	NO	574	NO	PK-70873-0606	TUBE
64	71436-2764	NO	574	YES	PK-70873-0606	TUBE
64	71436-2864	NO	574	YES	PK-70873-0634	TAPE & REEL
64	71436-2264	NO	649	YES	PK-70873-0634	TAPE & REEL

PLATING NOTES:

574: SELECTIVE GOLD (Au) IN THE CONTACT AREA; THICKNESS = 0.76 MICROMETERS (30 MICROINCHES) MINIMUM; SELECTIVE TIN-LEAD (Sn-Pb) ALLOY IN THE PC TAIL AREA; THICKNESS = 1.88 MICROMETERS (75 MICROINCHES) MINIMUM; NICKEL UNDERPLATE OVERALL.

649: SELECTIVE GOLD (Au) IN THE CONTACT AREA; THICKNESS = 1.27 MICROMETERS (50 MICROINCHES) MINIMUM; SELECTIVE TIN-LEAD (Sn-Pb) ALLOY IN THE PC TAIL AREA; THICKNESS = 1.88 MICROMETERS (75 MICROINCHES) MINIMUM; NICKEL UNDERPLATE OVERALL.

BLACK MATERIAL WITH PICK & PLACE CAP

CIRCUIT SIZE	PLUG ASSEMBLY ITEM NUMBER	PEGS	CONTACT PLATING (SEE NOTES PAGE 2)	PICK & PLACE CAP	PACKAGING SPEC. NUMBER	PACKAGING TYPE
64	71436-2964	NO	574	YES	PK-70873-0634	TAPE & REEL

RECOMMENDED PLUG/RECEPTACLE COMBINATION FOR MATED STACK HEIGHT PER EIA STANDARD 700 AAAB

MATED STACK HEIGHT	RECEPTACLE HEIGHT	RECEPTACLE SERIES NO.	PLUG HEIGHT	PLUG SERIES NO.
10.00/.394	5.30/.209	71439-0***	4.30/.169	71436-2***
12.00/.472	7.30/.287	71439-1***	4.30/.169	71436-2***
13.00/.512	8.30/.327	71439-2***	4.30/.169	71436-2***
15.00/.591	10.30/.406	71439-3***	4.30/.169	71436-2***

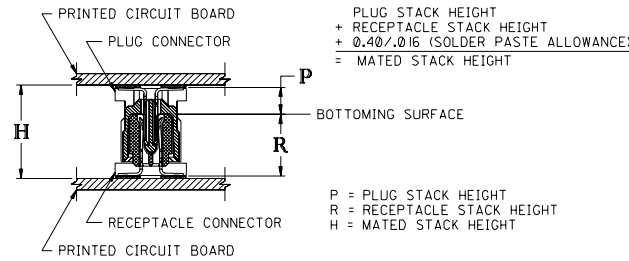

MM
INCH

G SEE SHEET I		UNLESS OTHERWISE SPECIFIED TOLERANCES ANGULAR 1/2°		REVISE ONLY ON CAD SYSTEM	
F SEE SHEET I	E SEE SHEET I	INCH METRIC		TITLE SALES ASSY, 1.0mm BOARD-TO-BOARD PLUG CONNECTOR, 4.30/.169 STACK HEIGHT	
D SEE SHEET I	C SEE SHEET I	3 PLACE ± .005	---	PART NO. MOLEX INCORPORATED SHEET NO. DATE	
B SEE SHEET I	A SEE SHEET I	2 PLACE ± .01	+0.13	68532 U.S.A. 2 03/23/95	
H SEE SHEET I	A SEE SHEET I	1 PLACE ---	+0.25	DRAWING NO. SDA-71436-2***	
LTR. REVISIONS	LTR. REVISIONS	DRAFT WHERE APPLICABLE MUST REMAIN WITHIN DIMENSIONS		FILE NAME: ST143622.DWG	
		APPROVED BY: BIXLER	SCALE: NONE	THIS DRAWING CONTAINS INFORMATION THAT IS PROPRIETARY TO MOLEX INC. AND SHOULD NOT BE USED WITHOUT WRITTEN PERMISSION. CPP C	

13 12 11 10 9 8 7 6 5 4 3 2 1