

REVISIONS		
SYM	DESCRIPTION	REVISED BY DATE APPR

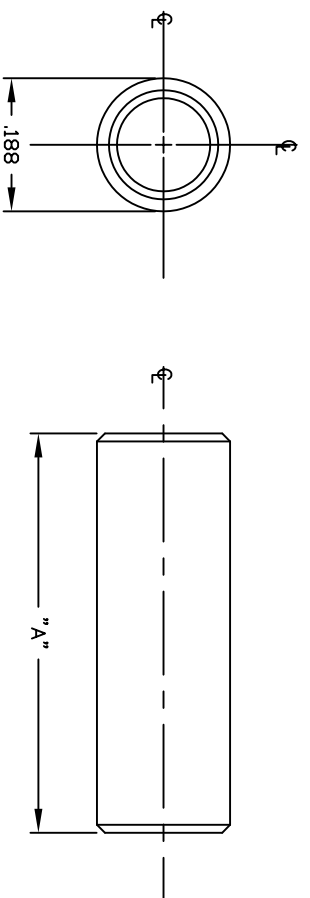
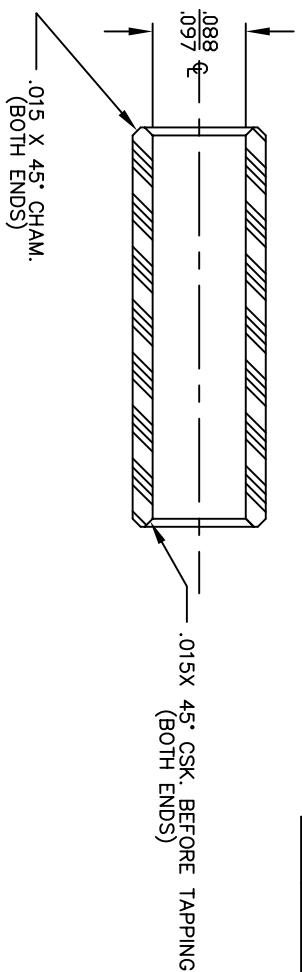

PART NO.	DIM "A"
9000	.125
9001	.187
9002	.250
9003	.312
9004	.375
9005	.437
9006	.500
9007	.562
9008	.625
9009	.687
9010	.750
9011	.812
9012	.875
9013	.937
9014	1.000

MATERIAL 360 BRASS		FINISH NICKEL	
DIMENSIONAL TOLERANCES UNLESS OTHERWISE SPECIFIED		TITLE	
XX	XXX	XXXX	BRASS ROUND 3/16"
---	---	---	SPACERS
---	---	---	#2 CLEARANCE
FRACTIONS	ANGLES	SCALE	
---	---	NONE	
HEAT TREAT	---	---	
PLOT SCALE	1=1		
DRAWN: T. LORD	DATE 02/10/03	SIZE	DRAWING NUMBER
CHECKED: T. LORD	DATE 02/10/03	B	SD: SMP-00413
APPROVED: T. LORD	DATE 02/10/03	A	ISSUE

**ABBATRON**  
Electronic Connectors and Hardware  
632 Arch Street, Meadville, Pa. 16335