

RECOMMENDED CABLE (FFC)

n : NO. OF CONTACTS

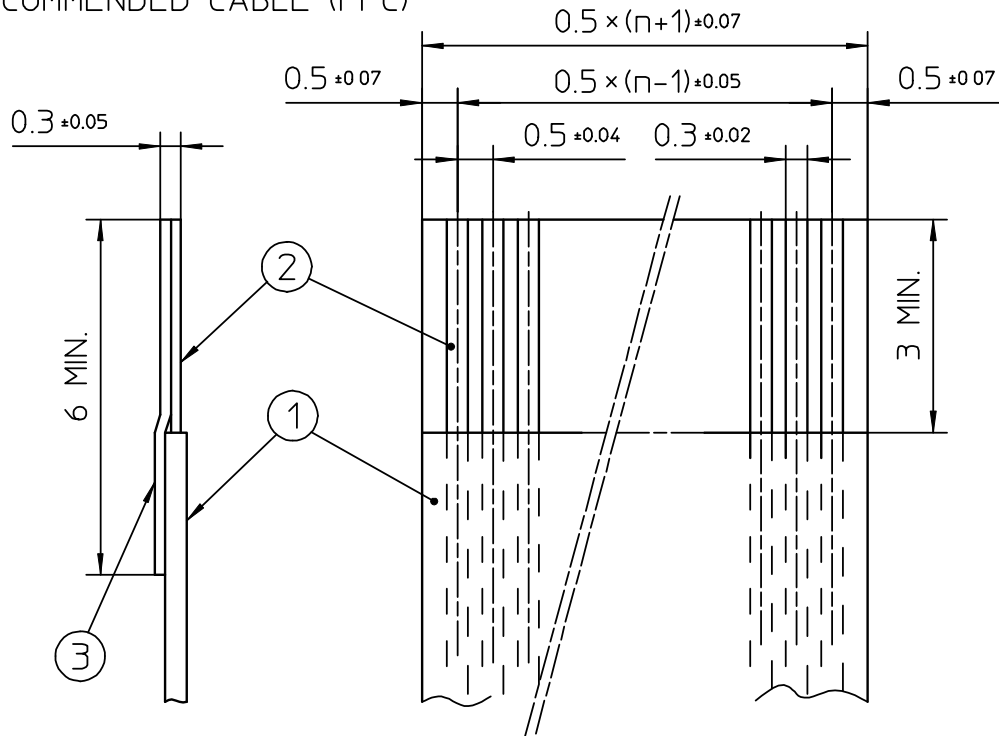

KIND OF FFC (NOTE3)	DIMENSIONAL TOLERANCE			
	a	b	c	d
1	±0.07	±0.04	±0.05	±0.02
2	±0.1	±0.03	±0.03	±0.025

PT. NO.	PARTS NAME	MATERIAL	NOTE
1	INSULATOR	FLAME RESISTING POLYESTER OR EQUAL	_____
2	CONDUCTOR	COPPER FOIL:THICKNESS 35 OR 50 μm	PLATING : TIN OR SOLDER 1 μm MIN.
3	SUPPORTING TAPE	FLAME RESISTING POLYESTER OR EQUAL	_____

NOTES

1. NO BURR AT EACH PORTION.
2. NO PEELING IN COMMON USE.
3. EITHER KIND1 OR KIND2 OF FFC CAN ACCEPT DIMENSIONAL TOLERANCE a,b,c AND d.

				SCALE	×	RECOMMENDED CABLE	
				DIM. IN	mm	CAT NO.	
				DESIGNED		SFV__R-1/2ST__	
				DRAWN		DRAWING NO	REV
				CHECKED		JSA 92457	
				APPROVED		 DF-136 REV.B	
REV.	DATE	DESCRIPTION	DWN.	APPD.	DATE		

RECOMMENDED CABLE (FPC)

n · NO. OF CONTACTS

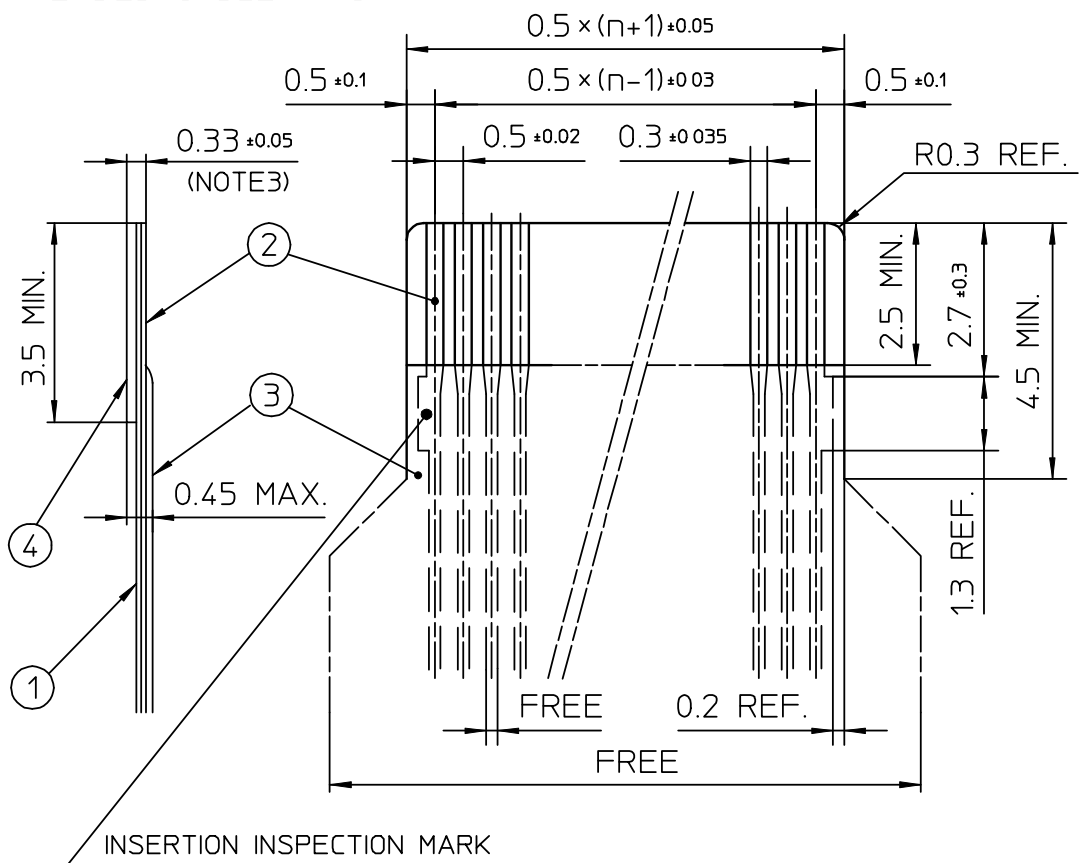

PT. NO.	PARTS NAME	MATERIAL	THICKNESS(μm)
1	BASE FILM	POLYIMIDE OR POLYESTER OR EQUAL	25
2	CONDUCTOR	COPPER FOIL(PLATING : SOLDER 1μm MIN.)	35
3	OVERLAY	POLYIMIDE OR POLYESTER OR EQUAL	—
4	SUPPORTING TAPE	POLYESTER OR POLYIMIDE OR EQUAL	188

NOTES

1. NO BURR AT EACH PORTION
2. NO PEELING IN COMMON USE.
3. TOTAL THICKNESS LIMIT OF EACH MATERIAL (INCLUDING ADHESIVE AGENT) IS SPECIFIED.

				SCALE	×	RECOMMENDED CABLE	
				DIM. IN	mm	CAT NO.	
				DESIGNED		SFV__R-1/2ST__	
				DRAWN		DRAWING NO	REV
				CHECKED		JSA 92456	
				APPROVED		 DF-136 REV.B	
REV.	DATE	DESCRIPTION	DWN. APPD.	DATE			

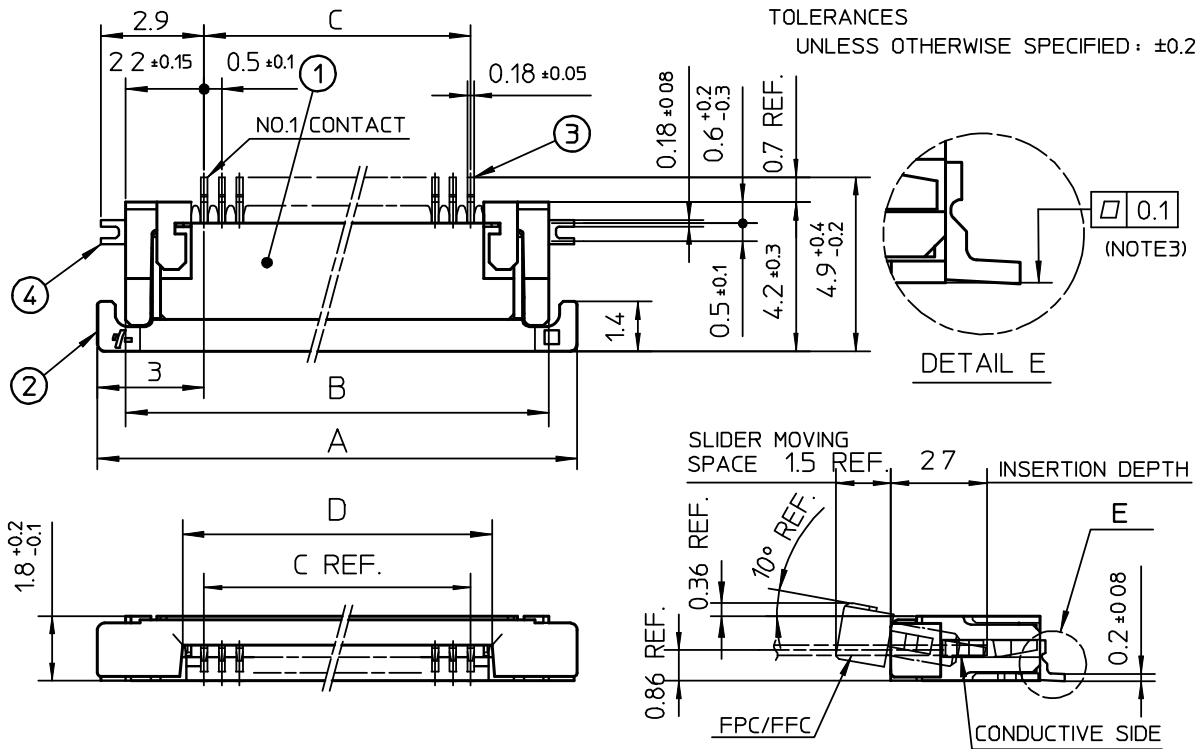

PT. NO	PARTS NAME	MATERIAL	Q'TY	NOTE
1	HOUSING	POLYAMIDE RESIN GLASS REINFORCED (UL94V-0)	1	COLOR : BLACK
2	SLIDER	PPS RESIN GLASS REINFORCED (UL94V-0)	1	COLOR : BROWN
3	CONTACT	PHOSPHOR BRONZE	n	PLATING : TIN ALLOY
4	MOUNTING PLATE		2	

RECOMMENDED PC BOARD LAYOUT
(COMPONENT SIDE)

PATTERN FOR MOUNTING PLATE FIXING

n : NO. OF CONTACTS

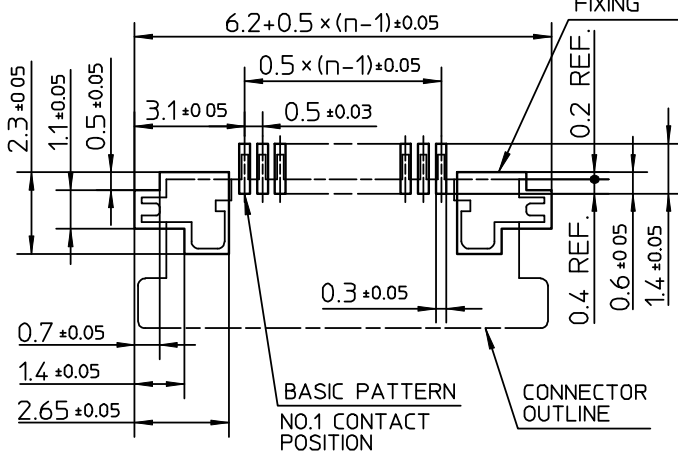

NOTES

1. THIS PRODUCT IS THE CONNECTOR USED FOR FPC/FFC AND COPEs WITH AUTOMATIC MOUNTING (SMT).
2. THIS PRODUCT IS LOWER CONTACT TYPE CONNECTOR
3. FLATNESS OF CONTACT TERMINAL AND MOUNTING PLATE MUST BE WITHIN TOLERANCE IN E PORTION DETAILED DRAWING.

				SCALE	∞	CONNECTOR USED FOR FPC/FFC WITH 0.5 MM CONTACT SPACING	
				DIM. IN	mm	CAT NO.	
				DESIGNED		SFV__R-1ST__	
				DRAWN		DRAWING NO	REV
				CHECKED		JSA 92451	
				APPROVED			
REV.	DATE	DESCRIPTION	DWN.	APPD.	DATE		

CAT. NO. & DIMENSIONS

NO OF CONTACTS (n)	CAT. NO.	DIMENSIONS (NOTE2)			
		A ± 02	B ± 02	C ± 01	D ± 01
4	SFV4R-1/2ST__	75	5.9	1.5	2.7
5	SFV5R-1/2ST__	80	6.4	2.0	3.2
6	SFV6R-1/2ST__	85	6.9	2.5	3.7
7	SFV7R-1/2ST__	90	7.4	3.0	4.2
8	SFV8R-1/2ST__	95	7.9	3.5	4.7
9	SFV9R-1/2ST__	100	8.4	4.0	5.2
10	SFV10R-1/2ST__	105	8.9	4.5	5.7
11	SFV11R-1/2ST__	110	9.4	5.0	6.2
12	SFV12R-1/2ST__	115	9.9	5.5	6.7
13	SFV13R-1/2ST__	120	10.4	6.0	7.2
14	SFV14R-1/2ST__	125	10.9	6.5	7.7
15	SFV15R-1/2ST__	130	11.4	7.0	8.2
16	SFV16R-1/2ST__	135	11.9	7.5	8.7
17	SFV17R-1/2ST__	140	12.4	8.0	9.2
18	SFV18R-1/2ST__	145	12.9	8.5	9.7
19	SFV19R-1/2ST__	150	13.4	9.0	10.2
20	SFV20R-1/2ST__	155	13.9	9.5	10.7
21	SFV21R-1/2ST__	160	14.4	10.0	11.2
22	SFV22R-1/2ST__	165	14.9	10.5	11.7
23	SFV23R-1/2ST__	170	15.4	11.0	12.2
24	SFV24R-1/2ST__	175	15.9	11.5	12.7
25	SFV25R-1/2ST__	180	16.4	12.0	13.2
26	SFV26R-1/2ST__	185	16.9	12.5	13.7
27	SFV27R-1/2ST__	190	17.4	13.0	14.2
28	SFV28R-1/2ST__	195	17.9	13.5	14.7
29	SFV29R-1/2ST__	200	18.4	14.0	15.2
30	SFV30R-1/2ST__	205	18.9	14.5	15.7
31	SFV31R-1/2ST__	210	19.4	15.0	16.2
32	SFV32R-1/2ST__	215	19.9	15.5	16.7
33	SFV33R-1/2ST__	220	20.4	16.0	17.2
34	SFV34R-1/2ST__	225	20.9	16.5	17.7
35	SFV35R-1/2ST__	230	21.4	17.0	18.2

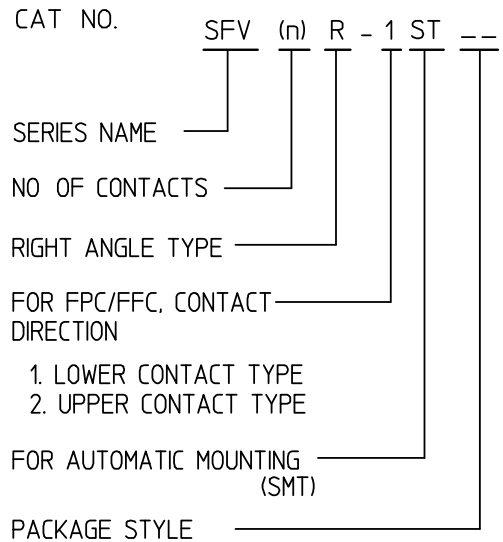

NOTES

1. THIS PRODUCT IS THE CONNECTOR USED FOR FPC/FFC AND COPEs WITH AUTOMATIC MOUNTING (SMT).
2. SEE PART DRAWINGS FOR DIMENSIONS A~D.

					SCALE	∞	CAT NO. TABLE FOR 0.5 mm CONTACT SPACING CONNECTOR	
					DIM. IN	mm	CAT NO.	
					DESIGNED		SFV__R-1/2ST__	
					DRAWN		DRAWING NO	REV
					CHECKED		JSA 92450	
					APPROVED		 DF-136 REV.B	
REV.	DATE	DESCRIPTION	DWN.	APPD.	DATE			

CAT. NO. & DIMENSIONS

NO. OF CONTACTS (n)	CAT. NO.	DIMENSIONS (NOTE3)		
		F ± 5	G ± 0.3	H ± 0.1
4	SFV4R-1/2STE1	20.4	16	—
5	SFV5R-1/2STE1	20.4	16	—
6	SFV6R-1/2STE1	20.4	16	—
7	SFV7R-1/2STE1	28.4	24	—
8	SFV8R-1/2STE1	28.4	24	—
9	SFV9R-1/2STE1	28.4	24	—
10	SFV10R-1/2STE1	28.4	24	—
11	SFV11R-1/2STE1	28.4	24	—
12	SFV12R-1/2STE1	28.4	24	—
13	SFV13R-1/2STE1	28.4	24	—
14	SFV14R-1/2STE1	28.4	24	—
15	SFV15R-1/2STE1	28.4	24	—
16	SFV16R-1/2STE1	28.4	24	—
17	SFV17R-1/2STE1	28.4	24	—
18	SFV18R-1/2STE1	28.4	24	—
19	SFV19R-1/2STE1	28.4	24	—
20	SFV20R-1/2STE1	28.4	24	—
21	SFV21R-1/2STE1	28.4	24	—
22	SFV22R-1/2STE1	28.4	24	—
23	SFV23R-1/2STE1	36.4	32	28.4
24	SFV24R-1/2STE1	36.4	32	28.4
25	SFV25R-1/2STE1	36.4	32	28.4
26	SFV26R-1/2STE1	36.4	32	28.4
27	SFV27R-1/2STE1	36.4	32	28.4
28	SFV28R-1/2STE1	36.4	32	28.4
29	SFV29R-1/2STE1	36.4	32	28.4
30	SFV30R-1/2STE1	36.4	32	28.4
31	SFV31R-1/2STE1	48.4	44	40.4
32	SFV32R-1/2STE1	48.4	44	40.4
33	SFV33R-1/2STE1	48.4	44	40.4
34	SFV34R-1/2STE1	48.4	44	40.4
35	SFV35R-1/2STE1	48.4	44	40.4

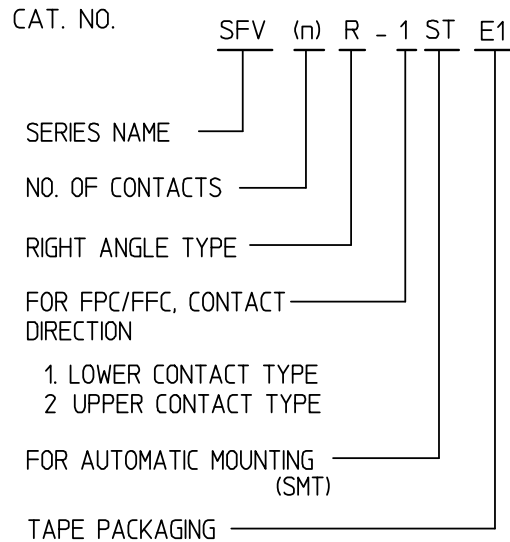

NOTES

1. THIS PRODUCT IS THE CONNECTOR USED FOR FPC/FFC AND COPEs WITH AUTOMATIC MOUNTING (SMT).
2. THIS CATALOG NO. INDICATES PLASTIC TAPE PACKAGED CONNECTOR.
3. SEE PART DRAWINGS FOR DIMENSIONS F~H.

					SCALE	∞	CAT NO TABLE FOR PLASTIC TAPE PACKAGED 0.5 mm CONTACT SPACING CONNECTOR	
					DIM. IN	mm	CAT NO.	
					DESIGNED		SFV__R-1/2STE1	
					DRAWN		DRAWING NO	REV
					CHECKED		JSA 92453	
					APPROVED		 DF-136 REV.B	
REV.	DATE	DESCRIPTION	DWN.	APPD.	DATE			

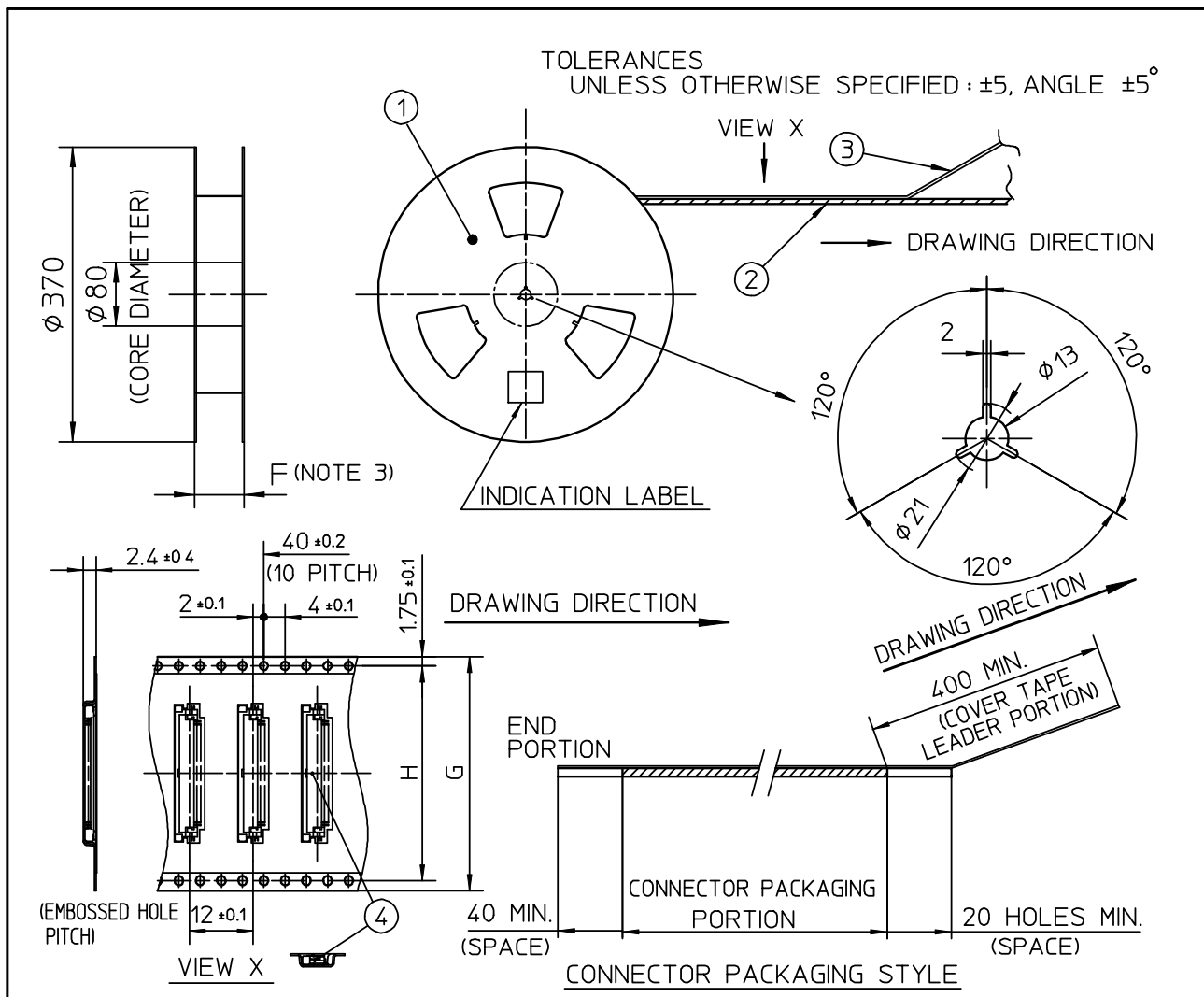

PT. NO.	PARTS NAME	CAT. NO.	MATERIAL	Q'TY	NOTE
1	REEL	_____	CARDBOARD	1	COLOR : WHITE
2	PLASTIC (EMBOSS) TAPE	_____	A-PET	—	COLOR : TRANSPARENCY
3	COVER	_____	POLYESTER	—	COLOR : TRANSPARENCY
4	CONNECTOR	SFV__R-1ST__	SEE ATTACHED DWG.	3000	LOWER CONTACT TYPE

NOTES

1. THIS IS PLASTIC TAPE PACKAGED CONNECTOR USED FOR FPC/FFC AND COPES WITH AUTOMATIC MOUNTING (SMT).
2. SEE JIS C 0806 (PACKING OF ELECTRONIC COMPONENTS ON CONTINUOUS TAPES (SURFACE MOUNTING DEVICES)) FOR SHAPE AND DIMENSIONS OF PLASTIC (EMBOSS) TAPE AND REEL.
3. F DIMENSION IS PORTION OF THE CORE.

				SCALE	∞	PLASTIC TAPE PACKAGED 0.5 mm CONTACT SPACING CONNECTOR	
				DIM. IN	mm	CAT NO.	
				DESIGNED		SFV__R-1STE1	
				DRAWN		DRAWING NO	REV
				CHECKED		JSA 92454	
				APPROVED		DF-136 REV.B	
REV.	DATE	DESCRIPTION	DWN. APPD.	DATE			

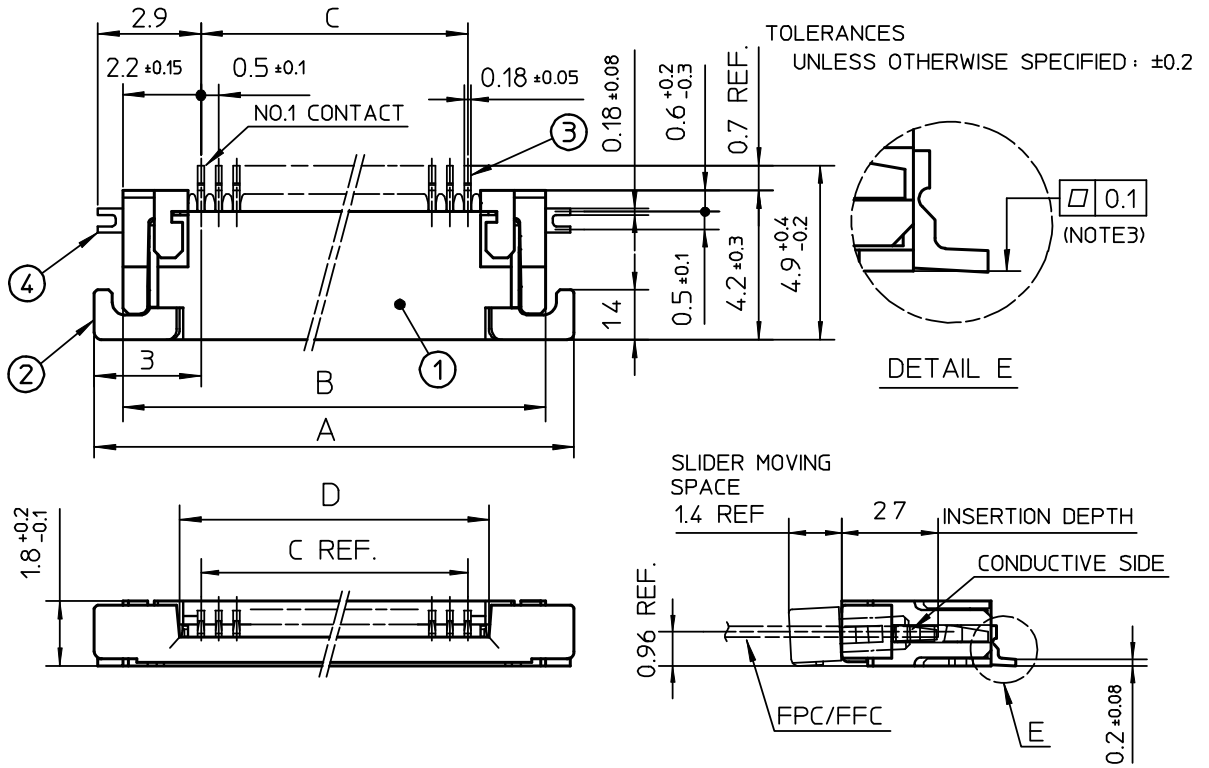

PT. NO.	PARTS NAME	MATERIAL	Q'TY	NOTE
1	HOUSING	POLYAMIDE RESIN GLASS REINFORCED (UL94V-0)	1	COLOR :BLACK
2	SLIDER	PPS RESIN GLASS REINFORCED (UL94V-0)	1	COLOR :BROWN
3	CONTACT	PHOSPHOR BRONZE	n	PLATING :TIN ALLOY
4	MOUNTING PLATE		2	

RECOMMENDED PC BOARD LAYOUT
(COMPONENT SIDE)

PATTERN FOR MOUNTING PLATE
FIXING

n : NO. OF CONTACTS

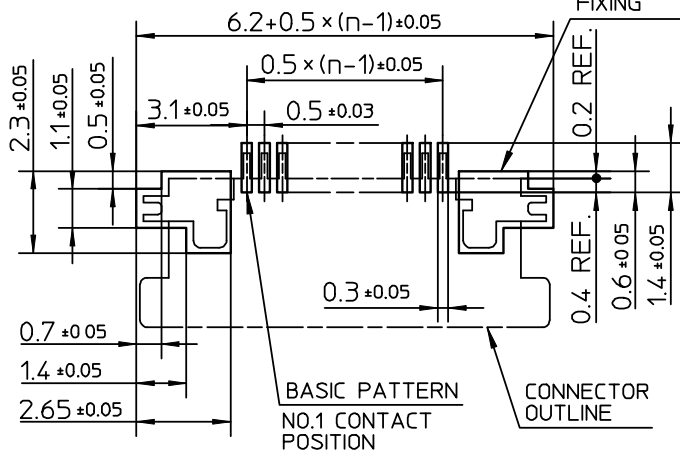

NOTES

1. THIS PRODUCT IS THE CONNECTOR USED FOR FPC/FFC AND COPES WITH AUTOMATIC MOUNTING (SMT).
2. THIS PRODUCT IS UPPER CONTACT TYPE CONNECTOR
3. FLATNESS OF CONTACT TERMINAL AND MOUNTING PLATE MUST BE WITHIN TOLERANCE IN E PORTION DETAILED DRAWING.

				SCALE	∞	CONNECTOR USED FOR FPC/FFC WITH 0.5 MM CONTACT SPACING	
				DIM. IN	mm	CAT NO.	
				DESIGNED		SFV__R-2ST__	
				DRAWN		DRAWING NO	REV
				CHECKED		JSA 92452	
				APPROVED			
REV.	DATE	DESCRIPTION	DWN.	APPD.	DATE		

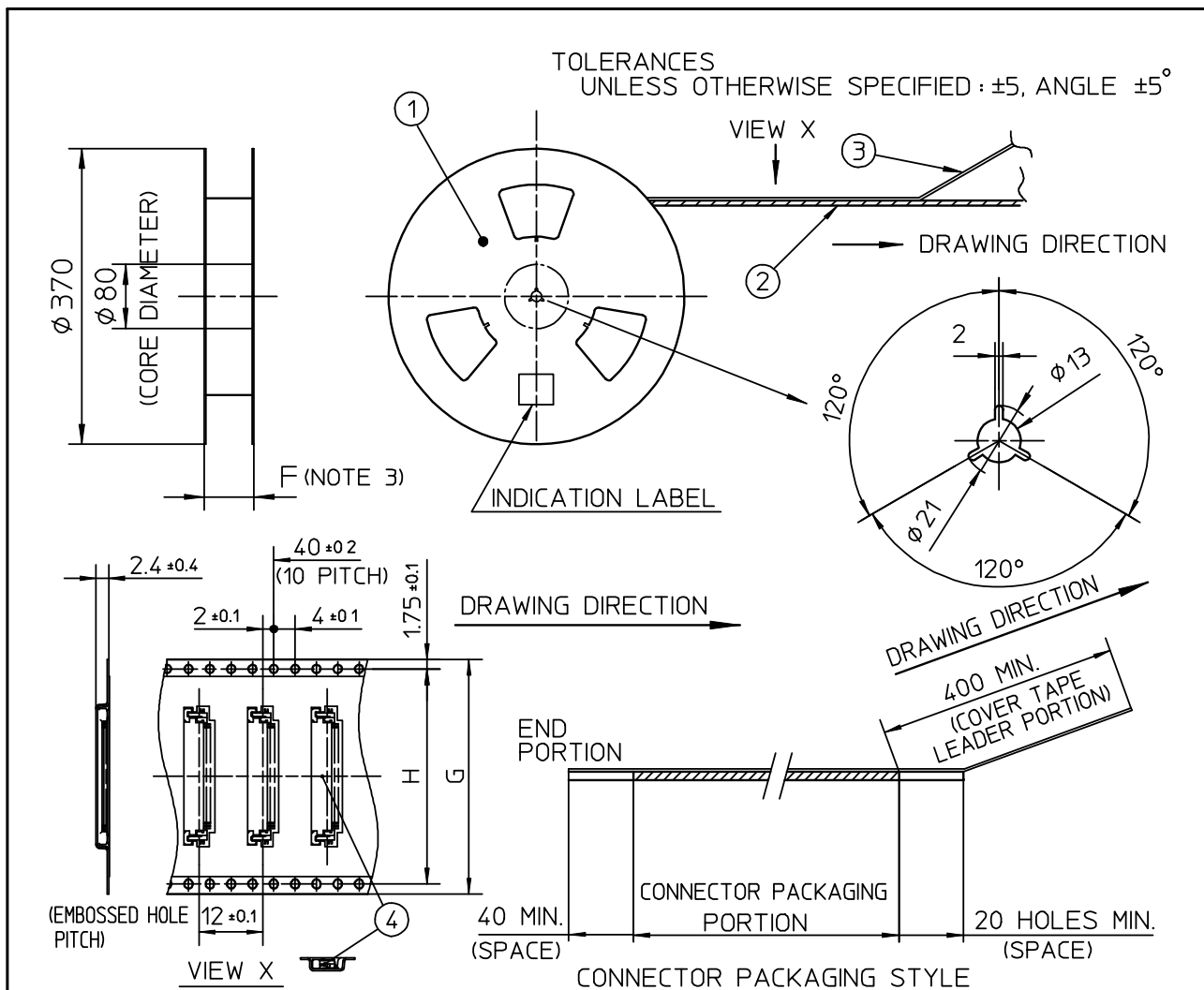

PT. NO	PARTS NAME	CAT. NO.	MATERIAL	Q'TY	NOTE
1	REEL	_____	CARDBOARD	1	COLOR : WHITE
2	PLASTIC (EMBOSS) TAPE	_____	A-PET	—	COLOR : TRANSPARENCY
3	COVER	_____	POLYESTER	—	COLOR : TRANSPARENCY
4	CONNECTOR	SFV__R-2ST__	SEE ATTACHED DWG.	3000	UPPER CONTACT TYPE

NOTES

- THIS IS PLASTIC TAPE PACKAGED CONNECTOR USED FOR FPC/FFC AND COPES WITH AUTOMATIC MOUNTING (SMT).
- SEE JIS C 0806 (PACKING OF ELECTRONIC COMPONENTS ON CONTINUOUS TAPES (SURFACE MOUNTING DEVICES)) FOR SHAPE AND DIMENSIONS OF PLASTIC (EMBOSS) TAPE AND REEL
- F DIMENSION IS PORTION OF THE CORE.

				SCALE	\times	PLASTIC TAPE PACKAGED 0.5 mm CONTACT SPACING CONNECTOR	
				DIM. IN	mm	CAT NO.	
				DESIGNED		SFV__R-2STE1	
				DRAWN		DRAWING NO	REV
				CHECKED		JSA 92455	
				APPROVED		 DF-136 REV.B	
REV.	DATE	DESCRIPTION	DWN.	APPD.	DATE		

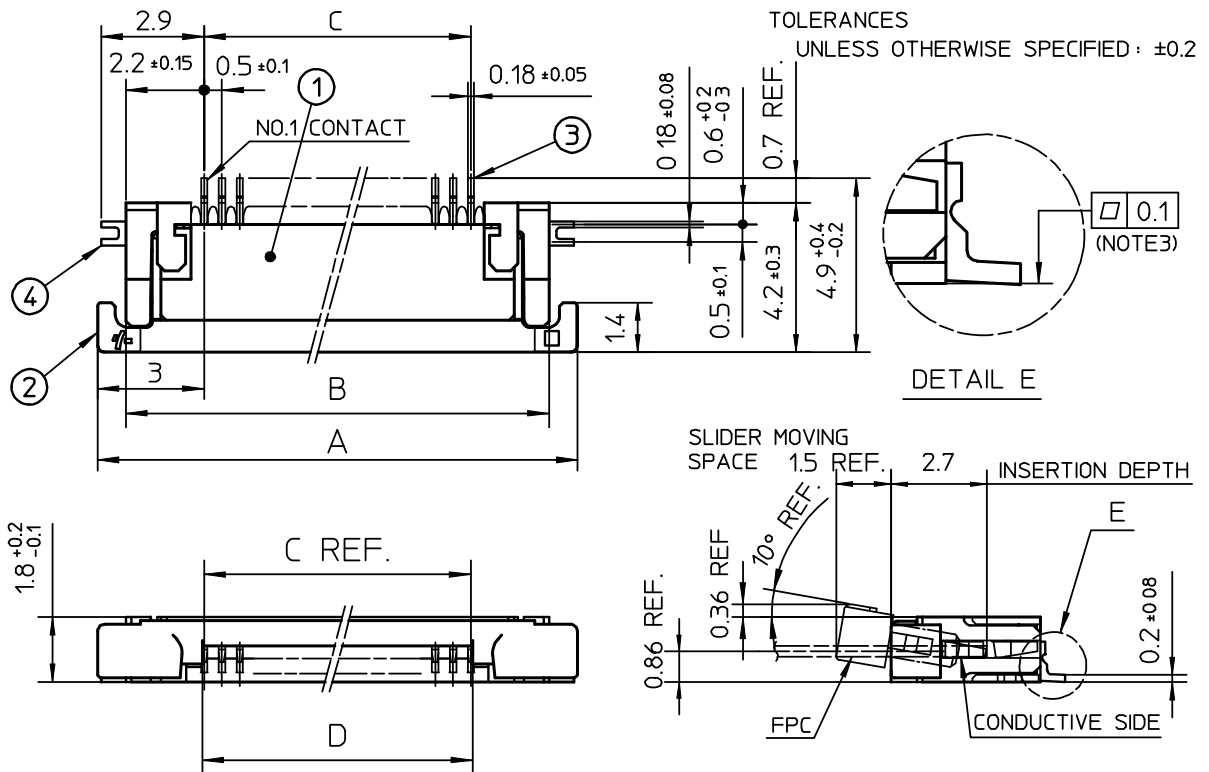

TOLERANCES
UNLESS OTHERWISE SPECIFIED: ±0.2

PT. NO.	PARTS NAME	MATERIAL	Q'TY	NOTE
1	HOUSING	POLYAMIDE RESIN GLASS REINFORCED (UL94V-0)	1	COLOR:BLACK
2	SLIDER	PPS RESIN GLASS REINFORCED (UL94V-0)	1	COLOR:BLACK
3	CONTACT	PHOSPHOR BRONZE	n	PLATING:TIN ALLOY
4	MOUNTING PLATE		2	

n: NO. OF CONTACTS

RECOMMENDED PC BOARD LAYOUT
(COMPONENT SIDE)

PATTERN FOR
MOUNTING PLATE
FIXING

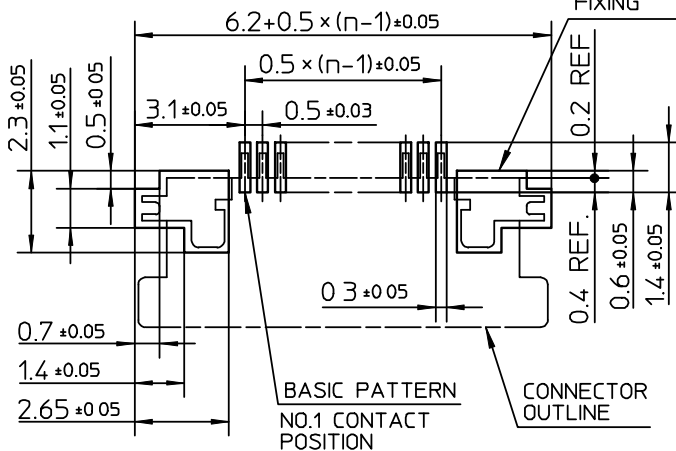

NOTES

1. THIS PRODUCT IS THE CONNECTOR USED FOR FPC AND COPES WITH AUTOMATIC MOUNTING (SMT).
2. THIS PRODUCT IS LOWER CONTACT TYPE CONNECTOR WITH CABLE LOCK MECHANISM.
3. FLATNESS OF CONTACT TERMINAL AND MOUNTING PLATE MUST BE WITHIN TOLERANCE IN E PORTION DETAILED DRAWING.

				SCALE	∞	CONNECTOR USED FOR FPC WITH 0.5 MM CONTACT SPACING	
				DIM. IN	mm	CAT NO.	
				DESIGNED		SFV__R-3ST__	
				DRAWN		DRAWING NO	REV
				CHECKED		JSA 92601	
				APPROVED			
REV.	DATE	DESCRIPTION	DWN.	APPD.	DATE		

CAT. NO. & DIMENSIONS

NO OF CONTACTS (n)	CAT NO	DIMENSIONS (NOTE2)			
		A ± 0.2	B ± 0.2	C ± 0.1	D ± 0.1
4	SFV 4R-3/4ST__	7.5	5.9	1.5	1.6
5	SFV 5R-3/4ST__	8.0	6.4	2.0	2.1
6	SFV 6R-3/4ST__	8.5	6.9	2.5	2.6
7	SFV 7R-3/4ST__	9.0	7.4	3.0	3.1
8	SFV 8R-3/4ST__	9.5	7.9	3.5	3.6
9	SFV 9R-3/4ST__	10.0	8.4	4.0	4.1
10	SFV10R-3/4ST__	10.5	8.9	4.5	4.6
11	SFV11R-3/4ST__	11.0	9.4	5.0	5.1
12	SFV12R-3/4ST__	11.5	9.9	5.5	5.6
13	SFV13R-3/4ST__	12.0	10.4	6.0	6.1
14	SFV14R-3/4ST__	12.5	10.9	6.5	6.6
15	SFV15R-3/4ST__	13.0	11.4	7.0	7.1
16	SFV16R-3/4ST__	13.5	11.9	7.5	7.6
17	SFV17R-3/4ST__	14.0	12.4	8.0	8.1
18	SFV18R-3/4ST__	14.5	12.9	8.5	8.6
19	SFV19R-3/4ST__	15.0	13.4	9.0	9.1
20	SFV20R-3/4ST__	15.5	13.9	9.5	9.6
21	SFV21R-3/4ST__	16.0	14.4	10.0	10.1
22	SFV22R-3/4ST__	16.5	14.9	10.5	10.6
23	SFV23R-3/4ST__	17.0	15.4	11.0	11.1
24	SFV24R-3/4ST__	17.5	15.9	11.5	11.6
25	SFV25R-3/4ST__	18.0	16.4	12.0	12.1
26	SFV26R-3/4ST__	18.5	16.9	12.5	12.6
27	SFV27R-3/4ST__	19.0	17.4	13.0	13.1
28	SFV28R-3/4ST__	19.5	17.9	13.5	13.6
29	SFV29R-3/4ST__	20.0	18.4	14.0	14.1
30	SFV30R-3/4ST__	20.5	18.9	14.5	14.6
31	SFV31R-3/4ST__	21.0	19.4	15.0	15.1
32	SFV32R-3/4ST__	21.5	19.9	15.5	15.6
33	SFV33R-3/4ST__	22.0	20.4	16.0	16.1
34	SFV34R-3/4ST__	22.5	20.9	16.5	16.6
35	SFV35R-3/4ST__	23.0	21.4	17.0	17.1

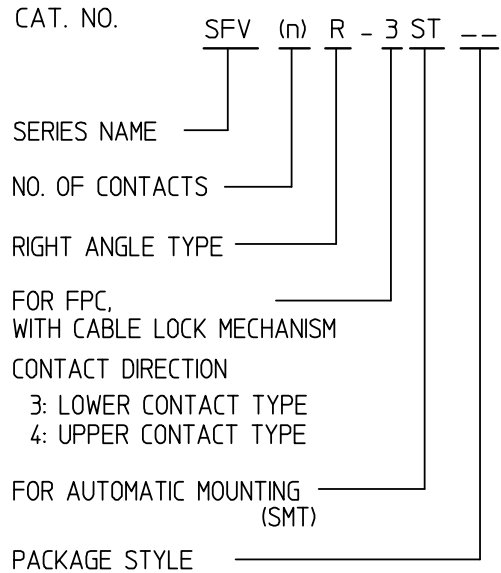

NOTES

1. THIS PRODUCT IS THE CONNECTOR USED FOR FPC AND COPES WITH AUTOMATIC MOUNTING (SMT).
2. SEE PART DRAWINGS FOR DIMENSIONS A~D.
3. THIS PRODUCT IS THE CONNECTOR WITH CABLE LOCK MECHANISM.

				SCALE	∞	CAT. NO. TABLE FOR 0.5 mm CONTACT SPACING CONNECTOR	
				DIM. IN	mm	CAT NO.	
				DESIGNED		SFV__R-3/4ST__	
				DRAWN		DRAWING NO	REV
				CHECKED		JSA 92600	
				APPROVED		 DF-136 REV.B	
REV.	DATE	DESCRIPTION	DWN.	APPD.	DATE		

CAT. NO. & DIMENSIONS

NO. OF CONTACTS (n)	CAT. NO.	DIMENSIONS (NOTE3)		
		F ± 5	G ± 0.3	H ± 0.1
4	SFV 4R-3/4STE1	20.4	16	—
5	SFV 5R-3/4STE1	20.4	16	—
6	SFV 6R-3/4STE1	20.4	16	—
7	SFV 7R-3/4STE1	28.4	24	—
8	SFV 8R-3/4STE1	28.4	24	—
9	SFV 9R-3/4STE1	28.4	24	—
10	SFV10R-3/4STE1	28.4	24	—
11	SFV11R-3/4STE1	28.4	24	—
12	SFV12R-3/4STE1	28.4	24	—
13	SFV13R-3/4STE1	28.4	24	—
14	SFV14R-3/4STE1	28.4	24	—
15	SFV15R-3/4STE1	28.4	24	—
16	SFV16R-3/4STE1	28.4	24	—
17	SFV17R-3/4STE1	28.4	24	—
18	SFV18R-3/4STE1	28.4	24	—
19	SFV19R-3/4STE1	28.4	24	—
20	SFV20R-3/4STE1	28.4	24	—
21	SFV21R-3/4STE1	28.4	24	—
22	SFV22R-3/4STE1	28.4	24	—
23	SFV23R-3/4STE1	36.4	32	28.4
24	SFV24R-3/4STE1	36.4	32	28.4
25	SFV25R-3/4STE1	36.4	32	28.4
26	SFV26R-3/4STE1	36.4	32	28.4
27	SFV27R-3/4STE1	36.4	32	28.4
28	SFV28R-3/4STE1	36.4	32	28.4
29	SFV29R-3/4STE1	36.4	32	28.4
30	SFV30R-3/4STE1	36.4	32	28.4
31	SFV31R-3/4STE1	48.4	44	40.4
32	SFV32R-3/4STE1	48.4	44	40.4
33	SFV33R-3/4STE1	48.4	44	40.4
34	SFV34R-3/4STE1	48.4	44	40.4
35	SFV35R-3/4STE1	48.4	44	40.4

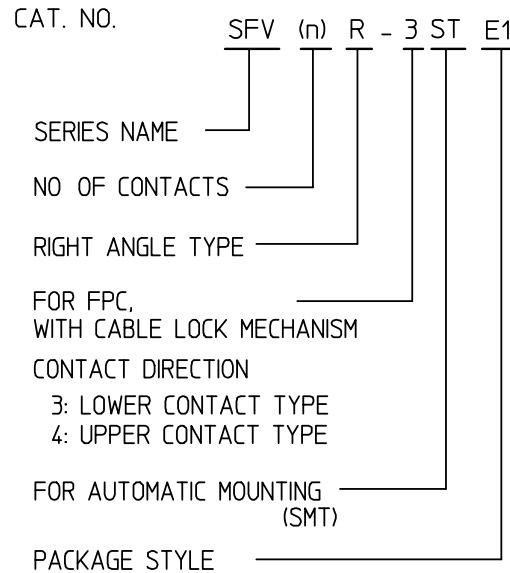

NOTES

1. THIS PRODUCT IS THE CONNECTOR USED FOR FPC AND COPES WITH AUTOMATIC MOUNTING (SMT).
2. THIS CATALOG NO. INDICATES PLASTIC TAPE PACKAGED
3. SEE PART DRAWINGS FOR DIMENSIONS F-H.
4. THIS PRODUCT IS THE CONNECTOR WITH CABLE LOCK MECHANISM.

					SCALE	∞	CAT. NO. TABLE FOR PLASTIC TAPE PACKAGED 0.5 mm CONTACT SPACING CONNECTOR	
					DIM. IN	mm	CAT NO.	
					DESIGNED		SFV__R-3/4STE1	
					DRAWN		DRAWING NO	REV
					CHECKED		JSA 92603	
					APPROVED		 DF-136 REV.B	
REV.	DATE	DESCRIPTION	DWN.	APPD.	DATE			

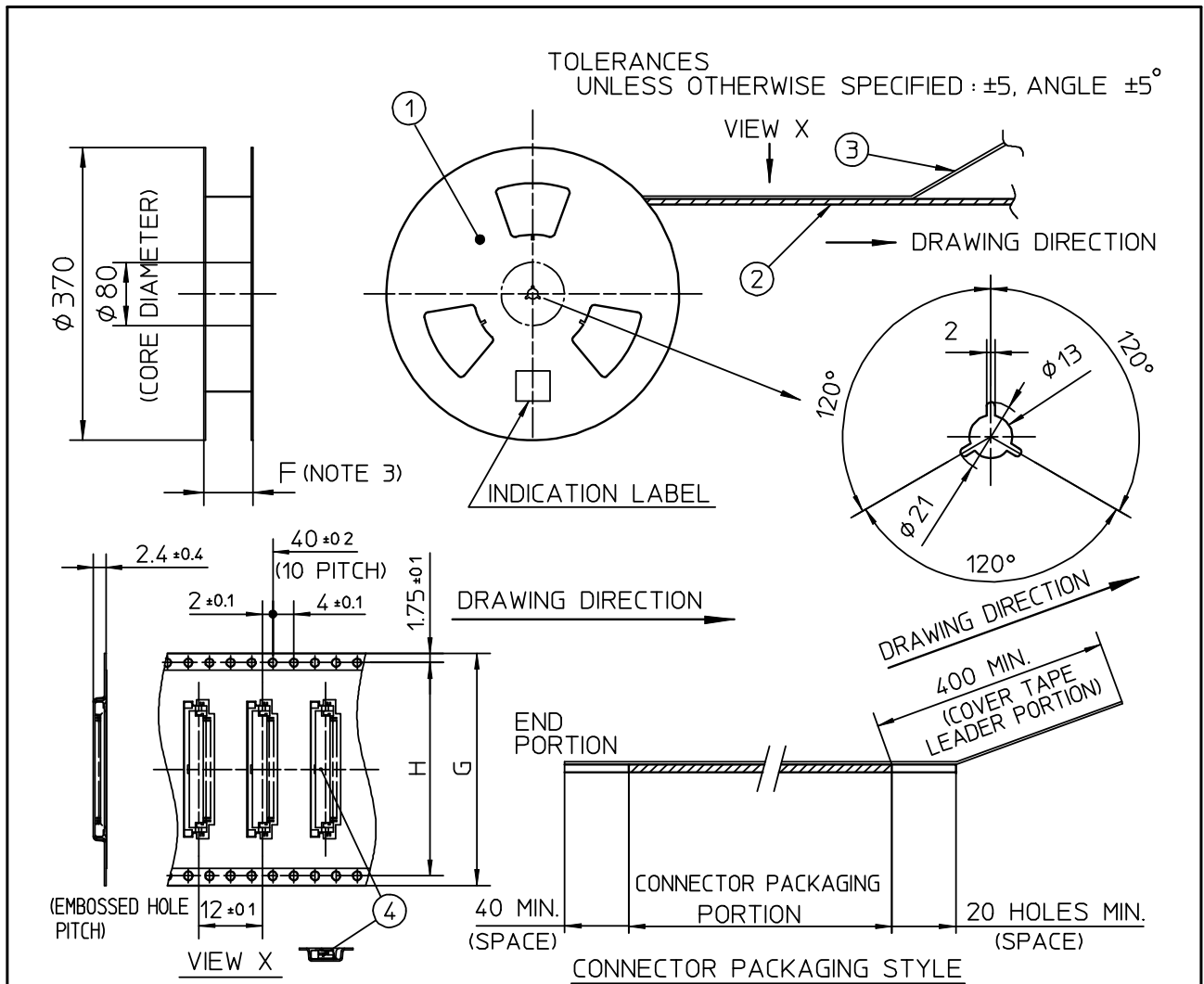

PT. NO.	PARTS NAME	CAT. NO	MATERIAL	Q'TY	NOTE
1	REEL	—	CARDBOARD	1	COLOR : WHITE
2	PLASTIC (EMBOSS) TAPE	—	A-PET	—	COLOR : TRANSPARENCY
3	COVER	—	POLYESTER	—	COLOR : TRANSPARENCY
4	CONNECTOR	SFV__R-3ST__	SEE ATTACHED DWG.	3000	LOWER CONTACT TYPE WITH CABLE LOCK MECHANISM

NOTES

- THIS IS PLASTIC TAPE PACKAGED CONNECTOR USED FOR FPC AND COPES WITH AUTOMATIC MOUNTING (SMT).
- SEE JIS C 0806 (PACKING OF ELECTRONIC COMPONENTS ON CONTINUOUS TAPES (SURFACE MOUNTING DEVICES)) FOR SHAPE AND DIMENSIONS OF PLASTIC (EMBOSS) TAPE AND REEL.
- F DIMENSION IS PORTION OF THE CORE.

				SCALE	×	PLASTIC TAPE PACKAGED 0.5 mm CONTACT SPACING CONNECTOR	
				DIM. IN	mm	CAT NO.	
				DESIGNED		SFV__R-3STE1	
				DRAWN		DRAWING NO	REV
				CHECKED		JSA 92604	
				APPROVED		DF-136 REV.B	
REV.	DATE	DESCRIPTION	DWN.	APPD.	DATE		

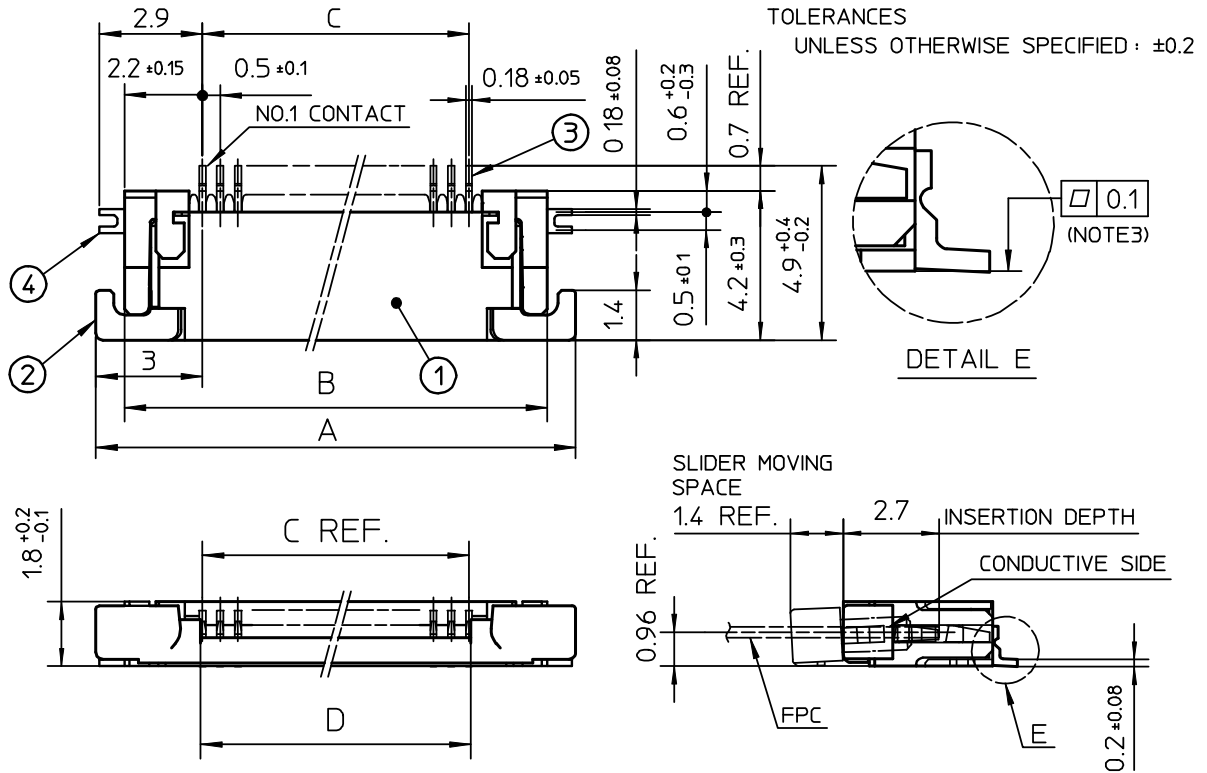

PT. NO.	PARTS NAME	MATERIAL	Q'TY	NOTE
1	HOUSING	POLYAMIDE RESIN GLASS REINFORCED (UL94V-0)	1	COLOR : BLACK
2	SLIDER	PPS RESIN GLASS REINFORCED (UL94V-0)	1	COLOR : BLACK
3	CONTACT	PHOSPHOR BRONZE	n	PLATING : TIN ALLOY
4	MOUNTING PLATE		2	

n : NO. OF CONTACTS

RECOMMENDED PC BOARD LAYOUT
(COMPONENT SIDE)

PATTERN FOR MOUNTING PLATE FIXING

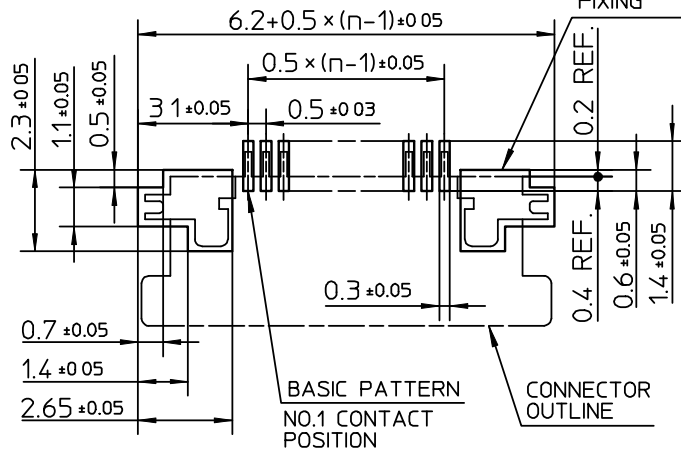

NOTES

1. THIS PRODUCT IS THE CONNECTOR USED FOR FPC AND COPES WITH AUTOMATIC MOUNTING (SMT).
2. THIS PRODUCT IS UPPER CONTACT TYPE CONNECTOR WITH CABLE LOCK MECHANISM.
3. FLATNESS OF CONTACT TERMINAL AND MOUNTING PLATE MUST BE WITHIN TOLERANCE IN E PORTION DETAILED DRAWING.

				SCALE	∞	CONNECTOR USED FOR FPC WITH 05 MM CONTACT SPACING	
				DIM. IN	mm	CAT NO.	
				DESIGNED		SFV__R-4ST__	
				DRAWN		DRAWING NO	REV
				CHECKED		JSA 92602	
				APPROVED			
REV.	DATE	DESCRIPTION	DWN.	APPD.	DATE		

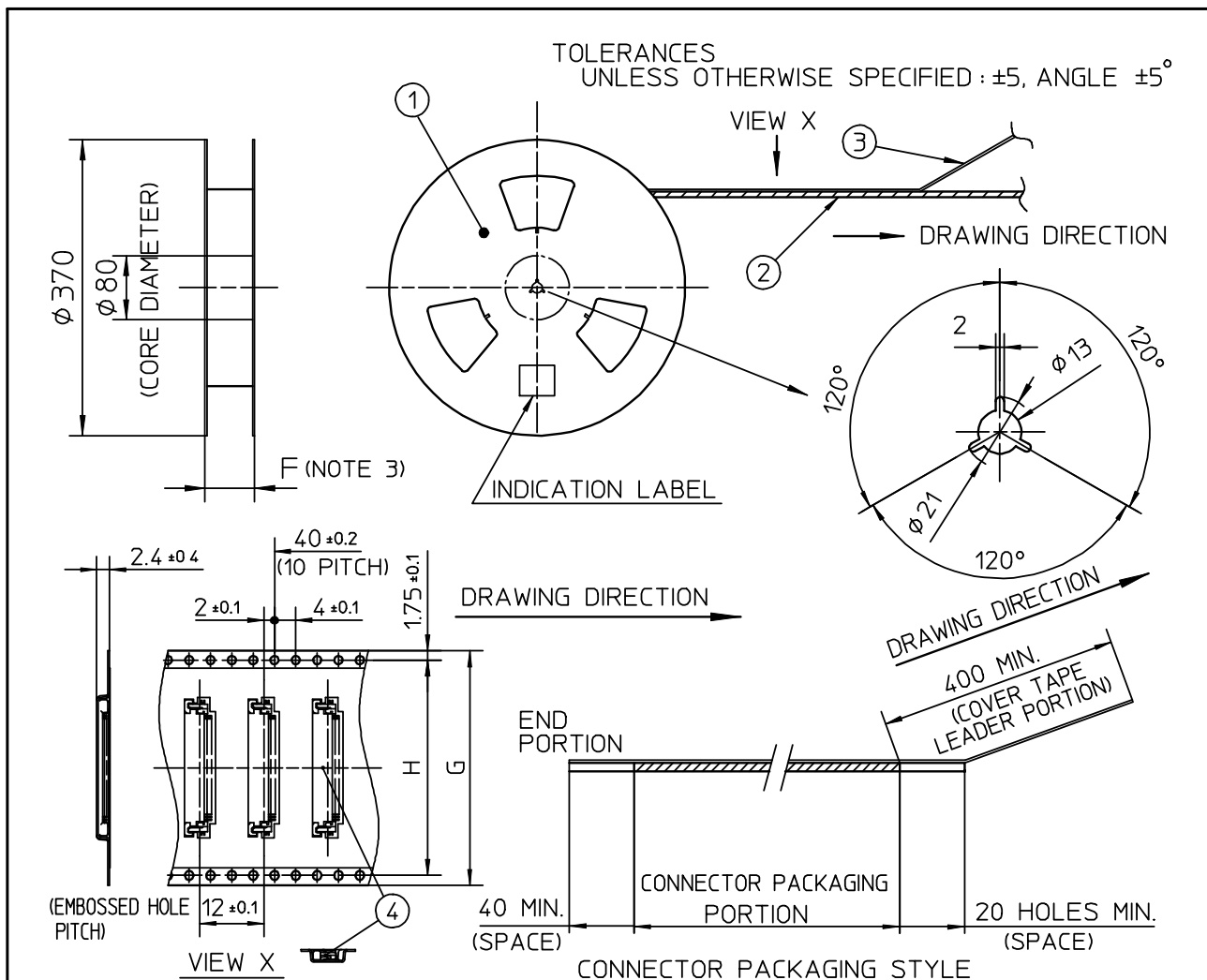

PT. NO.	PARTS NAME	CAT. NO.	MATERIAL	Q'TY	NOTE
1	REEL	_____	CARDBOARD	1	COLOR : WHITE
2	PLASTIC (EMBOSS) TAPE	_____	A-PET	—	COLOR : TRANSPARENCY
3	COVER	_____	POLYESTER	—	COLOR : TRANSPARENCY
4	CONNECTOR	SFV__R-4ST__	SEE ATTACHED DWG.	3000	UPPER CONTACT TYPE WITH CABLE LOCK MECHANISM

NOTES

- THIS IS PLASTIC TAPE PACKAGED CONNECTOR USED FOR FPC AND COPES WITH AUTOMATIC MOUNTING (SMT).
- SEE JIS C 0806 (PACKING OF ELECTRONIC COMPONENTS ON CONTINUOUS TAPES (SURFACE MOUNTING DEVICES)) FOR SHAPE AND DIMENSIONS OF PLASTIC (EMBOSS) TAPE AND REEL.
- F DIMENSION IS PORTION OF THE CORE.

					SCALE	\times	PLASTIC TAPE PACKAGED 05 mm CONTACT SPACING CONNECTOR	
					DIM. IN	mm	CAT NO.	
					DESIGNED		SFV__R-4STE1	
					DRAWN		DRAWING NO	REV
					CHECKED		JSA 92605	
					APPROVED			
REV.	DATE	DESCRIPTION	DWN.	APPD.	DATE			
								DF-136 REV.B

RECOMMENDED CABLE (FPC)

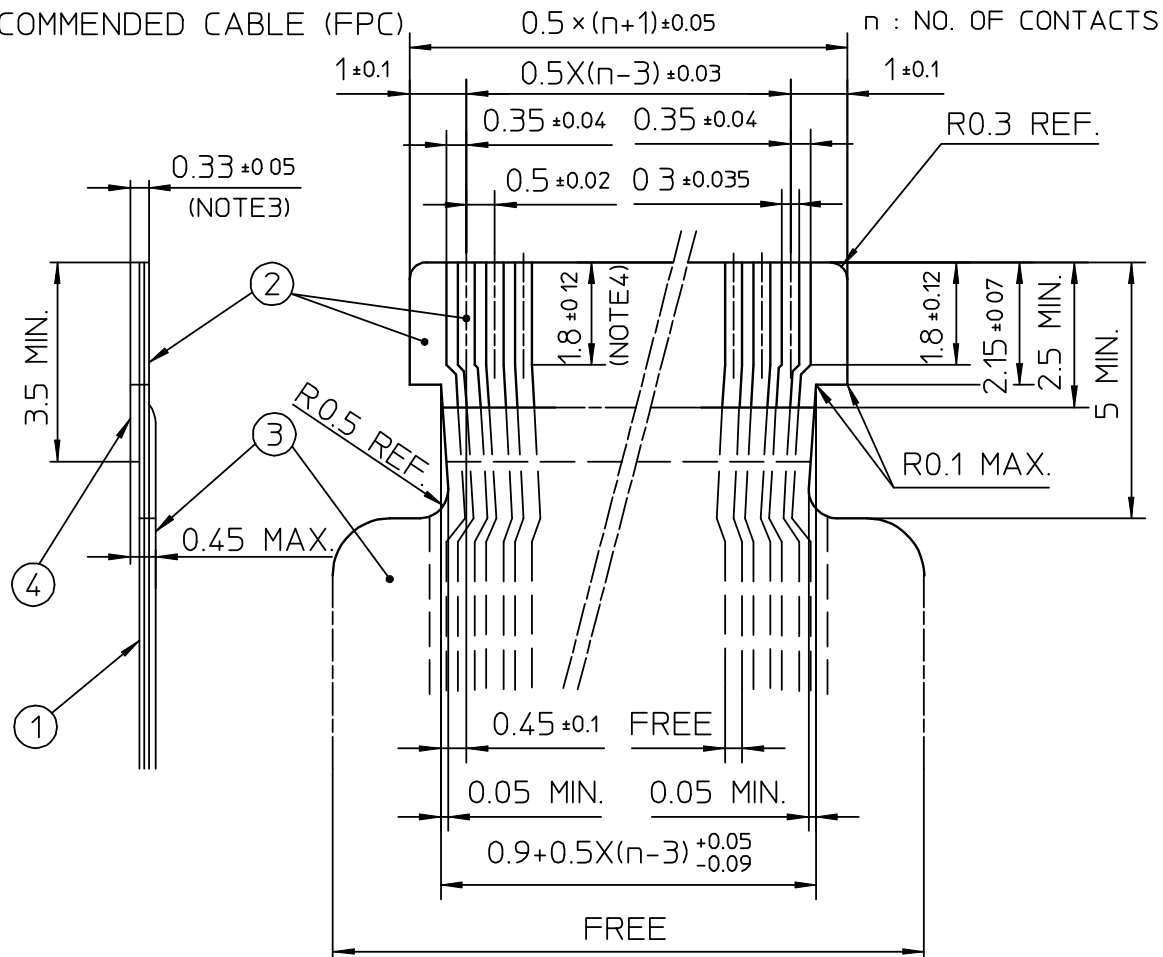

PT. NO.	PARTS NAME	MATERIAL	THICKNESS(μm)
1	BASE FILM	POLYIMIDE OR POLYESTER OR EQUAL	25
2	CONDUCTOR	COPPER FOIL(PLATING : SOLDER 1μm MIN.)	35
3	OVERLAY	POLYIMIDE OR POLYESTER OR EQUAL	—
4	SUPPORTING TAPE	POLYESTER OR POLYIMIDE OR EQUAL	188

NOTES

1. NO BURR AT EACH PORTION.
2. NO PEELING IN COMMON USE.
3. TOTAL THICKNESS LIMIT OF EACH MATERIAL (INCLUDING ADHESIVE AGENT) IS SPECIFIED.
4. THIS DIMENSION INDICATES THE RANGE FOR 0.3 ± 0.035 CONDUCTOR WIDTH.

				SCALE	×	RECOMMENDED CABLE	
				DIM. IN	mm	CAT NO.	
				DESIGNED		SFV__R-3/4ST__	
				DRAWN		DRAWING NO	REV
				CHECKED		JSA 92606	
				APPROVED		 DF-136 REV.B	
REV.	DATE	DESCRIPTION	DWN. APPD.	DATE			