

ADM803/ADM809/ADM810

FEATURES

- Specified over Temperature
- Low Power Consumption (17 μ A)
- Precision Voltage Monitor: 2.5 V, 3 V, 3.3 V, 5 V Options
- Reset Assertion Down to 1 V V_{CC}
- 140 ms Min Power-On Reset
 - Open-Drain $\overline{\text{RESET}}$ Output (ADM803)
 - Push-Pull $\overline{\text{RESET}}$ Output (ADM809)
 - Push-Pull RESET Output (ADM810)
- SC70 and SOT-23 Packages

APPLICATIONS

- Microprocessor Systems
- Computers
- Controllers
- Intelligent Instruments
- Automotive Systems

GENERAL DESCRIPTION

The ADM803/ADM809/ADM810 supervisory circuits monitor the power supply voltage in microprocessor systems. They provide a reset output during power-up, power-down, and brownout conditions. On power-up, an internal timer holds reset asserted for 240 ms. This holds the microprocessor in a reset state until conditions have stabilized. The $\overline{\text{RESET}}$ output remains operational with V_{CC} as low as 1 V. The ADM803 and ADM809 provide an active low reset signal ($\overline{\text{RESET}}$), while the ADM810 provides an active high signal (RESET) output. The ADM809 and ADM810 have push-pull outputs, whereas the ADM803 has an open-drain output, which requires an external pull-up resistor.

Seven reset threshold voltage options are available, suitable for monitoring a variety of supply voltages. Refer to Table I.

The reset comparator features built-in glitch immunity, making it immune to fast transients on V_{CC} .

The ADM803/ADM809/ADM810 consume only 17 μ A, making them suitable for low power, portable equipment. The ADM803 is available in a 3-lead SC70; the ADM809/ADM810 is available in 3-lead SOT-23 and SC70 packages.

FUNCTIONAL BLOCK DIAGRAM

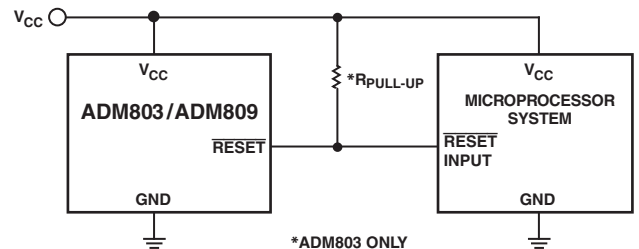
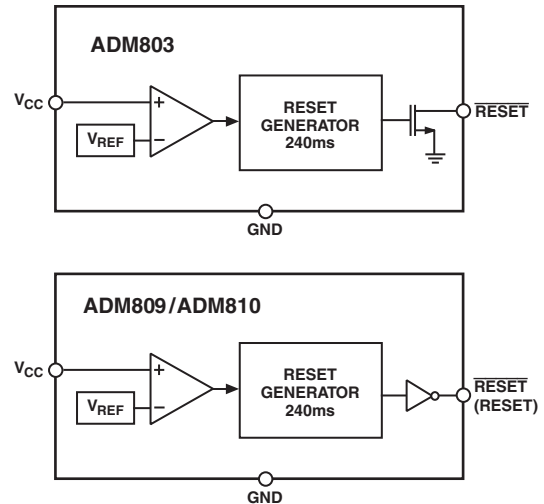

Figure 1. Typical Operating Circuit

REV. F

Information furnished by Analog Devices is believed to be accurate and reliable. However, no responsibility is assumed by Analog Devices for its use, nor for any infringements of patents or other rights of third parties that may result from its use. No license is granted by implication or otherwise under any patent or patent rights of Analog Devices. Trademarks and registered trademarks are the property of their respective owners.

ADM803/ADM809/ADM810—SPECIFICATIONS (V_{CC} = full operating range, $T_A = T_{MIN}$ to T_{MAX} , V_{CC} Typ = 5 V for L/M/J models, 3.3 V for T/S models, 3 V for R models, 2.5 V for Z models, unless otherwise noted.)

Parameter	Min	Typ	Max	Unit	Test Conditions/Comments
V_{CC} OPERATING VOLTAGE RANGE	1.0		5.5	V	$T_A = 0^\circ\text{C}$ to 70°C
Supply Current	1.2		5.5	V	$T_A = -40^\circ\text{C}$ to $+125^\circ\text{C}$
		24	35	μA	$V_{CC} < 5.5$ V, ADM8_L/M/J, $T_A = -40^\circ\text{C}$ to $+85^\circ\text{C}$
		17	30	μA	$V_{CC} < 3.6$ V, ADM8_R/S/T/Z, $T_A = -40^\circ\text{C}$ to $+85^\circ\text{C}$
			60	μA	$V_{CC} < 5.5$ V, ADM8_L/M/J, $T_A = 85^\circ\text{C}$ to 125°C
			60	μA	$V_{CC} < 3.6$ V, ADM8_R/S/T/Z, $T_A = 85^\circ\text{C}$ to 125°C
RESET THRESHOLD					
Reset Voltage Threshold					
ADM8_L	4.56	4.63	4.70	V	$T_A = 25^\circ\text{C}$
ADM8_L	4.50		4.75	V	$T_A = -40^\circ\text{C}$ to $+85^\circ\text{C}$
ADM8_L	4.44		4.82	V	$T_A = -40^\circ\text{C}$ to $+125^\circ\text{C}$
ADM8_M	4.31	4.38	4.45	V	$T_A = 25^\circ\text{C}$
ADM8_M	4.25		4.50	V	$T_A = -40^\circ\text{C}$ to $+85^\circ\text{C}$
ADM8_M	4.20		4.56	V	$T_A = -40^\circ\text{C}$ to $+125^\circ\text{C}$
ADM8_J*	3.93	4.00	4.06	V	$T_A = 25^\circ\text{C}$
ADM8_J*	3.89		4.10	V	$T_A = -40^\circ\text{C}$ to $+85^\circ\text{C}$
ADM8_J*	3.80		4.20	V	$T_A = -40^\circ\text{C}$ to $+125^\circ\text{C}$
ADM8_T	3.04	3.08	3.11	V	$T_A = 25^\circ\text{C}$
ADM8_T	3.00		3.15	V	$T_A = -40^\circ\text{C}$ to $+85^\circ\text{C}$
ADM8_T	2.95		3.21	V	$T_A = -40^\circ\text{C}$ to $+125^\circ\text{C}$
ADM8_S	2.89	2.93	2.96	V	$T_A = 25^\circ\text{C}$
ADM8_S	2.85		3.00	V	$T_A = -40^\circ\text{C}$ to $+85^\circ\text{C}$
ADM8_S	2.81		3.05	V	$T_A = -40^\circ\text{C}$ to $+125^\circ\text{C}$
ADM8_R	2.59	2.63	2.66	V	$T_A = 25^\circ\text{C}$
ADM8_R	2.55		2.70	V	$T_A = -40^\circ\text{C}$ to $+85^\circ\text{C}$
ADM8_R	2.52		2.74	V	$T_A = -40^\circ\text{C}$ to $+125^\circ\text{C}$
ADM8_Z	2.28	2.32	2.35	V	$T_A = 25^\circ\text{C}$
ADM8_Z	2.25		2.38	V	$T_A = -40^\circ\text{C}$ to $+85^\circ\text{C}$
ADM8_Z	2.22		2.42	V	$T_A = -40^\circ\text{C}$ to $+125^\circ\text{C}$
RESET THRESHOLD TEMPERATURE COEFFICIENT					
V_{CC} to Reset Delay		30		ppm/ $^\circ\text{C}$	
		20		μs	$V_{CC} = V_{TH}$ to $(V_{TH} - 100$ mV)
RESET ACTIVE TIMEOUT PERIOD					
	140	240	460	ms	$T_A = -40^\circ\text{C}$ to $+85^\circ\text{C}$
	100		840	ms	$T_A = 85^\circ\text{C}$ to 125°C
RESET OUTPUT VOLTAGE LOW (ADM803/ADM809)			0.3	V	$V_{CC} = V_{TH}$ min, $I_{SINK} = 1.2$ mA, ADM803R/S/T/Z, ADM809R/S/T/Z
			0.4	V	$V_{CC} = V_{TH}$ min, $I_{SINK} = 3.2$ mA, ADM803L/M/J, ADM809L/M/J
			0.3	V	$V_{CC} > 1.0$ V, $I_{SINK} = 50$ μA
RESET OUTPUT VOLTAGE HIGH (ADM809)	$0.8 V_{CC}$			V	$V_{CC} > V_{TH}$ max, $I_{SOURCE} = 500$ μA , ADM809R/S/T/Z
	$V_{CC} - 1.5$			V	$V_{CC} > V_{TH}$ max, $I_{SOURCE} = 800$ μA , ADM809L/M/J
RESET OUTPUT VOLTAGE LOW (ADM810)			0.3	V	$V_{CC} = V_{TH}$ min, $I_{SINK} = 1.2$ mA, ADM810R/S/T/Z
			0.4	V	$V_{CC} = V_{TH}$ min, $I_{SINK} = 3.2$ mA, ADM810L/M/J
RESET OUTPUT VOLTAGE HIGH (ADM810)	$0.8 V_{CC}$			V	1.8 V $< V_{CC} < V_{TH}$ min, $I_{SOURCE} = 150$ μA
RESET OPEN-DRAIN OUTPUT Leakage Current (ADM803)			1	μA	$V_{CC} > V_{TH}$, reset de-asserted

*ADM809/ADM810 only.

ADM803/ADM809/ADM810

ABSOLUTE MAXIMUM RATINGS*

($T_A = 25^\circ\text{C}$, unless otherwise noted.)

V_{CC}	-0.3 V to +6 V
RESET, $\overline{\text{RESET}}$	-0.3 V to $V_{CC} + 0.5$ V
Input Current	
V_{CC}	20 mA
Output Current	
RESET, $\overline{\text{RESET}}$ (push-pull)	20 mA
RESET (open drain)	-0.3 V to +6.0 V
Rate of Rise, V_{CC}	100 V/ μs
θ_{JA} Thermal Impedance, SC70	146°C/W
θ_{JA} Thermal Impedance, SOT-23	270°C/W
Lead Temperature (Soldering, 10 sec)	300°C
Vapor Phase (60 sec)	215°C
Infrared (15 sec)	220°C
Storage Temperature Range	-65°C to +150°C

*Stresses above those listed under Absolute Maximum Ratings may cause permanent damage to the device. This is a stress rating only; functional operation of the device at these or any other conditions above those listed in the operational sections of this specification is not implied. Exposure to absolute maximum ratings for extended periods of time may affect device reliability.

Table I. Reset Threshold Options

RESET Model	Threshold (V)
ADM8_L	4.63
ADM8_M	4.38
ADM8_J*	4.00
ADM8_T	3.08
ADM8_S	2.93
ADM8_R	2.63
ADM8_Z	2.32

*ADM809/ADM810 only.

PIN CONFIGURATION

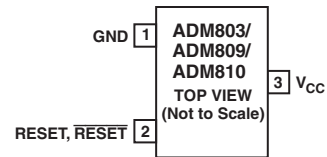

PIN FUNCTION DESCRIPTIONS

Pin No.	Mnemonic	Function
1	GND	0 V. Ground reference for all signals.
2	$\overline{\text{RESET}}$ (ADM803/ADM809)	Active Low Logic Output. $\overline{\text{RESET}}$ remains low while V_{CC} is below the reset threshold and remains low for 240 ms (typ) after V_{CC} rises above the reset threshold.
2	RESET (ADM810)	Active High Logic Output. RESET remains high while V_{CC} is below the reset threshold and remains high for 240 ms (typ) after V_{CC} rises above the reset threshold.
3	V_{CC}	Supply Voltage Being Monitored.

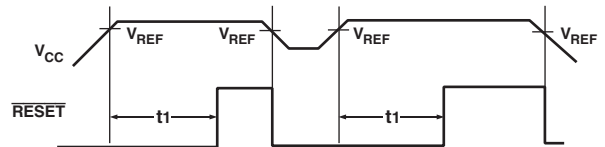

$t_1 = \text{RESET TIME} = 240\text{ms TYP}$
 $V_{REF} = \text{RESET VOLTAGE THRESHOLD}$

Figure 2. Power Fail Reset Timing

CAUTION

ESD (electrostatic discharge) sensitive device. Electrostatic charges as high as 4000 V readily accumulate on the human body and test equipment and can discharge without detection. Although the ADM803/ADM809/ADM810 feature proprietary ESD protection circuitry, permanent damage may occur on devices subjected to high energy electrostatic discharges. Therefore, proper ESD precautions are recommended to avoid performance degradation or loss of functionality.



ADM803/ADM809/ADM810

ORDERING GUIDE

Model	Threshold Reset (V)	Temperature Range	Branding	Quantity	Package Type
ADM803LAKS-REEL	4.63	-40°C to +125°C	M02	10k	3-Lead SC70
ADM803LAKS-REEL7	4.63	-40°C to +125°C	M02	3k	3-Lead SC70
ADM803LAKSZ-REEL ¹	4.63	-40°C to +125°C	M6L	10k	3-Lead SC70
ADM803LAKSZ-REEL7 ¹	4.63	-40°C to +125°C	M6L	3k	3-Lead SC70
ADM803MAKS-REEL	4.38	-40°C to +125°C	M03	10k	3-Lead SC70
ADM803MAKS-REEL7	4.38	-40°C to +125°C	M03	3k	3-Lead SC70
ADM803MAKSZ-REEL ¹	4.38	-40°C to +125°C	M6J	10k	3-Lead SC70
ADM803MAKSZ-REEL7 ¹	4.38	-40°C to +125°C	M6J	3k	3-Lead SC70
ADM803RAKS-REEL	2.63	-40°C to +125°C	M07	10k	3-Lead SC70
ADM803RAKS-REEL7	2.63	-40°C to +125°C	M07	3k	3-Lead SC70
ADM803RAKSZ-REEL ¹	2.63	-40°C to +125°C	M6M	10k	3-Lead SC70
ADM803RAKSZ-REEL7 ¹	2.63	-40°C to +125°C	M6M	3k	3-Lead SC70
ADM803SAKS-REEL	2.93	-40°C to +125°C	M06	10k	3-Lead SC70
ADM803SAKS-REEL7	2.93	-40°C to +125°C	M06	3k	3-Lead SC70
ADM803SAKSZ-REEL ¹	2.93	-40°C to +125°C	M50	10k	3-Lead SC70
ADM803SAKSZ-REEL7 ¹	2.93	-40°C to +125°C	M50	3k	3-Lead SC70
ADM803TAKS-REEL	3.08	-40°C to +125°C	M05	10k	3-Lead SC70
ADM803TAKS-REEL7	3.08	-40°C to +125°C	M05	3k	3-Lead SC70
ADM803TAKSZ-REEL ¹	3.08	-40°C to +125°C	M4M	10k	3-Lead SC70
ADM803TAKSZ-REEL7 ¹	3.08	-40°C to +125°C	M4M	3k	3-Lead SC70
ADM803ZAKS-REEL	2.32	-40°C to +125°C	M08	10k	3-Lead SC70
ADM803ZAKS-REEL7	2.32	-40°C to +125°C	M08	3 k	3-Lead SC70
ADM803ZAKSZ-REEL ¹	2.32	-40°C to +125°C	M6N	10k	3-Lead SC70
ADM803ZAKSZ-REEL7 ¹	2.32	-40°C to +125°C	M6N	3 k	3-Lead SC70
ADM809-5LAKSZ-REEL ¹	2.63	-40°C to +125°C	M6Q	10k	3-Lead SC70
ADM809-5LAKSZ-REEL-RL7 ¹	2.63	-40°C to +125°C	M6Q	3k	3-Lead SC70
ADM809-5LARTZ-REEL ¹	2.63	-40°C to +125°C	M6Q	10k	3-Lead SC70
ADM809-5LARTZ-REEL-RL7 ¹	2.63	-40°C to +125°C	M6Q	3k	3-Lead SC70
ADM809-5SAKSZ-REEL ¹	2.63	-40°C to +125°C	M4C	10k	3-Lead SC70
ADM809-5SAKSZ-REEL-RL7 ¹	2.63	-40°C to +125°C	M4C	3k	3-Lead SC70
ADM809-5SARTZ-REEL ¹	2.63	-40°C to +125°C	M4C	10k	3-Lead SC70
ADM809-5SARTZ-REEL-RL7 ¹	2.63	-40°C to +125°C	M4C	3k	3-Lead SC70
ADM809JAKS-REEL	4.00	-40°C to +125°C	M9C	10k	3-Lead SC70
ADM809JAKS-REEL7	4.00	-40°C to +125°C	M9C	3k	3-Lead SC70
ADM809JAKSZ-REEL ¹	4.00	-40°C to +125°C	M6P	10k	3-Lead SC70
ADM809JAKSZ-REEL7 ¹	4.00	-40°C to +125°C	M6P	3k	3-Lead SC70
ADM809JART-REEL	4.00	-40°C to +125°C	9JXX	10k	3-Lead SOT-23
ADM809JART-REEL7	4.00	-40°C to +125°C	9JXX	3k	3-Lead SOT-23
ADM809JARTZ-REEL ¹	4.00	-40°C to +125°C	M6P	10k	3-Lead SOT-23
ADM809JARTZ-REEL7 ¹	4.00	-40°C to +125°C	M6P	3k	3-Lead SOT-23
ADM809LAKS-REEL	4.63	-40°C to +125°C	M9A	10k	3-Lead SC70
ADM809LAKS-REEL7	4.63	-40°C to +125°C	M9A	3k	3-Lead SC70
ADM809LAKSZ-REEL ¹	4.63	-40°C to +125°C	M6R	10k	3-Lead SC70
ADM809LAKSZ-REEL7 ¹	4.63	-40°C to +125°C	M6R	3k	3-Lead SC70
ADM809LART-REEL	4.63	-40°C to +125°C	9LXX	10k	3-Lead SOT-23
ADM809LART-REEL7	4.63	-40°C to +125°C	9LXX	3k	3-Lead SOT-23
ADM809LARTZ-REEL ¹	4.63	-40°C to +125°C	M6R	10k	3-Lead SOT-23
ADM809LARTZ-REEL7 ¹	4.63	-40°C to +125°C	M6R	3k	3-Lead SOT-23
ADM809MAKS-REEL	4.38	-40°C to +125°C	M9B	10k	3-Lead SC70
ADM809MAKS-REEL7	4.38	-40°C to +125°C	M9B	3k	3-Lead SC70
ADM809MAKSZ-REEL ¹	4.38	-40°C to +125°C	M51	10k	3-Lead SC70
ADM809MAKSZ-REEL7 ¹	4.38	-40°C to +125°C	M51	3k	3-Lead SC70
ADM809MART-REEL	4.38	-40°C to +125°C	9MXX	10k	3-Lead SOT-23
ADM809MART-REEL7	4.38	-40°C to +125°C	9MXX	3k	3-Lead SOT-23
ADM809MARTZ-REEL ¹	4.38	-40°C to +125°C	M51	10k	3-Lead SOT-23
ADM809MARTZ-REEL7 ¹	4.38	-40°C to +125°C	M51	3k	3-Lead SOT-23
ADM809RAKS-REEL	2.63	-40°C to +125°C	M9F	10k	3-Lead SC70
ADM809RAKS-REEL7	2.63	-40°C to +125°C	M9F	3k	3-Lead SC70

ORDERING GUIDE

Model	Threshold Reset (V)	Temperature Range	Branding	Quantity	Package Type
ADM809RAKSZ-REEL ¹	2.63	-40°C to +125°C	M4D	10k	3-Lead SC70
ADM809RAKSZ-REEL7 ¹	2.63	-40°C to +125°C	M4D	3k	3-Lead SC70
ADM809RART-REEL	2.63	-40°C to +125°C	9RXX	10k	3-Lead SOT-23
ADM809RART-REEL7	2.63	-40°C to +125°C	9RXX	3k	3-Lead SOT-23
ADM809RARTZ-REEL ¹	2.63	-40°C to +125°C	M4D	10k	3-Lead SOT-23
ADM809RARTZ-REEL7 ¹	2.63	-40°C to +125°C	M4D	3k	3-Lead SOT-23
ADM809SAKS-REEL	2.93	-40°C to +125°C	M9E	10k	3-Lead SC70
ADM809SAKS-REEL7	2.93	-40°C to +125°C	M9E	3k	3-Lead SC70
ADM809SAKSZ-REEL ¹	2.93	-40°C to +125°C	M53	10k	3-Lead SC70
ADM809SAKSZ-REEL7 ¹	2.93	-40°C to +125°C	M53	3k	3-Lead SC70
ADM809SART-REEL	2.93	-40°C to +125°C	9SXX	10k	3-Lead SOT-23
ADM809SART-REEL7	2.93	-40°C to +125°C	9SXX	3k	3-Lead SOT-23
ADM809SARTZ-REEL ¹	2.93	-40°C to +125°C	M53	10k	3-Lead SOT-23
ADM809SARTZ-REEL7 ¹	2.93	-40°C to +125°C	M53	3k	3-Lead SOT-23
ADM809TAKS-REEL	3.08	-40°C to +125°C	M9D	10k	3-Lead SC70
ADM809TAKS-REEL7	3.08	-40°C to +125°C	M9D	3k	3-Lead SC70
ADM809TAKSZ-REEL ¹	3.08	-40°C to +125°C	M4K	10k	3-Lead SC70
ADM809TAKSZ-REEL7 ¹	3.08	-40°C to +125°C	M4K	3k	3-Lead SC70
ADM809TART-REEL	3.08	-40°C to +125°C	9TXX	10k	3-Lead SOT-23
ADM809TART-REEL7	3.08	-40°C to +125°C	9TXX	3k	3-Lead SOT-23
ADM809TARTZ-REEL ¹	3.08	-40°C to +125°C	M4K	10k	3-Lead SOT-23
ADM809TARTZ-REEL7 ¹	3.08	-40°C to +125°C	M4K	3k	3-Lead SOT-23
ADM809ZAKS-REEL	2.32	-40°C to +125°C	M9G	10k	3-Lead SC70
ADM809ZAKS-REEL7	2.32	-40°C to +125°C	M9G	3k	3-Lead SC70
ADM809ZAKSZ-REEL ¹	2.32	-40°C to +125°C	M4P	10k	3-Lead SC70
ADM809ZAKSZ-REEL ¹	2.32	-40°C to +125°C	M4P	3k	3-Lead SC70
ADM809ZAKSZ-REEL7 ¹	2.32	-40°C to +125°C	M4P	10k	3-Lead SC70
ADM809ZAKSZ-REEL7 ¹	2.32	-40°C to +125°C	M4P	3k	3-Lead SC70
ADM809ZART-REEL	2.32	-40°C to +125°C	9ZXX	10k	3-Lead SOT-23
ADM809ZART-REEL7	2.32	-40°C to +125°C	9ZXX	3k	3-Lead SOT-23
ADM809ZARTZ-REEL ¹	2.32	-40°C to +125°C	M4P	10k	3-Lead SOT-23
ADM809ZARTZ-REEL7 ¹	2.32	-40°C to +125°C	M4P	3k	3-Lead SOT-23
ADM810JAKS-REEL	4.00	-40°C to +125°C	MAC	10k	3-Lead SC70
ADM810JAKS-REEL7	4.00	-40°C to +125°C	MAC	3k	3-Lead SC70
ADM810JAKSZ-REEL ¹	4.00	-40°C to +125°C	M6V	10k	3-Lead SC70
ADM810JAKSZ-REEL7 ¹	4.00	-40°C to +125°C	M6V	3k	3-Lead SC70
ADM810JART-REEL	4.00	-40°C to +125°C	AJXX	10k	3-Lead SOT-23
ADM810JART-REEL7	4.00	-40°C to +125°C	AJXX	3k	3-Lead SOT-23
ADM810JARTZ-REEL ¹	4.00	-40°C to +125°C	M6V	10k	3-Lead SOT-23
ADM810JARTZ-REEL7 ¹	4.00	-40°C to +125°C	M6V	3k	3-Lead SOT-23
ADM810LAKS-REEL	4.63	-40°C to +125°C	MAA	10k	3-Lead SC70
ADM810LAKS-REEL7	4.63	-40°C to +125°C	MAA	3k	3-Lead SC70
ADM810LAKSZ-REEL ¹	4.63	-40°C to +125°C	M6W	10k	3-Lead SC70
ADM810LAKSZ-REEL7 ¹	4.63	-40°C to +125°C	M6W	3k	3-Lead SC70
ADM810LART-REEL	4.63	-40°C to +125°C	ALXX	10k	3-Lead SOT-23
ADM810LART-REEL7	4.63	-40°C to +125°C	ALXX	3k	3-Lead SOT-23
ADM810LARTZ-REEL ¹	4.63	-40°C to +125°C	M6W	10k	3-Lead SOT-23
ADM810LARTZ-REEL7 ¹	4.63	-40°C to +125°C	M6W	3k	3-Lead SOT-23
ADM810MAKS-REEL	4.38	-40°C to +125°C	MAB	10k	3-Lead SC70
ADM810MAKS-REEL7	4.38	-40°C to +125°C	MAB	3k	3-Lead SC70
ADM810MAKSZ-REEL ¹	4.38	-40°C to +125°C	M6S	10k	3-Lead SC70
ADM810MAKSZ-REEL7 ¹	4.38	-40°C to +125°C	M6S	3k	3-Lead SC70
ADM810MART-REEL	4.38	-40°C to +125°C	AMXX	10k	3-Lead SOT-23
ADM810MART-REEL7	4.38	-40°C to +125°C	AMXX	3k	3-Lead SOT-23
ADM810MARTZ-REEL ¹	4.38	-40°C to +125°C	M6S	10k	3-Lead SOT-23
ADM810MARTZ-REEL7 ¹	4.38	-40°C to +125°C	M6S	3k	3-Lead SOT-23
ADM810RAKS-REEL	2.63	-40°C to +125°C	MAF	10k	3-Lead SC70
ADM810RAKS-REEL7	2.63	-40°C to +125°C	MAF	3k	3-Lead SC70

ADM803/ADM809/ADM810

ORDERING GUIDE

Model	Threshold Reset (V)	Temperature Range	Branding	Quantity	Package Type
ADM810RAKSZ-REEL ¹	2.63	-40°C to +125°C	M52	10k	3-Lead SC70
ADM810RAKSZ-REEL7 ¹	2.63	-40°C to +125°C	M52	3k	3-Lead SC70
ADM810RART-REEL	2.63	-40°C to +125°C	ARXX	10k	3-Lead SOT-23
ADM810RART-REEL7	2.63	-40°C to +125°C	ARXX	3k	3-Lead SOT-23
ADM810RARTZ-REEL ¹	2.63	-40°C to +125°C	M52	10k	3-Lead SOT-23
ADM810RARTZ-REEL7 ¹	2.63	-40°C to +125°C	M52	3k	3-Lead SOT-23
ADM810SAKS-REEL	2.93	-40°C to +125°C	MAE	10k	3-Lead SC70
ADM810SAKS-REEL7	2.93	-40°C to +125°C	MAE	3k	3-Lead SC70
ADM810SAKSZ-REEL ¹	2.93	-40°C to +125°C	M6T	10k	3-Lead SC70
ADM810SAKSZ-REEL7 ¹	2.93	-40°C to +125°C	M6T	3k	3-Lead SC70
ADM810SART-REEL	2.93	-40°C to +125°C	ASXX	10k	3-Lead SOT-23
ADM810SART-REEL7	2.93	-40°C to +125°C	ASXX	3k	3-Lead SOT-23
ADM810SARTZ-REEL ¹	2.93	-40°C to +125°C	M6T	10k	3-Lead SOT-23
ADM810SARTZ-REEL7 ¹	2.93	-40°C to +125°C	M6T	3k	3-Lead SOT-23
ADM810TAKS-REEL	3.08	-40°C to +125°C	MAD	10k	3-Lead SC70
ADM810TAKS-REEL7	3.08	-40°C to +125°C	MAD	3k	3-Lead SC70
ADM810TAKSZ-REEL ¹	3.08	-40°C to +125°C	M4V	10k	3-Lead SC70
ADM810TAKSZ-REEL7 ¹	3.08	-40°C to +125°C	M4V	3k	3-Lead SC70
ADM810TART-REEL	3.08	-40°C to +125°C	ATXX	10k	3-Lead SOT-23
ADM810TART-REEL7	3.08	-40°C to +125°C	ATXX	3k	3-Lead SOT-23
ADM810TARTZ-REEL ¹	3.08	-40°C to +125°C	M4V	3k	3-Lead SOT-23
ADM810TARTZ-REEL7 ¹	3.08	-40°C to +125°C	M4V	3k	3-Lead SOT-23
ADM810ZAKS-REEL	2.32	-40°C to +125°C	MAG	10k	3-Lead SC70
ADM810ZAKS-REEL7	2.32	-40°C to +125°C	MAG	3k	3-Lead SC70
ADM810ZAKSZ-REEL ¹	2.32	-40°C to +125°C	M6U	10k	3-Lead SC70
ADM810ZAKSZ-REEL7 ¹	2.32	-40°C to +125°C	M6U	3k	3-Lead SC70
ADM810ZART-REEL	2.32	-40°C to +125°C	AZXX	10k	3-Lead SOT-23
ADM810ZART-REEL7	2.32	-40°C to +125°C	AZXX	3k	3-Lead SOT-23
ADM810ZARTZ-REEL ¹	2.32	-40°C to +125°C	M6U	10k	3-Lead SOT-23
ADM810ZARTZ-REEL7 ¹	2.32	-40°C to +125°C	M6U	3k	3-Lead SOT-23

¹Z = Pb-free part.

Typical Performance Characteristics—ADM803/ADM809/ADM810

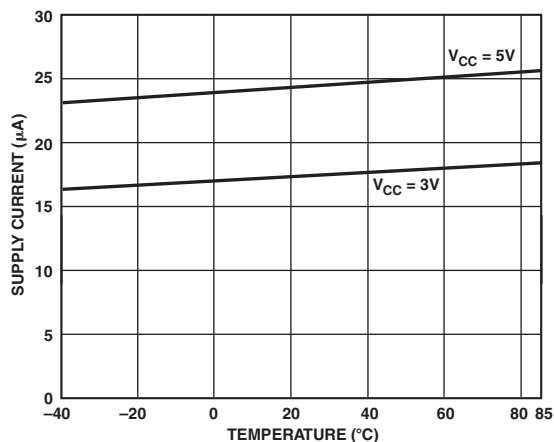

TPC 1. Supply Current vs. Temperature (No Load)

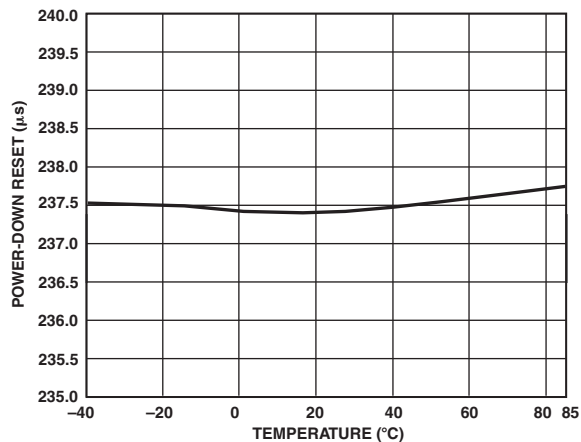

TPC 4. Power-Down RESET Delay vs. Temperature ADM8_R

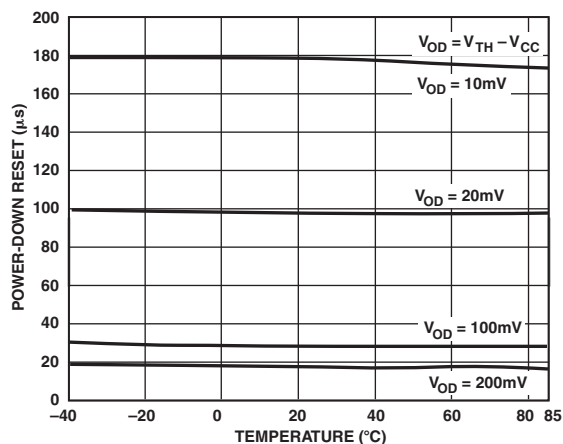

TPC 2. Power-Down RESET Delay vs. Temperature ADM8_L/M/J

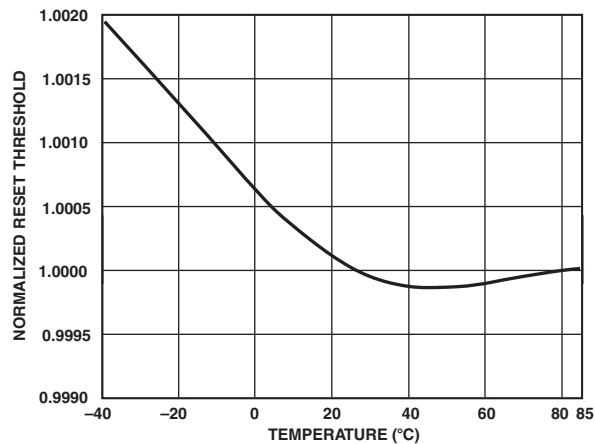

TPC 5. Normalized RESET Voltage Threshold vs. Temperature

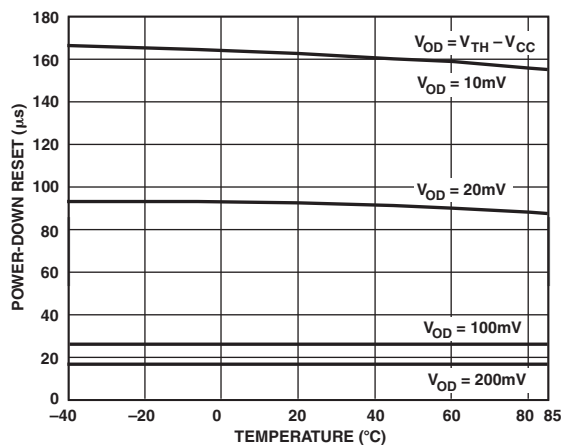

TPC 3. Power-Down RESET Delay vs. Temperature ADM8_T/S/R/Z

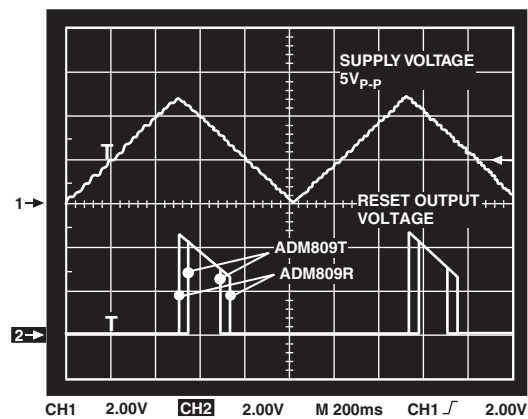

TPC 6. RESET Output Voltage vs. Supply Voltage

ADM803/ADM809/ADM810

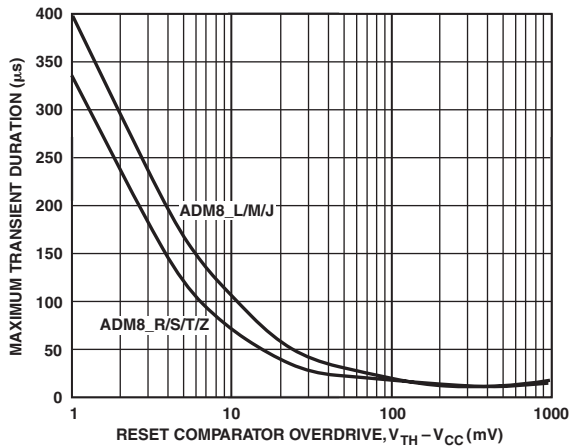

TPC 7. Maximum Transient Duration Without Causing a Reset Pulse vs. Reset Comparator Overdrive

INTERFACING TO OTHER DEVICES' OUTPUT

The ADM803/ADM809/ADM810 series is designed to integrate with as many devices as possible and, therefore, has a standard output dependent on V_{CC} . This enables the parts to be used in both 3 V and 5 V, or any nominal voltage within the minimum and maximum specifications for V_{CC} . This design simplifies interfacing this device to other devices.

Ensuring a Valid Reset Output Down to $V_{CC} = 0 V$

When V_{CC} falls below 0.8 V, the ADM803/ADM809 $\overline{\text{RESET}}$ no longer sinks current. A high impedance CMOS logic input connected to $\overline{\text{RESET}}$ may, therefore, drift to undetermined logic levels. To eliminate this problem, a 100 k Ω resistor should be connected from $\overline{\text{RESET}}$ to ground.

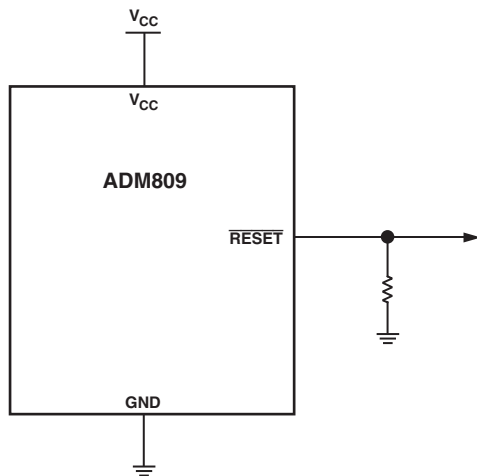

Figure 3. Ensuring a Valid Reset Output Down to $V_{CC} = 0 V$

Benefits of an Accurate Reset Threshold

In other microprocessor supervisory circuits, tolerances in supply voltages lead to an overall increase in reset tolerance levels due to the deterioration of the microprocessor reset circuit's power supply. The possibility of a malfunction during a power failure is greatly reduced because the ADM803/ADM809/ADM810 series can operate effectively even when there are large degradations of the supply voltages. Another advantage of the ADM803/ADM809/ADM810 series is its very accurate internal voltage reference circuit. These benefits combine to produce an exceptionally reliable voltage monitor circuit.

Interfacing to Microprocessors with Multiple Interrupts

In a number of cases, it is necessary to interface many interrupts from different devices (for example, thermal, altitude, and velocity sensors). The ADM803/ADM809/ADM810 can easily be integrated into existing interrupt-handling circuits, as shown in Figure 4, or can be used as a standalone device.

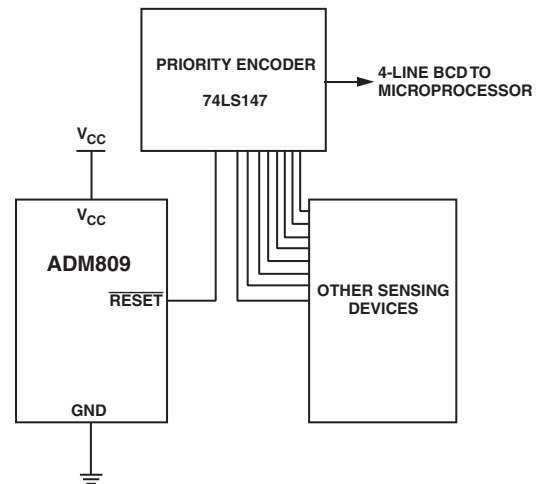

Figure 4. Interfacing to Microprocessors with Multiple Interrupts

ADM803/ADM809/ADM810

Revision History

Location	Page
6/05—Data Sheet changed from REV. E to REV. F.	
Changes to ORDERING GUIDE	4
Updated OUTLINE DIMENSIONS	9
2/05—Data Sheet changed from REV. D to REV. E.	
Changes to ORDERING GUIDE	4
2/05—Data Sheet changed from REV. C to REV. D.	
Changes to ORDERING GUIDE	4
Updated OUTLINE DIMENSIONS	8
5/03—Data Sheet changed from REV. B to REV. C.	
Added ADM803	Universal
Changes to FEATURES	1
Changes to GENERAL DESCRIPTION	1
Changes to Figure 1	1
Changes to SPECIFICATIONS	2
Changes to Table I	3
Updated ORDERING GUIDE	4
1/03—Data Sheet changed from REV. A to REV. B.	
Changes to SPECIFICATIONS	2
Changes to Table I	3
Changes to ORDERING GUIDE	4
Changes to TPCs 1–3, and TPC 7	5
Updated OUTLINE DIMENSIONS	7
10/02—Data Sheet changed from REV. 0 to REV. A.	
Addition of SC70 package	Universal
Change to GENERAL DESCRIPTION	1
Changes to SPECIFICATIONS	2
Changes to ABSOLUTE MAXIMUM RATINGS	3
Change to Table I	3
Change to ORDERING GUIDE	4
Change to TPC 1	5
Updated OUTLINE DIMENSIONS	7

