

4

3

2

1

THIS DRAWING IS UNPUBLISHED. RELEASED FOR PUBLICATION JULY, 2006.  
 © COPYRIGHT 2006 BY TYCO ELECTRONICS CORPORATION. ALL RIGHTS RESERVED.

| LOC |     | DIST        |  | REVISIONS |     |      |  |
|-----|-----|-------------|--|-----------|-----|------|--|
| P   | LTR | DESCRIPTION |  | DATE      | DWN | APVD |  |
|     | A   | FIRST ISSUE |  | 31JUL06   | JMS | FWK  |  |

NOTES

- 1 SINGLE PACK IN ACCORDANCE WITH AMP SPEC 107-3275
- 2 100 TRAY PACK IN ACCORDANCE WITH AMP SPEC 107-3275
- 3 Au PLATING
- 4 ELECTRICAL CHARACTERISTICS
  - FREQUENCY RANGE: DC-3GHz
  - NOMINAL IMPEDANCE: 50 OHMS
  - INSULATION RESISTANCE: 5000 MOHMS
  - DIELECTRIC WITHSTAND VOLTAGE: 500V RMS
  - CONTACT RESISTANCE: CENTRE CONTACT 3 mOHMS  
OUTER CONTACT 2 mOHMS
- 5 MECHANICAL CHARACTERISTICS
  - DURABILITY: 50 CYCLES
  - TORQUE SETTING: 0.15-0.20 NM

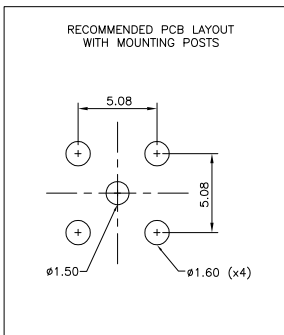
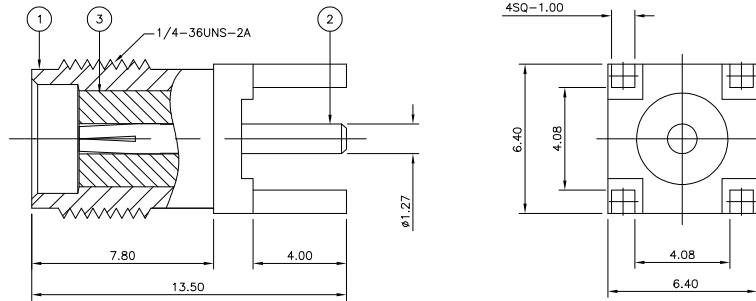

| QTY | DESCRIPTION | MATERIAL        | DESCRIPTION | ITEM |
|-----|-------------|-----------------|-------------|------|
| 1   | 1           | PTFE            | INSULATOR   | 3    |
| 1   | 1           | PHOSPHER BRONZE | SOCKET      | 2    |
| 1   | 1           | ZINC ALLOY      | BODY        | 1    |
| 5   | 15          | MATERIAL        | DESCRIPTION | ITEM |

THIS DRAWING IS A CONTROLLED DOCUMENT.

DWN: J. SANDWELL 31JUL06  
 CHK: S. PARLOW 31JUL06  
 APVD: F. WHEELER-KING 31JUL06

Tyco Electronics Corporation  
 Bideford EX39 4HE

NAME: SMA STRAIGHT PCB SOCKET DIE CAST

SIZE: A3 CAGE CODE: 00779 DRAWING NO: 1814832

RESTRICTED TO: -

SCALE: NTS SHEET: 1 OF 1 REV: A

CUSTOMER DRAWING