

ADVANCED COMMUNICATIONS & SENSING

SX1507/SX1508/SX1509

World's Lowest Voltage Level Shifting GPIO with LED Driver and Keypad Engine

GENERAL DESCRIPTION

The SX1507, SX1508 and SX1509 are complete ultra low voltage 1.2V to 3.6V General Purpose parallel Input/Output (GPIO) expanders ideal for low power handheld battery powered equipment. This family of GPIOs comes in 4-, 8-, 16-channel configuration and allows easy serial expansion of I/O through a standard 400kHz I²C interface. GPIO devices can provide additional control and monitoring when the microcontroller or chipset has insufficient I/O ports, or in systems where serial communication and control from a remote location is advantageous.

These devices can also act as a level shifter to connect a microcontroller running at one voltage level to a component running at a different voltage level, thus eliminating the need for extra level translating circuits. The core is operating as low as 1.425V while the dual I/O banks can operate between 1.2V and 3.6V independent of the core voltage and each other (5.5V tolerant).

The SX1507, SX1508 and SX1509 feature a fully programmable LED Driver with internal oscillator for enhanced lighting control such as intensity (via 256-step PWM), blinking and breathing (fade in/out) make them highly versatile for a wide range of LED applications.

In addition, keypad application is also supported with the on-chip scanning engine which enables continuous keypad monitoring up to 64 keys without any additional host interaction and further reduce the bus activity.

The SX1507, SX1508 and SX1509 have the ability to generate mask-programmable interrupts based on falling/rising edge of any of its GPIO lines. A dedicated pin indicates to a host controller that a state change occurred in one or more of the lines. Each GPIO is programmable via 8-bit configuration registers such as data registers, direction registers, pull-up/pull-down registers, interrupt mask registers and interrupt registers. These I/O expanders come in small footprint packages and are rated from -40°C to +85°C temperature range.

ORDERING INFORMATION

Part Number	I/O Channels	Package
SX1507XXX ⁽¹⁾	4	QFN-UT-14
SX1508IULTRT	8	QFN-UT-20
SX1509IULTRT	16	QFN-UT-28
SX1508EVK	8	Evaluation Kit
SX1509EVK	16	Evaluation Kit

(1) Future product

KEY PRODUCT FEATURES

- 1.2V to 3.6V Low Operating Voltage with Dual Independent I/O Rails (VCC1, VCC2)
 - Enable Direct Level Shifting Between I/O Banks and Host Controller
- 5.5V Tolerant I/Os, Up to 15mA Output Sink on All I/Os (No Total Sink Current Limit)
- Integrated LED Driver for Enhanced Lighting
 - Intensity Control (256-step PWM)
 - Blink Control (224 On/Off values)
 - Breathing Control (224 Fade In/Out values)
- On-Chip Keypad Scanning Engine
 - Support Up to 8x8 Matrix (64 Keys)
 - Configurable Input Debouncer
- 4/8/16 Channels of True Bi-directional Style I/O
 - Programmable Pull-up/Pull-down
 - Push/Pull or Open-drain outputs
 - Programmable Polarity
- Open Drain Active Low Interrupt Output (NINT)
 - Bit Maskable
 - Programmable Edge Sensitivity
- Built-in Clock Management (Internal 2MHz Oscillator/External Clock Input, 7 clock values)
 - OSCIO can be Configured as GPO
- 400kHz I²C Compatible Slave Interface
- 4 User-Selectable I²C Slave Addresses
- Power-On Reset and Reset Input (NRESET)
- Ultra Low Current Consumption of typ. 1uA
- -40°C to +85°C Operating Temperature Range
- 2kV HBM ESD Protection
- Small Footprint Packages
- Pb & Halogen Free, RoHS/WEEE compliant

TYPICAL APPLICATIONS

- Cell phones, PDAs, MP3 players
- Digital camera, Notebooks, GPS Units
- Any battery powered equipment

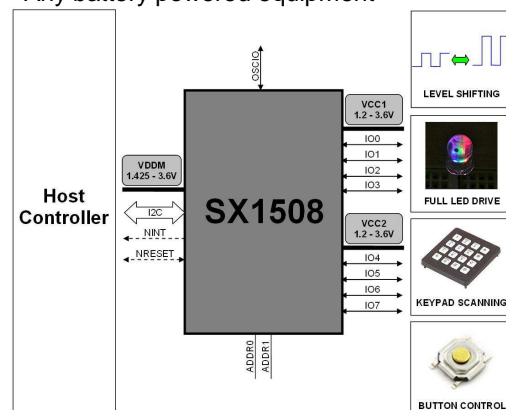

ADVANCED COMMUNICATIONS & SENSING
Table of Contents

GENERAL DESCRIPTION	1
ORDERING INFORMATION.....	1
KEY PRODUCT FEATURES.....	1
TYPICAL APPLICATIONS	1
1 PIN DESCRIPTION	4
1.1 SX1507 4-channel I ² C GPIO with LED Driver	4
1.2 SX1508 8-channel I ² C GPIO with LED Driver and Keypad Engine	5
1.3 SX1509 16-channel I ² C GPIO with LED Driver and Keypad Engine	6
1.4 I/Os Feature Summary	7
2 ELECTRICAL CHARACTERISTICS.....	8
2.1 Absolute Maximum Ratings	8
2.2 Electrical Specifications	8
3 TYPICAL OPERATING CHARACTERISTICS	11
4 BLOCK DETAILED DESCRIPTION.....	12
4.1 SX1507 4-channel I ² C GPIO with LED Driver	12
4.2 SX1508 8-channel I ² C GPIO with LED Driver and Keypad Engine	12
4.3 SX1509 16-channel I ² C GPIO with LED Driver and Keypad Engine	13
4.4 Reset	13
4.4.1 Hardware (NRESET)	13
4.4.2 Software (RegReset)	14
4.5 2-Wire Interface (I ² C)	14
4.5.1 WRITE	14
4.5.2 READ	15
4.6 I/O Banks	15
4.6.1 Input Debouncer	15
4.6.2 Keypad Scanning Engine	16
4.6.3 Level Shifter	16
4.6.4 Polarity Inverter	18
4.7 Interrupt (NINT)	18
4.8 Clock Management	18
4.9 LED Driver	18
4.9.1 Overview	18
4.9.2 Static Mode	19
4.9.3 Single Shot Mode	20
4.9.4 Blink Mode	20
4.9.5 LED Driver Modes	20
4.9.6 Synchronization of LED Drivers across several ICs	21
4.9.7 Tutorial	22
5 CONFIGURATION REGISTERS.....	23
5.1 SX1507 4-channel GPIO with LED Driver	23
5.2 SX1508 8-channel GPIO with LED Driver and Keypad Engine	26
5.3 SX1509 16-channel GPIO with LED Driver and Keypad Engine	30
6 APPLICATION INFORMATION	36
6.1 Typical Application Circuit	36
6.2 Typical LED Connection	36

ADVANCED COMMUNICATIONS & SENSING

7	PACKAGING INFORMATION	37
7.1	QFN-UT 14-pin Outline Drawing	37
7.2	QFN-UT 14-pin Land Pattern	37
7.3	QFN-UT 20-pin Outline Drawing	38
7.4	QFN-UT 20-pin Land Pattern	38
7.5	QFN-UT 28-pin Outline Drawing	39
7.6	QFN-UT 28-pin Land Pattern	39
8	SOLDERING PROFILE	40

ADVANCED COMMUNICATIONS & SENSING

1 PIN DESCRIPTION

1.1 SX1507 4-channel I²C GPIO with LED Driver

Pin	Symbol	Type	Description
X	NRESET	DIO	Active low reset
X	SDA	DIO	I ² C serial data line
X	SCL	DI	I ² C serial clock line
X	ADDR0	DI	Address input bit 0, connect to VDDM or GND
X	ADDR1	DI	Address input bit 1, connect to VDDM or GND
X	NINT	DO	Active low interrupt output
X	OSCIO	DIO	Oscillator input/output, can also be used as GPO
X	VDDM	P	Main supply voltage
X	VCC1	P	I/O supply voltage
X	GND	P	Ground Pin
X	I/O[0]	DIO ^(*)	I/O[0], at power-on configured as an input LED driver : Intensity control (PWM), Blinking
X	I/O[1]	DIO ^(*)	I/O[1], at power-on configured as an input LED driver : Intensity control (PWM), Blinking, Breathing (Fade In/Out)
X	I/O[2]	DIO ^(*)	I/O[2], at power-on configured as an input LED driver : Intensity control (PWM), Blinking, Breathing (Fade In/Out)
X	I/O[3]	DIO ^(*)	I/O[3], at power-on configured as an input LED driver : Intensity control (PWM), Blinking, Breathing (Fade In/Out)

D/I/O/P: Digital/Input/Output/Power

^(*) This pin is programmable through the I²C interface

Table 1 – SX1507 Pin Description

ADVANCED COMMUNICATIONS & SENSING

1.2 SX1508 8-channel I²C GPIO with LED Driver and Keypad Engine

Pin	Symbol	Type	Description
1	NRESET	DIO	Active low reset
2	SDA	DIO	I ² C serial data line
3	SCL	DI	I ² C serial clock line
4	ADDR0	DI	Address input bit 0, connect to VDDM or GND
5	I/O[0]	DIO (*)	I/O[0], at power-on configured as an input LED driver : Intensity control (PWM)
6	I/O[1]	DIO (*)	I/O[1], at power-on configured as an input LED driver : Intensity control (PWM)
7	VCC1	P	Supply voltage for Bank A I/O[3-0]
8	GND	P	Ground Pin
9	I/O[2]	DIO (*)	I/O[2], at power-on configured as an input LED driver : Intensity control (PWM), Blinking
10	I/O[3]	DIO (*)	I/O[3], at power-on configured as an input LED driver : Intensity control (PWM), Blinking, Breathing (Fade In/Out)
11	NINT	DO	Active low interrupt output
12	ADDR1	DI	Address input bit 1, connect to VDDM or GND
13	OSCIO	DIO	Oscillator input/output, can also be used as GPO
14	VDDM	P	Main supply voltage
15	I/O[4]	DIO (*)	I/O[4], at power-on configured as an input LED driver : Intensity control (PWM)
16	I/O[5]	DIO (*)	I/O[5], at power-on configured as an input LED driver : Intensity control (PWM)
17	VCC2	P	Supply voltage for Bank B I/O[7-4]
18	GND	P	Ground Pin
19	I/O[6]	DIO (*)	I/O[6], at power-on configured as an input LED driver : Intensity control (PWM), Blinking
20	I/O[7]	DIO (*)	I/O[7], at power-on configured as an input LED driver : Intensity control (PWM), Blinking, Breathing (Fade In/Out)

D/I/O/P: Digital/Input/Output/Power

(*) This pin is programmable through the I²C interface

Table 2 – SX1508 Pin Description

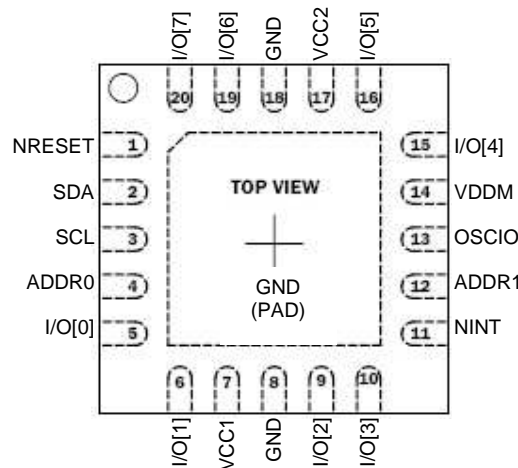

Figure 1 – SX1508 QFN-UT-20 Pinout

ADVANCED COMMUNICATIONS & SENSING

1.3 SX1509 16-channel I²C GPIO with LED Driver and Keypad Engine

Pin	Symbol	Type	Description
1	I/O[2]	DIO (*)	I/O[2], at power-on configured as an input LED driver : Intensity control (PWM), Blinking
2	I/O[3]	DIO (*)	I/O[3], at power-on configured as an input LED driver : Intensity control (PWM), Blinking
3	GND	P	Ground Pin
4	VCC1	P	Supply voltage for Bank A I/O[7-0]
5	I/O[4]	DIO (*)	I/O[4], at power-on configured as an input LED driver : Intensity control (PWM), Blinking, Breathing (Fade In/Out)
6	I/O[5]	DIO (*)	I/O[5], at power-on configured as an input LED driver : Intensity control (PWM), Blinking, Breathing (Fade In/Out)
7	I/O[6]	DIO (*)	I/O[6], at power-on configured as an input LED driver : Intensity control (PWM), Blinking, Breathing (Fade In/Out)
8	I/O[7]	DIO (*)	I/O[7], at power-on configured as an input LED driver : Intensity control (PWM), Blinking, Breathing (Fade In/Out)
9	NINT	DO	Active low interrupt output
10	ADDR1	DI	Address input bit 1, connect to VDDM or GND
11	OSCIO	DO	Oscillator input/output, can also be used as GPO
12	VDDM	P	Main supply voltage
13	I/O[8]	DIO (*)	I/O[8], at power-on configured as an input LED driver : Intensity control (PWM), Blinking
14	I/O[9]	DIO (*)	I/O[9], at power-on configured as an input LED driver : Intensity control (PWM), Blinking
15	I/O[10]	DIO (*)	I/O[10], at power-on configured as an input LED driver : Intensity control (PWM), Blinking
16	I/O[11]	DIO (*)	I/O[11], at power-on configured as an input LED driver : Intensity control (PWM), Blinking
17	GND	P	Ground Pin
18	VCC2	P	Supply voltage for Bank B I/O[15-8]
19	I/O[12]	DIO (*)	I/O[12], at power-on configured as an input LED driver : Intensity control (PWM), Blinking, Breathing (Fade In/Out)
20	I/O[13]	DIO (*)	I/O[13], at power-on configured as an input LED driver : Intensity control (PWM), Blinking, Breathing (Fade In/Out)
21	I/O[14]	DIO (*)	I/O[14], at power-on configured as an input LED driver : Intensity control (PWM), Blinking, Breathing (Fade In/Out)
22	I/O[15]	DIO (*)	I/O[15], at power-on configured as an input LED driver : Intensity control (PWM), Blinking, Breathing (Fade In/Out)
23	NRESET	DIO	Active low reset
24	SDA	DIO	I ² C serial data line
25	SCL	DI	I ² C serial clock line
26	ADDR0	DI	Address input bit 0, connect to VDDM or GND
27	I/O[0]	DIO (*)	I/O[0], at power-on configured as an input LED driver : Intensity control (PWM), Blinking
28	I/O[1]	DIO (*)	I/O[1], at power-on configured as an input LED driver : Intensity control (PWM), Blinking

(*) This pin is programmable through the I²C interface

Table 3 – SX1509 Pin Description

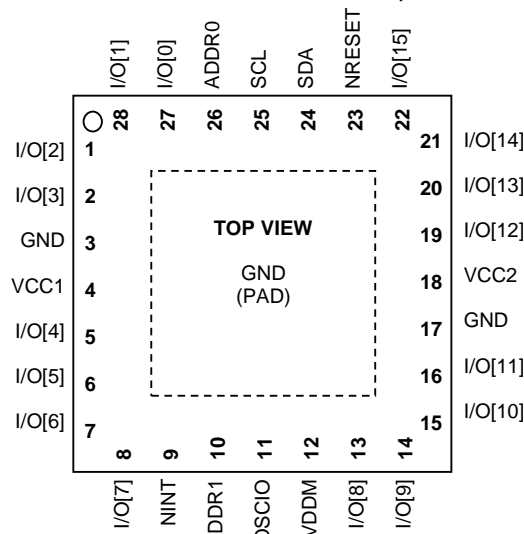

Figure 2 – SX1509 QFN-UT-28 Pinout

ADVANCED COMMUNICATIONS & SENSING

1.4 I/Os Feature Summary

I/O	SX1507			SX1508					SX1509				
	LED Driver			LED Driver			Keypad		LED Driver			Keypad	
	PWM	Blink	Breath	PWM	Blink	Breath	Row	Col.	PWM	Blink	Breath	Row	Col.
0	√	√		√			√		√	√		√	
1	√	√	√	√			√		√	√		√	
2	√	√	√	√	√		√		√	√		√	
3	√	√	√	√	√	√	√		√	√		√	
4				√				√	√	√	√	√	
5				√				√	√	√	√	√	
6				√	√			√	√	√	√	√	
7				√	√	√		√	√	√	√	√	
8									√	√			√
9									√	√			√
10									√	√			√
11									√	√			√
12									√	√	√		√
13									√	√	√		√
14									√	√	√		√
15									√	√	√		√

Table 4 – I/Os Feature Summary

Please note that in addition to table above, all I/Os feature bank-to-bank and bank-to-host level shifting.

ADVANCED COMMUNICATIONS & SENSING

2 ELECTRICAL CHARACTERISTICS

2.1 Absolute Maximum Ratings

Table below applies to SX1508 and SX1509. Stress above the limits listed in the following table may cause permanent failure. Exposure to absolute ratings for extended time periods may affect device reliability. The limiting values are in accordance with the Absolute Maximum Rating System (IEC 134). All voltages are referenced to ground (GND).

Symbol	Description	Min	Max	Unit
V _{max_VDDM}	Main supply voltage	- 0.4	3.7	V
V _{max_VCC1-2}	Digital I/O pin supply voltage	- 0.4	3.7	V
V _{ES_HBM}	Electrostatic handling HBM model ⁽¹⁾ (SX1508)	-	2000	V
	Electrostatic handling HBM model ⁽¹⁾ (SX1509)	-	1500	
V _{ES_CDM}	Electrostatic handling CDM model	-	1000	V
V _{ES_MM}	Electrostatic handling MM model (SX1508)	-	200	V
	Electrostatic handling MM model (SX1509)	-	150	
T _A	Operating ambient temperature range	-40	+85	°C
T _C	Junction temperature range	-40	+125	°C
T _{STG}	Storage temperature range	-55	+150	°C
I _{lat}	Latchup-free input pin current ⁽²⁾	+/-100	-	mA

(1) Tested according to JESD22-A114A

(2) Static latch-up values are valid at maximum temperature according to JEDEC 78 specification

Table 5 - Absolute Maximum Ratings

2.2 Electrical Specifications

Table below applies to SX1508 and SX1509 with default registers values, unless otherwise specified. Typical values are given for T_A = +25°C, VDDM=VCC1=VCC2=3.3V.

Symbol	Description	Conditions	Min	Typ	Max	Unit
Supply						
VDDM	Main supply voltage	-	1.425	-	3.6	V
VCC1,2	I/O banks supply voltage	-	1.2	-	3.6	V
IDD _M	Main supply current (SX1508, I ² C inactive)	Internal osc. OFF	-	1	5	µA
		Internal osc. ON (2MHz)	-	175	235	
		External osc. (32kHz)	-	10	-	
	Main supply current (SX1509, I ² C inactive)	Internal osc. OFF	-	1	5	µA
		Internal osc. ON (2MHz)	-	365	460	
		External osc. (32kHz)	-	10	-	
ICC1,2	I/O banks supply current ⁽¹⁾	-	-	1	2	µA
I/Os set as Input						
VIH	High level input voltage	VCC1,2 >= 2V	0.7* VCC1,2	-	5.5 ⁽⁸⁾	V
		VCC1,2 < 2V	0.8* VCC1,2	-	5.5 ⁽⁸⁾	
VIL	Low level input voltage	VCC1,2 >= 2V	-0.4	-	0.3* VCC1,2	V
		VCC1,2 < 2V	-0.4	-	0.2* VCC1,2	
ILEAK	Input leakage current	Assuming no active pull-up/down	-1	-	1	µA
CI	Input capacitance	-	-	-	10	pF
I/Os set as Output						
VOH	High level output voltage	-	VCC1,2 - 0.3	-	VCC1,2	V
VOL	Low level output voltage	-	-0.4	-	0.3	V
IOH	High level output source current	VCC1,2 >= 2V	-	-	8 ⁽²⁾	mA
		VCC1,2 < 2V	-	-	2 ⁽²⁾	
IOL	Low level output sink current	VCC1,2 >= 2V	-	-	15 ⁽²⁾	mA

ADVANCED COMMUNICATIONS & SENSING

Symbol	Description	Conditions	Min	Typ	Max	Unit
		VCC1,2 < 2V	-	-	8 ⁽²⁾	
t _{PV}	Output data valid timing	Cf. Figure 9	-	-	200	ns
NINT (Output)						
VOL	Low level output voltage	-	-0.4	-	0.3	V
IOL _M	Low level output sink current	VDDM ≥ 2V	-	-	8	mA
		VDDM < 2V	-	-	4	
t _{IV}	Interrupt valid timing	From input data change	-	-	4	μs
t _{IR}	Interrupt reset timing	From RegInterruptSource clearing	-	-	4	μs
NRESET (Input/Output)						
VOL	Low level output voltage	-	-0.4	-	0.3	V
IOL _M	Low level output sink current	VDDM ≥ 2V	-	-	8	mA
		VDDM < 2V	-	-	4	
VIH _{MR}	High level input voltage	VCC1,2 ≥ 2V	0.7* VDDM	-	3.6	V
		VCC1,2 < 2V	0.8* VDDM	-	3.6	
VIL _M	Low level input voltage	VCC1,2 ≥ 2V	-0.4	-	0.3* VDDM	V
		VCC1,2 < 2V	-0.4	-	0.2* VDDM	
ILEAK	Input leakage current	-	-1	-	1	μA
CI	Input capacitance	-	-	-	10	pF
VPOR	Power-On-Reset voltage	Cf. Figure 7	-	0.8	-	V
VDROPH	High brown-out voltage	Cf. Figure 7	-	VDDM-1	-	V
VDROPL	Low brown-out voltage	Cf. Figure 7	-	0.2	-	V
t _{RESET}	Reset time	Cf. Figure 7	0.6	-	2.5	ms
t _{PULSE}	Reset pulse from host uC	Cf. Figure 7	200	-	-	ns
ADDR0, ADDR1 (Inputs)						
VIH _{MA}	High level input voltage	VCC1,2 ≥ 2V	0.7* VDDM	-	VDDM +0.3	V
		VCC1,2 < 2V	0.8* VDDM	-	VDDM +0.3	
VIL _M	Low level input voltage	VCC1,2 ≥ 2V	-0.4	-	0.3* VDDM	V
		VCC1,2 < 2V	-0.4	-	0.2* VDDM	
ILEAK	Input leakage current	-	-1	-	1	μA
CI	Input capacitance	-	-	-	10	pF
OSCIO (Input/Output)						
VIH _{MA}	High level input voltage	VCC1,2 ≥ 2V	0.7* VDDM	-	VDDM +0.3	V
		VCC1,2 < 2V	0.8* VDDM	-	VDDM +0.3	
VIL _M	Low level input voltage	VCC1,2 ≥ 2V	-0.4	-	0.3* VDDM	V
		VCC1,2 < 2V	-0.4	-	0.2* VDDM	
ILEAK	Input leakage current	-	-1	-	1	μA
CI	Input capacitance	-	-	-	10	pF
VOH _M	High level output voltage	-	VDDM - 0.3	-	VDDM	V
VOL	Low level output voltage	-	-0.4	-	0.3	V
IOH _M	High level output source current	VDDM ≥ 2V	-	-	8	mA
		VDDM < 2V	-	-	2	
IOL _M	Low level output sink current	VDDM ≥ 2V	-	-	8	mA
		VDDM < 2V	-	-	4	
SCL (Input) and SDA (Input/Output) ⁽³⁾						

ADVANCED COMMUNICATIONS & SENSING

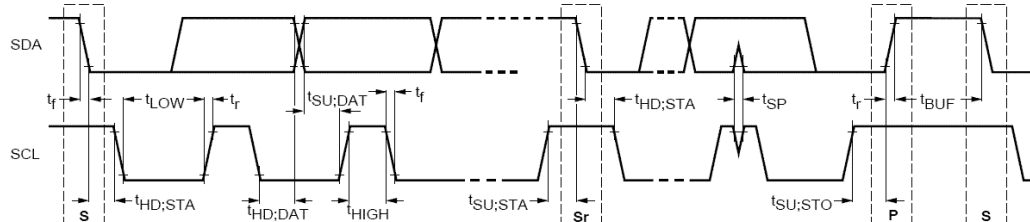
Symbol	Description	Conditions	Min	Typ	Max	Unit
Interface complies with slave F/S mode I ² C interface as described by Philips I ² C specification version 2.1 dated January, 2000. Please refer to that document for more detailed I ² C specifications.						
						
VOL	Low level output voltage	-	-0.4	-	0.3	V
IOL _M	Low level output sink current	VDDM ≥ 2V	-	-	8	mA
		VDDM < 2V	-	-	4	
VIH _{MR}	High level input voltage	VCC1,2 ≥ 2V	0.7* VDDM	-	3.6	V
		VCC1,2 < 2V	0.8* VDDM	-	3.6	
VIL _M	Low level input voltage	VCC1,2 ≥ 2V	-0.4	-	0.3* VDDM	V
		VCC1,2 < 2V	-0.4	-	0.2* VDDM	
f _{SCL}	SCL clock frequency	-	-	-	400	kHz
t _{HD:STA}	Hold time (repeated) START condition	-	0.6	-	-	μs
t _{LOW}	LOW period of the SCL clock	-	1.3	-	-	μs
t _{HIGH}	HIGH period of the SCL clock	-	0.6	-	-	μs
t _{SU:STA}	Set-up time for a repeated START condition	-	0.6	-	-	μs
t _{HD:DAT}	Data hold time	-	0 ⁽⁴⁾	-	0.9 ⁽⁵⁾	μs
t _{SU:DAT}	Data set-up time	-	100 ⁽⁶⁾	-	-	ns
t _r	Rise time of both SDA and SCL	-	20+0.1C _b ⁽⁷⁾	-	300	ns
t _f	Fall time of both SDA and SCL	-	20+0.1C _b ⁽⁷⁾	-	300	ns
t _{SU:STO}	Set-up time for STOP condition	-	0.6	-	-	μs
t _{BUF}	Bus free time between a STOP and START condition	-	1.3	-	-	μs
C _b	Capacitive load for each bus line	-	-	-	400	pF
V _{nL}	Noise margin at the LOW level for each connected device (including hysteresis)	-	-	0.1* VDDM	-	V
V _{nH}	Noise margin at the HIGH level for each connected device (including hysteresis)	-	-	0.2* VDDM	-	V
t _{SP}	Pulse width of spikes suppressed by the input filter	-	-	-	50	ns
Miscellaneous						
RPULL	Programmable pull-up/down resistors for IO[0-7]	-	-	42	-	kΩ
f _{OSC}	Oscillator frequency	Internal	1.3	2	2.6	MHz
		External from OSCIN	-	-	2.6	

(1) Assuming no load connected to outputs and inputs fixed to VCC1,2 or GND.
(2) Can be increased by tying together and driving simultaneously several I/Os.
(3) All values referred to VIH_{MR min} and VIL_{M max} levels.
(4) A device must internally provide a hold time of at least 300ns for the SDA signal (referred to VIH_{MR min}) to bridge the undefined region of the falling edge of SCL.
(5) The maximum t_{HD:DAT} has only to be met if the device does not stretch the LOW period (t_{LOW}) of the SCL signal.
(6) A Fast-mode I²C-bus device can be used in a Standard-mode I²C-bus system, but the requirement t_{SU:DAT} ≥ 250 ns must then be met. This will automatically be the case if the device does not stretch the LOW period of the SCL signal.
If such a device does stretch the LOW period of the SCL signal, it must output the next data bit to the SDA line t_{r max} + t_{SU:DAT} = 1000 + 250 = 1250 ns (according to the Standard-mode I²C-bus specification) before the SCL line is released.
(7) C_b = total capacitance of one bus line in pF. If mixed with Hs-mode devices, faster fall-times are allowed.
(8) With RegHighInput bit enabled (VCCx min = 1.65V), else 3.6V (VCCx min = 1.2V)

Table 6 – Electrical Specifications

ADVANCED COMMUNICATIONS & SENSING

3 TYPICAL OPERATING CHARACTERISTICS

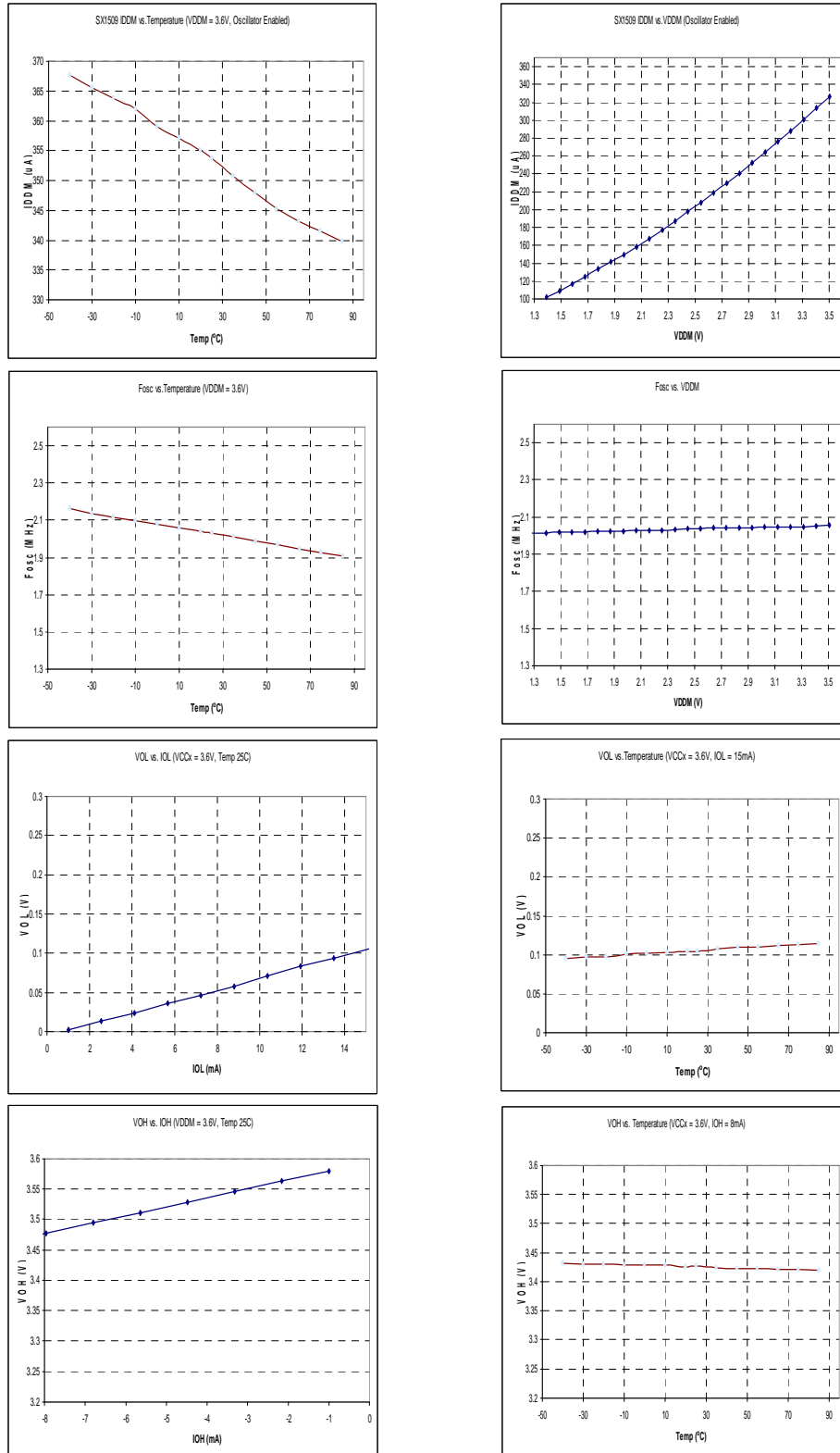

Figure 3 – Typical Operating Characteristics

ADVANCED COMMUNICATIONS & SENSING

4 BLOCK DETAILED DESCRIPTION

4.1 SX1507 4-channel I²C GPIO with LED Driver

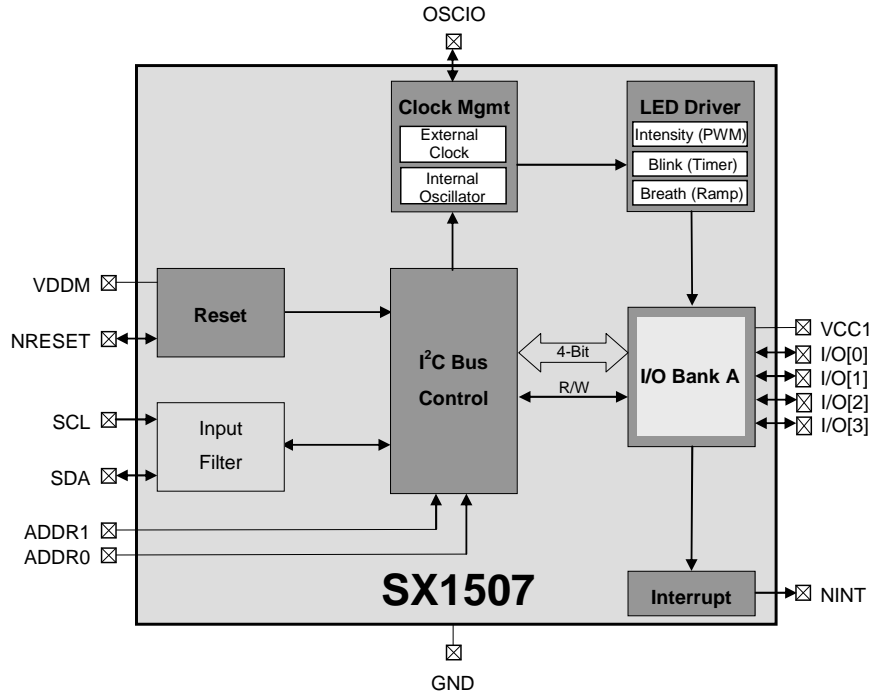

Figure 4 – 4-channel Low Voltage GPIO with LED Driver

4.2 SX1508 8-channel I²C GPIO with LED Driver and Keypad Engine

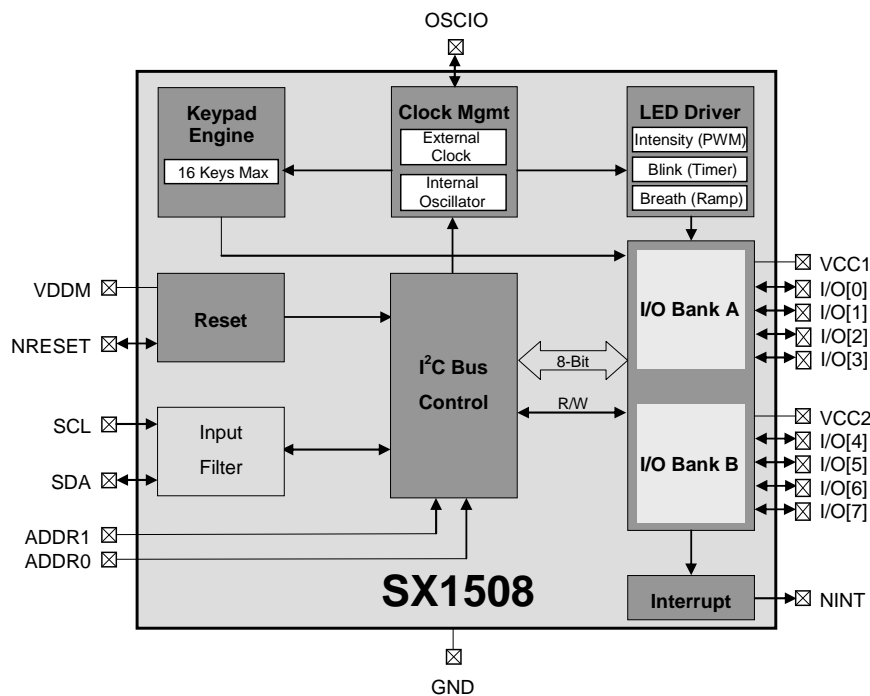

Figure 5 – 8-channel Low Voltage GPIO with LED Driver and Keypad Engine

ADVANCED COMMUNICATIONS & SENSING

4.3 SX1509 16-channel I²C GPIO with LED Driver and Keypad Engine

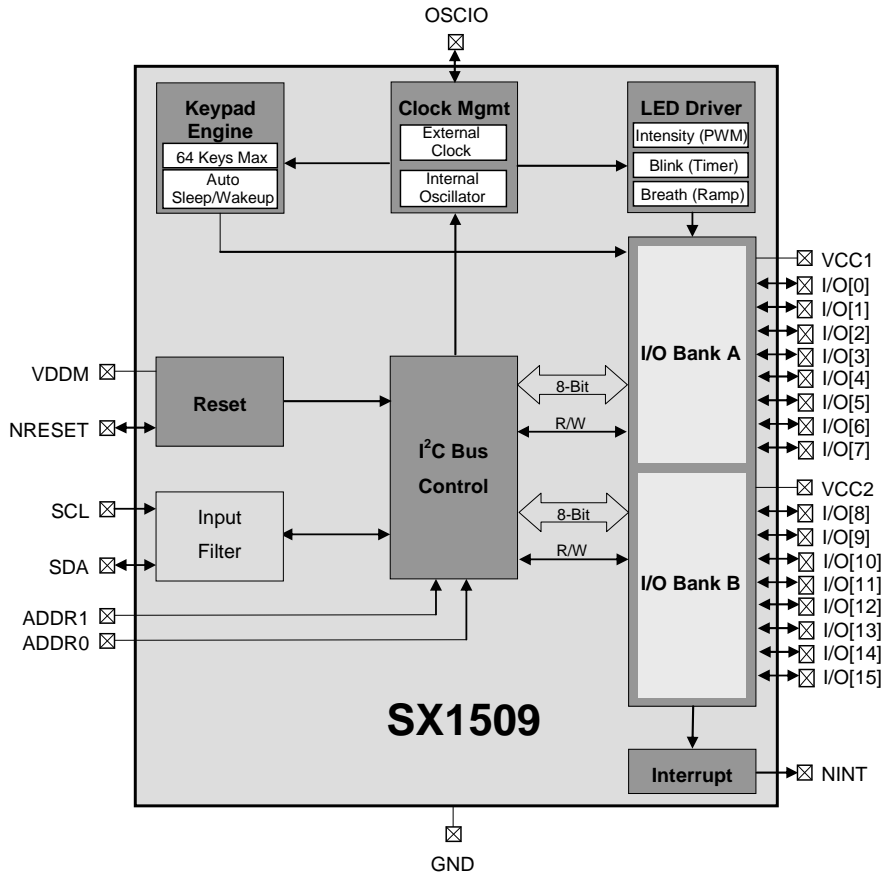

Figure 6 – 16-channel Low Voltage GPIO with LED Driver and Keypad Engine

4.4 Reset

4.4.1 Hardware (NRESET)

The SX1507, SX1508 and SX1509 generate their own power on reset signal after a power supply is connected to the VDDM pin. The reset signal is made available for the user at the pin NRESET. The rising edge of the NRESET indicates that the startup sequence of the SX1507, SX1508 or SX1509 has finished. NRESET must be connected to VDDM (or greater) either directly, or via a resistor.

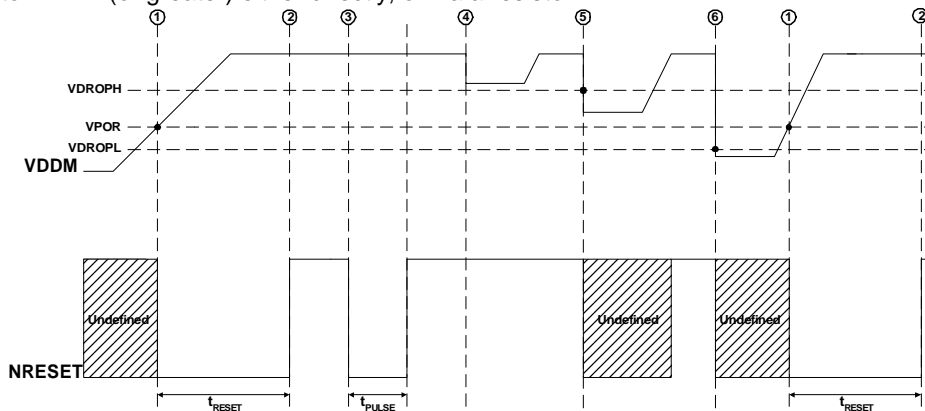

Figure 7 – Power-On / Brown-out Reset Conditions

1. Device behavior is undefined until VDDM rises above VPOR, at which point NRESET is driven to GND by the SX1507, SX1508 or SX1509.
2. After t_{RESET}, NRESET is released (high-impedance) by the SX1507, SX1508 or SX1509 to allow it to be pulled high by an external resistor.

ADVANCED COMMUNICATIONS & SENSING

3. In operation, the SX1507, SX1508 and SX1509 may be reset (POR like or LED driver counters only depending on RegMisc setting) at anytime by an external device driving NRESET low during t_{PULSE} . Chip can be accessed normally again after NRESET rising edge.
4. During a brown-out event, if VDDM drops above VDROPH a reset will not occur.
5. During a brown-out event, if VDDM drops between VDROPH and VDROPL a reset may occur.
6. During a brown-out event, if VDDM drops below VDROPL a reset will occur next time VPOR is crossed.

Please note that a brown-out event is defined as a transient event on VDDM. If VDDM is attached to a battery, then the gradual decay of the battery voltage will not be interpreted as a brown-out event. Please also note that a sharp rise in VDDM ($> 1V/us$) may induce a circuit reset.

4.4.2 Software (RegReset)

Writing consecutively 0x12 and 0x34 to RegReset register will reset all registers to their default values.

4.5 2-Wire Interface (I²C)

The SX1507, SX1508 and SX1509 2-wire interface operates only in slave mode. In this configuration, the device has one or 4 possible devices addresses defined by ADDR[1:0] pins:

Device	ADDR[1:0]	Address	Description
SX1508	00	0x20 (0100000)	First address of the 2-wire interface
	01	0x21 (0100001)	Second address of the 2-wire interface
	10	0x22 (0100010)	Third address of the 2-wire interface
	11	0x23 (0100011)	Fourth address of the 2-wire interface
SX1507 & SX1509	00	0x3E (0111110)	First address of the 2-wire interface
	01	0x3F (0111111)	Second address of the 2-wire interface
	10	0x70 (1110000)	Third address of the 2-wire interface
	11	0x71 (1110001)	Fourth address of the 2-wire interface

Table 7 - 2-Wire Interface Address

2 lines are used to exchange data between an external master host and the slave device:

- **SCL** : Serial CLock
- **SDA** : Serial DAta

The SX1507, SX1508 and SX1509 are read-write slave-mode I²C devices and comply with the Philips I²C standard Version 2.1 dated January, 2000. The SX1507, SX1508 and SX1509 have a few user-accessible internal 8-bits registers to set the various parameters of operation (Cf. §5 for detailed configuration registers description). The I²C interface has been designed for program flexibility, in that once the slave address has been sent to the SX1507, SX1508 or SX1509 enabling it to be a slave transmitter/receiver, any register can be written or read independently of each other. The start and stop commands frame the data-packet and the repeat start condition is allowed if necessary.

Seven bit addressing is used and ten bit addressing is not allowed. Any general call address will be ignored by the SX1507, SX1508 and SX1509. The SX1507, SX1508 and SX1509 are not CBUS compatible and can operate in standard mode (100kbit/s) or fast mode (400kbit/s).

4.5.1 WRITE

After the start condition [S], the slave address (SA) is sent, followed by an eighth bit ('0') indicating a Write. The slave then Acknowledges [A] that it is being addressed, and the Master sends an 8 bit Data Byte consisting of the slave Register Address (RA). The Slave Acknowledges [A] and the master sends the appropriate 8 bit Data Byte (WD0). Again the slave Acknowledges [A]. In case the master needs to write more data, a succeeding 8 bit Data Byte will follow (WD1), acknowledged by the slave [A]. This sequence will be repeated until the master terminates the transfer with the Stop condition [P].

ADVANCED COMMUNICATIONS & SENSING

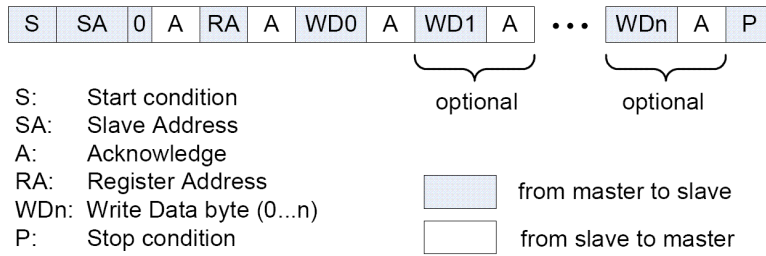

Figure 8 - 2-Wire Serial Interface, Write Operation

When successive register data (WD1...WDn) is supplied by the master, the register address can be automatically incremented or kept fixed depending on the setting programmed in RegMisc.

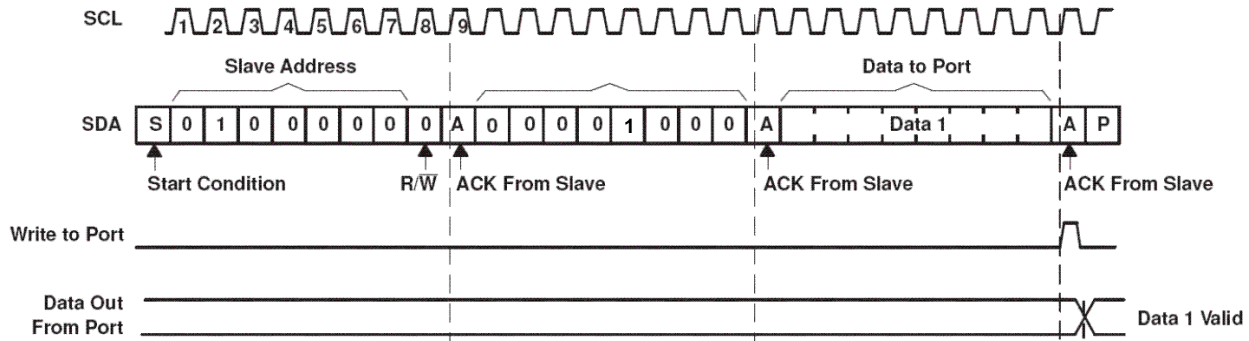

Figure 9 – Example: Write RegData Register

4.5.2 READ

After the start condition [S], the slave address (SA) is sent, followed by an eighth bit ('0') indicating a Write. The slave then Acknowledges [A] that it is being addressed, and the Master responds with an 8 bit Data consisting of the Register Address (RA). The slave Acknowledges [A] and the master sends the Repeated Start Condition [Sr]. Once again, the slave address (SA) is sent, followed by an eighth bit ('1') indicating a Read.

The slave responds with an Acknowledge [A] and the read Data byte (RD0). If the master needs to read more data it will acknowledge [A] and the slave will send the next read byte (RD1). This sequence can be repeated until the master terminates with a NACK [N] followed by a stop [P].

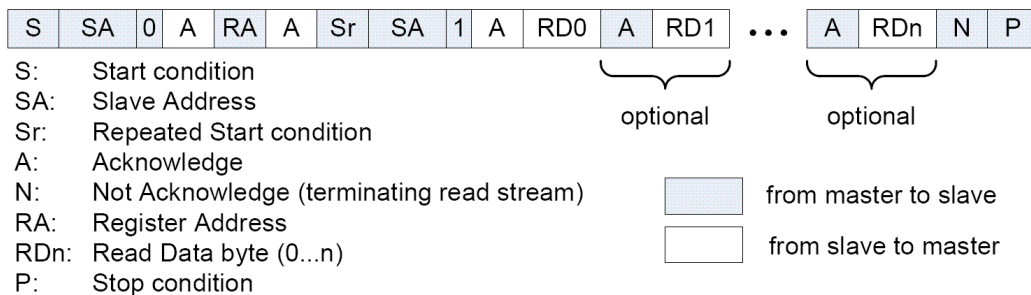

Figure 10 - 2-Wire Serial Interface, Read Operation

When successive register data (RD1...RDn) is read by the master, the register address will be automatically incremented or kept fixed depending on the setting programmed in RegMisc.

4.6 I/O Banks

4.6.1 Input Debouncer

Each input can be individually debounced by setting corresponding bits in RegDebounce register. At power up the debounce function is disabled. After enabling the debouncer, the change of the input value is accepted only if the input value is identical at two consecutive sampling times.

ADVANCED COMMUNICATIONS & SENSING

The debounce time common to all IOs can be set in RegDebounceConfig register from 0.5 to 64ms (fOSC = 2MHz).

4.6.2 Keypad Scanning Engine

SX1508, and SX1509 integrate a fully programmable keypad scanning engine to implement keypad applications up to 8x8 matrix (i.e. 64 keys).

Please note that SX1509 also implements an Auto Sleep/Wakeup feature to save power consumption when no key has been pressed for a programmed time.

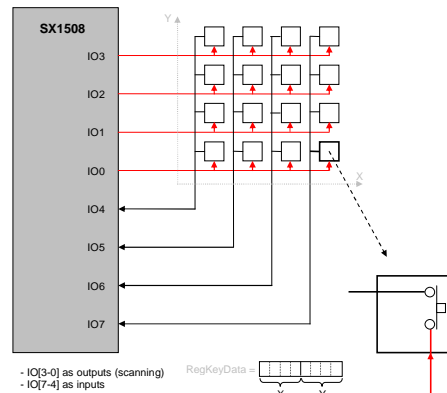

Figure 11 – 4x4 Keypad Connection to SX1508

Following procedure should be implemented on the host controller for a 4x4 keypad:

1. Set RegDir to 0xF0 (IO[3:0] as outputs, IO[7:4] as inputs), set RegOpenDrain to 0x0F (IO[3:0] as open-drain outputs), set RegPullup to 0xF0 (pull-ups enabled on inputs IO[7:4]).
2. Enable and configure debouncing on IO[7:4] (RegDebounceEnable = 0xF0, Ex : RegDebounceConfig = 0x05)
3. Enable and configure keypad scanning engine (Ex : RegKeyConfig = 0x7D) This will start an infinite loop with the following sequence to IO[3:0]: ZZZ0, ZZ0Z, Z0ZZ, 0ZZZ. Make sure that scan interval is set to higher value than the debounce time.
4. When a key is pressed, NINT goes low, key scan is halted and the key coordinates are stored in RegKeyData:
 - The column data will be stored in RegKeyData[7:4] (Note: column indication is active low)
 - The row data will be stored in RegKeyData[3:0] (Note: row indication is active low)
 - When RegKeyData is read, this data along with the interrupt is automatically cleared (same behavior as reading RegData) and the key scan continues to the next row.
5. Restart from point 4.

This implementation allows the host to handle both single and multi-touches easily (fast AAAAAA sequence is a long press of key A, fast ABABABAB sequence is key A and key B pressed together, etc)

4.6.3 Level Shifter

Because of their 5.5V tolerant I/O banks with independent supply voltages between 1.2V and 3.6V, the SX1508 and SX1509 can perform level shifting of signals from one I/O bank to another **without uC activity** by programming the corresponding configuration register bits accordingly in RegLevelShifter (and RegDir).

This can save significant BOM cost in a final application where only a few signals need to be level-shifted (no need for an additional external level shifter IC).

ADVANCED COMMUNICATIONS & SENSING

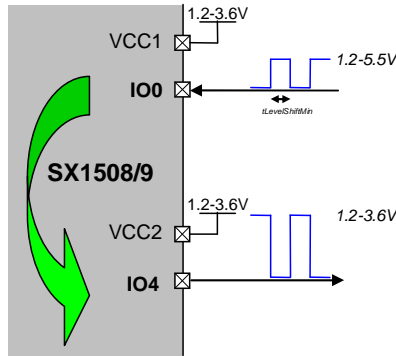

Figure 12 – Level Shifting Example

The minimum pulse width $t_{LevelShiftMin}$ which can be level shifted properly depends on $VCCx$ and $VDDM$:

$$t_{LevelShiftMin} = \text{Input Delay} + \text{Core Delay} + \text{Output Delay}$$

Input/Core/Output delays vs $VCCx/VDDM$ are given in figures below.

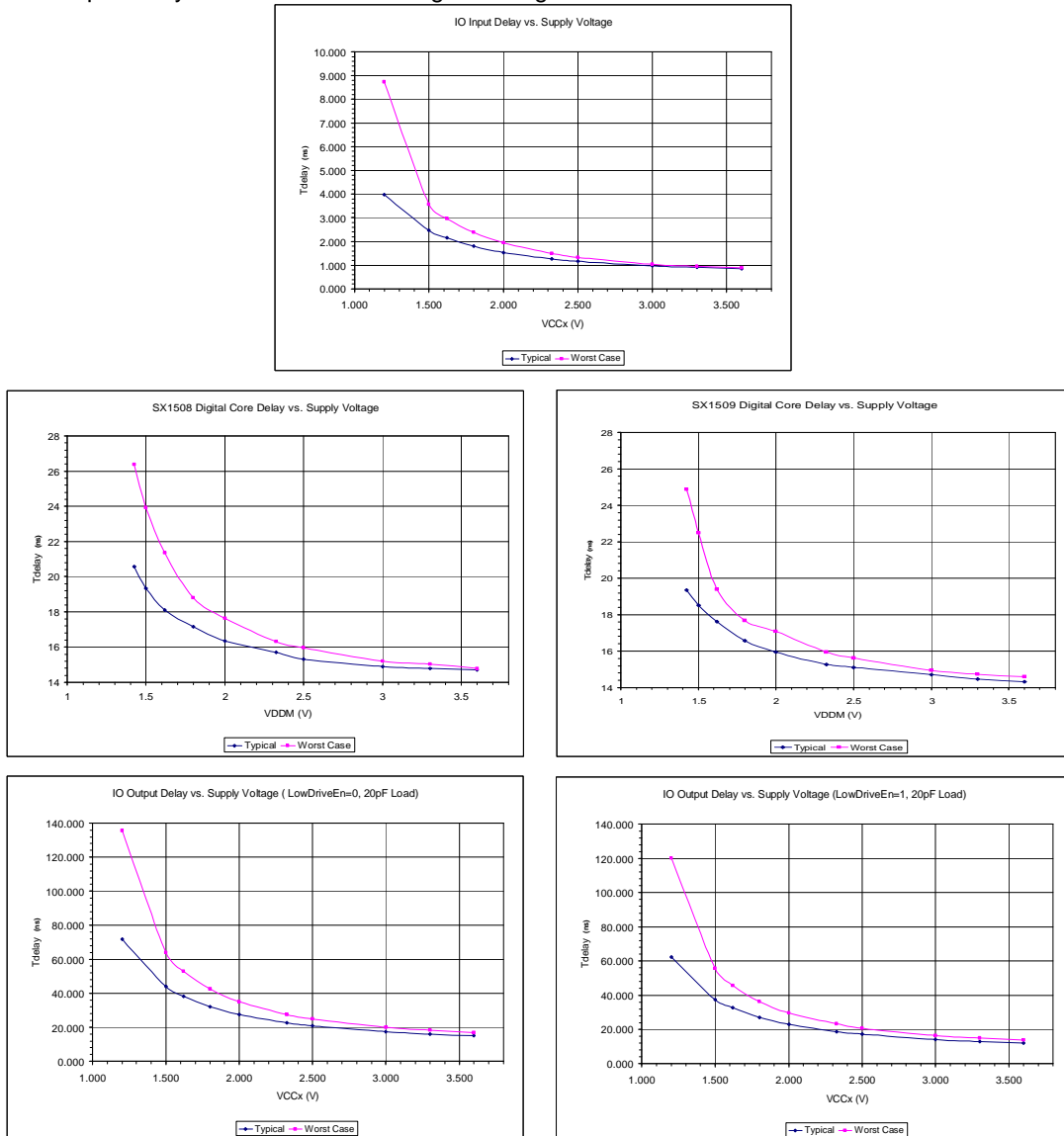

Figure 13 – Level Shifter Max Frequency Calculation Data

ADVANCED COMMUNICATIONS & SENSING

4.6.4 Polarity Inverter

Each IO's polarity can be individually inverted by setting corresponding bit in RegPolarity register. Please note that polarity inversion can also be combined with level shifting feature.

4.7 Interrupt (NINT)

At start-up, the transition detection logic is reset, and NINT is released to a high-impedance state. The interrupt mask register is set to 0xFF, disabling the interrupt output for transitions on all I/O ports. The transition flags are cleared to indicate no data changes.

An interrupt NINT can be generated on any programmed combination of I/Os rising and/or falling edges through the RegInterruptMask and RegSense registers.

If needed, the I/Os which triggered the interrupt can then be identified by reading RegInterruptSource register.

When NINT is low (i.e. interrupt occurred), it can be reset back high (i.e. cleared) by writing 0xFF in RegInterruptSource (this will also clear corresponding bits in RegEventStatus register).

The interrupt can also be cleared automatically when reading RegData register (Cf. RegMisc)

Example: We want to detect rising edge of I/O[1] on SX1508 (NINT will go low).

1. We enable interrupt on I/O[1] in RegInterruptMask
⇒ RegInterruptMask = "XXXXXX0X"

2. We set edge sense for I/O[1] in RegSense
⇒ RegSenseLow = "XXXX01XX"

Please note that independently from the "user defined" process described above the keypad engine, when enabled, also uses NINT to indicate a key press.

Hence we have NINT = "user defined condition occurred" OR "keypad engine condition occurred".

4.8 Clock Management

A main oscillator clock fOSC is needed by the LED driver, keypad engine and debounce features.

Clock management block is illustrated in figure below.

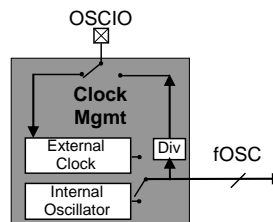

Figure 14 – Clock Management Overview

The block is configured in register RegClock (Cf §5 for more detailed information):

- Selection of internal clock source: none (OFF) or internal oscillator or external clock input from OSCIN.
- Definition of OSCIO pin function (OSCIN or OSCOUT)
- OSCOUT frequency setting (sub-multiple of fOSC)

Please note that if needed the OSCOUT feature can be used as an additional GPO (Cf. RegClock)

4.9 LED Driver

4.9.1 Overview

Every IO has its own independent LED driver to perform intensity control, blinking and fading operation. (Cf §6.2 for typical LED connection)

Please note that while all I/Os can perform intensity control (PWM) only some of them additionally include blinking and breathing features (Cf pin description §1)

The LED drivers of all I/Os share the same clock ClkX configurable in RegMisc[6:4]. Please note that for power consumption reasons ClkX is OFF by default.

ADVANCED COMMUNICATIONS & SENSING

Assuming ClkX is not OFF, LED driver for IO[X] is enabled when RegLEDDriverEnable[X] = 1 in which case it can operate in one of the three modes below:

- Static mode (all I/Os, with or without fade in/out)
- Single shot mode (blinking capable I/Os only, with or without fade in/out)
- Blink mode (blinking capable I/Os only, with or without fade in/out)

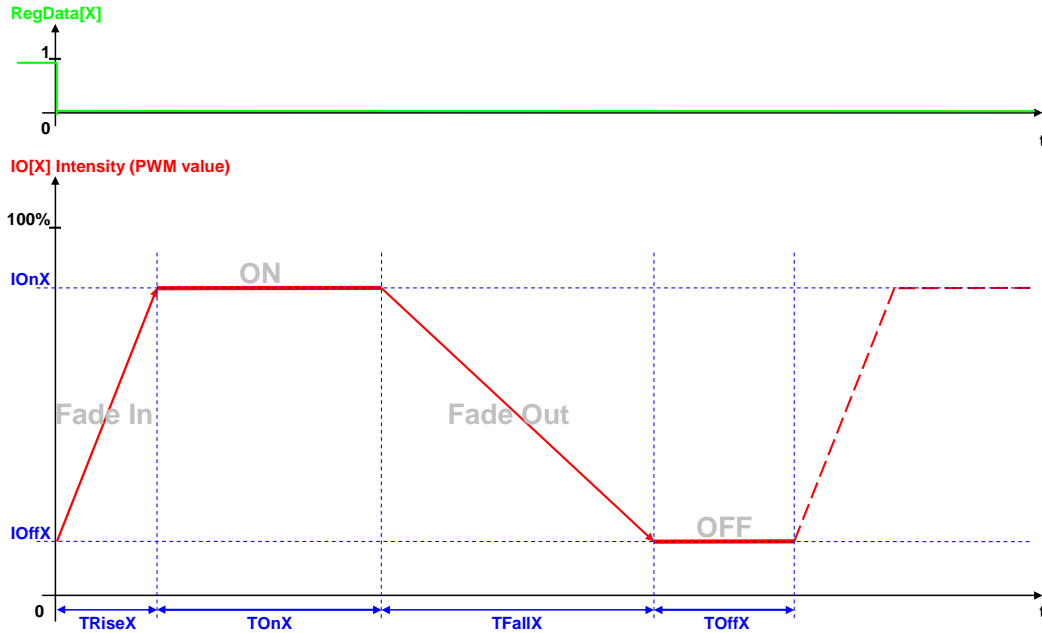

Figure 15 – LED Driver Overview

Each IO[X] has its own set of programmable registers (Cf §5 for more detailed information):

- **RegTOnX** (blinking capable I/Os only): TOnX, ON time of IO[X]
- **RegIOnX** (all I/Os): IOnX, ON intensity of IO[X]
- **RegOffX** (blinking capable I/Os only): TOffX and IOffX, OFF time and intensity of IO[X]
- **RegTRiseX** (breathing capable I/Os only): TRiseX, fade in time of IO[X]
- **RegTFallX** (breathing capable I/Os only): TFallX, fade out time of IO[X]

Please note that the LED driver mode is selectable for each IO bank between linear and logarithmic. (Cf §4.9.5)

All the figures assume normal IO polarity, for inverse polarity RegData control must be inverted (does not invert the polarity of the IO signal itself).

4.9.2 Static Mode

Only mode available for non blinking capable IOs (with Off intensity = 0), else invoked when TOnX = 0. If the I/O doesn't support fading the LED intensity will step directly to the IOnX/IOffX value.

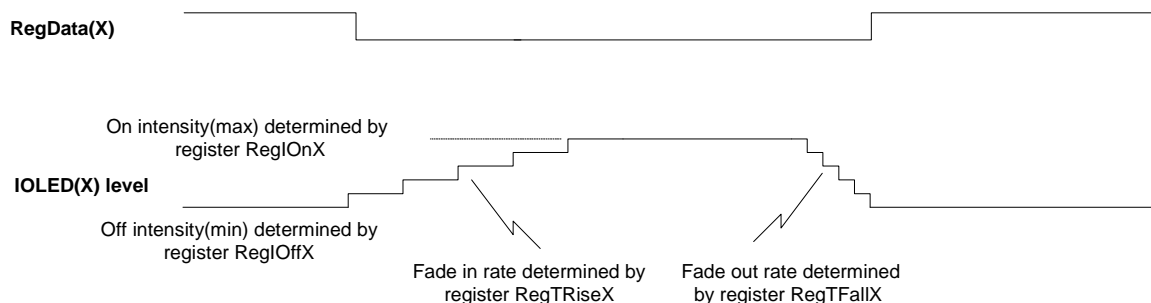

Figure 16 – LED Driver Static Mode

ADVANCED COMMUNICATIONS & SENSING

4.9.3 Single Shot Mode

Invoked when TOnX != 0 and TOffX = 0.

If the I/O doesn't support fading the LED intensity will step directly to the IOnX/IOffX value.

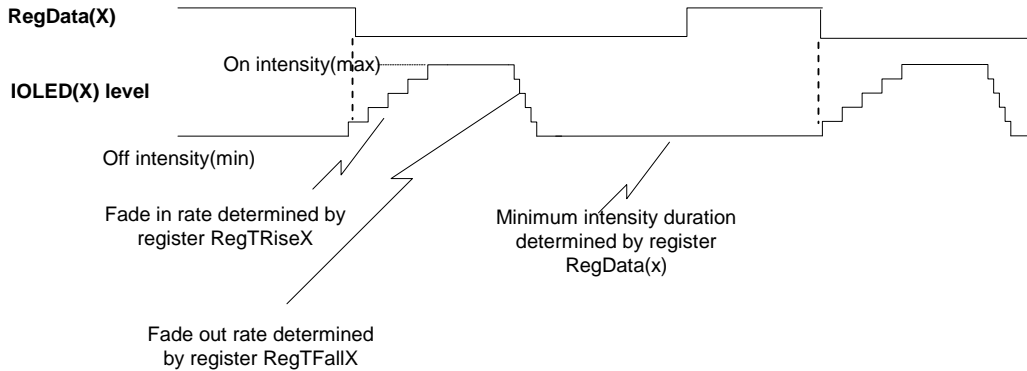

Figure 17 – LED Driver Single Shot Mode

4.9.4 Blink Mode

Invoked when TOnX != 0 and TOffX != 0.

If the I/O doesn't support fading the LED intensity will step directly to the IOnX/IOffX value.

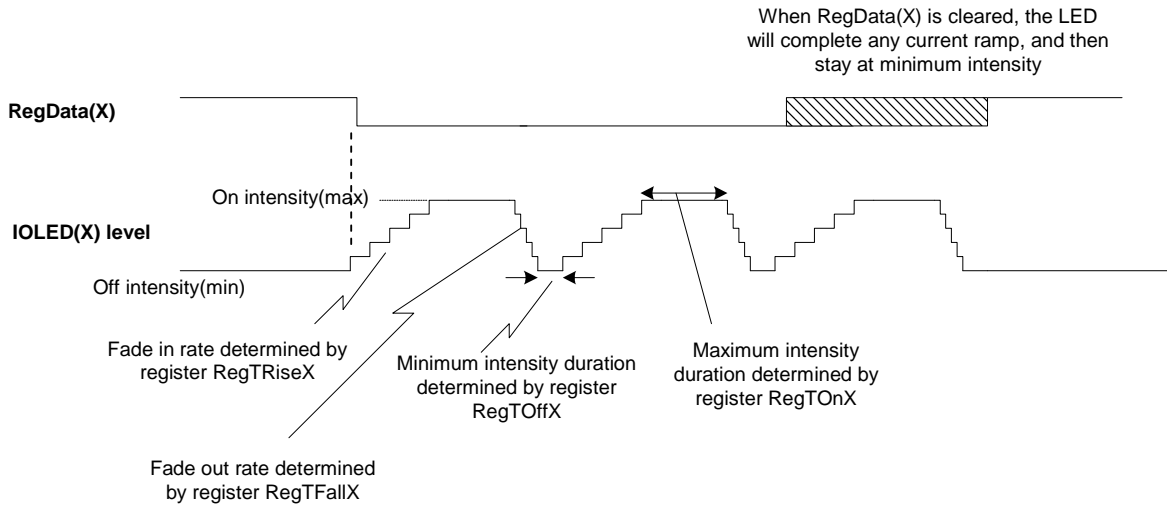

Figure 18 – LED Driver Blink Mode

4.9.5 LED Driver Modes

For each IO bank, the LED driver mode of fading capable IOs can be selected between linear or logarithmic in RegMisc.

Lin.	Log.	Lin.	Log.	Lin.	Log.	Lin.	Log.	Lin.	Log.	Lin.	Log.	Lin.	Log.	Lin.	Log.
0	0	32	4	64	13	96	28	128	53	160	88	192	135	224	198
1	0	33	4	65	13	97	28	129	53	161	88	193	135	225	198
2	0	34	4	66	13	98	30	130	53	162	88	194	135	226	198
3	0	35	4	67	13	99	30	131	53	163	88	195	135	227	198
4	0	36	5	68	14	100	31	132	56	164	93	196	142	228	207
5	0	37	5	69	14	101	31	133	56	165	93	197	142	229	207
6	0	38	5	70	14	102	32	134	56	166	93	198	142	230	207
7	0	39	5	71	14	103	32	135	56	167	93	199	142	231	207

ADVANCED COMMUNICATIONS & SENSING

8	1	40	6	72	16	104	34	136	60	168	98	200	150	232	216
9	1	41	6	73	16	105	34	137	60	169	98	201	150	233	216
10	1	42	6	74	17	106	35	138	60	170	98	202	150	234	216
11	1	43	6	75	17	107	35	139	60	171	98	203	150	235	216
12	1	44	7	76	18	108	36	140	65	172	104	204	157	236	225
13	1	45	7	77	18	109	36	141	65	173	104	205	157	237	225
14	1	46	7	78	19	110	38	142	65	174	104	206	157	238	225
15	1	47	7	79	19	111	38	143	65	175	104	207	157	239	225
16	2	48	8	80	20	112	39	144	69	176	110	208	165	240	235
17	2	49	8	81	20	113	39	145	69	177	110	209	165	241	235
18	2	50	8	82	21	114	41	146	69	178	110	210	165	242	235
19	2	51	8	83	21	115	41	147	69	179	110	211	165	243	235
20	2	52	9	84	22	116	42	148	73	180	116	212	172	244	245
21	2	53	9	85	22	117	42	149	73	181	116	213	172	245	245
22	2	54	9	86	23	118	44	150	73	182	116	214	172	246	245
23	2	55	9	87	23	119	44	151	73	183	116	215	172	247	245
24	3	56	10	88	24	120	46	152	78	184	122	216	181	248	255
25	3	57	10	89	24	121	46	153	78	185	122	217	181	249	255
26	3	58	10	90	25	122	46	154	78	186	122	218	181	250	255
27	3	59	10	91	25	123	46	155	78	187	122	219	181	251	255
28	3	60	11	92	26	124	49	156	83	188	129	220	189	252	255
29	3	61	11	93	26	125	49	157	83	189	129	221	189	253	255
30	3	62	12	94	27	126	49	158	83	190	129	222	189	254	255
31	3	63	12	95	27	127	49	159	83	191	129	223	189	255	255

Table 8 – LED Driver Linear vs Logarithmic Function (I)

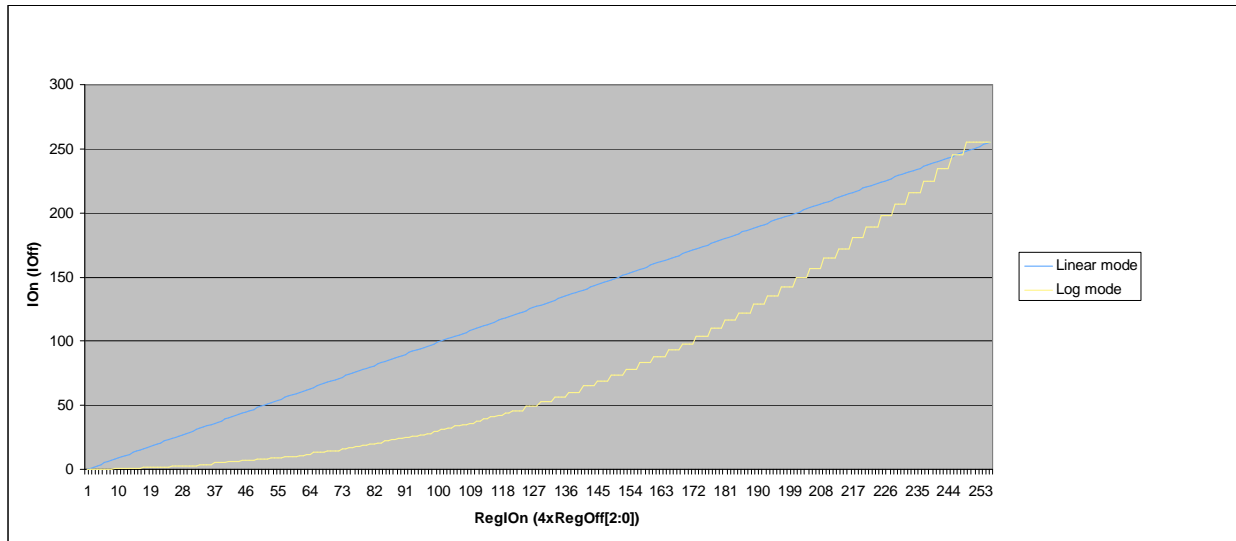

Figure 19 – LED Driver Linear vs Logarithmic Function (II)

4.9.6 Synchronization of LED Drivers across several ICs

When several GPIO expanders are used in the same application it may be useful that their LEDs drivers are synchronous for coherent global operation.

In this case all ICs should share their fOSC through their OSCIO pins and have their NRESET pins connected together.

When RegMisc of each IC is set accordingly, NRESET signal can then be used to reset all devices' internal counters (but not the register settings) and allow synchronous LED operation (blinking, fading) across multiple devices.

ADVANCED COMMUNICATIONS & SENSING4.9.7 Tutorial

Below are the steps required to use the LED driver with the typical LED connection described §6.2:

- Disable input buffer (RegInputDisable)
- Disable pull-up (RegPullUp)
- Enable open drain (RegOpenDrain)
- Set direction to output (RegDir) – by default RegData is set high => LED OFF
- Enable oscillator (RegClock)
- Configure LED driver clock and mode if relevant (RegMisc)
- Enable LED driver operation (RegLEDDriverEnable)
- Configure LED driver parameters (RegTON, RegIOn, RegOff, RegTRise, RegTFall)
- Set RegData bit low => LED driver started

ADVANCED COMMUNICATIONS & SENSING

5 CONFIGURATION REGISTERS

5.1 SX1507 4-channel GPIO with LED Driver

Address	Name	Description	Default
Device and IO Banks			
0x00	RegInputDisable	Input buffer disable register	XXXX 0000
0x01	RegLongSlew	Output buffer long slew register	XXXX 0000
0x02	RegLowDrive	Output buffer low drive register	XXXX 0000
0x03	RegPullUp	Pull-up register	XXXX 0000
0x04	RegPullDown	Pull-down register	XXXX 0000
0x05	RegOpenDrain	Open drain register	XXXX 0000
0x06	RegPolarity	Polarity register	XXXX 0000
0x07	RegDir	Direction register	XXXX 1111
0x08	RegData	Data register	XXXX 1111
0x09	RegInterruptMask	Interrupt mask register	XXXX 1111
0x0A	RegSense	Sense register	0000 0000
0x0B	RegInterruptSource	Interrupt source register	XXXX 0000
0x0C	RegEventStatus	Event status register	XXXX 0000
0x0D	RegClock	Clock management register	0000 0000
0x0E	RegMisc	Miscellaneous device settings register	0000 0000
0x0F	RegLEDDriverEnable	LED driver enable register	XXXX 0000
Debounce			
0x10	RegDebounceConfig	Debounce configuration register	0000 0000
0x11	RegDebounceEnable	Debounce enable register	XXXX 0000
LED Driver (PWM, blinking, breathing)			
0x12	RegTOn0	ON time register for I/O[0]	0000 0000
0x13	RegIon0	ON intensity register for I/O[0]	1111 1111
0x14	RegOff0	OFF time/intensity register for I/O[0]	0000 0000
0x15	RegTOn1	ON time register for I/O[1]	0000 0000
0x16	RegIon1	ON intensity register for I/O[1]	1111 1111
0x17	RegOff1	OFF time/intensity register for I/O[1]	0000 0000
0x18	RegTRise1	Fade in register for I/O[1]	0000 0000
0x19	RegTFall1	Fade out register for I/O[1]	0000 0000
0x1A	RegTOn2	ON time register for I/O[2]	0000 0000
0x1B	RegIon2	ON intensity register for I/O[2]	1111 1111
0x1C	RegOff2	OFF time/intensity register for I/O[2]	0000 0000
0x1D	RegTRise2	Fade in register for I/O[2]	0000 0000
0x1E	RegTFall2	Fade out register for I/O[2]	0000 0000
0x1F	RegTOn3	ON time register for I/O[3]	0000 0000
0x20	RegIon3	ON intensity register for I/O[3]	1111 1111
0x21	RegOff3	OFF time/intensity register for I/O[3]	0000 0000
0x22	RegTRise3	Fade in register for I/O[3]	0000 0000
0x23	RegTFall3	Fade out register for I/O[3]	0000 0000
Software Reset			
0x7D	RegReset	Software reset register	0000 0000
Test (not to be written)			
0x7E	RegTest1	Test register	0000 0000
0x7F	RegTest2	Test register	0000 0000

bits set as output take '1' as default value.

Table 9 – SX1507 Configuration Registers Overview

ADVANCED COMMUNICATIONS & SENSING

Addr	Name	Default	Bits	Description
0x00	RegInputDisable	0xX0	7:4	Unused
			3:0	Disables the input buffer of each IO 0 : Input buffer is enabled (input actually being used) 1 : Input buffer is disabled (input actually not being used or LED connection)
0x01	RegLongSlew	0xX0	7:4	Unused
			3:0	Enables increased slew rate of the output buffer of each [output-configured] IO 0 : Increased slew rate is disabled 1 : Increased slew rate is enabled
0x02	RegLowDrive	0xX0	7:4	Unused
			3:0	Enables reduced drive of the output buffer of each [output-configured] IO 0 : Reduced drive is disabled 1 : Reduced drive is enabled
0x03	RegPullUp	0xX0	7:4	Unused
			3:0	Enables the pull-up for each IO 0 : Pull-up is disabled 1 : Pull-up is enabled
0x04	RegPullDown	0xX0	7:4	Unused
			3:0	Enables the pull-down for each IO 0 : Pull-down is disabled 1 : Pull-down is enabled
0x05	RegOpenDrain	0xX0	7:4	Unused
			3:0	Enables open drain operation for each [output-configured] IO 0 : Regular push-pull operation 1 : Open drain operation
0x06	RegPolarity	0xX0	7:4	Unused
			3:0	Enables polarity inversion for each IO 0 : Normal polarity : RegData[x] = IO[x] 1 : Inverted polarity : RegData[x] = !IO[x] (for both input and output configured IOs)
0x07	RegDir	0xFF	7:4	Unused
			3:0	Configures direction for each IO. 0 : IO is configured as an output 1 : IO is configured as an input
0x08	RegData	0xFF	7:4	Unused
			3:0	Write: Data to be output to the output-configured IOs Read: Data seen at the IOs, independent of the direction configured.
0x09	RegInterruptMask	0xFF	7:4	Unused
			3:0	Configures which [input-configured] IO will trigger an interrupt on NINT pin 0 : An event on this IO will trigger an interrupt 1 : An event on this IO will NOT trigger an interrupt
0x0A	RegSense	0x00	7:6	Edge sensitivity of RegData[3]
			5:4	Edge sensitivity of RegData[2]
			3:2	Edge sensitivity of RegData[1]
			1:0	Edge sensitivity of RegData[0]
0x0B	RegInterruptSource	0xX0	7:4	Unused
			3:0	Interrupt source (from IOs set in RegInterruptMask) 0 : No interrupt has been triggered by this IO 1 : An interrupt has been triggered by this IO (an event as configured in relevant RegSense register occurred). Writing '1' clears the bit in RegInterruptSource and in RegEventStatus When all bits are cleared, NINT signal goes back high.
0x0C	RegEventStatus	0xX0	7:4	Unused
			3:0	Event status of all IOs. 0 : No event has occurred on this IO 1 : An event has occurred on this IO (an edge as configured in relevant RegSense register occurred). Writing '1' clears the bit in RegEventStatus and in RegInterruptSource if relevant. If the edge sensitivity of the IO is changed, the bit(s) will be cleared automatically
0x0D	RegClock	0x00	7	Unused
			6:5	Oscillator frequency (fOSC) source 00 : OFF. LED driver and debounce features are disabled. 01 : External clock input (OSCIN) 10 : Internal 1MHz oscillator 11 : Reserved
			4	OSCIO pin function (Cf. §4.8) 0 : OSCIO is an input (OSCIN) 1 : OSCIO is an output (OSCOU)
			3:0	Frequency of the signal output on OSCOUT pin: 0x0 : 0Hz, permanent "0" logical level (GPO) 0xF : 0Hz, permanent "1" logical level (GPO) Else : fOSCOU = fOSC/(2^(RegClock[3:0]-1))

ADVANCED COMMUNICATIONS & SENSING

0x0E	RegMisc	0x00	7	Unused
			6:4	Frequency of the LED Driver clock ClkX of all IOs: 0 : OFF. LED driver functionality is disabled for all IOs. Else : $ClkX = fOSC / (2^{(RegMisc[6:4]-1)})$
			3	LED Driver mode for Bank A 's fading capable IOs (IO1-3) 0: Linear 1: Logarithmic
			2	NRESET pin function when externally forced low (Cf. §4.4.1 and §4.9.5). 0: Equivalent to POR 1: Reset PWM/Blink/Fade counters (not user programmed values) This bit is can only be reset manually or by POR, not by NRESET.
			1	Auto-increment register address (Cf. §4.5) 0: ON. When several consecutive data are read/written, register address is incremented. 1: OFF. When several consecutive data are read/written, register address is kept fixed.
			0	Autoclear NINT on RegData read (Cf. §4.7) 0: ON. RegInterruptSource is also automatically cleared when RegData is read. 1: OFF. RegInterruptSource must be manually cleared, either directly or via RegEventStatus.
0x0F	RegLEDDriverEnable	0xX0	7:4	Unused
			3:0	Enables LED Driver for each [output-configured] IO 0 : LED Driver is disabled 1 : LED Driver is enabled
0x10	RegDebounceConfig	0x00	7:3	Unused
			2:0	Debounce time (Cf. §4.6.1) 000: 0.5ms x 1MHz/fOSC 001: 1ms x 1MHz/fOSC 010: 2ms x 1MHz/fOSC 011: 4ms x 1MHz/fOSC 100: 8ms x 1MHz/fOSC 101: 16ms x 1MHz/fOSC 110: 32ms x 1MHz/fOSC 111: 64ms x 1MHz/fOSC
0x11	RegDebounceEnable	0xX0	7:4	Unused
			3:0	Enables debouncing for each [input-configured] IO 0 : Debouncing is disabled 1 : Debouncing is enabled
0xXX	RegTOnX	0x00	7:5	Unused
			4:0	ON Time of IO[X]: 0 : Infinite (Static mode, TOn directly controlled by RegData, Cf §4.9.2) 1 - 15 : $TOnX = 64 * RegTOnX * (255/ClkX)$ 16 - 31 : $TOnX = 512 * RegTOnX * (255/ClkX)$
0xXX	RegIOnX	0xFF	7:0	ON Intensity of IO[X] - Linear mode : $IOnX = RegIOnX$ - Logarithmic mode (fading capable IOs only) : $IOnX = f(RegIOnX)$, Cf §4.9.5
0xXX	RegOffX	0x00	7:3	OFF Time of IO[X]: 0 : Infinite (Single shot mode, TOff directly controlled by RegData, Cf §4.9.3) 1 - 15 : $TOffX = 64 * RegOffX[7:3] * (255/ClkX)$ 16 - 31 : $TOffX = 512 * RegOffX[7:3] * (255/ClkX)$
			2:0	OFF Intensity of IO[X] - Linear mode : $IOffX = 4 * RegOff[2:0]$ - Logarithmic mode (fading capable IOs only) : $IOffX = f(4 * RegOffX[2:0])$, Cf §4.9.5
0xXX	RegTRiseX	0x00	7:5	Unused
			4:0	Fade In setting of IO[X] 0 : OFF 1 - 15 : $TRiseX = (RegIOnX - (4 * RegOffX[2:0])) * RegTRiseX * (255/ClkX)$ 16 - 31 : $TRiseX = 16 * (RegIOnX - (4 * RegOffX[2:0])) * RegTRiseX * (255/ClkX)$
0xXX	RegTFallX	0x00	7:5	Unused
			4:0	Fade Out setting of IO[X] 0 : OFF 1 - 15 : $TFallX = (RegIOnX - (4 * RegOffX[2:0])) * RegTFallX * (255/ClkX)$ 16 - 31 : $TFallX = 16 * (RegIOnX - (4 * RegOffX[2:0])) * RegTFallX * (255/ClkX)$
0x7D	RegReset	0x00	7:0	Software reset register Writing consecutively 0x12 and 0x34 will reset the device (same as POR). Always reads 0.

Table 10 – SX1507 Configuration Registers Description

ADVANCED COMMUNICATIONS & SENSING

5.2 SX1508 8-channel GPIO with LED Driver and Keypad Engine

Address	Name	Description	Default
Device and IO Banks			
0x00	RegInputDisable	Input buffer disable register	0000 0000
0x01	RegLongSlew	Output buffer long slew register	0000 0000
0x02	RegLowDrive	Output buffer low drive register	0000 0000
0x03	RegPullUp	Pull-up register	0000 0000
0x04	RegPullDown	Pull-down register	0000 0000
0x05	RegOpenDrain	Open drain register	0000 0000
0x06	RegPolarity	Polarity register	0000 0000
0x07	RegDir	Direction register	1111 1111
0x08	RegData	Data register	1111 1111
0x09	RegInterruptMask	Interrupt mask register	1111 1111
0x0A	RegSenseHigh	Sense register for I/O[7:4]	0000 0000
0x0B	RegSenseLow	Sense register for I/O[3:0]	0000 0000
0x0C	RegInterruptSource	Interrupt source register	0000 0000
0x0D	RegEventStatus	Event status register	0000 0000
0x0E	RegLevelShifter	Level shifter register	0000 0000
0x0F	RegClock	Clock management register	0000 0000
0x10	RegMisc	Miscellaneous device settings register	0000 0000
0x11	RegLEDDriverEnable	LED driver enable register	0000 0000
Debounce and Keypad Engine			
0x12	RegDebounceConfig	Debounce configuration register	0000 0000
0x13	RegDebounceEnable	Debounce enable register	0000 0000
0x14	RegKeyConfig	Key scan configuration register	0000 0000
0x15	RegKeyData	Key value	1111 1111
LED Driver (PWM, blinking, breathing)			
0x16	RegIOn0	ON intensity register for I/O[0]	1111 1111
0x17	RegIOn1	ON intensity register for I/O[1]	1111 1111
0x18	RegTOn2	ON time register for I/O[2]	0000 0000
0x19	RegIOn2	ON intensity register for I/O[2]	1111 1111
0x1A	RegOff2	OFF time/intensity register for I/O[2]	0000 0000
0x1B	RegTOn3	ON time register for I/O[3]	0000 0000
0x1C	RegIOn3	ON intensity register for I/O[3]	1111 1111
0x1D	RegOff3	OFF time/intensity register for I/O[3]	0000 0000
0x1E	RegTRise3	Fade in register for I/O[3]	0000 0000
0x1F	RegTFall3	Fade out register for I/O[3]	0000 0000
0x20	RegIOn4	ON intensity register for I/O[4]	1111 1111
0x21	RegIOn5	ON intensity register for I/O[5]	1111 1111
0x22	RegTOn6	ON time register for I/O[6]	0000 0000
0x23	RegIOn6	ON intensity register for I/O[6]	1111 1111
0x24	RegOff6	OFF time/intensity register for I/O[6]	0000 0000
0x25	RegTOn7	ON time register for I/O[7]	0000 0000
0x26	RegIOn7	ON intensity register for I/O[7]	1111 1111
0x27	RegOff7	OFF time/intensity register for I/O[7]	0000 0000
0x28	RegTRise7	Fade in register for I/O[7]	0000 0000
0x29	RegTFall7	Fade out register for I/O[7]	0000 0000
Miscellaneous			
0x2A	RegHighInput	High input enable register	0000 0000
Software Reset			
0x7D	RegReset	Software reset register	0000 0000
Test (not to be written)			
0x7E	RegTest1	Test register	0000 0000
0x7F	RegTest2	Test register	0000 0000

Bits set as output take "1" as default value.

Table 11 – SX1508 Configuration Registers Overview

ADVANCED COMMUNICATIONS & SENSING

Addr	Name	Default	Bits	Description	
0x00	RegInputDisable	0x00	7:0	Disables the input buffer of each IO 0 : Input buffer is enabled (input actually being used) 1 : Input buffer is disabled (input actually not being used or LED connection)	
0x01	RegLongSlew	0x00	7:0	Enables increased slew rate of the output buffer of each [output-configured] IO 0 : Increased slew rate is disabled 1 : Increased slew rate is enabled	
0x02	RegLowDrive	0x00	7:0	Enables reduced drive of the output buffer of each [output-configured] IO 0 : Reduced drive is disabled 1 : Reduced drive is enabled	
0x03	RegPullUp	0x00	7:0	Enables the pull-up for each IO 0 : Pull-up is disabled 1 : Pull-up is enabled	
0x04	RegPullDown	0x00	7:0	Enables the pull-down for each IO 0 : Pull-down is disabled 1 : Pull-down is enabled	
0x05	RegOpenDrain	0x00	7:0	Enables open drain operation for each [output-configured] IO 0 : Regular push-pull operation 1 : Open drain operation	
0x06	RegPolarity	0x00	7:0	Enables polarity inversion for each IO 0 : Normal polarity : RegData[x] = IO[x] 1 : Inverted polarity : RegData[x] = !IO[x] (for both input and output configured IOs)	
0x07	RegDir	0xFF	7:0	Configures direction for each IO. 0 : IO is configured as an output 1 : IO is configured as an input	
0x08	RegData	0xFF	7:0	Write: Data to be output to the output-configured IOs Read: Data seen at the IOs, independent of the direction configured.	
0x09	RegInterruptMask	0xFF	7:0	Configures which [input-configured] IO will trigger an interrupt on NINT pin 0 : An event on this IO will trigger an interrupt 1 : An event on this IO will NOT trigger an interrupt	
0x0A	RegSenseHigh	0x00	7:6	Edge sensitivity of RegData[7]	00 : None 01 : Rising 10 : Falling 11 : Both
			5:4	Edge sensitivity of RegData[6]	
			3:2	Edge sensitivity of RegData[5]	
			1:0	Edge sensitivity of RegData[4]	
0x0B	RegSenseLow	0x00	7:6	Edge sensitivity of RegData[3]	00 : None 01 : Rising 10 : Falling 11 : Both
			5:4	Edge sensitivity of RegData[2]	
			3:2	Edge sensitivity of RegData[1]	
			1:0	Edge sensitivity of RegData[0]	
0x0C	RegInterruptSource	0x00	7:0	Interrupt source (from IOs set in RegInterruptMask) 0 : No interrupt has been triggered by this IO 1 : An interrupt has been triggered by this IO (an event as configured in relevant RegSense register occurred). Writing '1' clears the bit in RegInterruptSource and in RegEventStatus When all bits are cleared, NINT signal goes back high.	
0x0D	RegEventStatus	0x00	7:0	Event status of all IOs. 0 : No event has occurred on this IO 1 : An event has occurred on this IO (an edge as configured in relevant RegSense register occurred). Writing '1' clears the bit in RegEventStatus and in RegInterruptSource if relevant. If the edge sensitivity of the IO is changed, the bit(s) will be cleared automatically	
0x0E	RegLevelShifter	0x00	7:6	Level shifter mode for IO[3] (Bank A) and IO[7] (Bank B)	00 : OFF 01 : A->B 10 : B->A 11 : Reserved
			5:4	Level shifter mode for IO[2] (Bank A) and IO[6] (Bank B)	
			3:2	Level shifter mode for IO[1] (Bank A) and IO[5] (Bank B)	
			1:0	Level shifter mode for IO[0] (Bank A) and IO[4] (Bank B)	
0x0F	RegClock	0x00	7	Unused	00 : OFF. LED driver, keypad engine and debounce features are disabled. 01 : External clock input (OSCIN) 10 : Internal 2MHz oscillator 11 : Reserved
			6:5	Oscillator frequency (fOSC) source	
			4	OSCIO pin function (Cf. §4.8) 0 : OSCIO is an input (OSCIN) 1 : OSCIO is an output (OSCOU)	
			3:0	Frequency of the signal output on OSCOUT pin: 0x0 : 0Hz, permanent "0" logical level (GPO) 0xF : 0Hz, permanent "1" logical level (GPO) Else : fOSCOU = fOSC/(2^(RegClock[3:0]-1))	
0x10	RegMisc	0x00	7	LED Driver mode for Bank B 's fading capable IOs (IO7) 0 : Linear 1 : Logarithmic	

ADVANCED COMMUNICATIONS & SENSING

			6:4	Frequency of the LED Driver clock ClkX of all IOs: 0 : OFF. LED driver functionality is disabled for all IOs. Else : $ClkX = fOSC / (2^{(RegMisc[6:4]-1)})$
			3	LED Driver mode for Bank A 's fading capable IOs (IO3) 0: Linear 1: Logarithmic
			2	NRESET pin function when externally forced low (Cf. §4.4.1 and §4.9.5). 0: Equivalent to POR 1: Reset PWM/Blink/Fade counters (not user programmed values) This bit is can only be reset manually or by POR, not by NRESET.
			1	Auto-increment register address (Cf. §4.5) 0: ON. When several consecutive data are read/written, register address is incremented. 1: OFF. When several consecutive data are read/written, register address is kept fixed.
			0	Autoclear NINT on RegData read (Cf. §4.7) 0: ON. RegInterruptSource is also automatically cleared when RegData is read. 1: OFF. RegInterruptSource must be manually cleared, either directly or via RegEventStatus.
0x11	RegLEDDriverEnable	0x00	7:0	Enables LED Driver for each [output-configured] IO 0 : LED Driver is disabled 1 : LED Driver is enabled
			7:3	Unused
0x12	RegDebounceConfig	0x00	2:0	Debounce time (Cf. §4.6.1) 000: 0.5ms x 2MHz/fOSC 001: 1ms x 2MHz/fOSC 010: 2ms x 2MHz/fOSC 011: 4ms x 2MHz/fOSC 100: 8ms x 2MHz/fOSC 101: 16ms x 2MHz/fOSC 110: 32ms x 2MHz/fOSC 111: 64ms x 2MHz/fOSC
0x13	RegDebounceEnable	0x00	7:0	Enables debouncing for each [input-configured] IO 0 : Debouncing is disabled 1 : Debouncing is enabled
			7	Unused
			6:5	Number of rows (outputs) + key scan enable 00 : Key scan OFF 01 : 2 rows – IO[0:1] 10 : 3 rows – IO[0:2] 11 : 4 rows – IO[0:3]
			4:3	Number of columns (inputs) 00 : 1 column – IO[4] 01 : 2 columns – IO[4:5] 10 : 3 columns – IO[4:6] 11 : 4 columns – IO[4:7]
			2:0	Scan time per row (must be set above debounce time). 000 : 1ms x 2MHz/fOSC 001 : 2ms x 2MHz/fOSC 010 : 4ms x 2MHz/fOSC 011 : 8ms x 2MHz/fOSC 100 : 16ms x 2MHz/fOSC 101 : 32ms x 2MHz/fOSC 110 : 64ms x 2MHz/fOSC 111 : 128ms x 2MHz/fOSC
0x15	RegKeyData	0xFF	7:0	Key which generated NINT (active low) Ex: RegKeyData=11011110 => key [IO5;IO0] has been pressed and generated NINT When read it is automatically cleared together with NINT and key scan continues.
			7:5	Unused
0xXX	RegTOnX	0x00	4:0	ON Time of IO[X]: 0 : Infinite (Static mode, TOn directly controlled by RegData, Cf §4.9.2) 1 - 15 : $TOnX = 64 * RegTOnX * (255/ClkX)$ 16 - 31 : $TOnX = 512 * RegTOnX * (255/ClkX)$
0xXX	RegIonX	0xFF	7:0	ON Intensity of IO[X] - Linear mode : $IonX = RegIonX$ - Logarithmic mode (fading capable IOs only) : $IonX = f(RegIonX)$, Cf §4.9.5
			7:3	OFF Time of IO[X]: 0 : Infinite (Single shot mode, TOff directly controlled by RegData, Cf §4.9.3) 1 - 15 : $TOffX = 64 * RegOffX[7:3] * (255/ClkX)$ 16 - 31 : $TOffX = 512 * RegOffX[7:3] * (255/ClkX)$
			2:0	OFF Intensity of IO[X] - Linear mode : $IoffX = 4 * RegOff[2:0]$ - Logarithmic mode (fading capable IOs only) : $IoffX = f(4 * RegOffX[2:0])$, Cf §4.9.5
			7:5	Unused
0xXX	RegTRiseX	0x00	4:0	Fade In setting of IO[X] 0 : OFF 1 - 15 : $TRiseX = (RegIonX - (4 * RegOffX[2:0])) * RegTRiseX * (255/ClkX)$ 16 - 31 : $TRiseX = 16 * (RegIonX - (4 * RegOffX[2:0])) * RegTRiseX * (255/ClkX)$

ADVANCED COMMUNICATIONS & SENSING

0xXX	RegTFallX	0x00	7:5	Unused
			4:0	Fade Out setting of IO[X] 0 : OFF 1 - 15 : $TFallX = (RegIO_nX - (4 \times RegOffX[2:0])) \times RegTFallX \times (255/ClkX)$ 16 - 31 : $TFallX = 16 \times (RegIO_nX - (4 \times RegOffX[2:0])) \times RegTFallX \times (255/ClkX)$
0x2A	RegHighInput	0x00	7:0	Enables high input mode for each [input-configured] IO 0 : OFF. VIH max = 3.6V and VCCx min = 1.2V 1 : ON. VIH max = 5.5V and VCCx min = 1.65V
0x7D	RegReset	0x00	7:0	Software reset register Writing consecutively 0x12 and 0x34 will reset the device (same as POR). Always reads 0.

Table 12 – SX1508 Configuration Registers Description

ADVANCED COMMUNICATIONS & SENSING

5.3 SX1509 16-channel GPIO with LED Driver and Keypad Engine

Address	Name	Description	Default
Device and IO Banks			
0x00	RegInputDisableB	Input buffer disable register - I/O[15-8] (Bank B)	0000 0000
0x01	RegInputDisableA	Input buffer disable register - I/O[7-0] (Bank A)	0000 0000
0x02	RegLongSlewB	Output buffer long slew register - I/O[15-8] (Bank B)	0000 0000
0x03	RegLongSlewA	Output buffer long slew register - I/O[7-0] (Bank A)	0000 0000
0x04	RegLowDriveB	Output buffer low drive register - I/O[15-8] (Bank B)	0000 0000
0x05	RegLowDriveA	Output buffer low drive register - I/O[7-0] (Bank A)	0000 0000
0x06	RegPullUpB	Pull-up register - I/O[15-8] (Bank B)	0000 0000
0x07	RegPullUpA	Pull-up register - I/O[7-0] (Bank A)	0000 0000
0x08	RegPullDownB	Pull-down register - I/O[15-8] (Bank B)	0000 0000
0x09	RegPullDownA	Pull-down register - I/O[7-0] (Bank A)	0000 0000
0x0A	RegOpenDrainB	Open drain register - I/O[15-8] (Bank B)	0000 0000
0x0B	RegOpenDrainA	Open drain register - I/O[7-0] (Bank A)	0000 0000
0x0C	RegPolarityB	Polarity register - I/O[15-8] (Bank B)	0000 0000
0x0D	RegPolarityA	Polarity register - I/O[7-0] (Bank A)	0000 0000
0x0E	RegDirB	Direction register - I/O[15-8] (Bank B)	1111 1111
0x0F	RegDirA	Direction register - I/O[7-0] (Bank A)	1111 1111
0x10	RegDataB	Data register - I/O[15-8] (Bank B)	1111 1111
0x11	RegDataA	Data register - I/O[7-0] (Bank A)	1111 1111
0x12	RegInterruptMaskB	Interrupt mask register - I/O[15-8] (Bank B)	1111 1111
0x13	RegInterruptMaskA	Interrupt mask register - I/O[7-0] (Bank A)	1111 1111
0x14	RegSenseHighB	Sense register for I/O[15:12]	0000 0000
0x15	RegSenseLowB	Sense register for I/O[11:8]	0000 0000
0x16	RegSenseHighA	Sense register for I/O[7:4]	0000 0000
0x17	RegSenseLowA	Sense register for I/O[3:0]	0000 0000
0x18	RegInterruptSourceB	Interrupt source register - I/O[15-8] (Bank B)	0000 0000
0x19	RegInterruptSourceA	Interrupt source register - I/O[7-0] (Bank A)	0000 0000
0x1A	RegEventStatusB	Event status register - I/O[15-8] (Bank B)	0000 0000
0x1B	RegEventStatusA	Event status register - I/O[7-0] (Bank A)	0000 0000
0x1C	RegLevelShifter1	Level shifter register	0000 0000
0x1D	RegLevelShifter2	Level shifter register	0000 0000
0x1E	RegClock	Clock management register	0000 0000
0x1F	RegMisc	Miscellaneous device settings register	0000 0000
0x20	RegLEDDriverEnableB	LED driver enable register - I/O[15-8] (Bank B)	0000 0000
0x21	RegLEDDriverEnableA	LED driver enable register - I/O[7-0] (Bank A)	0000 0000
Debounce and Keypad Engine			
0x22	RegDebounceConfig	Debounce configuration register	0000 0000
0x23	RegDebounceEnableB	Debounce enable register - I/O[15-8] (Bank B)	0000 0000
0x24	RegDebounceEnableA	Debounce enable register - I/O[7-0] (Bank A)	0000 0000
0x25	RegKeyConfig1	Key scan configuration register	0000 0000
0x26	RegKeyConfig2	Key scan configuration register	0000 0000
0x27	RegKeyData1	Key value (column)	1111 1111
0x28	RegKeyData2	Key value (row)	1111 1111
LED Driver (PWM, blinking, breathing)			
0x29	RegTOn0	ON time register for I/O[0]	0000 0000
0x2A	RegIOn0	ON intensity register for I/O[0]	1111 1111
0x2B	RegOff0	OFF time/intensity register for I/O[0]	0000 0000
0x2C	RegTOn1	ON time register for I/O[1]	0000 0000
0x2D	RegIOn1	ON intensity register for I/O[1]	1111 1111
0x2E	RegOff1	OFF time/intensity register for I/O[1]	0000 0000
0x2F	RegTOn2	ON time register for I/O[2]	0000 0000
0x30	RegIOn2	ON intensity register for I/O[2]	1111 1111
0x31	RegOff2	OFF time/intensity register for I/O[2]	0000 0000
0x32	RegTOn3	ON time register for I/O[3]	0000 0000
0x33	RegIOn3	ON intensity register for I/O[3]	1111 1111
0x34	RegOff3	OFF time/intensity register for I/O[3]	0000 0000
0x35	RegTOn4	ON time register for I/O[4]	0000 0000
0x36	RegIOn4	ON intensity register for I/O[4]	1111 1111
0x37	RegOff4	OFF time/intensity register for I/O[4]	0000 0000
0x38	RegTRise4	Fade in register for I/O[4]	0000 0000

ADVANCED COMMUNICATIONS & SENSING

Address	Name	Description	Default
0x39	RegTFall4	Fade out register for I/O[4]	0000 0000
0x3A	RegTOn5	ON time register for I/O[5]	0000 0000
0x3B	RegIOn5	ON intensity register for I/O[5]	1111 1111
0x3C	RegOff5	OFF time/intensity register for I/O[5]	0000 0000
0x3D	RegTRise5	Fade in register for I/O[5]	0000 0000
0x3E	RegTFall5	Fade out register for I/O[5]	0000 0000
0x3F	RegTOn6	ON time register for I/O[6]	0000 0000
0x40	RegIOn6	ON intensity register for I/O[6]	1111 1111
0x41	RegOff6	OFF time/intensity register for I/O[6]	0000 0000
0x42	RegTRise6	Fade in register for I/O[6]	0000 0000
0x43	RegTFall6	Fade out register for I/O[6]	0000 0000
0x44	RegTOn7	ON time register for I/O[7]	0000 0000
0x45	RegIOn7	ON intensity register for I/O[7]	1111 1111
0x46	RegOff7	OFF time/intensity register for I/O[7]	0000 0000
0x47	RegTRise7	Fade in register for I/O[7]	0000 0000
0x48	RegTFall7	Fade out register for I/O[7]	0000 0000
0x49	RegTOn8	ON time register for I/O[8]	0000 0000
0x4A	RegIOn8	ON intensity register for I/O[8]	1111 1111
0x4B	RegOff8	OFF time/intensity register for I/O[8]	0000 0000
0x4C	RegTOn9	ON time register for I/O[9]	0000 0000
0x4D	RegIOn9	ON intensity register for I/O[9]	1111 1111
0x4E	RegOff9	OFF time/intensity register for I/O[9]	0000 0000
0x4F	RegTOn10	ON time register for I/O[10]	0000 0000
0x50	RegIOn10	ON intensity register for I/O[10]	1111 1111
0x51	RegOff10	OFF time/intensity register for I/O[10]	0000 0000
0x52	RegTOn11	ON time register for I/O[11]	0000 0000
0x53	RegIOn11	ON intensity register for I/O[11]	1111 1111
0x54	RegOff11	OFF time/intensity register for I/O[11]	0000 0000
0x55	RegTOn12	ON time register for I/O[12]	0000 0000
0x56	RegIOn12	ON intensity register for I/O[12]	1111 1111
0x57	RegOff12	OFF time/intensity register for I/O[12]	0000 0000
0x58	RegTRise12	Fade in register for I/O[12]	0000 0000
0x59	RegTFall12	Fade out register for I/O[12]	0000 0000
0x5A	RegTOn13	ON time register for I/O[13]	0000 0000
0x5B	RegIOn13	ON intensity register for I/O[13]	1111 1111
0x5C	RegOff13	OFF time/intensity register for I/O[13]	0000 0000
0x5D	RegTRise13	Fade in register for I/O[13]	0000 0000
0x5E	RegTFall13	Fade out register for I/O[13]	0000 0000
0x5F	RegTOn14	ON time register for I/O[14]	0000 0000
0x60	RegIOn14	ON intensity register for I/O[14]	1111 1111
0x61	RegOff14	OFF time/intensity register for I/O[14]	0000 0000
0x62	RegTRise14	Fade in register for I/O[14]	0000 0000
0x63	RegTFall14	Fade out register for I/O[14]	0000 0000
0x64	RegTOn15	ON time register for I/O[15]	0000 0000
0x65	RegIOn15	ON intensity register for I/O[15]	1111 1111
0x66	RegOff15	OFF time/intensity register for I/O[15]	0000 0000
0x67	RegTRise15	Fade in register for I/O[15]	0000 0000
0x68	RegTFall15	Fade out register for I/O[15]	0000 0000
Miscellaneous			
0x69	RegHighInputB	High input enable register - I/O[15-8] (Bank B)	0000 0000
0x6A	RegHighInputA	High input enable register - I/O[7-0] (Bank A)	0000 0000
Software Reset			
0x7D	RegReset	Software reset register	0000 0000
Test (not to be written)			
0x7E	RegTest1	Test register	0000 0000
0x7F	RegTest2	Test register	0000 0000

Bits set as output take "1" as default value.

Table 13 – SX1509 Configuration Registers Overview

ADVANCED COMMUNICATIONS & SENSING

Addr	Name	Default	Bits	Description	
0x00	RegInputDisableB	0x00	7:0	Disables the input buffer of each IO 0 : Input buffer is enabled (input actually being used) 1 : Input buffer is disabled (input actually not being used or LED connection)	
0x01	RegInputDisableA	0x00	7:0	Disables the input buffer of each IO 0 : Input buffer is enabled (input actually being used) 1 : Input buffer is disabled (input actually not being used, LED connection)	
0x02	RegLongSlewB	0x00	7:0	Enables increased slew rate of the output buffer of each [output-configured] IO 0 : Increased slew rate is disabled 1 : Increased slew rate is enabled	
0x03	RegLongSlewA	0x00	7:0	Enables increased slew rate of the output buffer of each [output-configured] IO 0 : Increased slew rate is disabled 1 : Increased slew rate is enabled	
0x04	RegLowDriveB	0x00	7:0	Enables reduced drive of the output buffer of each [output-configured] IO 0 : Reduced drive is disabled 1 : Reduced drive is enabled	
0x05	RegLowDriveA	0x00	7:0	Enables reduced drive of the output buffer of each [output-configured] IO 0 : Reduced drive is disabled 1 : Reduced drive is enabled	
0x06	RegPullUpB	0x00	7:0	Enables the pull-up for each IO 0 : Pull-up is disabled 1 : Pull-up is enabled	
0x07	RegPullUpA	0x00	7:0	Enables the pull-up for each IO 0 : Pull-up is disabled 1 : Pull-up is enabled	
0x08	RegPullDownB	0x00	7:0	Enables the pull-down for each IO 0 : Pull-down is disabled 1 : Pull-down is enabled	
0x09	RegPullDownA	0x00	7:0	Enables the pull-down for each IO 0 : Pull-down is disabled 1 : Pull-down is enabled	
0x0A	RegOpenDrainB	0x00	7:0	Enables open drain operation for each [output-configured] IO 0 : Regular push-pull operation 1 : Open drain operation	
0x0B	RegOpenDrainA	0x00	7:0	Enables open drain operation for each [output-configured] IO 0 : Regular push-pull operation 1 : Open drain operation	
0x0C	RegPolarityB	0x00	7:0	Enables polarity inversion for each IO 0 : Normal polarity : RegData[x] = IO[x] 1 : Inverted polarity : RegData[x] = !IO[x] (for both input and output configured IOs)	
0x0D	RegPolarityA	0x00	7:0	Enables polarity inversion for each IO 0 : Normal polarity : RegData[x] = IO[x] 1 : Inverted polarity : RegData[x] = !IO[x] (for both input and output configured IOs)	
0x0E	RegDirB	0xFF	7:0	Configures direction for each IO. 0 : IO is configured as an output 1 : IO is configured as an input	
0x0F	RegDirA	0xFF	7:0	Configures direction for each IO. 0 : IO is configured as an output 1 : IO is configured as an input	
0x10	RegDataB	0xFF	7:0	Write: Data to be output to the output-configured IOs Read: Data seen at the IOs, independent of the direction configured.	
0x11	RegDataA	0xFF	7:0	Write: Data to be output to the output-configured IOs Read: Data seen at the IOs, independent of the direction configured.	
0x12	RegInterruptMaskB	0xFF	7:0	Configures which [input-configured] IO will trigger an interrupt on NINT pin 0 : An event on this IO will trigger an interrupt 1 : An event on this IO will NOT trigger an interrupt	
0x13	RegInterruptMaskA	0xFF	7:0	Configures which [input-configured] IO will trigger an interrupt on NINT pin 0 : An event on this IO will trigger an interrupt 1 : An event on this IO will NOT trigger an interrupt	
0x14	RegSenseHighB	0x00	7:6	Edge sensitivity of RegData[15]	00 : None 01 : Rising 10 : Falling 11 : Both
			5:4	Edge sensitivity of RegData[14]	
			3:2	Edge sensitivity of RegData[13]	
			1:0	Edge sensitivity of RegData[12]	
0x15	RegSenseLowB	0x00	7:6	Edge sensitivity of RegData[11]	00 : None 01 : Rising 10 : Falling 11 : Both
			5:4	Edge sensitivity of RegData[10]	
			3:2	Edge sensitivity of RegData[9]	
			1:0	Edge sensitivity of RegData[8]	
0x16	RegSenseHighA	0x00	7:6	Edge sensitivity of RegData[7]	00 : None 01 : Rising 10 : Falling 11 : Both
			5:4	Edge sensitivity of RegData[6]	
			3:2	Edge sensitivity of RegData[5]	
			1:0	Edge sensitivity of RegData[4]	
0x17	RegSenseLowA	0x00	7:6	Edge sensitivity of RegData[3]	00 : None

ADVANCED COMMUNICATIONS & SENSING

			5:4	Edge sensitivity of RegData[2]	
			3:2	Edge sensitivity of RegData[1]	
			1:0	Edge sensitivity of RegData[0]	
0x18	RegInterruptSourceB	0x00	7:0	Interrupt source (from IOs set in RegInterruptMask) 0 : No interrupt has been triggered by this IO 1 : An interrupt has been triggered by this IO (an event as configured in relevant RegSense register occurred). Writing '1' clears the bit in RegInterruptSource and in RegEventStatus When all bits are cleared, NINT signal goes back high.	
0x19	RegInterruptSourceA	0x00	7:0	Interrupt source (from IOs set in RegInterruptMask) 0 : No interrupt has been triggered by this IO 1 : An interrupt has been triggered by this IO (an event as configured in relevant RegSense register occurred). Writing '1' clears the bit in RegInterruptSource and in RegEventStatus When all bits are cleared, NINT signal goes back high.	
0x1A	RegEventStatusB	0x00	7:0	Event status of all IOs. 0 : No event has occurred on this IO 1 : An event has occurred on this IO (an edge as configured in relevant RegSense register occurred). Writing '1' clears the bit in RegEventStatus and in RegInterruptSource if relevant. If the edge sensitivity of the IO is changed, the bit(s) will be cleared automatically	
0x1B	RegEventStatusA	0x00	7:0	Event status of all IOs. 0 : No event has occurred on this IO 1 : An event has occurred on this IO (an edge as configured in relevant RegSense register occurred). Writing '1' clears the bit in RegEventStatus and in RegInterruptSource if relevant. If the edge sensitivity of the IO is changed, the bit(s) will be cleared automatically	
0x1C	RegLevelShifter1	0x00	7:6	Level shifter mode for IO[7] (Bank A) and IO[15] (Bank B)	00 : OFF
			5:4	Level shifter mode for IO[6] (Bank A) and IO[14] (Bank B)	01 : A->B
			3:2	Level shifter mode for IO[5] (Bank A) and IO[13] (Bank B)	10 : B->A
			1:0	Level shifter mode for IO[4] (Bank A) and IO[12] (Bank B)	11 : Reserved
0x1D	RegLevelShifter2	0x00	7:6	Level shifter mode for IO[3] (Bank A) and IO[11] (Bank B)	00 : OFF
			5:4	Level shifter mode for IO[2] (Bank A) and IO[10] (Bank B)	01 : A->B
			3:2	Level shifter mode for IO[1] (Bank A) and IO[9] (Bank B)	10 : B->A
			1:0	Level shifter mode for IO[0] (Bank A) and IO[8] (Bank B)	11 : Reserved
0x1E	RegClock	0x00	7	Unused	
			6:5	Oscillator frequency (fOSC) source 00 : OFF. LED driver, keypad engine and debounce features are disabled. 01 : External clock input (OSCIN) 10 : Internal 2MHz oscillator 11 : Reserved	
			4	OSCIO pin function (Cf. §4.8) 0 : OSCIO is an input (OSCIN) 1 : OSCIO is an output (OSCOU)	
			3:0	Frequency of the signal output on OSCOUT pin: 0x0 : 0Hz, permanent "0" logical level (GPO) 0xF : 0Hz, permanent "1" logical level (GPO) Else : fOSCOU = fOSC/(2^(RegClock[3:0]-1))	
0x1F	RegMisc	0x00	7	LED Driver mode for Bank B 's fading capable IOs (IO15-12) 0 : Linear 1 : Logarithmic	
			6:4	Frequency of the LED Driver clock ClkX of all IOs: 0 : OFF. LED driver functionality is disabled for all IOs. Else : ClkX = fOSC/(2^(RegMisc[6:4]-1))	
			3	LED Driver mode for Bank A 's fading capable IOs (IO7-4) 0 : Linear 1 : Logarithmic	
			2	NRESET pin function when externally forced low (Cf. §4.4.1 and §4.9.5) 0 : Equivalent to POR 1 : Reset PWM/Blink/Fade counters (not user programmed values) This bit is can only be reset manually or by POR, not by NRESET.	
			1	Auto-increment register address (Cf. §4.5) 0 : ON. When several consecutive data are read/written, register address is incremented. 1 : OFF. When several consecutive data are read/written, register address is kept fixed.	
			0	Autoclear NINT on RegData read (Cf. §4.7) 0 : ON. RegInterruptSourceA/B is also automatically cleared when RegDataA/B is read. 1 : OFF. RegInterruptSourceA/B must be manually cleared, either directly or via RegEventStatusA/B.	
0x20	RegLEDDriverEnableB	0x00	7:0	Enables LED Driver for each [output-configured] IO 0 : LED Driver is disabled 1 : LED Driver is enabled	

ADVANCED COMMUNICATIONS & SENSING

0x21	RegLEDDriverEnableA	0x00	7:0	Enables LED Driver for each [output-configured] IO 0 : LED Driver is disabled 1 : LED Driver is enabled
0x22	RegDebounceConfig	0x00	7:3	Unused
			2:0	Debounce time (Cf. §4.6.1) 000: 0.5ms x 2MHz/fOSC 001: 1ms x 2MHz/fOSC 010: 2ms x 2MHz/fOSC 011: 4ms x 2MHz/fOSC 100: 8ms x 2MHz/fOSC 101: 16ms x 2MHz/fOSC 110: 32ms x 2MHz/fOSC 111: 64ms x 2MHz/fOSC
0x23	RegDebounceEnableB	0x00	7:0	Enables debouncing for each [input-configured] IO 0 : Debouncing is disabled 1 : Debouncing is enabled
0x24	RegDebounceEnableA	0x00	7:0	Enables debouncing for each [input-configured] IO 0 : Debouncing is disabled 1 : Debouncing is enabled
0x25	RegKeyConfig1	0x00	7	Reserved
			6:4	Auto Sleep time (no key press within this time will set keypad engine to sleep) 000 : OFF 001 : 128ms x 2MHz/fOSC 010 : 256ms x 2MHz/fOSC 011 : 512ms x 2MHz/fOSC 100 : 1sec x 2MHz/fOSC 101 : 2sec x 2MHz/fOSC 110 : 4sec x 2MHz/fOSC 111 : 8sec x 2MHz/fOSC
			2:0	Scan time per row (must be set above debounce time). 000 : 1ms x 2MHz/fOSC 001 : 2ms x 2MHz/fOSC 010 : 4ms x 2MHz/fOSC 011 : 8ms x 2MHz/fOSC 100 : 16ms x 2MHz/fOSC 101 : 32ms x 2MHz/fOSC 110 : 64ms x 2MHz/fOSC 111 : 128ms x 2MHz/fOSC
0x26	RegKeyConfig2	0x00	7:6	Unused
			5:3	Number of rows (outputs) + key scan enable 000 : Key scan OFF 001 : 2 rows – IO[0:1] 010 : 3 rows – IO[0:2] 011 : 4 rows – IO[0:3] 100 : 5 rows – IO[0:4] 101 : 6 rows – IO[0:5] 110 : 7 rows – IO[0:6] 111 : 8 rows – IO[0:7]
			2:0	Number of columns (inputs) 000 : 1 column – IO[8] 001 : 2 columns – IO[8:9] 010 : 3 columns – IO[8:10] 011 : 4 columns – IO[8:11] 100 : 5 columns – IO[8:12] 101 : 6 columns – IO[8:13] 110 : 7 columns – IO[8:14] 111 : 8 columns – IO[8:15]
0x27	RegKeyData1	0xFF	7:0	Column which generated NINT (active low) Ex: RegKeyData1=11011111 => IO13 has generated NINT The register is automatically cleared when RegKeyData2 is read.
0x28	RegKeyData2	0xFF	7:0	Row which generated NINT (active low) Ex: RegKeyData2=11111110 => IO0 has generated NINT When the register is read both RegKeyData1 & RegKeyData2 are automatically cleared together with NINT and key scan continues.
0xXX	RegTOnX	0x00	7:5	Unused
			4:0	ON Time of IO[X]: 0 : Infinite (Static mode, TOn directly controlled by RegData, Cf §4.9.2) 1 - 15 : TOnX = 64 * RegTOnX * (255/ClkX) 16 - 31 : TOnX = 512 * RegTOnX * (255/ClkX)
0xXX	RegIonX	0xFF	7:0	ON Intensity of IO[X] - Linear mode : IO _N X = RegIonX - Logarithmic mode (fading capable IOs only) : IO _N X = f(RegIonX) , Cf §4.9.5

ADVANCED COMMUNICATIONS & SENSING

0xXX	RegOffX	0x00	7:3	OFF Time of IO[X]: 0 : Infinite (Single shot mode, TOff directly controlled by RegData, Cf §4.9.3) 1 - 15 : TOffX = $64 * \text{RegOffX}[7:3] * (255/\text{ClkX})$ 16 - 31 : TOffX = $512 * \text{RegOffX}[7:3] * (255/\text{ClkX})$
			2:0	OFF Intensity of IO[X] - Linear mode : IOffX = $4 * \text{RegOff}[2:0]$ - Logarithmic mode (fading capable IOs only) : IOffX = $f(4 * \text{RegOffX}[2:0])$, Cf §4.9.5
0xXX	RegTRiseX	0x00	7:5	Unused
			4:0	Fade In setting of IO[X] 0 : OFF 1 - 15 : TRiseX = $(\text{RegOnX} - (4 * \text{RegOffX}[2:0])) * \text{RegTRiseX} * (255/\text{ClkX})$ 16 - 31 : TRiseX = $16 * (\text{RegOnX} - (4 * \text{RegOffX}[2:0])) * \text{RegTRiseX} * (255/\text{ClkX})$
0xXX	RegTFallX	0x00	7:5	Unused
			4:0	Fade Out setting of IO[X] 0 : OFF 1 - 15 : TFallX = $(\text{RegOnX} - (4 * \text{RegOffX}[2:0])) * \text{RegTFallX} * (255/\text{ClkX})$ 16 - 31 : TFallX = $16 * (\text{RegOnX} - (4 * \text{RegOffX}[2:0])) * \text{RegTFallX} * (255/\text{ClkX})$
0x69	RegHighInputB	0x00	7:0	Enables high input mode for each [input-configured] IO 0 : OFF. VIH max = 3.6V and VCCx min = 1.2V 1 : ON. VIH max = 5.5V and VCCx min = 1.65V
0x6A	RegHighInputA	0x00	7:0	Enables high input mode for each [input-configured] IO 0 : OFF. VIH max = 3.6V and VCCx min = 1.2V 1 : ON. VIH max = 5.5V and VCCx min = 1.65V
0x7D	RegReset	0x00	7:0	Software reset register Writing consecutively 0x12 and 0x34 will reset the device (same as POR). Always reads 0.

Table 14 – SX1509 Configuration Registers Description

ADVANCED COMMUNICATIONS & SENSING

6 APPLICATION INFORMATION

6.1 Typical Application Circuit

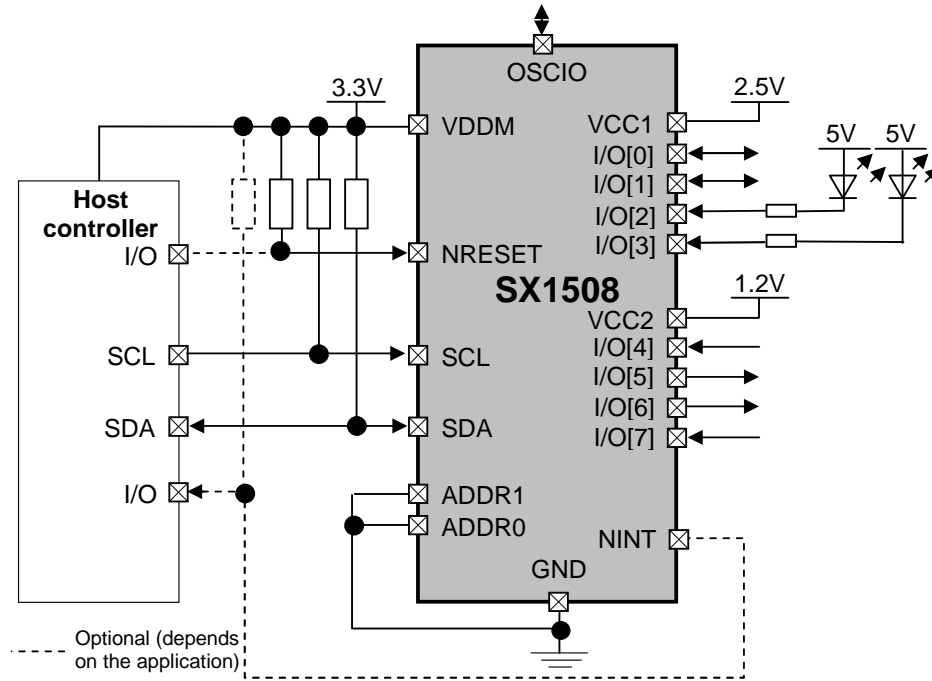

Figure 20 - Typical Application Schematic

6.2 Typical LED Connection

Typical LED Connection is described below. The LED is usually connected to a high voltage (VBAT) to take advantage of the high sink current of the I/O and to accommodate high LED threshold voltages (VLED).

Please note that in this configuration the IO must be programmed as open drain output (RegOpenDrain) with no pull-up (RegPullUp) and input buffer must be disabled (RegInputBufferDisable).

VCCx can take any value without compromising LED operation.

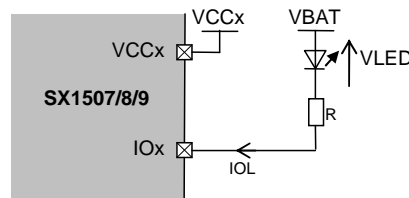

LED colour/technology dependent

Figure 21 - Typical LED Operation

Serial R must be calculated for IOL not to exceed its max spec (Cf. Table 5) else VOL will increase.

ADVANCED COMMUNICATIONS & SENSING**7 PACKAGING INFORMATION****7.1 QFN-UT 14-pin Outline Drawing**

QFN 14-pin, 2 x 2 mm, 0.4 mm pitch

Figure 22 – QFN-UT 14-pin Outline Drawing

7.2 QFN-UT 14-pin Land Pattern

Figure 23 – QFN-UT 14-pin Land Pattern

ADVANCED COMMUNICATIONS & SENSING

7.3 QFN-UT 20-pin Outline Drawing

QFN-UT 20-pin, 3 x 3 mm, 0.4 mm pitch

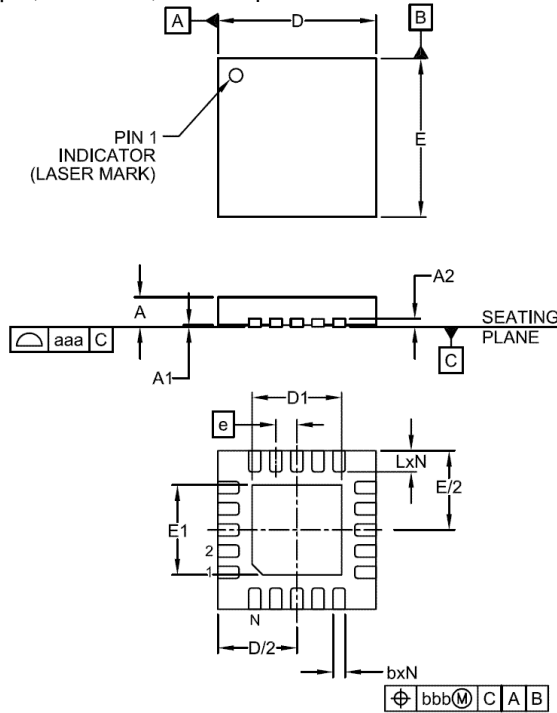

DIM	DIMENSIONS					
	INCHES			MILLIMETERS		
	MIN	NOM	MAX	MIN	NOM	MAX
A	.020	-	.024	0.50	-	0.60
A1	.000	-	.002	0.00	-	0.05
A2	(0.006)			(0.152)		
b	.006	.008	.010	0.15	0.20	0.25
D	.114	.118	.122	2.90	3.00	3.10
D1	.061	.067	.071	1.55	1.70	1.80
E	.114	.118	.122	2.90	3.00	3.10
E1	.061	.067	.071	1.55	1.70	1.80
e	.016 BSC			0.40 BSC		
L	.012	.016	.020	0.30	0.40	0.50
N	20			20		
aaa	.003			0.08		
bbb	.004			0.10		

NOTES:

1. CONTROLLING DIMENSIONS ARE IN MILLIMETERS (ANGLES IN DEGREES).
2. COPLANARITY APPLIES TO THE EXPOSED PAD AS WELL AS THE TERMINALS.
3. DAP IS 1.90 x 1.90mm.

Figure 24 - QFN-UT 20-pin Outline Drawing

7.4 QFN-UT 20-pin Land Pattern

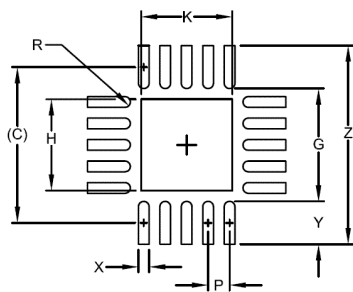

DIM	DIMENSIONS	
	INCHES	MILLIMETERS
C	(.114)	(2.90)
G	.083	2.10
H	.067	1.70
K	.067	1.70
P	.016	0.40
R	.004	0.10
X	.008	0.20
Y	.031	0.80
Z	.146	3.70

NOTES:

1. CONTROLLING DIMENSIONS ARE IN MILLIMETERS (ANGLES IN DEGREES).
2. THIS LAND PATTERN IS FOR REFERENCE PURPOSES ONLY. CONSULT YOUR MANUFACTURING GROUP TO ENSURE YOUR COMPANY'S MANUFACTURING GUIDELINES ARE MET.
3. THERMAL VIAS IN THE LAND PATTERN OF THE EXPOSED PAD SHALL BE CONNECTED TO A SYSTEM GROUND PLANE. FAILURE TO DO SO MAY COMPROMISE THE THERMAL AND/OR FUNCTIONAL PERFORMANCE OF THE DEVICE.

Figure 25 - QFN-UT 20-pin Land Pattern

ADVANCED COMMUNICATIONS & SENSING

7.5 QFN-UT 28-pin Outline Drawing

QFN-UT 28-pin, 4 x 4 mm, 0.4 mm pitch

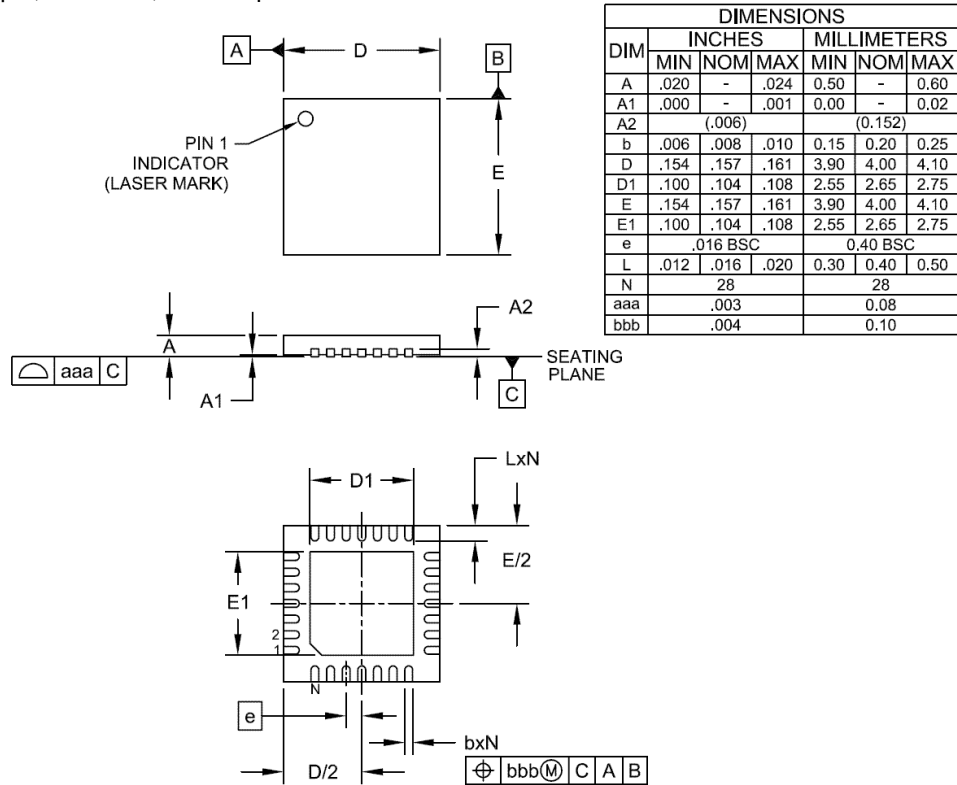

NOTES:

1. CONTROLLING DIMENSIONS ARE IN MILLIMETERS (ANGLES IN DEGREES).
2. COPLANARITY APPLIES TO THE EXPOSED PAD AS WELL AS THE TERMINALS.

Figure 26 - QFN-UT 28-pin Outline Drawing

7.6 QFN-UT 28-pin Land Pattern

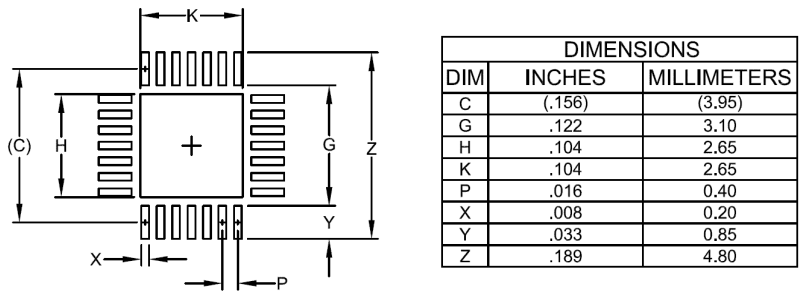

NOTES:

1. CONTROLLING DIMENSIONS ARE IN MILLIMETERS (ANGLES IN DEGREES).
2. THIS LAND PATTERN IS FOR REFERENCE PURPOSES ONLY. CONSULT YOUR MANUFACTURING GROUP TO ENSURE YOUR COMPANY'S MANUFACTURING GUIDELINES ARE MET.
3. THERMAL VIAS IN THE LAND PATTERN OF THE EXPOSED PAD SHALL BE CONNECTED TO A SYSTEM GROUND PLANE. FAILURE TO DO SO MAY COMPROMISE THE THERMAL AND/OR FUNCTIONAL PERFORMANCE OF THE DEVICE.
4. SQUARE PACKAGE-DIMENSIONS APPLY IN BOTH X AND Y DIRECTIONS.

Figure 27 - QFN-UT 28-pin Land Pattern

ADVANCED COMMUNICATIONS & SENSING

8 SOLDERING PROFILE

The soldering reflow profile for the SX1507, SX1508 and SX1509 is described in the standard IPC/JEDEC J-STD-020C. For detailed information please go to <http://www.jedec.org/download/search/jstd020c.pdf>

Profile Feature	Sn-Pb Eutectic Assembly	Pb-Free Assembly
Average Ramp-Up Rate (Ts _{max} to Tp)	3 °C/second max.	3° C/second max.
Preheat		
- Temperature Min (Ts _{min})	100 °C	150 °C
- Temperature Max (Ts _{max})	150 °C	200 °C
- Time (ts _{min} to ts _{max})	60-120 seconds	60-180 seconds
Time maintained above:		
- Temperature (T _L)	183 °C	217 °C
- Time (t _L)	60-150 seconds	60-150 seconds
Peak/Classification Temperature (Tp)	See Table 4.1	See Table 4.2
Time within 5 °C of actual Peak Temperature (tp)	10-30 seconds	20-40 seconds
Ramp-Down Rate	6 °C/second max.	6 °C/second max.
Time 25 °C to Peak Temperature	6 minutes max.	8 minutes max.

Note 1: All temperatures refer to topside of the package, measured on the package body surface.

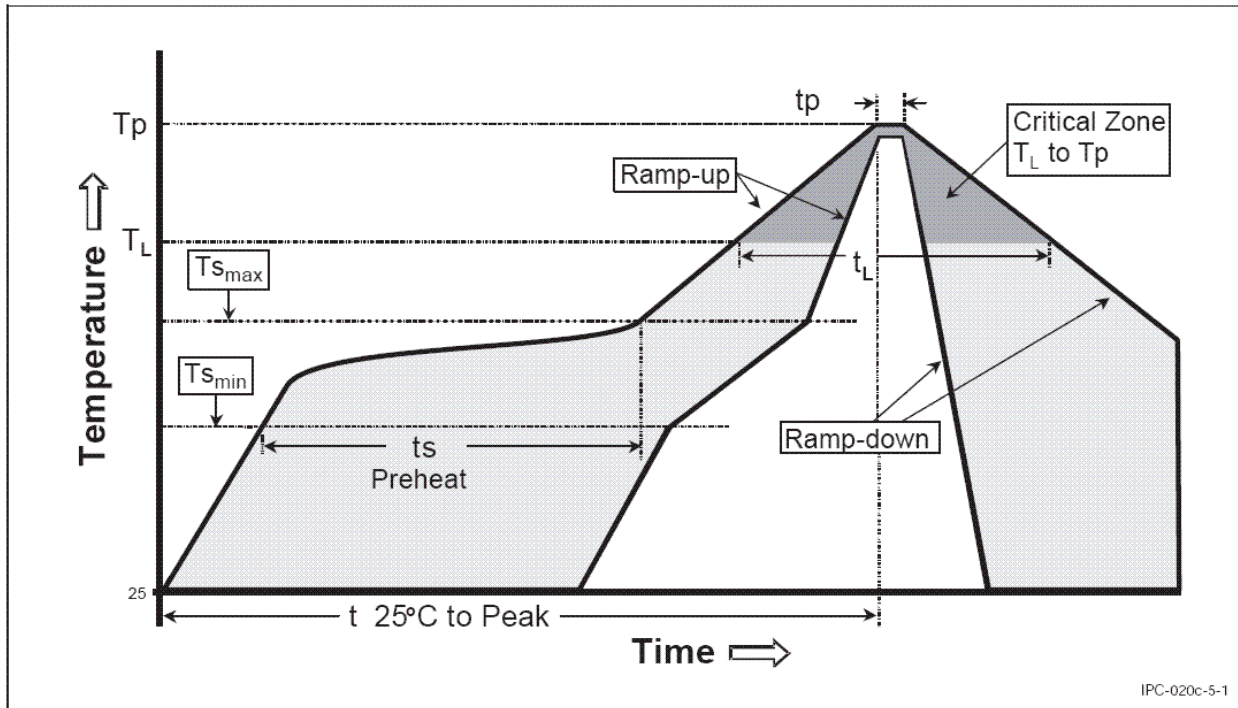

Figure 28 - Classification Reflow Profile (IPC/JEDEC J-STD-020C)

ADVANCED COMMUNICATIONS & SENSING

© Semtech 2009

All rights reserved. Reproduction in whole or in part is prohibited without the prior written consent of the copyright owner. The information presented in this document does not form part of any quotation or contract, is believed to be accurate and reliable and may be changed without notice. No liability will be accepted by the publisher for any consequence of its use. Publication thereof does not convey nor imply any license under patent or other industrial or intellectual property rights. Semtech assumes no responsibility or liability whatsoever for any failure or unexpected operation resulting from misuse, neglect improper installation, repair or improper handling or unusual physical or electrical stress including, but not limited to, exposure to parameters beyond the specified maximum ratings or operation outside the specified range.

SEMTECH PRODUCTS ARE NOT DESIGNED, INTENDED, AUTHORIZED OR WARRANTED TO BE SUITABLE FOR USE IN LIFE-SUPPORT APPLICATIONS, DEVICES OR SYSTEMS OR OTHER CRITICAL APPLICATIONS. INCLUSION OF SEMTECH PRODUCTS IN SUCH APPLICATIONS IS UNDERSTOOD TO BE UNDERTAKEN SOLELY AT THE CUSTOMER'S OWN RISK. Should a customer purchase or use Semtech products for any such unauthorized application, the customer shall indemnify and hold Semtech and its officers, employees, subsidiaries, affiliates, and distributors harmless against all claims, costs damages and attorney fees which could arise.

Contact Information

Semtech Corporation
Advanced Communications and Sensing Products Division
200 Flynn Road, Camarillo, CA 93012
Phone: (805) 498-2111 Fax: (805) 498-3804