

Stereo ADC with Microphone Preamplifier

DESCRIPTION

The WM8737L is a low power stereo audio ADC designed specifically for portable applications such as minidisc and memory audio / voice recorders.

The device offers three sets of stereo inputs, which can be configured for line-level signals, for internal or table-top microphones, or for DC measurement (battery monitor). A programmable gain amplifier can be used for automatic level control (ALC) with user programmable hold, attack and decay times. The device also has a selectable high pass filter to remove residual DC offsets.

If the signal source is mono, the WM8737L can run in mono mode, saving power. It can also mix two channels to mono, either in the analogue or the digital domain.

Master or slave mode clocking schemes are offered. Stereo 24-bit multi-bit sigma-delta ADCs are used with digital audio output word lengths from 16-32 bits, and sampling rates from 8kHz to 96kHz supported.

The device is controlled via a 2 or 3 wire serial interface. The interface provides access to all features including gain controls, analogue or digital mono mixing, and power management facilities. The device is supplied in a leadless 5x5mm QFN package.

FEATURES

- SNR 97dB ('A' weighted @ 3.3V, 48kHz, normal power mode)
- THD -84dB (at -1dB, 3.3V, normal power mode)
- Complete Stereo / Mono Microphone Interface
 - Programmable microphone preamp
 - Automatic Level Control
 - Low-noise microphone bias voltage
- Configurable Power / Performance
- Low Power Mode
 - 8.5mW at AVDD = 1.8V (stereo, mic preamps off)
 - 20mW at AVDD = 3.3V (stereo, mic preamps off)
- Low Supply Voltages
 - Analogue 1.8V to 3.6V
 - Digital core: 1.42V to 3.6V
 - Digital I/O: 1.8V to 3.6V
- 256fs / 384fs or USB master clock rates: 12MHz, 24MHz
- Audio sample rates: 8, 11.025, 12, 16, 22.05, 24, 32, 44.1, 48, 88.2, 96kHz generated internally from master clock
- 32-pin QFN package, 5 x 5 x 0.9mm

APPLICATIONS

- Memory Audio / Voice Recorders
- Minidisc Recorders
- Portable Digital Music Systems

BLOCK DIAGRAM

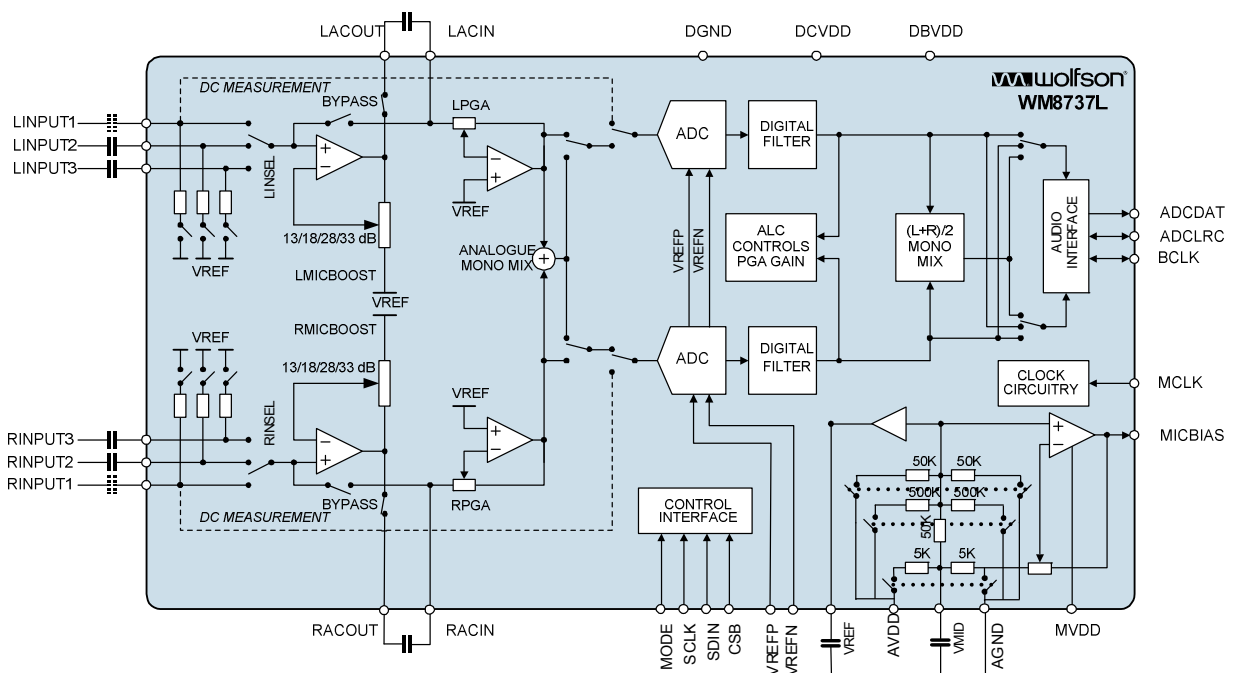
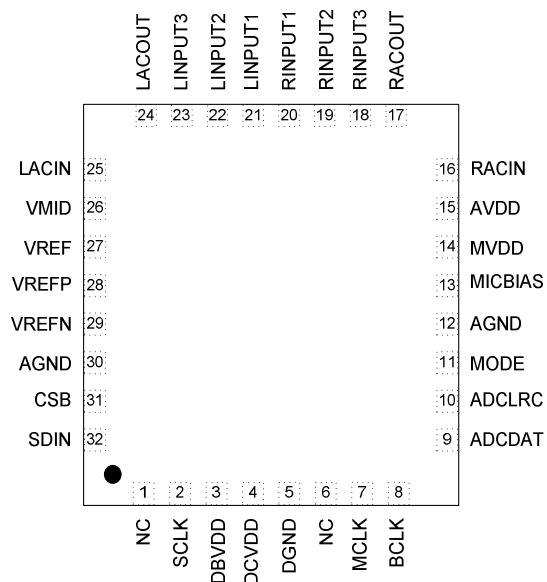

TABLE OF CONTENTS

DESCRIPTION	1
FEATURES.....	1
APPLICATIONS	1
BLOCK DIAGRAM	1
TABLE OF CONTENTS	2
PIN CONFIGURATION.....	3
ORDERING INFORMATION	3
PIN DESCRIPTION	4
ABSOLUTE MAXIMUM RATINGS	5
RECOMMENDED OPERATING CONDITIONS	5
ELECTRICAL CHARACTERISTICS	6
TERMINOLOGY.....	8
POWER CONSUMPTION	9
SIGNAL TIMING REQUIREMENTS	11
DEVICE DESCRIPTION	14
INTRODUCTION.....	14
INPUT SIGNAL PATH.....	14
ANALOGUE TO DIGITAL CONVERTER (ADC)	19
3D STEREO ENHANCEMENT.....	20
AUTOMATIC LEVEL CONTROL (ALC)	21
DIGITAL AUDIO INTERFACE.....	24
MASTER CLOCK AND AUDIO SAMPLE RATES	28
CONTROL INTERFACE	30
POWER SUPPLIES.....	31
POWER MANAGEMENT	31
REGISTER MAP.....	32
DIGITAL FILTER CHARACTERISTICS	33
TERMINOLOGY.....	33
APPLICATIONS INFORMATION	35
LINE INPUT CONFIGURATION.....	35
MICROPHONE INPUT CONFIGURATION	35
RECOMMENDED EXTERNAL COMPONENTS	36
PACKAGE DIMENSIONS	37
IMPORTANT NOTICE	38
ADDRESS:.....	38

PIN CONFIGURATION



ORDERING INFORMATION

ORDER CODE	TEMPERATURE RANGE	PACKAGE	MOISTURE SENSITIVITY LEVEL	PEAK SOLDERING TEMPERATURE
WM8737LGEFL	-25°C to +85°C	32-pin QFN (5x5x0.9mm) lead free	MSL1	260°C
WM8737LGEFL/R	-25°C to +85°C	32-pin QFN (5x5x0.9mm) lead free, tape and reel	MSL1	260°C

Note:

Reel Quantity = 3,500

PIN DESCRIPTION

PIN NO	NAME	TYPE	DESCRIPTION
1	NC	No Connect	No Internal Connection
2	SCLK	Digital Input	Control Interface Clock Input
3	DBVDD	Supply	Digital Buffer (I/O) Supply
4	DCVDD	Supply	Digital Core Supply
5	DGND	Supply	Digital Ground (return path for both DCVDD and DBVDD)
6	NC	No Connect	No Internal Connection
7	MCLK	Digital Input	Master Clock
8	BCLK	Digital Input / Output	Audio Interface Bit Clock
9	ADCDAT	Digital Output	ADC Digital Audio Data
10	ADCLRC	Digital Input / Output	Audio Interface Left / Right Clock
11	MODE	Digital Input	Control Interface Selection
12	AGND	Supply	Analogue Ground (return path for both AVDD and MVDD)
13	MICBIAS	Analogue Output	Microphone Bias
14	MVDD	Supply	Microphone Bias and Microphone Pre-amplifier Positive Supply
15	AVDD	Supply	Analogue Positive Supply
16	RACIN	Analogue Input	Right Channel DC Blocking Capacitor
17	RACOUT	Analogue Output	Right Channel DC Blocking Capacitor
18	RINPUT3	Analogue Input	Right Channel Input 3
19	RINPUT2	Analogue Input	Right Channel Input 2
20	RINPUT1	Analogue Input	Right Channel Input 1
21	LINPUT1	Analogue Input	Left Channel Input 1
22	LINPUT2	Analogue Input	Left Channel Input 2
23	LINPUT3	Analogue Input	Left Channel Input 3
24	LACOUT	Analogue Output	Left Channel DC Blocking Capacitor
25	LACIN	Analogue Input	Left Channel DC Blocking Capacitor
26	VMID	Analogue Output	Midrail Voltage Decoupling Capacitor
27	VREF	Analogue Output	Reference Voltage Decoupling Capacitor
28	VREFP	Analogue Output	Positive Reference Decoupling Connection
29	VREFN	Analogue Output	Negative Reference Decoupling Connection
30	AGND	Supply	Analogue Ground (return path for both AVDD and MVDD)
31	CSB	Digital Input	Chip Select / Device Address Selection
32	SDIN	Digital Input / Output	Control Interface Data Port

ABSOLUTE MAXIMUM RATINGS

Absolute Maximum Ratings are stress ratings only. Permanent damage to the device may be caused by continuously operating at or beyond these limits. Device functional operating limits and guaranteed performance specifications are given under Electrical Characteristics at the test conditions specified.



ESD Sensitive Device. This device is manufactured on a CMOS process. It is therefore generically susceptible to damage from excessive static voltages. Proper ESD precautions must be taken during handling and storage of this device.

Wolfson tests its package types according to IPC/JEDEC J-STD-020B for Moisture Sensitivity to determine acceptable storage conditions prior to surface mount assembly. These levels are:

MSL1 = unlimited floor life at <30°C / 85% Relative Humidity. Not normally stored in moisture barrier bag.

MSL2 = out of bag storage for 1 year at <30°C / 60% Relative Humidity. Supplied in moisture barrier bag.

MSL3 = out of bag storage for 168 hours at <30°C / 60% Relative Humidity. Supplied in moisture barrier bag.

CONDITION	MIN	MAX
Supply voltages	-0.3V	+3.63V
Voltage range digital inputs	DGND -0.3V	DBVDD +0.3V
Voltage range analogue inputs	AGND -0.3V	AVDD +0.3V
Voltage range LACIN, RACIN, LACOUT, RACOUT, MICBIAS	AGND -0.3V	MVDD +0.3V
Master Clock Frequency		40MHz
Operating temperature range, T _A	-25°C	+85°C
Storage temperature after soldering	-65°C	+150°C

Notes:

1. Analogue and digital grounds must always be within 0.3V of each other.
2. All digital and analogue supplies are completely independent from each other.

RECOMMENDED OPERATING CONDITIONS

PARAMETER	SYMBOL	TEST CONDITIONS	MIN	TYP	MAX	UNIT
Digital supply range (Core)	DCVDD		1.42		3.6	V
Digital supply range (I/O Buffers)	DBVDD		1.8		3.6	V
Analogue supplies range	AVDD, MVDD		1.8		3.6	V
Ground	DGND, AGND			0		V

Notes:

1. DBVDD must be greater than or equal to DCVDD.

ELECTRICAL CHARACTERISTICS**Test Conditions**

DCVDD = 1.5V, AVDD = MVDD = 3.3V, T_A = +25°C, 1kHz -1dBFS signal, Normal Power Mode, fs = 48kHz, PGA gain = 0dB, 24-bit audio data, unless otherwise stated. Microphone preamplifier at maximum bias (default) and gain 13dB, unless otherwise stated.

PARAMETER	SYMBOL	TEST CONDITIONS	MIN	TYP	MAX	UNIT
Microphone Preamplifier (LINPUT1/2/3, RINPUT1/2/3) to ADC						
Microphone Pre-amp (Boost) Gain		MICBOOST = 00		13		dB
		MICBOOST = 01		18		
		MICBOOST = 10		28		
		MICBOOST = 11		33		
Microphone preamplifier noise (referred to input) (A-weighted)		Voltage at 1kHz Micboost gain = 28dB		6		nV / √Hz
		at 20Hz – 20kHz Micboost gain = 28dB		0.7 -123		μV rms dBV
Input Offset Voltage				1		mV
Microphone preamplifier Signal to Noise Ratio (A-weighted) (Note 1)	SNR	AVDD = 3.3V 600Ω R _{source}		109		dB
		AVDD=1.8V 600Ω R _{source}		102		
		28 dB gain, AVDD = 3.3V 600Ω R _{source}		94		
Dynamic Range (Note 2)	DNR	A-weighted, -60dBFS Gain = 0dB		94		dB
Total Harmonic Distortion (Note 3)	THD	13dB gain, AVDD = 3.3V, Single Channel		-74 0.02		dB %
		13dB gain, AVDD=1.8V, Single Channel		-70 0.03		
Channel Separation				-65		dB
Power Supply Rejection Ratio	PSRR	1kHz, 100mV pk-pk,		60		dB
Input Leakage		Microphone preamplifier enabled	-10	1	10	μA
Input Resistance	Ω			500k		Ω

Test Conditions

DCVDD = 1.5V, AVDD = MVDD = 3.3V, T_A = +25°C, 1kHz -1dBFS signal, Normal Power Mode, fs = 48kHz, PGA gain = 0dB, 24-bit audio data, unless otherwise stated.

PARAMETER	SYMBOL	TEST CONDITIONS	MIN	TYP	MAX	UNIT
Line Inputs (LINPUT1/2/3, RINPUT1/2/3) to ADC – MIC pre-amp BYPASSED						
Full Scale Input Signal Level (for ADC 0dB Input at 0dB Gain)		AVDD = 3.3V		1.0		V rms
		AVDD = 1.8V		0.545		
Signal to Noise Ratio (A-weighted) (Note 1)	SNR	AVDD = 3.3V, Normal Power Mode	90	97		dB
		AVDD = 2.7V, Normal Power Mode		95		
		AVDD = 1.8V, Normal Power Mode		92		
		AVDD = 3.3V, Low Power Mode		95		
		AVDD = 2.7V, Low Power Mode		93		
		AVDD = 1.8V, Low Power Mode		90		
Dynamic Range (A-weighted) (Note 2)	DNR	-60dBFS, Normal Power Mode	90	97		dB
		-60dBFS, Low Power Mode		95		
Total Harmonic Distortion (Note 3)	THD	-1dB input		-84 (0.006%)		dB %
		-1dB input, AVDD=1.8V		-81 (0.009%)		
ADC Channel Separation (Note 4)		1kHz signal		105		dB
Channel Matching		1kHz signal		0.2		dB
Programmable Gain Amplifier (PGA)						
Programmable Gain			-97	0	30	dB
Programmable Gain Step Size		Monotonic		0.5		dB
Gain Error (Deviation from ideal 0.5dB/step gain characteristic)		1kHz signal	-0.3		0.3	dB
Input Resistance		0dB gain		30		kΩ
		30dB gain		1.9		
Input Capacitance				16.9pF		pF
Automatic Level Control (ALC)						
Typical Record Level			-18		-3	dB
Gain Hold Time (Note 5)	t _{HLD}	MCLK = 12.288MHz (Note 3)	0, 2.67, 5.33, 10.67, ... , 43691 (time doubles with each step)			ms
Gain Ramp-Up (Decay) Time (Notes 6, 7)	t _{DCY}		33.6, 67.2, 134.4, ... , 3441 (time doubles with each step)			ms
Gain Ramp-Down (Attack) Time (Notes 6, 7)	t _{ATK}		8.4, 16.8, 33.6, ... , 8600 (time doubles with each step)			ms

Test Conditions

DCVDD = 1.5V, AVDD = MVDD = 3.3V, T_A = +25°C, 1kHz -1dBFS signal, Normal Power Mode, fs = 48kHz, PGA gain = 0dB, 24-bit audio data, unless otherwise stated.

PARAMETER	SYMBOL	TEST CONDITIONS	MIN	TYP	MAX	UNIT
Analogue Reference Levels						
Mid-rail Reference Voltage	VMID		-3%	AVDD/2	+3%	V
VMID Output Resistance	R _{VMID}			75		kΩ
Buffered Reference Voltage	VREF		-3%	AVDD/2	+3%	V
Microphone Bias						
Bias Voltage	V _{MICBIAS}	MICBIAS = 01		0.75×AVDD		V
		MICBIAS = 10	0.9×AVDD -3%	0.9×AVDD	0.9×AVDD +3%	V
		MICBIAS = 11, AVDD = 2.5V		1.2×AVDD		V
Bias Current Source	I _{MICBIAS}				3	mA
Output Noise Voltage	V _n	1K to 20kHz		24		nV/√Hz
Digital Input / Output						
Input HIGH Level	V _{IH}		0.7×DBVDD			V
Input LOW Level	V _{IL}				0.3×DBVDD	V
Output HIGH Level	V _{OH}	I _{OH} = 1mA	0.9×DBVDD			V
Output LOW Level	V _{OL}	I _{OL} = -1mA			0.1×DBVDD	V

TERMINOLOGY

- Signal-to-noise ratio (dB) – for the microphone preamplifiers, quoted SNR is the ratio of the rms voltages of the full-scale output at the L/RACOUT pins and the noise observed at these pins with no input signals. This figure indicates only the microphone preamplifier noise and does **not** account for additional noise that will be added by the PGAs and ADCs in obtaining the final digitised result. For the line inputs, quoted SNR is the ratio of the rms code ranges as measured at the ADC output for a full-scale output signal and the noise observed with no input. This figure combines the PGA and ADC noise contributions. (No Auto-zero or Auto-mute function is employed in achieving these results).
- Dynamic range (dB) - DR measures the ratio in the ADC output between the full-scale signal power and all power contributed by noise and spurious tones in the specified bandwidth. Normally THD+N is measured at 60dB below full scale (to reduce any distortion components to negligible levels) and the measurement is then corrected by adding the 60dB to its magnitude. (e.g. THD+N @ -60dB = -32dB, DR = 60 + |-32| = 92dB).
- Total Harmonic Distortion and Noise (dB) - THD+N is a ratio of the rms values of (Noise + Distortion) and Signal.
- Channel Separation (dB) - Also known as Cross-Talk. This is a measure of the amount one channel is isolated from the other. Normally measured by sending a full scale signal down one channel and measuring how much of this signal appears at the output of the other channel.
- Hold Time is the length of time between a signal detected by the ALC as being too quiet and beginning to ramp up the gain. It does not apply to ramping down the gain when the signal is too loud, which happens without a delay.
- Ramp-up and Ramp-Down times are defined as the time it takes for the PGA to sweep across 90% of its gain range.
- All hold, ramp-up and ramp-down times scale proportionally with MCLK

Notes:

- All performance measurements are done with a 20kHz low pass filter, and where noted an A-weight filter. Failure to use such a filter will result in higher THD+N and lower SNR and Dynamic Range readings than are found in the Electrical Characteristics. The low pass filter removes out of band noise; although this is not audible, it may affect dynamic specification values.
- VMID and VREF are each to be decoupled to a clean analogue ground with 10uF and 0.1uF capacitors placed as close to the device package as possible. Smaller capacitors may reduce performance. VREFP should be connected to VREF and VREFN should be connected to AGND using short PCB traces. It is not recommended to connect other components to VMID or VREF in case of noise injection to the internal references of the device.

POWER CONSUMPTION

The power consumption of the WM8737L depends on the following factors.

- Supply voltages: Reducing the supply voltages also reduces supply currents, and therefore results in significant power savings (at the cost of reduced maximum SNR and THD performance).
- Operating mode: Power consumption is lower when microphone pre-amps are not used. It can be also reduced in mono or analogue mix-to-mono modes by switching off unused PGAs and ADCs via the power management register.

MODE DESCRIPTION	POWER MANAGEMENT REGISTER SETTING	TYP. SUPPLY CURRENTS (MILLIAMPS)			TOTAL POWER (mW)
		I _{AVDD}	I _{DBVDD}	I _{DCVDD}	
MVDD = 1.8V, AVDD = 1.8V, DBVDD = 1.8V, DCVDD = 1.5V, Low Power Mode, no MICBIAS or mic preamps					
OFF	00000000	0.000	0.000	0.007	0.011
Standby	11000000	0.692	0.004	0.009	1.356
Mono (L/R)	111101000 / 111010100	1.978	0.011	1.633	6.029
Stereo / Digital Mono Mix	111111100	3.205	0.018	1.666	8.299
Analogue mono mix (without dc monitoring via Right ADC)	111111000	2.543	0.017	1.640	6.537
Analogue mono mix (with continuous dc monitoring via Right ADC)	111111100	3.205	0.018	1.670	8.306
Using MICBIAS in 0.9 X AVDD mode in addition to any of the above	Set appropriate MICBIAS[1:0] bits in power management register	+0.255	-	-	+0.459
Using microphone boost preamplifiers in addition to any of the above	Set appropriate MBCTRL[1:0] bits in register 09h and set LMBE and/or RMBE bits in registers 02h and 03h	+0.692	-	-	+1.688
MVDD = 3.3V, AVDD = 3.3V, DBVDD = 3.3V, DCVDD = 1.5V, Low Power Mode, no MICBIAS or mic preamps					
OFF	00000000	0.000	0.000	0.007	0.011
Standby	11000000	1.288	0.007	0.064	0.117
Mono (L/R)	111101000 / 111010100	2.993	0.018	1.624	12.173
Stereo / Digital Mono Mix	111111100	4.453	0.031	1.650	17.273
Analogue mono mix (without dc monitoring via Right ADC)	111111000	3.684	0.018	1.620	14.648
Analogue mono mix (with continuous dc monitoring via Right ADC)	111111100	4.453	0.031	1.660	17.288
Using MICBIAS in 0.9 X AVDD mode in addition to any of the above	Set appropriate MICBIAS[1:0] bits in power management register	+0.47	-	-	+1.551
Using microphone boost preamplifiers in addition to any of the above	Set appropriate MBCTRL[1:0] bits in register 09h and set LMBE and/or RMBE bits in registers 02h and 03h	+1.413	-	-	+4.663

MVDD = 1.8V, AVDD = 1.8V, DBVDD = 1.8V, DCVDD = 1.5V, Normal Power Mode, no MICBIAS or mic preamps					
OFF	00000000	0.000	0.000	0.007	0.011
Standby	11000000	0.698	0.004	0.069	1.367
Mono (L/R)	111101000 / 111010100	3.453	0.010	1.910	9.098
Stereo / Digital Mono Mix	111111100	6.109	0.017	1.955	13.959
Analogue mono mix (without dc monitoring via Right ADC)	111111000	4.574	0.010	1.910	11.116
Analogue mono mix (with continuous dc monitoring via Right ADC)	111111100	6.109	0.017	1.940	13.937
Using MICBIAS in 0.9 X AVDD mode in addition to any of the above	Set appropriate MICBIAS[1:0] bits in power management register	+0.252	-	-	+0.454
Using microphone boost preamplifiers in addition to any of the above	Set appropriate MBCTRL[1:0] bits in register 09h and set LMBE and/or RMBE bits in registers 02h and 03h	+0.738	-	-	+1.328
MVDD = 3.3V, AVDD = 3.3V, DBVDD = 3.3V, DCVDD = 1.5V, Normal Power Mode, no MICBIAS or mic preamps					
OFF	00000000	0.001	0.000	0.007	0.014
Standby	11000000	1.288	0.007	0.064	4.371
Mono (L/R)	111101000 / 111010100	4.632	0.020	1.905	18.210
Stereo / Digital Mono Mix	111111100	7.750	0.032	1.950	28.606
Analogue mono mix (without dc monitoring via Right ADC)	111111000	5.996	0.020	1.890	22.688
Analogue mono mix (with continuous dc monitoring via Right ADC)	111111100	7.750	0.033	1.960	28.624
Using MICBIAS in 0.9 X AVDD mode in addition to any of the above	Set appropriate MICBIAS[1:0] bits in power management register	+0.446	-	-	+1.472
Using microphone boost preamplifiers in addition to any of the above	Set appropriate MBCTRL[1:0] bits in register 09h and set LMBE and/or RMBE bits in registers 02h and 03h	+1.406	-	-	+4.640

Table 1 Supply Current Consumption (see also "Power Management" section)

Notes:

1. $T_A = +25^{\circ}\text{C}$, Slave Mode, $f_s = 48\text{kHz}$, $\text{MCLK} = 12.288\text{ MHz}$ (256fs), 24-bit data
2. All figures are quiescent, with no signal.

SIGNAL TIMING REQUIREMENTS

SYSTEM CLOCK TIMING

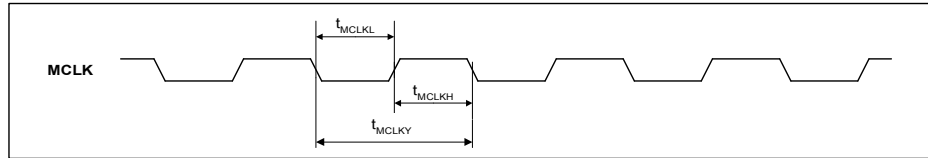

Figure 1 System Clock Timing Requirements

Test Conditions

DBVDD = 3.3V, DCVDD = 1.42 to 3.6V, DGND = 0V, $T_A = +25^\circ\text{C}$, Slave Mode $f_s = 48\text{kHz}$, MCLK = 256fs, 24-bit data, unless otherwise stated.

PARAMETER	SYMBOL	MIN	TYP	MAX	UNIT
System Clock Timing Information					
MCLK System clock pulse width high	T_{MCLKL}	13			ns
MCLK System clock pulse width low	T_{MCLKH}	13			ns
MCLK System clock cycle time	T_{MCLKY}	26			ns

AUDIO INTERFACE TIMING – MASTER MODE

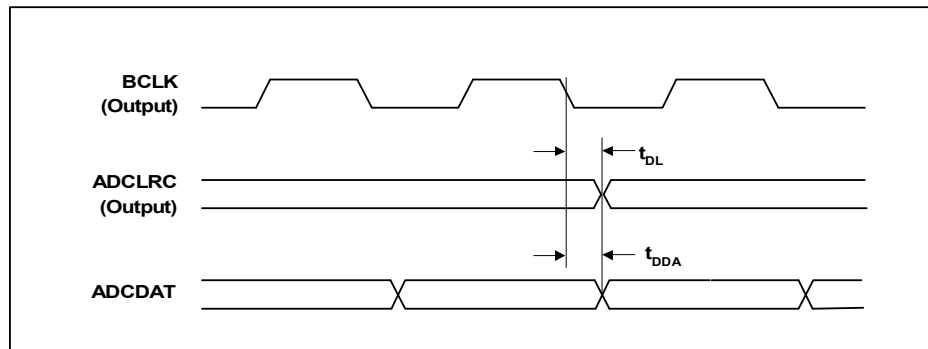

Figure 2 Digital Audio Data Timing – Master Mode (see Control Interface)

Test Conditions

DBVDD = 3.3V, DCVDD = 1.42 to 3.6V, DGND = 0V, $T_A = +25^\circ\text{C}$, Slave Mode, $f_s = 48\text{kHz}$, MCLK = 256fs, 24-bit data, unless otherwise stated.

PARAMETER	SYMBOL	MIN	TYP	MAX	UNIT
Audio Data Input Timing Information					
ADCLRC propagation delay from BCLK falling edge	t_{DL}	0		10	ns
ADCDAT propagation delay from BCLK falling edge	t_{DDA}	0		10	ns

AUDIO INTERFACE TIMING – SLAVE MODE

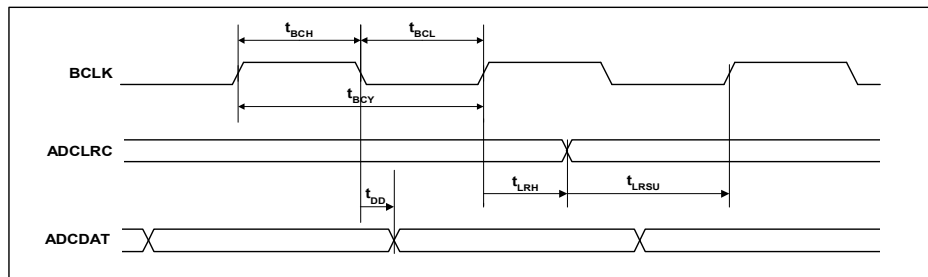

Figure 3 Digital Audio Data Timing – Slave Mode

Test Conditions

DBVDD = 3.3V, DCVDD = 1.42 to 3.6V, DGND = 0V, T_A = +25°C, Slave Mode, fs = 48kHz, MCLK = 256fs, 24-bit data, unless otherwise stated.

PARAMETER	SYMBOL	MIN	TYP	MAX	UNIT
Audio Data Input Timing Information					
BCLK cycle time	t _{BCY}	50			ns
BCLK pulse width high	t _{BCH}	20			ns
BCLK pulse width low	t _{BCL}	20			ns
ADCLRC set-up time to BCLK rising edge	t _{LRSU}	10			ns
ADCLRC hold time from BCLK rising edge	t _{LRH}	10			ns
ADCDAT propagation delay from BCLK falling edge	t _{DD}	0		10	ns

CONTROL INTERFACE TIMING – 3-WIRE MODE

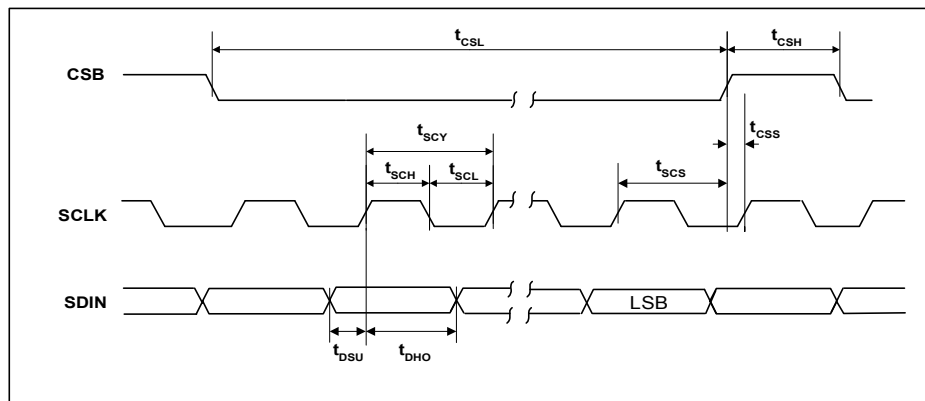

Figure 4 Control Interface Timing – 3-Wire Serial Control Mode

Test Conditions

DBVDD = 3.3V, DCVDD = 1.42 to 3.6V, DGND = 0V, T_A = +25°C, Slave Mode, fs = 48kHz, MCLK = 256fs, 24-bit data, unless otherwise stated.

PARAMETER	SYMBOL	MIN	TYP	MAX	UNIT
Program Register Input Information					
SCLK rising edge to CSB rising edge	t _{SCS}	40			ns
SCLK pulse cycle time	t _{SCY}	80			ns
SCLK pulse width low	t _{SCL}	40			ns
SCLK pulse width high	t _{SCH}	40			ns
SDIN to SCLK set-up time	t _{DSU}	10			ns
SCLK to SDIN hold time	t _{DHO}	10			ns
CSB pulse width low	t _{CSL}	10			ns
CSB pulse width high	t _{CSH}	10			ns
CSB rising to SCLK rising	t _{CSS}	10			ns
Pulse width of spikes which will be suppressed	t _{SP}	0		5	ns

CONTROL INTERFACE TIMING – 2-WIRE MODE

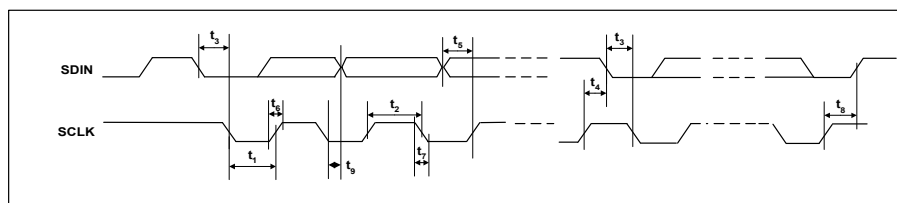

Figure 5 Control Interface Timing – 2-Wire Serial Control Mode

Test Conditions

DBVDD = 3.3V, DCVDD = 1.42 to 3.6V, DGND = 0V, T_A = +25°C, Slave Mode, f_s = 48kHz, MCLK = 256fs, 24-bit data, unless otherwise stated.

PARAMETER	SYMBOL	MIN	TYP	MAX	UNIT
Program Register Input Information					
SCLK Frequency		0		400	kHz
SCLK Low Pulse-Width	t ₁	1.3			us
SCLK High Pulse-Width	t ₂	600			ns
Hold Time (Start Condition)	t ₃	600			ns
Setup Time (Start Condition)	t ₄	600			ns
Data Setup Time	t ₅	100			ns
SDIN, SCLK Rise Time	t ₆			300	ns
SDIN, SCLK Fall Time	t ₇			300	ns
Setup Time (Stop Condition)	t ₈	600			ns
Data Hold Time	t ₉			900	ns

DEVICE DESCRIPTION

INTRODUCTION

The WM8737L is a low power analogue to digital converter (ADC) designed for audio recording. Its features, performance and low power consumption make it ideal for recordable CD players, MP3 players, portable MD players and PDAs.

The device includes three stereo analogue inputs with a multiplexer to select between inputs. Each input can be used as either a line level input or as a microphone input with on-chip microphone pre-amplifiers. A programmable gain amplifier provides additional gain or attenuation, and can be used for automatic level control (ALC), keeping the recording volume constant. It is also possible to use the WM8737L as a mono device, or to mix the two channels to mono, either in the analogue or in the digital domain.

The ADC is of a high quality using a multi-bit high-order oversampling architecture delivering high SNR at low power consumption. It can operate at oversampling rates of 64fs (low power mode) or 128fs (normal power mode), allowing users to design for low power consumption or high performance. The ADC also includes a digital high pass filter to remove unwanted DC components from the audio signal. This filter may be turned off for DC measurements.

The output from the ADC is available on a configurable digital audio interface. It supports a number of audio data formats including I²S, DSP Mode, Left justified and Right justified, and can operate in master or slave modes.

The WM8737L master clock can be either an industry standard 256/384 f_s clock or a 12MHz/24MHz USB clock. Sample rates of 8kHz, 11.025kHz, 12kHz, 16kHz, 22.05kHz, 24kHz, 32kHz, 44.1kHz, 48kHz, 88.2kHz and 96kHz can be generated directly from the master clock, without an external PLL. The digital filters are optimised for each sample rate.

The WM8737L can be controlled through a 2 wire or 3 wire MPU control interface. It is fully compatible and an ideal partner for a range of industry standard microprocessors, controllers and DSPs.

The design of the WM8737L has minimised power consumption without compromising performance. It can operate at very low voltages, can power off parts of the circuitry under software control and includes standby and power off modes.

INPUT SIGNAL PATH

The signal path consists of a multiplexer switch to select between three sets of analogue inputs, followed by a microphone boost preamplifier with selectable gain settings of 13dB, 18dB, 28dB and 33dB.

The microphone preamplifier feeds into a PGA (programmable gain amplifier) via an external capacitor which removes dc offsets that could otherwise produce zipper noise when the PGA gain changes. Alternatively, for line input signals, the microphone preamplifier can be bypassed to reduce power consumption and noise. The PGA gain can be controlled either by the user or by the on-chip ALC function (see Automatic Level Control).

The output signal from each PGA (left and right) enters an ADC where it is digitised. The two channels can also be mixed in the analogue domain and digitised in one ADC while the other ADC is switched off to reduce power consumption (see "Power Management" section). The mono-mix signal appears on both digital output channels.

LEFT AND RIGHT CHANNEL SIGNAL INPUTS

The WM8737L has two sets of low capacitance ac coupled analogue inputs, LINPUT1, LINPUT2, LINPUT3 and RINPUT1, RINPUT2, RINPUT3. The LINSEL and RINSEL control bits select between them. These inputs can be configured as microphone or line inputs by enabling or disabling the microphone preamplifier. All inputs have high impedance when the preamplifier is used and their impedance is between 1.8k Ω and 50k Ω (depending on PGA gain) if the preamplifier is bypassed.

The microphone preamplifier has very high gain settings. Care should be taken to prevent the input signal to the microphone preamplifier from exceeding the supply rails which will saturate the microphone preamplifier and may cause the preamplifier to oscillate. This is more likely to happen at the higher gain settings of +28dB and +33dB. The input signal should be limited to prevent the input signal from exceeding the supply rails and saturating the microphone preamplifier.

The signal inputs are internally high-impedance biased to the reference voltage, VREF. Whenever line inputs are muted or the device is placed into standby mode 2 (see “Power Management” section), the inputs stay biased to VREF. This reduces any audible clicks that may otherwise be heard when changing inputs or awakening from standby.

DC MEASUREMENT

For dc measurements (battery voltage monitoring for example), the LINPUT1 and/or RINPUT1 pins can be taken directly into the respective ADC, bypassing the microphone preamplifier and PGA.

In dc mode the ADC output is mid-scale for L/RINPUT1 voltage AGND and full-scale for L/RINPUT voltage $1.7 \times AVDD$. Note that L/RINPUT1 must not exceed AVDD and so a voltage divider will be required to bring the battery voltage into range.

REGISTER ADDRESS	BIT	LABEL	DEFAULT	DESCRIPTION
R2 (02h) Analogue Audio Path Control (Left Channel)	8:7	LINSEL	00	Left Channel Input Select 00: LINPUT1 01: LINPUT2 10: LINPUT3 11: dc measure on LINPUT1
	6:5	LMICBOOST[1:0]	00	Left Channel Microphone Gain Boost 00: 13dB boost 01: 18dB boost 10: 28dB boost 11: 33dB boost
	4	LMBE	0	Left Channel Mic Boost Enable 0: Mic preamp disabled, bypass switch is closed. 1: Mic preamp is enabled, bypass switch is open.
R3 (03h) Analogue Audio Path Control (Right Channel)	8:7	RINSEL	00	Right Channel Input Select 00: RINPUT1 01: RINPUT2 10: RINPUT3 11: dc measure on RINPUT1
	6:5	RMICBOOST[1:0]	00	Right Channel Microphone Gain Boost Same as LMICBOOST
	4	RMBE	0	Right Channel Mic Boost Enable Same as LMBE

Table 2 Input Software Control

The internal VREF input bias may cause unwanted loading of any potential divider connected to L/RINPUT1 for the purpose of dc measurement. In this case, the internal bias sources can be disabled by setting the appropriate bits of register R10 to zero.

REGISTER ADDRESS	BIT	LABEL	DEFAULT	DESCRIPTION
R10 (0Ah) DC Measure Control	0	RINPUT1 dc BIAS ENABLE	1	0: Disable dc bias to RINPUT1 1: Enable dc bias to RINPUT1
	1	LINPUT1 dc BIAS ENABLE	1	0: Disable dc bias to LINPUT1 1: Enable dc bias to LINPUT1

Table 3 DC Measurement Bias Control

MICROPHONE PREAMPLIFIER BYPASS AND BIAS CONTROL

When the Left or Right microphone preamplifier is disabled the user has two options for driving the corresponding Left or Right PGA.

Default operation is to close a preamplifier bypass switch that connects the PGA input directly to the L/RINPUT1/2/3 multiplexer output.

If the application has only a single left or right line level signal source and hence does not require the multiplexer or microphone preamplifier, then better PGA gain accuracy and THD+N performance are obtained by disabling the multiplexer and bypass switch and driving the PGA directly via the L/RACIN pin. The multiplexer and switch are disabled by setting to zero the appropriate L/RBYPEN bit in register R9. The L/RINPUT1/2/3 pads remain biased to VREF. These bits should be set to 1 if the multiplexer is required (always required when the microphone preamplifier is enabled).

The user can also adjust the microphone preamplifier bias settings to optimise THD+N versus supply current consumption for their application. Default is full bias for best THD+N performance, but the user can reduce the bias to 75%, 50% or 25% of default by programming MBCTRL[1:0] in register R9.

REGISTER ADDRESS	BIT	LABEL	DEFAULT	DESCRIPTION
R9 (09h) Microphone Preamplifiers Control	3	RBYPEN	1	Right channel bypass enable 0: Bypass switch is always open. RINPUT1/2/3 high-impedance biased to AVDD/2. RPGA input is RACIN pin. 1: Close bypass switch when right mic preamp is disabled.
	2	LBYPEN	1	Left channel bypass enable 0: Bypass switch is always open. LINPUT1/2/3 high-impedance biased to AVDD/2. LPGA input is LACIN pin. 1: Close bypass switch when left mic preamp is disabled.
	1:0	MBCTRL[1:0]	11	Bias control for left and right microphone preamplifiers 00: bias 25% 01: bias 50% 10: bias 75% 11: nominal (100%) bias

Table 4 Microphone Preamplifier Control

MONO-MIXING

The WM8737L can operate as a stereo or mono device, or the two channels can be mixed to mono in either the analogue domain (before the ADC) or in the digital domain (after the ADC). In all mono and mono-mix modes unused circuitry can be switched off to save power (see "Power Management" section). 3D stereo enhancement (See "3D Stereo Enhancement" section) is automatically disabled in all mono and mono-mix modes.

In analogue mono-mix mode, the signals are mixed in the Left ADC and the Right ADC automatically switches to dc measurement mode on pin RINPUT1. If dc measurement mode is not required then the Right ADC can be powered down by setting bit 2 (ADCR) in the power management register R6. Note that the high pass filter must be disabled if d.c. measurements are required.

In stereo and mono modes the Left/Right ADC data appear at the corresponding Left/Right Channel outputs. In digital mono-mix mode the mixed data appears on both the Left and Right Channel outputs. In analogue mono-mix mode the MONOUT bit controls whether the Right channel output presents the data from the Right ADC (dc measurement) or a copy of the Left Channel (mixed) output.

REGISTER ADDRESS	BIT	LABEL	DEFAULT	DESCRIPTION
R5 (05h) ADC Control	8:7	MONOMIX[1:0]	00	00: Stereo 01: Analogue Mono-mix 10: Digital Mono-mix 11: Reserved
R5 (05h) ADC Control	1	MONOUT	0	Analogue mono-mix format control 0: Left ADC data appears on Left Channel output and Right ADC data appears on Right Channel Output. 1: Left ADC data appears on both Left and Right channel outputs.

Table 5 Mono Mixing Control

Note: In stereo mode (R5) 00, Bit 1 must always be set to 0.

MICROPHONE BIAS

The MICBIAS output provides a low noise reference voltage suitable for biasing electret type microphones and the associated external resistor biasing network. The output voltage is derived from VREF and is programmable in three steps from $0.75 \times AVDD$ to $1.2 \times AVDD$, as shown below. Supply voltage MVDD must be at least 170mV higher than the desired MICBIAS voltage to ensure correct MICBIAS operation.

REGISTER ADDRESS	BIT	LABEL	DEFAULT	DESCRIPTION
R6 (06h) Power Management	1:0	MICBIAS[1:0]	00	Microphone Bias Control 00: MICBIAS OFF (powered down, high-impedance output) 01: $V_{MICBIAS} = 0.75 \times AVDD$ 10: $V_{MICBIAS} = 0.9 \times AVDD$ 11: $V_{MICBIAS} = 1.2 \times AVDD$

Table 6 MICBIAS Control

The internal MICBIAS circuitry is shown below. MVDD is a separate power supply pin used only for MICBIAS and the microphone preamplifiers. When $MICBIAS < AVDD$, then MVDD can be tied to AVDD. However, when $MICBIAS = 1.2 \times AVDD$, then MVDD must be large enough to generate this output voltage, i.e. it must be higher than AVDD.

Note: The maximum voltage for MVDD of 3.6V must be observed.

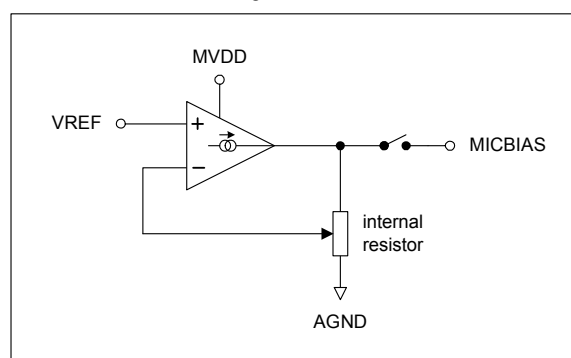
**Figure 6 Microphone Bias Schematic**

Note that the maximum source current capability for MICBIAS is 3mA. The external biasing resistors therefore must be large enough to limit the MICBIAS current to 3mA. Please refer to the "Applications Information" section for recommended external components.

PGA CONTROL

The Left and Right PGAs match the input signal levels to the ADC input ranges. The PGA gain is logarithmically adjustable from -97dB to +30dB in 0.5dB steps. Each PGA can be controlled either by the user or by the ALC function (see "Automatic Level Control" section). When ALC is enabled for one or both channels then writing to the corresponding PGA gain control register has no effect. The gain is independently adjustable on both Right and Left Line Inputs. By setting the LVU or RVU bits whilst programming the PGA gain, both channels can be simultaneously updated. The inputs can also be muted under software control. The PGA control register maps are shown in Table 7.

REGISTER ADDRESS	BIT	LABEL	DEFAULT	DESCRIPTION
R0 (00h) Left Channel PGA	7:0	LINVOL[7:0]	C3h (0dB)	Left Channel Input Volume Control 00000000: MUTE 00000001: -97dB 00000010: -96.5dB ... 11000011: 0dB ... 11111111: +30dB
	8	LVU	0	Left PGA volume update 0: Store LINVOL in left intermediate latch but do not update left gain. 1: Update both PGA gains simultaneously (left gain = LINVOL, right gain = right intermediate latch).
R1 (01h) Right Channel PGA	7:0	RINVOL[7:0]	C3h (0dB)	Right Channel Input Volume Control. Same as LINVOL.
	8	RVU	0	Right PGA volume update 0: Store RINVOL in right intermediate latch but do not update right gain. 1: Update both PGA gains simultaneously (right gain = RINVOL, left gain = left intermediate latch).

Table 7 PGA Software Control**ZERO-CROSS DETECTION**

To avoid zipper or click noises, it is preferable to change the microphone preamplifier and PGA gains only when the input signal is at zero. The WM8737L has built-in zero-cross detectors to achieve this. This function is enabled by setting the LMZC, LPZC, RMZC and RPZC bits. The zero-cross detection feature includes a programmable time-out, selected by writing to LZCTO[1:0] and RZCTO[1:0]. If no zero crossing occurs within the time-out period then the WM8737L changes the PGA or microphone preamplifier gains when the time-out elapses.

REGISTER ADDRESS	BIT	LABEL	DEFAULT	DESCRIPTION
R2 (02h) Audio Path Left	3	LMZC	None (first gain change would overwrite!)	Left Mic preamp Zero-Cross Enable 0: Change gain immediately 1: Change gain on zero crossing only
	2	LPZC	1	Left PGA Zero-Cross Enable 0: Change gain immediately 1: Change gain on zero crossing only
	1:0	LZCTO[1:0]	11	Left Zero-Cross Time-Out 00: 256/fs 01: 512/fs 10: 1024/fs 11: 2048/fs (42.67ms at 48kHz) This timeout applies to both the PGA and mic preamp zero-cross watchdog timers.
R3 (03h) Audio Path Right	3	RMZC	None	Right Mic preamp Zero-Cross Enable Same as LMZC but for right channel
	2	RPZC	1	Right PGA Zero-Cross Enable Same as LMZC but for right channel
	1:0	RZCTO[1:0]	11	Right Zero-Cross Time-Out Same as LMZC but for right channel

Table 8 Zero-Cross Detection Control

ANALOGUE TO DIGITAL CONVERTER (ADC)

The WM8737L uses a multi-bit, oversampled sigma-delta ADC for each channel. The use of multi-bit feedback and high oversampling rates reduces the effects of jitter and high frequency noise. The ADC full-scale input level is proportional to AVDD. With a 3.3V supply voltage the full scale level is 1.0 Volt rms (+/-1.414 Volts peak). Any voltage greater than full-scale will overload the ADC and cause distortion.

ADC THD+N VERSUS POWER CONTROL

The ADCs can be operated in 'normal mode', which offers best THD+N performance at the cost of highest power dissipation, or in 'low power mode' which offers significant power savings at the cost of slightly reduced THD+N performance. The ADCs operating mode is controlled by the LP bit in register R5. USB mode is not compatible with low power mode, so the LP bit must be set to 0 if USB mode is selected.

See the 'Power Consumption' section for power requirements in both modes.

REGISTER ADDRESS	BIT	LABEL	DEFAULT	DESCRIPTION
R5 (05h) ADC Control	2	LP	0	ADC power mode control 0: Both ADCs in normal mode (best THD+N) 1: Both ADCs in low power mode

Table 9 ADC Power Control

ADC DIGITAL FILTER

The ADC filters perform true 24 bit signal processing to convert the raw multi-bit oversampled data from the ADC to the correct sampling frequency to be output on the digital audio interface. The digital filter path is illustrated below.

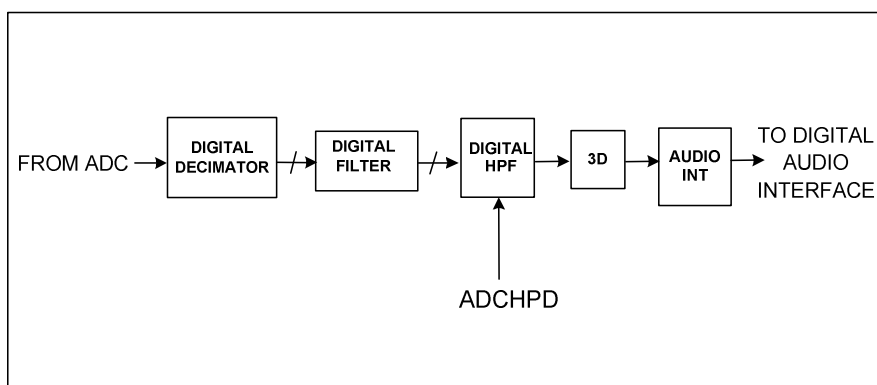

Figure 7 ADC Digital Filter

The ADC digital filters contain a digital high pass filter, selectable via software control. The high-pass filter response is detailed in the “Digital Filter Characteristics” section. When the high-pass filter is enabled the dc offset is continuously calculated and subtracted from the input signal. By setting HPOR, the last calculated d.c. offset value is maintained but still subtracted from the input.

The output data format can be programmed by the user to accommodate stereo or monophonic recording on both inputs. The polarity of the output signal can also be changed under software control. The software control is shown below.

REGISTER ADDRESS	BIT	LABEL	DEFAULT	DESCRIPTION
R5 (05h) ADC Control	0	ADCHPD	0	ADC High Pass Filter Enable (Digital) 1: Disable High Pass Filter 0: Enable High Pass Filter
	4	HPOR	0	Store dc offset 0: Present offset maintained 1: Continuously update offset
	6:5	POLARITY	00	00: Polarity not inverted 01: L polarity invert 10: R polarity invert 11: L and R polarity invert

Table 10 ADC Control

ADC MAXIMUM OUTPUT CODES

The ADC output codes are limited by the digital gain of the stage following the 3D enhancement filters. This limits the max full scale positive output to 7F7FFFh and full scale negative to 808000h. To get the maximum positive output code (7FFFFFFh) and negative code (800000h) from the ADC, the 3D enhancement filters should be bypassed. This can be done by first setting register R13 to 1110xxxx, where xxxx represents the required values for the ALC in the application, and then setting register R28 to 00000100.

Note that the above sequence uses test bits that are not documented and the use of these test bits, other than as described above, is not recommended and is not supported.

3D STEREO ENHANCEMENT

The WM8737L has a 3D stereo enhancement function for use in applications where the natural separation between stereo channels is low. The function is activated by the 3DEN bit, and artificially increases the separation between the left and right channels. The 3DDEPTH setting controls the degree of stereo expansion. Additionally, one of four filter characteristics can be selected for the 3D processing, using the 3DFILT control bits.

When 3D enhancement is enabled (and/or the tone control for playback) it may be necessary to attenuate the signal by 6dB to avoid limiting. This is a user selectable function, enabled by setting DIV2.

Note: The 3D enhancement function will not work properly at sample frequencies of 88.2kHz, 88.235kHz, and 96kHz. When using these sample frequencies the 3D enhancement function should be bypassed by first setting register R13 to 1110xxxx, where xxxx represents the required values for the ALC in the application, and then setting register R28 to 00000100.

Note that the above sequence uses test bits that are not documented and the use of these test bits, other than as described above, is not recommended and is not supported.

REGISTER ADDRESS	BIT	LABEL	DEFAULT	DESCRIPTION
R4 (04h) 3D Control	0	3DEN	0	3D function enable 0: disable 1: enable
	4:1	3DDEPTH[3:0]	0000	Stereo depth 0000: 0% (minimum 3D effect) 0001: 6.67% 1110: 93.3% 1111: 100% (maximum 3D effect)
	5	3DUC	0	Upper Cut-off frequency 0 = High (2.2kHz at 48kHz sampling) 1 = Low (1.5kHz at 48kHz sampling)
	6	3DLC	0	Lower Cut-off frequency 0 = Low (200Hz at 48kHz sampling) 1 = High (500Hz at 48kHz sampling)
	7	DIV2	0	ADC 6dB attenuate enable 0: disabled (0dB) 1: -6dB enabled

Table 11 Stereo Enhancement Control

AUTOMATIC LEVEL CONTROL (ALC)

The WM8737L has an automatic level control that aims to keep a constant recording volume irrespective of the input signal level. This is achieved by continuously adjusting the PGA gain so that the signal level at the ADC input remains constant. A digital peak detector monitors the ADC output and changes the PGA gain if necessary.

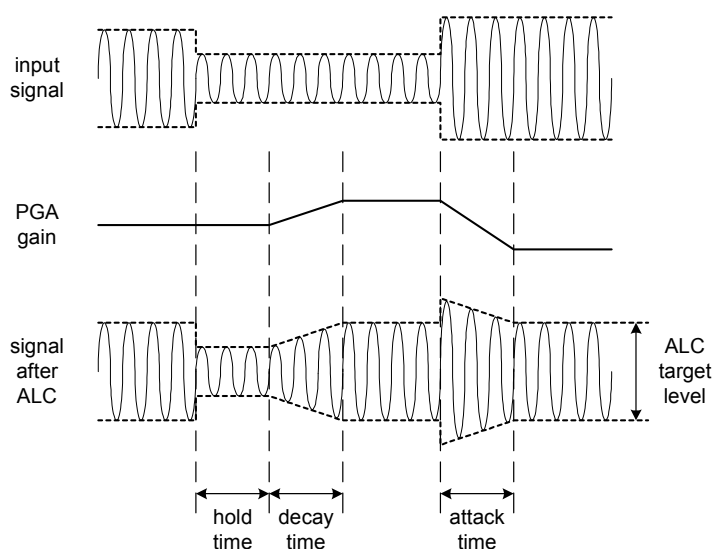

Figure 8 ALC Operation

The ALC function is enabled using the ALCSEL[1:0] control bits in register R12. When enabled, the recording volume can be programmed between -3dB and -18dB (relative to ADC full scale) using the ALCL[3:0] register bits in register R12.

R13 and R14 bits HLD[3:0], DCY[3:0] and ATK[3:0] control the hold, decay and attack times, respectively:

Hold time is the time delay between the peak level detected being below target and the PGA gain beginning to ramp up. It can be programmed in power-of-two (2^n) steps, e.g. 2.67ms, 5.33ms, 10.67ms etc. up to 43.7ms. Alternatively, the hold time can also be set to zero. The hold time only applies to gain ramp-up, there is no delay before ramping the gain down when the signal level is above target.

Decay time (Gain Ramp-Up) is the time that it takes for the PGA gain to ramp up across 90% of its range (e.g. from -15dB up to 25.5 dB). The time it takes for the recording level to return to its target value therefore depends on both the decay time and on the gain adjustment required. If the gain adjustment is small, it will be shorter than the decay time. The decay time can be programmed in power-of-two (2^n) steps, from 33.6ms, 67.2ms, 134.4ms etc. to 34.41s.

Attack time (Gain Ramp-Down) is the time that it takes for the PGA gain to ramp down across 90% of its range (e.g. from 25.5dB down to -15dB gain). The time it takes for the recording level to return to its target value therefore depends on both the attack time and on the gain adjustment required. If the gain adjustment is small, it will be shorter than the attack time. The attack time can be programmed in power-of-two (2^n) steps, from 8.4ms, 16.8ms, 33.6ms etc. to 8.6s.

When operating in stereo, the peak detector takes the maximum of left and right channel peak values, and any new gain setting is applied to both left and right PGAs, so that the stereo image is preserved. However, the ALC function can also be enabled on one channel only. In this case, only one PGA is controlled by the ALC mechanism, while the other channel runs independently with its PGA gain set through the control register.

When one ADC channel is unused or used for dc measurement, the peak detector disregards that channel. The ALC function can operate in digital mono mix mode (MONOMIX = 10), but not in analogue mono mix mode (MONOMIX = 01).

REGISTER ADDRESS	BIT	LABEL	DEFAULT	DESCRIPTION
R12 (0Ch) ALC Control 1	8:7	ALCSEL[1:0]	00	ALC function select 00 = ALC off (PGA gain set by register) 01 = Right channel only 10 = Left channel only 11 = Stereo (PGA registers unused)
	6:4	MAXGAIN	111	Set maximum gain for the PGA 111 : +30dB 110 : +24dB(-6dB steps) 001 : -6dB 000 : -12dB
	3:0	ALCL[3:0]	1100	ALC target level – sets signal level after PGA at ADC input in 1dB steps 0000: -18dB FS 0001: -17dB FS ... 1110: -4dB FS 1111: -3dB FS
R13 (0Dh) ALC Control 2	3:0	HLD[3:0]	0000	ALC hold time before gain is increased 0000: 0ms 0001: 2.67ms 0010: 5.33ms ... (time doubles with every step) 1111: 43.691s
	4	ALCZCE	0	Enable zero-cross function for the ALC gain updates 0: Zero-cross disabled 1: Zero-cross enabled
R14 (0Eh) ALC Control 3	3:0	ATK[3:0]	0010	ALC attack (gain ramp-down) time 0000: 8.4ms 0001: 16.8ms 0010: 33.6ms ... (time doubles with every step) 1010 or higher = 8.6s
	7:4	DCY[3:0]	0011	ALC decay (gain ramp-up) time 0000: 33.6ms 0001: 67.2ms 0010: 134.4ms ... (time doubles with every step) 1010 or higher = 34.41s

Table 12 ALC Control

PEAK LIMITER

To prevent clipping when a large signal occurs just after a period of quiet, the ALC circuit includes a limiter function. If the ADC input signal exceeds 87.5% of full scale (-1.16dBFS), the PGA gain is ramped down at the maximum attack rate (as when ATK = 0000), until the signal level falls below 87.5% of full scale. This function is automatically enabled whenever the ALC is enabled.

(Note: If ATK = 0000, then the limiter makes no difference to the operation of the ALC. It is designed to prevent clipping when long attack times are used.)

NOISE GATE

When the signal is very quiet and consists mainly of noise, the ALC function may cause “noise pumping”, i.e. loud hissing noise during silence periods. The WM8737L has a noise gate function that prevents noise pumping by comparing the signal level at the LINPUT1/2/3 and/or RINPUT1/2/3 pins against a noise gate threshold, NGTH. The noise gate cuts in when:

- Signal level at ADC [dB] < NGTH [dB] + PGA gain [dB] + Mic preamp gain [dB]

This is equivalent to:

- Signal level at input pin [dB] < NGTH [dB]

When the noise gate is triggered, the PGA gain is held constant (preventing it from ramping up as it would normally when the signal is quiet).

The table below summarises the noise gate control register. The NGTH control bits set the noise gate threshold with respect to the ADC full-scale range. The threshold is adjusted in 6dB steps. Levels at the extremes of the range may cause inappropriate operation, so care should be taken with set-up of the function. Note that the noise gate only works in conjunction with the ALC function, and always operates on the same channel(s) as the ALC (left, right, both, or none).

REGISTER ADDRESS	BIT	LABEL	DEFAULT	DESCRIPTION
R11 (0Bh) Noise Gate Control	0	NGAT	0	Noise gate function enable 1 = enable 0 = disable
	4:2	NGTH[2:0]	000	Noise gate threshold (with respect to ADC output level) 000: -78dBFS 001: -72dBfs ... 6 dB steps 110: -42dBFS 111: -30dBFS

Table 13 Noise Gate Control

DIGITAL AUDIO INTERFACE

The digital audio interface uses three pins:

- ADCDAT: ADC data output
- ADCLRC: ADC data alignment clock
- BCLK: Bit clock, for synchronisation

The digital audio interface takes the data from the internal ADC digital filters and places it on ADCDAT and ADCLRC. ADCDAT is the formatted digital audio data stream output from the ADC digital filters with left and right channels multiplexed together. ADCLRC is an alignment clock that indicates whether Left or Right channel data is present on the ADCDAT line. ADCDAT and ADCLRC are synchronous with the BCLK signal with each data bit transition signified by a BCLK high to low transition. ADCDAT is always an output. BCLK and ADCLRC may be inputs or outputs depending whether the device is in master or slave mode (see Master and Slave Mode Operation, below).

Four different audio data formats are supported:

- Left justified
- Right justified
- I²S
- DSP mode

All four of these modes are MSB first. They are described in Audio Data Formats, below. Refer to the Electrical Characteristic section for timing information.

MASTER AND SLAVE MODE OPERATION

The WM8737L can be configured as either a master or slave mode device. As a master device the WM8737L generates BCLK and ADCLRC and thus controls sequencing of the data transfer on ADCDAT. In slave mode, the WM8737L responds with data to clocks it receives over the digital audio interface. The mode can be selected by writing to the MS bit (see Table 14). Master and slave modes are illustrated below.

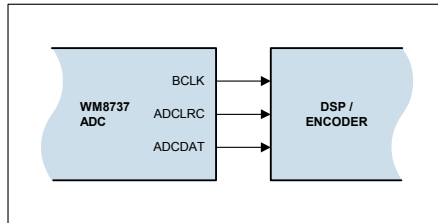

Figure 9a Master Mode

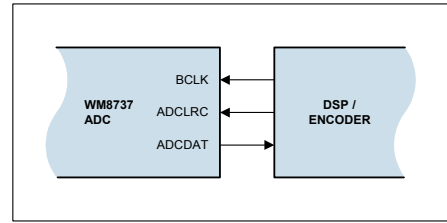

Figure 9b Slave Mode

AUDIO DATA FORMATS

In Left Justified mode, the MSB is available on the first rising edge of BCLK following an ADCLRC transition. The other bits up to the LSB are then transmitted in order. Depending on word length, BCLK frequency and sample rate, there may be unused BCLK cycles before each ADCLRC transition.

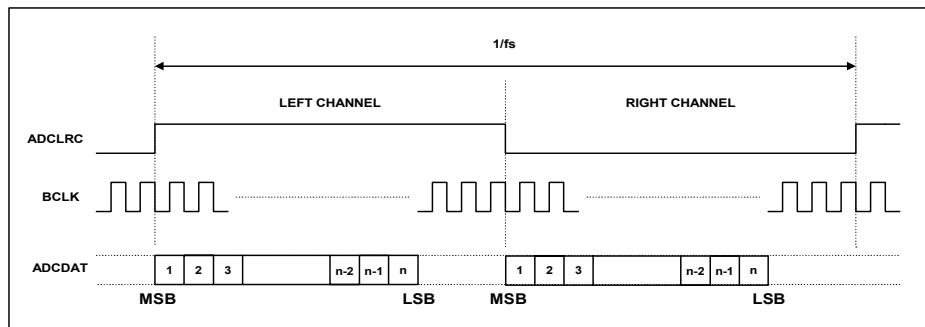

Figure 10 Left Justified Audio Interface (assuming n-bit word length)

In Right Justified mode, the LSB is available on the last rising edge of BCLK before an ADCLRC transition. All other bits are transmitted before (MSB first). Depending on word length, BCLK frequency and sample rate, there may be unused BCLK cycles after each ADCLRC transition.

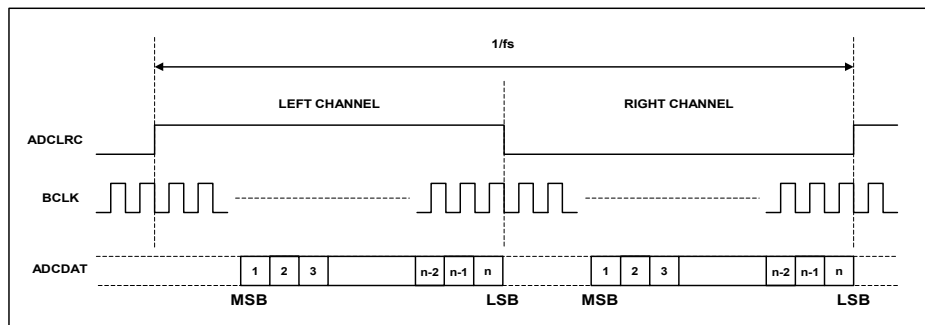

Figure 11 Right Justified Audio Interface (assuming n-bit word length)

In I²S mode, the MSB is available on the second rising edge of BCLK following an ADCLRC transition. The other bits up to the LSB are then transmitted in order. Depending on word length, BCLK frequency and sample rate, there may be unused BCLK cycles between the LSB of one sample and the MSB of the next.

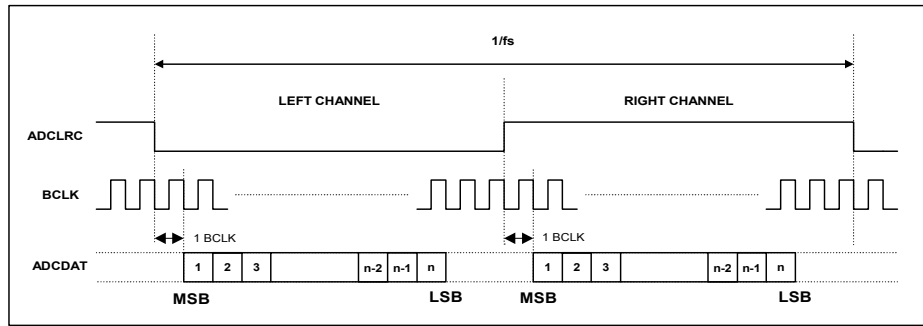

Figure 12 I²S Justified Audio Interface (assuming n-bit word length)

In DSP mode, the left channel MSB is available on either the 1st or 2nd rising edge of BCLK (selectable by LRP) following a rising edge of ADCLRC. Right channel data immediately follows left channel data. Depending on word length, BCLK frequency and sample rate, there may be unused BCLK cycles between the LSB of the right channel data and the next sample.

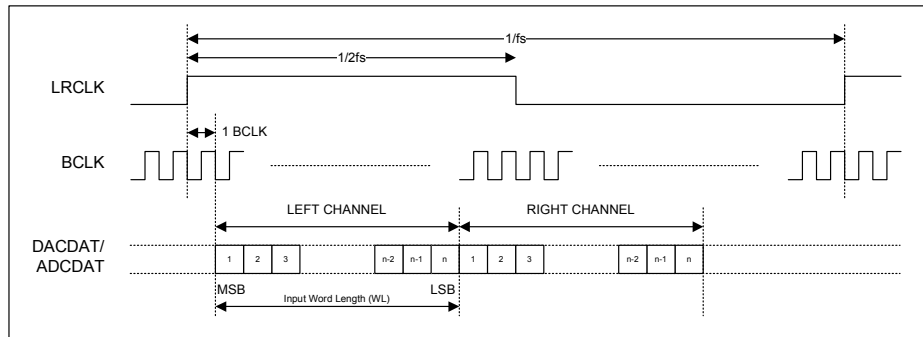

Figure 13 DSP Mode A Master Mode

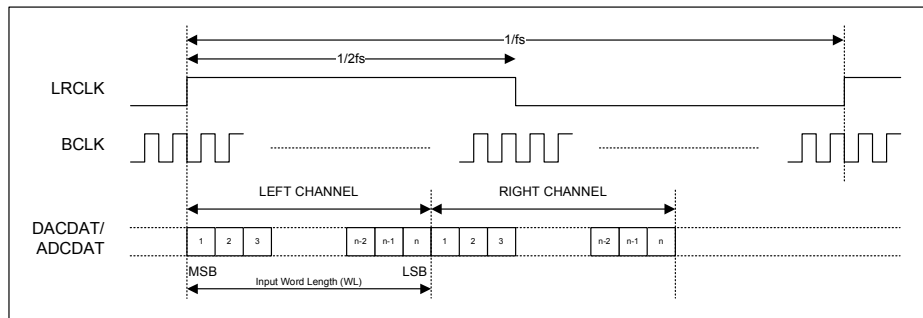

Figure 14 DSP Mode B, Master Mode Audio Interface

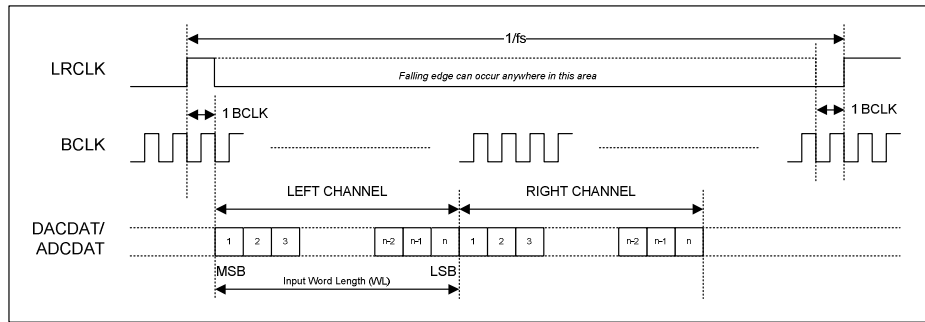

Figure 15 DSP Mode A Slave Mode

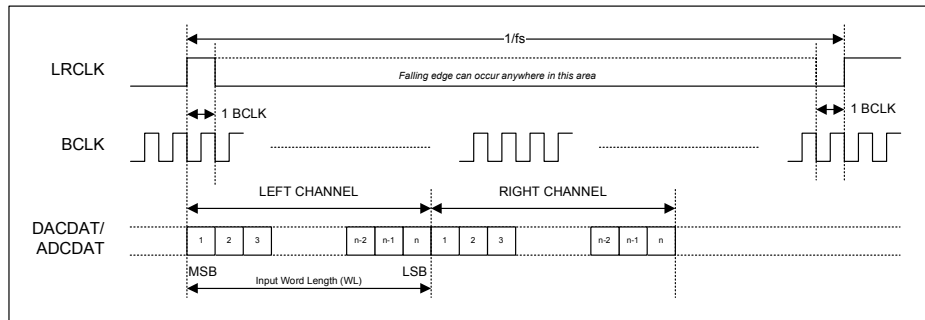

Figure 16 DSP Mode B Slave Mode

AUDIO INTERFACE CONTROL

The register bits controlling audio format, word length and master/slave mode are summarised below. Note that dynamically changing the software format may cause erroneous operation of the interfaces and is therefore not recommended.

All ADC data is signed 2's complement. The length of the digital audio data is programmable at 16/20/24 or 32 bits, as shown below. The ADC digital filters process data using 24 bits. If the WM8737L is programmed to output 16 or 20 bit data then it strips the LSBs from the 24 bit data. If the device is programmed to output 32 bits then it packs the LSBs with zeros.

REGISTER ADDRESS	BIT	LABEL	DEFAULT	DESCRIPTION
R7 (07h) Digital Audio Interface Format	1:0	FORMAT	10	Audio Data Format Select 11: DSP Mode 10: I ² S Format 01: Left justified 00: Right justified
	3:2	WL	10	Audio Data Word Length 11: 32 bits (see Note) 10: 24 bits 01: 20 bits 00: 16 bits

REGISTER ADDRESS	BIT	LABEL	DEFAULT	DESCRIPTION
	4	LRP	0	Right, left & I2S modes – ADCLRC polarity 1 = invert ADCLRC polarity 0 = normal ADCLRC polarity DSP Mode – mode A/B select 1 = MSB is available on 1st BCLK rising edge after ADCLRC rising edge (mode B) 0 = MSB is available on 2nd BCLK rising edge after ADCLRC rising edge (mode A)
	6	MS	0	Master / Slave Mode Control 1: Master Mode 0: Slave Mode
	7	SDODIS	0	ADCDAT serial data pin disable 0: ADCDAT pin enabled 1: ADCDAT pin off (high impedance)

Table 14 Audio Data Format Control

Note: Right Justified mode does not support 32-bit data. If WL=11 in Right justified mode, the actual word length is 24 bits.

To prevent any communication problems on the Audio Interface, the interface is disabled (ADCDAT tristated and floating) when the WM8737L starts up. Once the Audio Interface and sample rates have been programmed, the audio interface can be activated under software control by setting the AI bit (see “Power Management” section).

MASTER CLOCK AND AUDIO SAMPLE RATES

The master clock (MCLK) is used to operate the digital filters and the noise shaping circuits. The WM8737L supports a wide range of master clock frequencies, and can generate many commonly used audio sample rates directly from the master clock.

There are two clocking modes:

- ‘Normal’ mode supports master clocks of 128f_s, 192f_s, 256f_s, 384f_s, and their multiples
- USB mode supports 12MHz or 24MHz master clocks. This mode is intended for use in systems with a USB interface, and eliminates the need for an external PLL to generate another clock frequency for the audio ADC.

REGISTER ADDRESS	BIT	LABEL	DEFAULT	DESCRIPTION
R8 (08h) Clocking and Sample Rate Control	6	CLKDIV2	0	Master Clock Divide by 2 1: MCLK is divided by 2 0: MCLK is not divided
	0	USB	0	Clocking Mode Select 1: USB Mode 0: ‘Normal’ Mode
	5:1	SR[4:0]	0000	Sample Rate Control
	7	AUTO DETECT	0	Clock Ratio Autodetect (Slave Mode Only) 0: Autodetect Off 1: Autodetect On

Table 15 Clocking and Sample Rate Control

The clocking of the WM8737L is controlled using the CLKDIV2, USB, and SR control bits. Setting the CLKDIV2 bit divides MCLK by two internally. The USB bit selects between ‘Normal’ and USB mode. Each combination of the SR4 to SR0 control bits selects one sample rate (see next page). The digital filter characteristics are automatically adjusted to suit the MCLK and sample rate selected (see Digital Filter Characteristics).

Since all sample rates are generated by dividing MCLK, their accuracy depends on the accuracy of MCLK. If MCLK changes, the sample rates change proportionately. Note that some sample rates (e.g. 44.1kHz in USB mode) are approximated, i.e. they differ from their target value by a very small amount. This is not audible, as the maximum deviation is only 0.27% (8.0214kHz instead of 8kHz in USB mode - for comparison, a half-tone step corresponds to a 5.9% change in pitch).

In slave mode, it is possible to autodetect the audio clock rate ratio, instead of programming it. The WM8737L can autodetect the following clock ratios:

- CLKDIV2 = 0: MCLK = 128f_s, 192f_s, 256f_s, or 384f_s subject to MCLK < 40MHz
- CLKDIV2 = 1: MCLK = 256f_s, 384f_s, 512f_s, 768f_s, 1024f_s, 1536f_s, subject to MCLK < 40MHz

MCLK CLKDIV2=0	MCLK CLKDIV2=1	ADC SAMPLE RATE	USB	SR [4:0]	FILTER TYPE
Normal Clock Mode					
12.288MHz	24.576MHz	8 kHz (MCLK/1536)	0	00100	A
		12 kHz (MCLK/1024)	0	01000	A
		16 kHz (MCLK/768)	0	01010	A
		24 kHz (MCLK/512)	0	11100	A
		32 kHz (MCLK/384)	0	01100	A
		48 kHz (MCLK/256)	0	00000	A
		96 kHz (MCLK/128)	0	01110	B
11.2896MHz	22.5792MHz	8.0182 kHz (MCLK/1408)	0	10100	A
		11.025 kHz (MCLK/1024)	0	11000	A
		22.05 kHz (MCLK/512)	0	11010	A
		44.1 kHz (MCLK/256)	0	10000	A
		88.2 kHz (MCLK/128)	0	11110	B
18.432MHz	36.864MHz	8 kHz (MCLK/2304)	0	00101	A
		12 kHz (MCLK/1536)	0	01001	A
		16 kHz (MCLK/1152)	0	01011	A
		24 kHz (MCLK/768)	0	11101	A
		32 kHz (MCLK/576)	0	01101	A
		48 kHz (MCLK/384)	0	00001	A
		96 kHz (MCLK/192)	0	01111	B
16.9344MHz	33.8688MHz	8.0182 kHz (MCLK/2112)	0	10101	A
		11.025 kHz (MCLK/1536)	0	11001	A
		22.05 kHz (MCLK/768)	0	11011	A
		44.1 kHz (MCLK/384)	0	10001	A
		88.2 kHz (MCLK/192)	0	11111	B
USB Mode					
12.000MHz	24.000MHz	8 kHz (MCLK/1500)	1	00100	C
		11.0259 kHz (MCLK/1088)	1	11001	A
		12 kHz (MCLK/1000)	1	01000	C
		16 kHz (MCLK/750)	1	01010	C
		22.0588 kHz (MCLK/544)	1	11011	A
		24 kHz (MCLK/500)	1	11100	C
		32 kHz (MCLK/375)	1	01100	C
		44.118 kHz (MCLK/272)	1	10001	A
		48 kHz (MCLK/250)	1	00000	C
		88.235 kHz (MCLK/136)	1	11111	B
		96 kHz (MCLK/125)	1	01110	D

Table 16 Master Clock and Sample Rates

CONTROL INTERFACE

SELECTION OF CONTROL MODE

The WM8737L is controlled by writing to registers through a serial control interface. A control word consists of 16 bits. The first 7 bits (B15 to B9) are address bits that select which control register is accessed. The remaining 9 bits (B8 to B0) are register bits, corresponding to the 9 bits in each control register. The control interface can operate as either a 3-wire or 2-wire MPU interface. The MODE pin selects the interface format.

MODE	INTERFACE FORMAT
Low	2 wire
High	3 wire

Table 17 Control Interface Mode Selection

3-WIRE SERIAL CONTROL MODE

In 3-wire mode, every rising edge of SCLK clocks in one data bit from the SDIN pin. A rising edge on CSB latches in a complete control word consisting of the last 16 bits.

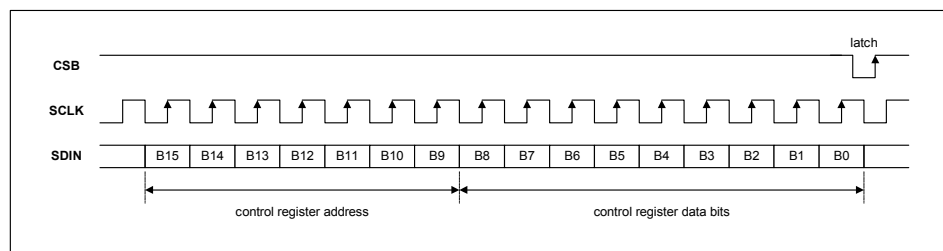

Figure 17 3-Wire Serial Control Interface

2-WIRE SERIAL CONTROL MODE

The WM8737L supports software control via a 2-wire serial bus. Many devices can be controlled by the same bus, and each device can be identified by one of two 7-bit address (this is not the same as the 7-bit address of each register in the WM8737L).

The WM8737L interface can be written to only and cannot be read back. The controller indicates the start of data transfer with a high to low transition on SDIN while SCLK remains high. This indicates that a device address and data will follow. All devices on the 2-wire bus respond to the start condition and shift in the next eight bits on SDIN (7-bit address + Read/Write bit, MSB first). If the device address received matches the address of the WM8737L and the R/W bit is '0', indicating a write, then the WM8737L responds by pulling SDIN low on the next clock pulse (ACK). If the address is not recognised or the R/W bit is '1', the WM8737L returns to the idle condition and wait for a new start condition and valid address.

Once the WM8737L has acknowledged a correct address, the controller sends the first byte of control data (B15 to B8, i.e. the WM8737L register address plus the first bit of register data). The WM8737L then acknowledges the first data byte by pulling SDIN low for one clock pulse. The controller then sends the second byte of control data (B7 to B0, i.e. the remaining 8 bits of register data), and the WM8737L acknowledges again by pulling SDIN low.

The transfer of data is complete when there is a low to high transition on SDIN while SCLK is high. After receiving a complete address and data sequence the WM8737L returns to the idle state and waits for another start condition. If a start or stop condition is detected out of sequence at any point during data transfer (i.e. SDIN changes while SCLK is high), the device jumps to the idle condition.

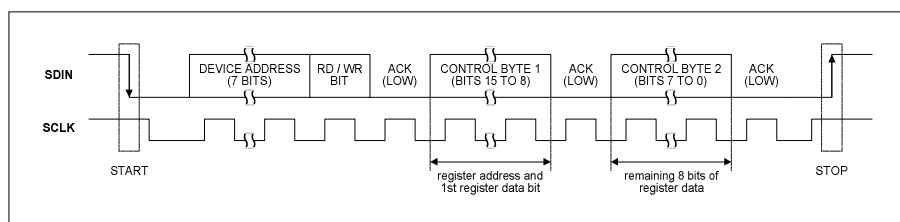

Figure 18 2-Wire Serial Control Interface

The WM8737L has two possible device addresses, which can be selected using the CSB pin.

CSB STATE	DEVICE ADDRESS
Low or Unconnected	0011010
High	0011011

Table 18 2-Wire MPU Interface Address Selection

POWER SUPPLIES

The WM8737L can use up to four separate power supplies:

- AVDD/AGND: Analogue supply, powers all analogue functions except the microphone pre-amp and MICBIAS. AVDD can range from 1.8V to 3.6V and has the most significant impact on overall power consumption. A large AVDD improves audio quality by increasing the maximum input signal range and thus SNR.
- MVDD: Supply pin for microphone pre-amp and MICBIAS only. This separate pin makes it possible to generate MICBIAS voltages larger than AVDD up to a maximum of 3.6V. If this is not necessary, MVDD should also be tied to AVDD.
- DCVDD: Digital core supply, powers all digital functions except the audio and control interface pins. DCVDD can range from 1.42V to 3.6V, and has no effect on audio quality. The return path for DCVDD is DGND, which is shared with DBVDD.
- DBVDD: Digital buffer supply, powers the audio and control interface pins. This makes it possible to run the digital core at very low voltages, saving power, while interfacing to other digital devices using a higher voltage. DBVDD draws much less power than DCVDD, and has no effect on audio quality. The return path for DBVDD is DGND, which is shared with DCVDD.

It is possible to use the same supply voltage on all three. However, digital and analogue supplies should be routed and decoupled separately to keep digital switching noise out of the analogue signal paths.

POWER MANAGEMENT

The WM8737L has a power management register that allows users to select which functions are active. For minimum power consumption, unused functions should be disabled. To avoid any pop or click noise.

When the WM8737L is not in use, it can be put into either one of two standby modes or OFF mode.

OFF mode is achieved by writing zeros to all bits in the power management register and gives lowest power consumption, but wake-up may take several seconds if the VMID decoupling capacitor has discharged, as it must be recharged from the selectable impedance VMID source.

The output impedance of VMID can be changed to allow variable voltage stabilization time after VMID is powered on. The 300kΩ setting will ensure minimum VMID power consumption but with slow charging time, while the 2.5kΩ setting will allow a more rapid charging time but with the penalty of greatly increased VMID power consumption. The default 75kΩ setting is recommended for most applications.

REGISTER ADDRESS	BIT	LABEL	DEFAULT	DESCRIPTION
R10 (0Ah) VMID Impedance Control	3:2	VMIDSEL	00	VMID impedance selection control 00: 75kΩ output 01: 300kΩ output 10: 2.5kΩ output

Table 19 VMID Impedance Selection

Standby mode 1 is achieved by powering down everything except the VMID source and gives a very low power sleep mode. Wake-up may require a few milliseconds to ensure that the VREF voltage has stabilized.

Standby mode 2 is achieved by not powering down VMID and VREF. The WM8737L can awaken instantly from standby mode 2 because VREF is already stable.

REGISTER ADDRESS	BIT	LABEL	DEFAULT	DESCRIPTION
R6 (06h) Power Management	8	VMID	0	VMID (necessary for all other functions)
	7	VREF	0	VREF (necessary for all other functions)
	6	AI	0	Audio Interface
	5	PGL	0	PGA Left
	4	PGR	0	PGA Right
	3	ADL	0	ADC Left
	2	ADR	0	ADC Right
	1:0	MICBIAS	00	see "Microphone Bias" section
R2 (02h)	4	LMBE	0	Mic Boost Left (see "Input Signal Path")
R3 (03h)	4	RMBE	0	Mic Boost Right (see "Input Signal Path")

Notes: All control bits are 0=OFF, 1=ON

Table 20 Power Management

REGISTER MAP

REGISTER	ADDRESS (BIT 15 – 9)	REMARKS	BIT8	BIT7	BIT6	BIT5	BIT4	BIT3	BIT2	BIT1	BIT0
R0 (00h)	0000000	Left PGA	LVU	LINVOL [7:0]							
R1 (01h)	0000001	Right PGA	RVU	RINVOL [7:0]							
R2 (02h)	0000010	Audio Path L	LINSEL		LMICBOOST		LMBE	LMZC	LPZC	LZCTO[1:0]	
R3 (03h)	0000011	Audio Path R	RINSEL		RMICBOOST		RMBE	RMZC	RPZC	RZCTO[1:0]	
R4 (04h)	0000100	3D Enhance	0	DIV2	3DLC	3DUC	3DDEPTH			3DE	
R5 (05h)	0000101	ADC Control	MONOMIX		POLARITY		HPOR	0	LP	MONOUT	ADC HPD
R6 (06h)	0000110	Power Mgmt	VMID	VREF	AI	PGL	PGR	ADL	ADR	MICBIAS	
R7 (07h)	0000111	Audio Format	0	SDODIS	MS	0	LRP	WL		FORMAT	
R8 (08h)	0001000	Clocking	0	AUTO DETECT	CLK DIV2	SR (Sample Rate Selection)				USB Mode	
R9 (09h)	0001001	Mic Preamp Control	0	0	0	0	0	RBYPEN	LBYPEN	MBCTRL[1:0]	
R10 (0Ah)	0001010	Misc. biases control	0	0	0	0	0	VMIDSEL [1:0]		LINPUT1 dc BIAS ENABLE	RINPUT1 dc BIAS ENABLE
R11 (0Bh)	0001011	Noise Gate	0	0	0	0	NGTH (Threshold)			0	NGAT
R12 (0Ch)	0001100	ALC1	ALCSEL		MAXGAIN			ALCL (Target Level)			
R13 (0Dh)	0001101	ALC2	Reserved (must write zeros)			0	ALCZCE	HLD (Hold Time)			
R14 (0Eh)	0001110	ALC3	0	DCY (Decay Time)			ATK (Attack Time)				
R15 (0Fh)	0001111	Reset	RESET (writing 00000000 to this register resets all registers to their default state)								

Table 21 Control Register Map

DIGITAL FILTER CHARACTERISTICS

The WM8737L has four different types of digital filter characteristics to suit different MCLK and sample rates (see Master Clock and Audio Sample Rates).

PARAMETER	TEST CONDITIONS	MIN	TYP	MAX	UNIT
ADC Filter Type A					
Passband	+/- 0.05dB	0		0.4535fs	
	-6dB		0.5fs		
Passband Ripple				+/- 0.05	dB
Stopband		0.5465fs			
Stopband Attenuation	f > 0.5465fs	-60			dB
High Pass Filter Corner Frequency	-3dB		3.7		Hz
	-0.5dB		10.4		
	-0.1dB		21.6		

Table 22 Digital Filter Characteristics

TERMINOLOGY

1. Stop Band Attenuation (dB) - the degree to which the frequency spectrum is attenuated (outside audio band)
2. Pass-band Ripple – any variation of the frequency response in the pass-band region
3. The filter responses are shown on the following page.

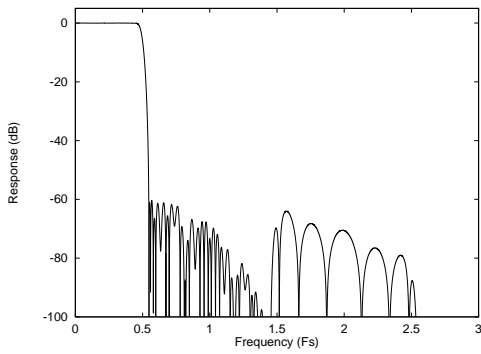

Figure 19 Digital Filter Type A Frequency Response

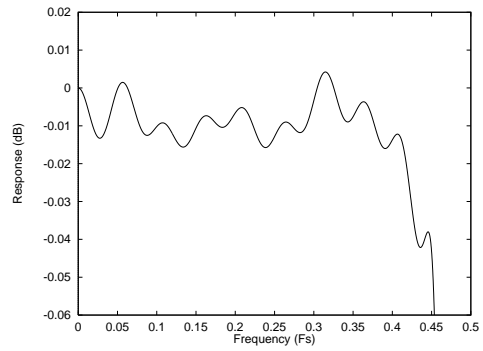

Figure 20 ADC Digital Filter Type A Ripple

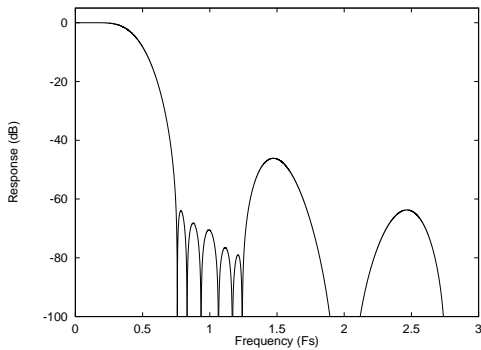

Figure 21 Digital Filter Type B Frequency Response

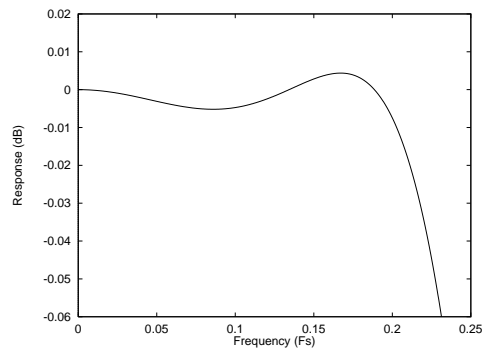

Figure 22 Digital Filter Type B Ripple

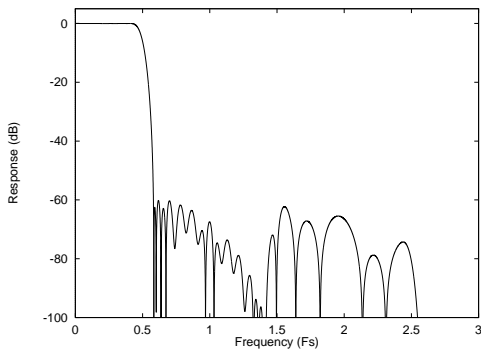

Figure 23 Digital Filter Type C Frequency Response

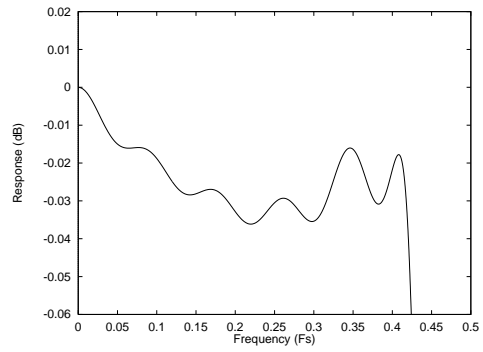

Figure 24 Digital Filter Type C Ripple

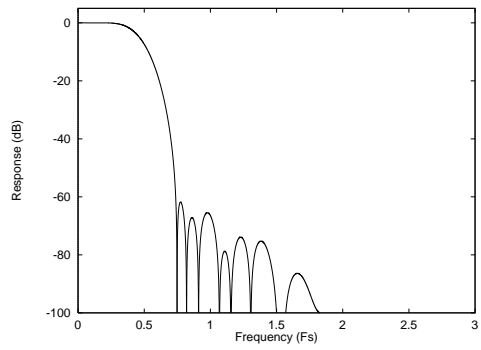

Figure 25 Digital Filter Type D Frequency Response

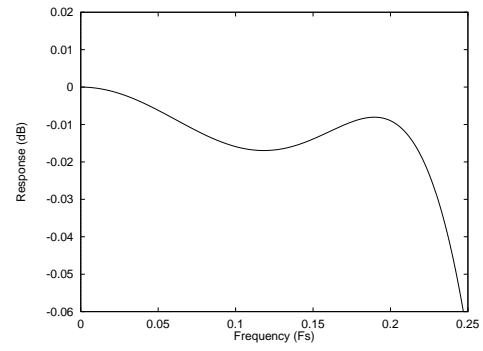

Figure 26 Digital Filter Type D Ripple

APPLICATIONS INFORMATION

LINE INPUT CONFIGURATION

In order to avoid clipping, the user must ensure that the input signal does not exceed AVDD. This may require a potential divider circuit in some applications. It is also recommended to remove RF interference picked up on any cables using a simple first-order RC filter, as high-frequency components in the input signal may otherwise cause aliasing distortion in the audio band. This filter must not have high output impedance at audio frequencies (e.g. use a LC filter) if PGA gain errors are to be minimised when bypassing the microphone preamplifier.

When using ac signals with no dc bias they should be coupled to the WM8737L signal inputs through a DC blocking capacitor, e.g. 470nF or 1 μ F when using the microphone preamplifier, and at least 10 μ F if directly driving the PGA (bigger capacitance may be required at higher gains due to the low PGA input impedance at high gain).

MICROPHONE INPUT CONFIGURATION

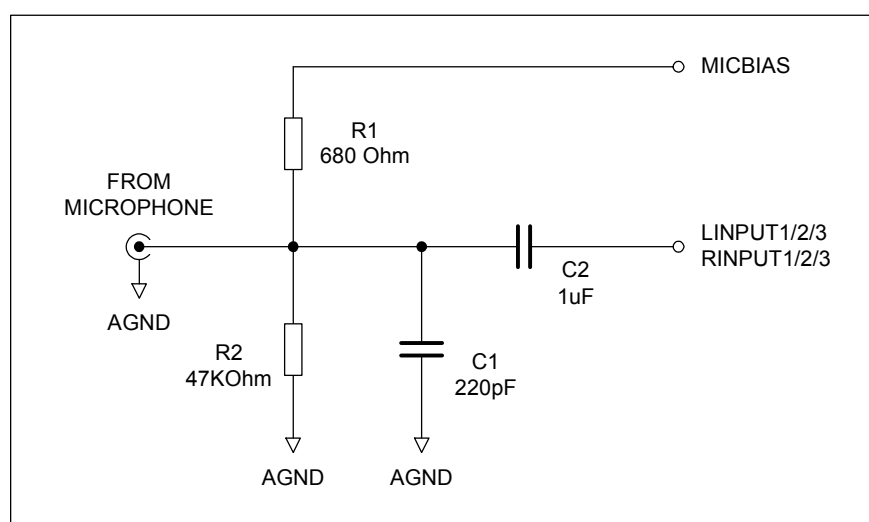

Figure 27 Recommended Circuit for Microphone Input

For interfacing to a microphone, the ALC function should be enabled and the microphone boost switched on. Microphones held close to a speaker's mouth would normally use a lower boost setting such as 13dB, while tabletop or room microphones would need a higher boost, for example 28dB.

The recommended application circuit is shown above. R1 and R2 form part of the biasing network (refer to Microphone Bias section). R1 connected to MICBIAS is necessary only for electret type microphones that require a voltage bias. R2 should always be present to prevent the microphone input from charging to a high voltage which may damage the microphone on connection. R1 and R2 should be large so as not to attenuate the signal from the microphone, which can have source impedance greater than 2k Ω . C1 together with the source impedance of the microphone and the WM8737L input impedance forms an RF filter. C2 is a dc blocking capacitor to allow the microphone to be biased at a different dc voltage to the MICIN signal.

RECOMMENDED EXTERNAL COMPONENTS

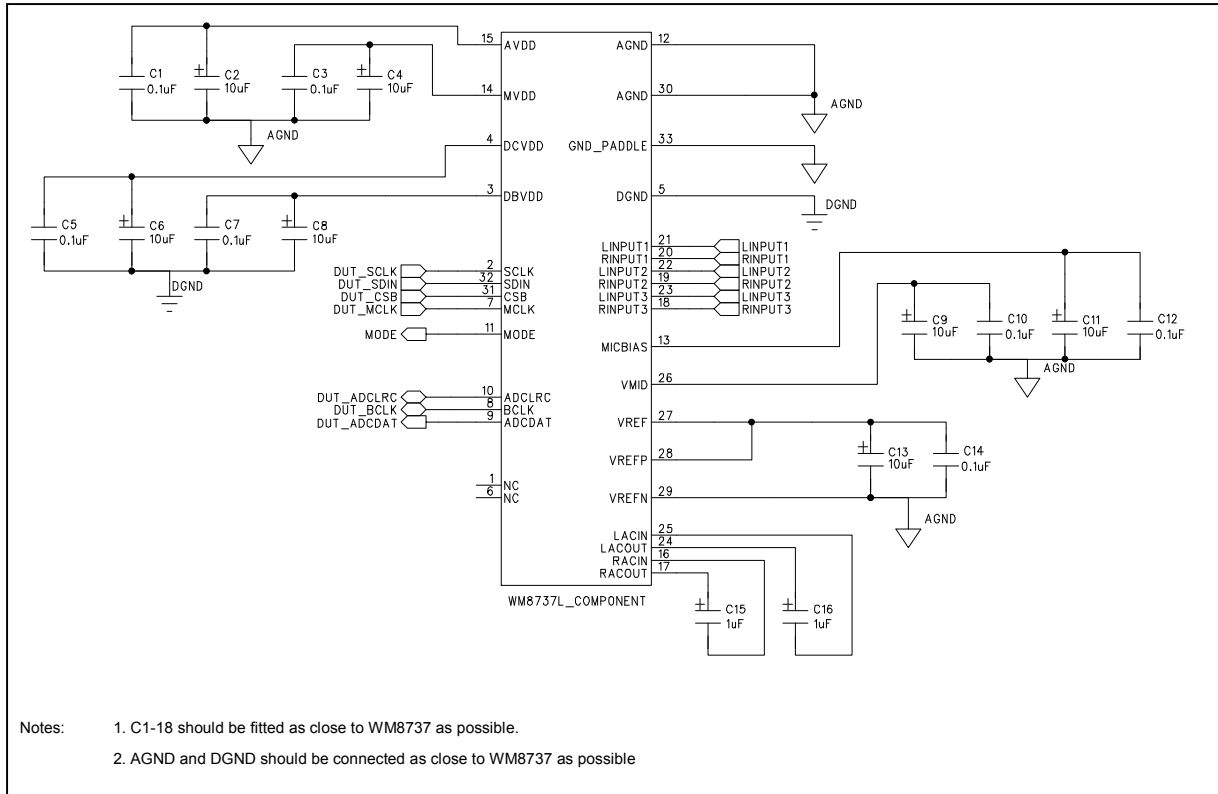
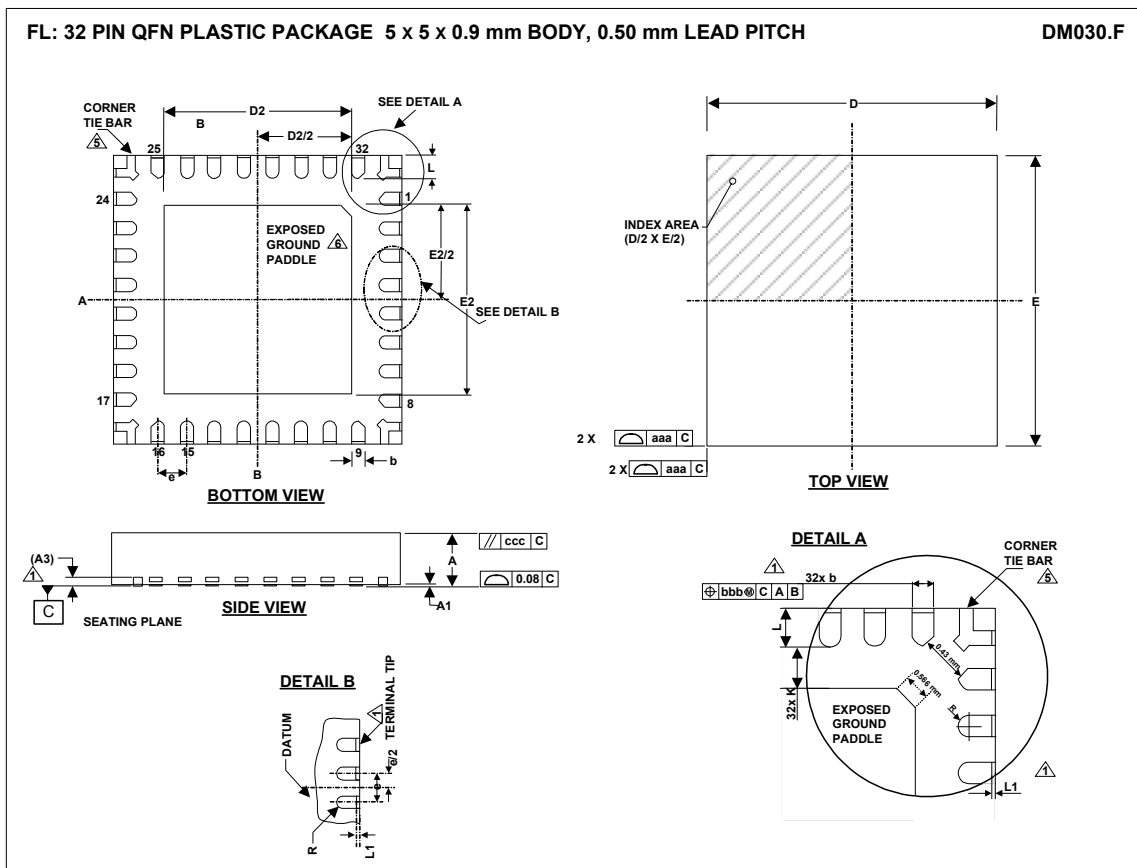

Figure 28 External Components Diagram

COMPONENT REFERENCE	SUGGESTED VALUE	DESCRIPTION
C1	100nF	Decoupling for AVDD
C2	10µF	Reservoir capacitor for AVDD
C3	100nF	Decoupling for MVDD
C4	10µF	Reservoir capacitor for MVDD
C5	100nF	Decoupling for DCVDD
C6	10µF	Reservoir capacitor for DCVDD
C7	100nF	Decoupling for DBVDD
C8	10µF	Reservoir capacitor for DBVDD
C9	100nF	Decoupling for VMID
C10	10µF	Reservoir capacitor for VMID
C11	100nF	Decoupling for MICBIAS
C12	10µF	Reservoir capacitor for MICBIAS
C9	100nF	Decoupling for VREF
C10	10µF	Reservoir capacitor for VREF
C11	1µF	RACIN to RACOUT coupling capacitor
C12	1µF	LACIN to LACOUT coupling capacitor

Table 23 External Components Descriptions

PACKAGE DIMENSIONS



Symbols	Dimensions (mm)			NOTE
	MIN	NOM	MAX	
A	0.85	0.90	1.00	
A1	0	0.02	0.05	
A3		0.2 REF		
b	0.18	0.23	0.30	1
D		5.00 BSC		
D2	3.2	3.3	3.4	2
E		5.00 BSC		
E2	3.2	3.3	3.4	2
e		0.5 BSC		
L	0.35	0.4	0.45	
L1			0.1	1
R	b(min)/2			
K	0.20			
Tolerances of Form and Position				
aaa		0.15		
bbb		0.10		
ccc		0.10		
REF:	JEDEC, MO-220, VARIATION VHHD-2			

- NOTES:
- DIMENSION b APPLIED TO METALLIZED TERMINAL AND IS MEASURED BETWEEN 0.25 mm AND 0.30 mm FROM TERMINAL TIP. DIMENSION L1 REPRESENTS TERMINAL PULL BACK FROM PACKAGE SIDE WALL. MAXIMUM OF 0.1mm IS ACCEPTABLE. WHERE TERMINAL PULL BACK EXISTS, ONLY UPPER HALF OF LEAD IS VISIBLE ON PACKAGE SIDE WALL DUE TO HALF ETCHING OF LEADFRAME.
 - FALLS WITHIN JEDEC, MO-220 WITH THE EXCEPTION OF D2, E2.
 - D2, E2: LARGER PAD SIZE CHOSEN WHICH IS JUST OUTSIDE JEDEC SPECIFICATION
 - ALL DIMENSIONS ARE IN MILLIMETRES
 - THIS DRAWING IS SUBJECT TO CHANGE WITHOUT NOTICE.
 - SHAPE AND SIZE OF CORNER TIE BAR MAY VARY WITH PACKAGE TERMINAL COUNT. CORNER TIE BAR IS CONNECTED TO EXPOSED PAD INTERNALLY.
 - REFER TO APPLICATION NOTE WAN_0118 FOR FURTHER INFORMATION REGARDING PCB FOOTPRINTS AND QFN PACKAGE SOLDERING.

IMPORTANT NOTICE

Wolfson Microelectronics plc ("Wolfson") products and services are sold subject to Wolfson's terms and conditions of sale, delivery and payment supplied at the time of order acknowledgement.

Wolfson warrants performance of its products to the specifications in effect at the date of shipment. Wolfson reserves the right to make changes to its products and specifications or to discontinue any product or service without notice. Customers should therefore obtain the latest version of relevant information from Wolfson to verify that the information is current.

Testing and other quality control techniques are utilised to the extent Wolfson deems necessary to support its warranty. Specific testing of all parameters of each device is not necessarily performed unless required by law or regulation.

In order to minimise risks associated with customer applications, the customer must use adequate design and operating safeguards to minimise inherent or procedural hazards. Wolfson is not liable for applications assistance or customer product design. The customer is solely responsible for its selection and use of Wolfson products. Wolfson is not liable for such selection or use nor for use of any circuitry other than circuitry entirely embodied in a Wolfson product.

Wolfson's products are not intended for use in life support systems, appliances, nuclear systems or systems where malfunction can reasonably be expected to result in personal injury, death or severe property or environmental damage. Any use of products by the customer for such purposes is at the customer's own risk.

Wolfson does not grant any licence (express or implied) under any patent right, copyright, mask work right or other intellectual property right of Wolfson covering or relating to any combination, machine, or process in which its products or services might be or are used. Any provision or publication of any third party's products or services does not constitute Wolfson's approval, licence, warranty or endorsement thereof. Any third party trade marks contained in this document belong to the respective third party owner.

Reproduction of information from Wolfson datasheets is permissible only if reproduction is without alteration and is accompanied by all associated copyright, proprietary and other notices (including this notice) and conditions. Wolfson is not liable for any unauthorised alteration of such information or for any reliance placed thereon.

Any representations made, warranties given, and/or liabilities accepted by any person which differ from those contained in this datasheet or in Wolfson's standard terms and conditions of sale, delivery and payment are made, given and/or accepted at that person's own risk. Wolfson is not liable for any such representations, warranties or liabilities or for any reliance placed thereon by any person.

ADDRESS:

Wolfson Microelectronics plc
26 Westfield Road
Edinburgh
EH11 2QB
United Kingdom

Tel :: +44 (0)131 272 7000

Fax :: +44 (0)131 272 7001

Email :: sales@wolfsonmicro.com