

### FEATURES

- 12-Bit binary and 3-digit BCD models
- 7 Output ranges
- 3 $\mu$ s Vout settling time
- 300ns Iout settling time
- Guaranteed monotonicity over full temperature range
- Integral nonlinearity  $\pm 1/2$ LSB (binary) and  $\pm 1/4$ LSB (BCD), maximum
- Differential nonlinearity  $\pm 3/4$ LSB (binary) and  $\pm 1/4$ LSB (BCD), maximum
- High-reliability QL versions available

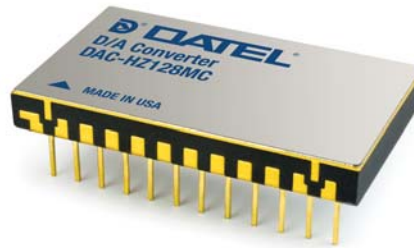

### PRODUCT OVERVIEW

The DAC-HZ Series are high-performance, monolithic, 12-bit binary and 3-digit BCD, digital-to-analog converters. The DAC-HZ Series are complete and self-contained with a precision internal reference and fast output operational amplifier. Pin programmable output voltage and current ranges are provided for a high degree of application flexibility; the binary versions offer 5 output voltage ranges and two current ranges while the BCD models offer 3 and 1 output ranges, respectively.

The DAC-HZ Series contains a precision embedded Zener reference circuit. This eliminates code-dependent ground currents by routing current from the positive supply to the internal ground node as determined by the R-2R ladder network. The internal feedback resistors for the on-board amplifier track the ladder network resistors, enhancing temperature performance. The excellent tracking of the resistors results in temperature coefficients for differential nonlinearity, zero and gain of  $\pm 2$ ,  $\pm 3$  and  $\pm 20$ ppm/ $^{\circ}$ C maximum, respectively.

#### INPUT/OUTPUT CONNECTIONS

PIN	FUNCTION	PIN	FUNCTION
1	BIT 1 (MSB)	24	REFERENCE OUT
2	BIT 2	23	GAIN ADJUST
3	BIT 3	22	+15V SUPPLY
4	BIT 4	21	GROUND
5	BIT 5	20	CURRENT OUTPUT
6	BIT 6	19	20V RANGE
7	BIT 7	18	10V RANGE
8	BIT 8	17	BIPOLAR OFFSET
9	BIT 9	16	REFERENCE IN
10	BIT 10	15	VOLTAGE OUTPUT
11	BIT 11	14	-15V SUPPLY
12	BIT 12 (LSB)	13	NO CONNECTION

### BLOCK DIAGRAM

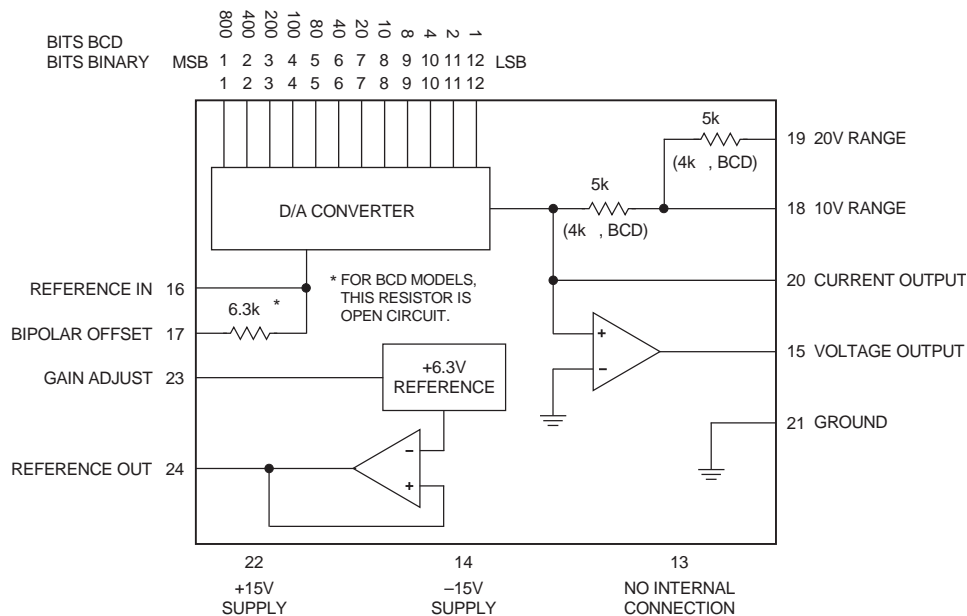

Figure 1. DAC-HZ Functional Block Diagram

### FUNCTIONAL SPECIFICATIONS

(Typical at +25°C and ±15V supplies unless otherwise noted.)

DESCRIPTION		
<b>INPUTS</b>	DAC-HZ12B (BINARY)	DAC-HZ12D (BCD)
Resolution	12 binary bits	3 BCD digits
Coding, Unipolar Output	Comp. binary	Comp. BCD
Coding, Bipolar Output	Comp. off. binary	—
Input Logic Level, Bit ON ("0")	0V to +0.8V at -1mA	
Input Logic Level, Bit OFF ("0")	+2.4V to +5.5V at +40μA	
Logic Loading	1 TTL load	
<b>PERFORMANCE</b> ①		
Voltage Output Nonlinearity	±1/2LSB max.	±1/4LSB max.
Differential Nonlinearity	±3/4LSB max	±1/4LSB max.
Gain Error, Before Trimming	±0.1% ②	*
Zero Error, Before Trimming	±0.1% of FSR ②	*
Gain Tempco, maximum	±20ppm/°C	*
Zero Tempco, Unipolar, max.	±3ppm/°C of FSR	*
Offset Tempco, Bipolar, max.	±10ppm/°C of FSR	*
Diff. Nonlinearity Tempco, max.	±2ppm/°C of FSR	*
Monotonicity	Over oper. temp. range	*
Settling Time, IOUT to ±1/2LSB ③	300ns	*
Settling Time, VOUT to ±1/2LSB	3μs ④	*
Slew Rate	±10V/μs	*
Power Supply Rejection	±0.006%FSR/%Sup.	*
<b>OUTPUTS</b>		
Output Current, Unipolar	0 to -2mA, ±20%	0 to -1.25mA, ±10%
Output Current, Bipolar	±1mA, ±20%	—
Compliance Voltage, IOUT	±2.5V	*
Output Impedance, IOUT, Unipolar	2kΩ	*
Output Impedance, IOUT, Bipolar	2kΩ	—
Output Voltage Ranges, Unipolar	0 to +5V	0 to +2.5V
	0 to +10V	0 to +5V
	—	0 to +10V
Output Voltage Ranges, Bipolar	±2.5V	—
	±5V	—
	±10V	—
Output Current, VOUT	±5mA min.	*
Output Impedance, VOUT	0.05Ω	*
<b>POWER REQUIREMENTS</b>		
Power Supply Voltages	+15V, ±0.5V at 16mA	
	-15V, ±0.5V at 20mA	
	±12V operation ⑤	
Power Dissipation, maximum	500mW	
<b>PHYSICAL/ENVIRONMENTAL</b>		
Operating Temperature Range, Case	0°C to +70°, -40°C to +85° and -55°C to +125°C	
Storage Temperature Range	-65°C to +150°C	
Package Type	24-pin DDIP	
Weight	0.22 ounces (6.3 grams)	

\* Specifications same as first column.

— No equivalent specifications

#### Footnotes:

- ① FSR is full-scale range and is 10V for 0 to +10V or -5V to +5V outputs, 20V for ±10V output, etc.
- ② Initial gain and offset errors are trimmable to zero. See Connection Diagrams.
- ③ Current output mode.
- ④ For 2.5kΩ or 5kΩ feedback. For 10kΩ feedback, the settling time is 4μs.
- ⑤ For ±12V operation of binary models, contact factory.

### ABSOLUTE MAXIMUM RATINGS

PARAMETERS	LIMITS	UNITS
Positive Supply, Pin 22	+18	Volts
Negative Supply, Pin 14	-18	Volts
Digital Input Voltage, Pins 1-12	+5.5	Volts
Output Current, Pin 15	±20	mA
Lead Temperature (soldering, 10s)	300	°C

### TECHNICAL NOTES

1. The DAC-HZ12 Series converters are designed and factory calibrated to give ±1/2LSB linearity (binary version) and ±1/4LSB linearity (BCD version) with respect to a straight line between end points. This means that if zero and full scale are exactly adjusted externally, the relative accuracy will be ±1/2LSB (±1/4LSB, BCD version) everywhere over the full output range without any additional adjustments.
2. These converters must be operated with local supply bypass capacitors from +15V to ground and -15V to ground. Tantalum type capacitors of 1μF are recommended and should be mounted as close as possible to the converter. If the converters are used in a high-frequency noise environment, a 0.01μF ceramic capacitor should be used across each tantalum capacitor.
3. When operating in the current output mode, the equivalent internal current source of 2mA (1.25mA, BCD) must drive both the internal source resistances and the external load resistor. A 300ns output settling time is achieved for the voltage across a 100Ω load resistor; for higher value resistors the settling time becomes longer due to the output capacitance of the converter. For fastest possible voltage output for a large transition, an external fast-settling amplifier such as DATEL's AM-500 should be used in the inverting mode. Settling time of less than 1μs can be achieved. See application diagram.

### CALIBRATION PROCEDURE

Select the desired output voltage range and connect the converter as shown in the Output Range Selection Table and the Connection Diagrams. Refer to the Coding Tables.

1. Select the desired output range and connect the converter as shown in the Output Range Selection tables and the connection diagrams.
2. To calibrate, refer to the coding tables. Note that complementary coding is used.
3. **Zero and Offset Adjustments.** For unipolar operation set all digital inputs to "1" (+2.0 to +5.5V) and adjust the ZERO ADJUST potentiometer for zero output voltage or current. For bipolar operation set all digital inputs to "1" and adjust the OFFSET ADJUST potentiometer for the negative full scale (for voltage out) or positive full scale (for current out) output value shown in the coding table.
4. **Gain Adjustment.** Set all digital inputs to "0" (0V to +0.8V) and adjust the GAIN ADJUST potentiometer for the positive full scale (for voltage out) or negative full scale (for current out) output value shown in the coding table.

**CONNECTION DIAGRAMS**

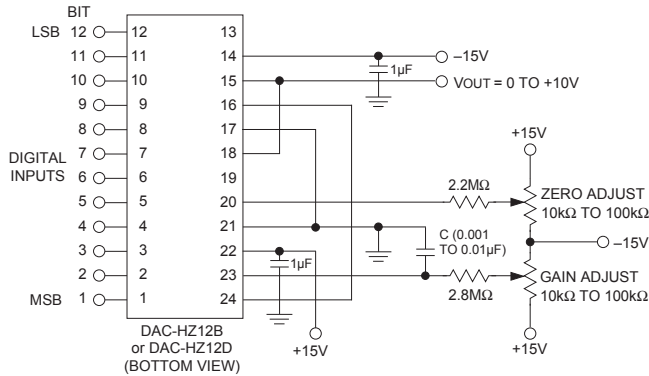

**Figure 2. Unipolar Voltage Output Connections**

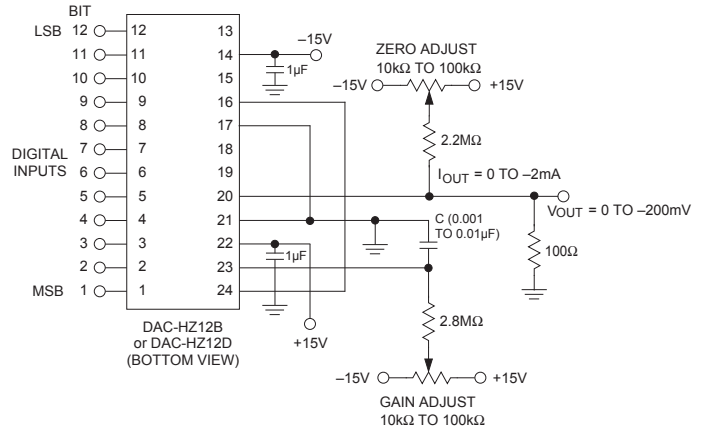

**Figure 3. Unipolar Current Output Connections**

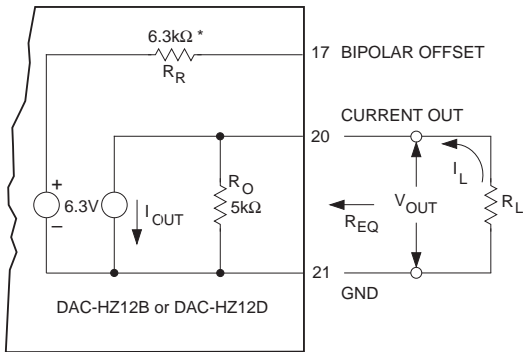

\*This resistor is open circuit for BCD models

$V_{OUT} = \pm 2.5V$  Maximum  
(Output compliance voltage)

$R_{EQ} = R_O = 5k\Omega$  for unipolar operation

$R_{EQ} = R_R \parallel R_O = 2.8k\Omega$  for bipolar operation

$I_{OUT} = 2mA$  binary  
 $= 1.25mA$  BCD

**Figure 4. Equivalent Current Mode Output Circuit**

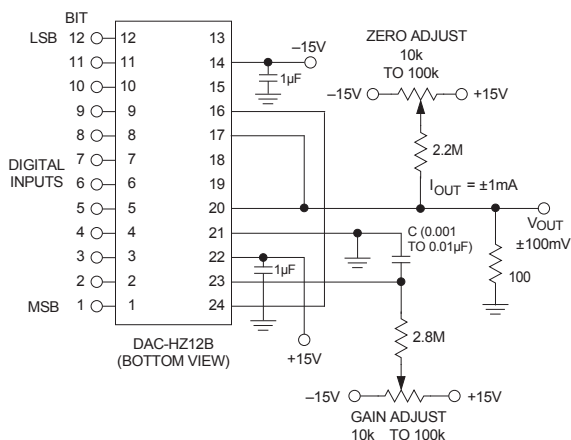

**Figure 6. Bipolar Current Output Connections**

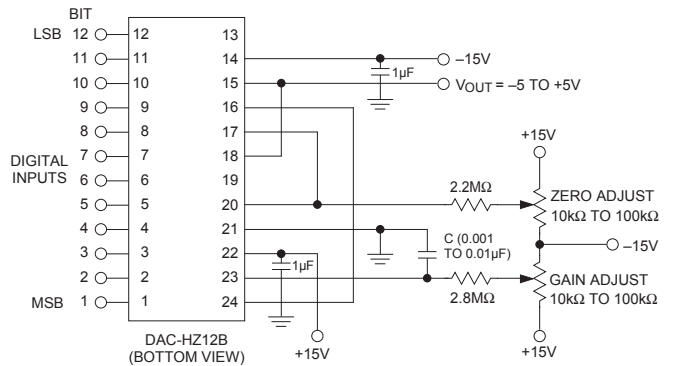

**Figure 5. Bipolar Voltage Output Connections**

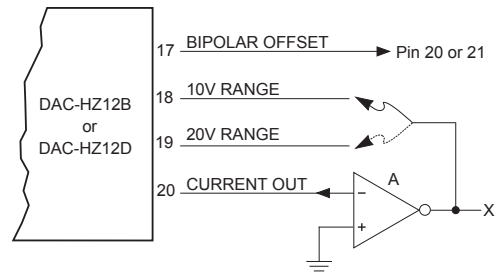

A = External high-speed inverting op amp; use DATEL's AM-500 for less than 1μsec output settling.

Refer to the output range selection tables, Tables 1 and 2. Wherever pin 15 appears, use pin X of the external amplifier and scale as desired.

**Figure 7. Using a High-Speed External Op Amp for Faster Settling**

### OUTPUT RANGE SELECTION TABLES

RANGE	CONNECT THESE PINS TOGETHER			
DAC-HZ12B Binary Output Range Selection				
±10V	15 & 19	17 & 20	—	16 & 24
±5V	15 & 18	17 & 20	—	16 & 24
±2.5V	15 & 18	17 & 20	19 & 20	16 & 24
+10V	15 & 18	17 & 21	—	16 & 24
+5V	15 & 18	17 & 21	19 & 20	16 & 24
±1mA	—	17 & 20	—	16 & 24
DAC-HZ12D BCD Output Range Selection				
+10V	15 & 19	17 & 21	—	16 & 24
+5V	15 & 18	17 & 21	—	16 & 24
+2.5V	15 & 18	17 & 21	19 & 20	16 & 24
-1.25mA	—	17 & 21	—	16 & 24

Voltage output is at pin 15; current output is at pin 20.

### OUTPUT CODING TABLES

UNIPOLAR OUTPUT, COMPLEMENTARY BINARY						
BINARY INPUT CODE			UNIPOLAR OUTPUT RANGES			
MSB		LSB	0 to +10V	0 to +5V	0 to -2mA	
0000	0000	0000	+9.9976V	+4.9988V	-1.9995	
0011	1111	1111	+7.5000	+3.7500	-1.5000	
0111	1111	1111	+5.0000	+2.5000	-1.0000	
1011	1111	1111	+2.5000	+1.2500	-0.5000	
1111	1111	1110	+0.0024	+0.0012	-0.0005	
1111	1111	1111	0.0000	0.0000	0.0000	
UNIPOLAR OUTPUT, COMPLEMENTARY BCD						
BCD INPUT CODE			UNIPOLAR OUTPUT RANGES			
MSB		LSB	0 to +10V	0 to +5V	0 to +2.5V	0 to -2mA
0110	0110	0110	+9.990	+4.995	+2.498	-1.2488
1000	1010	1111	+7.500	+3.750	+1.875	-0.9375
1010	1111	1111	+5.000	+2.5000	+1.250	-0.6250
1101	1010	1111	+2.5000	+1.250	+0.625	-0.3125
1111	1111	1110	+0.0100	+0.005	+0.003	-0.0013
1111	1111	1111	0.0000	0.0000	0.0000	0.0000
BIPOLAR OUTPUT, COMPLEMENTARY OFFSET BINARY						
INPUT CODE			BIPOLAR OUTPUT RANGES			
MSB		LSB	0 to +10V	0 to +5V	0 to +2.5V	0 to -2mA
0000	0000	0000	+9.9951	+4.9976	+2.4988	-0.9995
0011	1111	1111	+5.0000	+2.5000	+1.2500	-0.5000
0111	1111	1111	0.0000	0.0000	0.0000	0.0000
1011	1111	1111	-5.0000	-2.5000	-1.2500	+0.5000
1111	1111	1110	-9.9951	-4.9976	-2.4988	+0.9995
1111	1111	1111	-10.0000	-5.0000	-2.5000	+1.0000

### MECHANICAL DIMENSIONS (inches (mm))

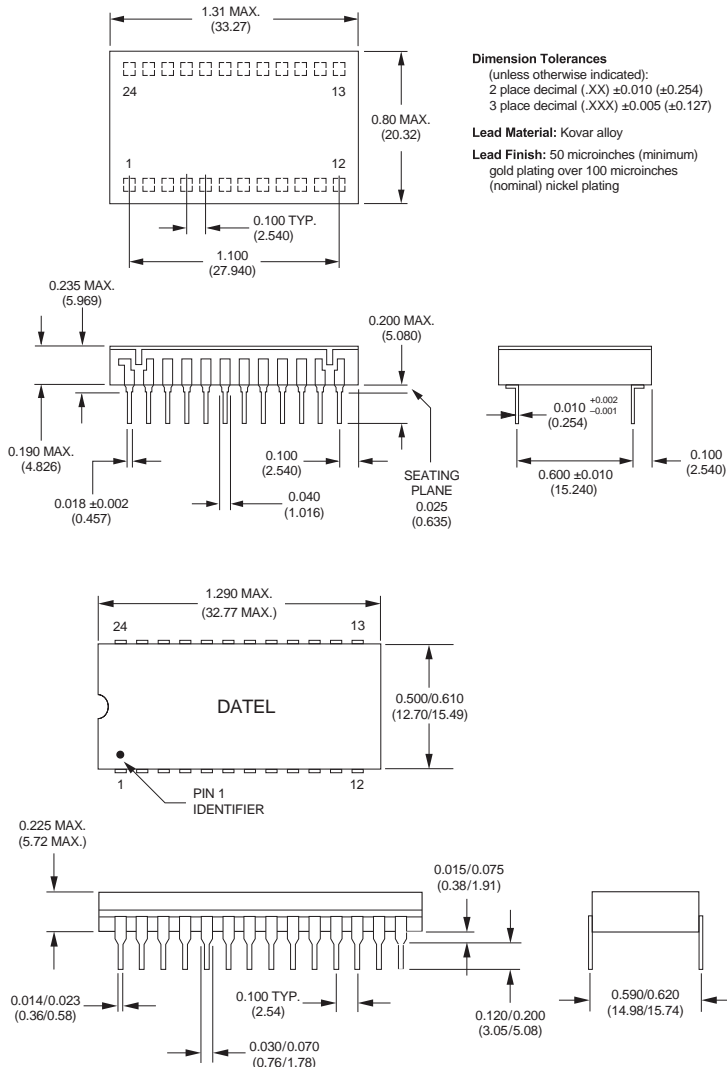

### ORDERING INFORMATION

MODEL	OPERATING TEMPERATURE RANGE	OUTPUT CODING	RoHS RATING
DAC-HZ12BGC	0 to +70°C	Binary	RoHS
DAC-HZ12BMC	0 to +70°C	Binary	RoHS
DAC-HZ12BME	-40 to +85°C	Binary	RoHS
DAC-HZ12BMM	-55 to +125°C	Binary	RoHS
DAC-HZ12BMM-QL	-55 to +125°C	Binary	RoHS
DAC-HZ12DGC	0 to +70°C	BCD	Non-RoHS
DAC-HZ12DGC-C	0 to +70°C	BCD	RoHS
DAC-HZ12DMC	0 to +70°C	BCD	Non-RoHS
DAC-HZ12DMC-C	0 to +70°C	BCD	RoHS
DAC-HZ12DME	-40 to +85°C	BCD	Non-RoHS
DAC-HZ12DME-C	-40 to +85°C	BCD	RoHS
DAC-HZ12DMM	-55 to +125°C	BCD	Non-RoHS
DAC-HZ12DMM-C	-55 to +125°C	BCD	RoHS
DAC-HZ12DMM-QL	-55 to +125°C	BCD	Non-RoHS
DAC-HZ12DMM-QL-C	-55 to +125°C	BCD	RoHS

Contact DATEL for information concerning our QL high-reliability screening program.

DATEL is a registered trademark of  
Murata Power Solutions, Inc.  
11 Cabot Boulevard, Mansfield, MA 02048-1151 USA  
ITAR and ISO 9001/14001 REGISTERED

Murata Power Solutions, Inc. makes no representation that the use of its products in the circuits described herein, or the use of other technical information contained herein, will not infringe upon existing or future patent rights. The descriptions contained herein do not imply the granting of licenses to make, use, or sell equipment constructed in accordance therewith. Specifications are subject to change without notice.

© 2012 Murata Power Solutions, Inc.

www.datel.com • e-mail: help@datel.com