



# PM-7548

CMOS 8-BIT  $\mu$ P COMPATIBLE  
12-BIT D/A CONVERTER

Precision Monolithics Inc.

## FEATURES

- 8-Bit Bus Compatible 12-Bit DAC
- Versatile Microprocessor Interface with Selectable Data Input Format and Data Override
- Faster Interface Timing
- High Accuracy: Low  $\pm 1/2$  LSB INL Error Over Temperature and  $\pm 1$  LSB Gain Error
- Superior Power Supply Rejection from +5V to +15V ..... 0.001%/ % Max
- Low Feedthrough Error and Digital Charge Injection
- Data Inputs Designed with ESD Protective Circuitry
- Narrow (0.3") DIP Packages Suitable for Auto-Insertion
- Superior Direct Replacement for AD7548
- Full Four Quadrant Multiplication

## APPLICATIONS

- Process Control
- Programmable Amplifiers
- Digitally Controlled Power Supplies
- Digitally Controlled Attenuators
- Digitally Controlled Filters

## ORDERING INFORMATION†

PACKAGE: 20-PIN**				
GAIN ERROR	NON-LINEARITY	MILITARY*	INDUSTRIAL	COMMERCIAL
		TEMPERATURE -55°C TO +125°C	TEMPERATURE -25°C TO +85°C	TEMPERATURE 0°C TO +70°C
$\pm 1$ LSB	$\pm 1/2$ LSB	PM7548AR	PM7548ER	PM7548GP
$\pm 2$ LSB	$\pm 1/2$ LSB	PM7548BR	PM7548FR	PM7548HP
$\pm 2$ LSB	$\pm 1/2$ LSB	PM7548BRC/883	—	PM7548HPC

\* For devices processed in total compliance to MIL-STD-883, add /883 after part number. Consult factory for 883 data sheet.

\*\*Package Designation: R Suffix = Hermetic DIP, RC Suffix = Leadless Chip Carrier, P Suffix = Plastic DIP, PC = Plastic Leadless Chip Carrier

† All commercial and industrial temperature range parts are available with burn-in. For ordering information see 1986 Data Book, Section 2.

## FUNCTIONAL BLOCK DIAGRAM

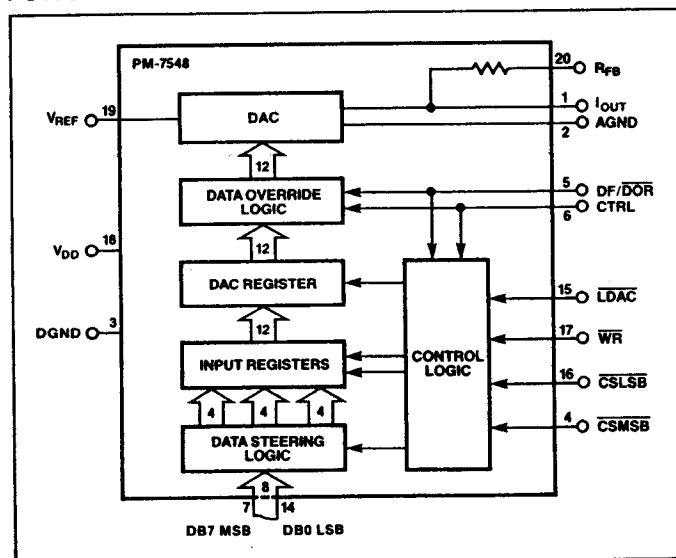

## CROSS REFERENCE

PMI	ADI	TEMPERATURE RANGE
PM7548AR PM7548BR	AD7548TD AD7548SD	MILITARY
PM7548ER PM7548FR	AD7548BQ AD7548AQ	INDUSTRIAL
PM7548GP PM7548HP	AD7548KN AD7548JN	COMMERCIAL

## GENERAL DESCRIPTION

The PM-7548 is a 12-bit resolution, current output, CMOS D/A converter with a microprocessor interface for 8-bit busses. Its improved accuracy and inputs designed with ESD protection circuitry make it a superior pin-compatible replacement to the industry standard 7548. These performance improvements permit the upgrading of existing designs with greater accuracy and ruggedness. Tighter linearity and gain error specifications may permit a reduced circuit parts count through the elimination of trimming components. The PM-7548 is available in standard plastic and CERP packages that are compatible with auto-insertion equipment.

The PM-7548's versatile interface allows data to be loaded into an output register in two bytes. The PM-7548 can accept data right or left justified, least or most significant byte first, under microprocessor control. Faster interface timing minimizes microprocessor wait states.

Analog output updating and the loading of new data into the input registers may be coincident or separated in time by use of the LDAC control input. This allows user control of data update and analog output update timing.

Data override control allows full-scale or zero-scale analog outputs without altering the contents of the DAC registers. This permits the user to perform circuit calibration without the need to load calibration data into the DAC registers.

## PIN CONNECTIONS

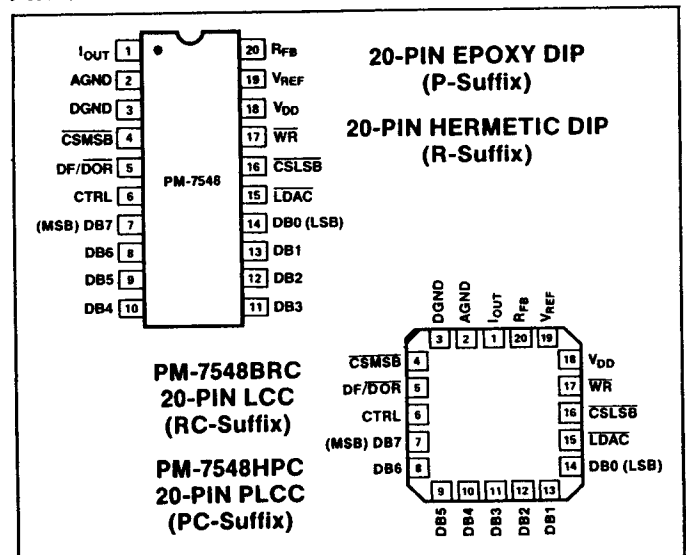

4/87, Rev. A

**ABSOLUTE MAXIMUM RATINGS** ( $T_A = +25^\circ\text{C}$ , unless otherwise noted.)

$V_{DD}$ (to GND) .....	+17V
$V_{REF}$ (to GND) .....	$\pm 25\text{V}$
$V_{RFB}$ (to GND) .....	$\pm 25\text{V}$
Digital Input Voltage Range .....	-0.3V to $V_{DD}$
Output Voltage (Pin 1, Pin 2) .....	-0.3V to $V_{DD}$
Power Dissipation (Any Package) .....	450mW
Derate Above $+75^\circ\text{C}$ .....	6mW/ $^\circ\text{C}$
<b>Operating Temperature Range</b>	
AR/BR/BRC Versions .....	$-55^\circ\text{C}$ to $+125^\circ\text{C}$
ER/FR Versions .....	$-25^\circ\text{C}$ to $+85^\circ\text{C}$
GP/HP/HPC Versions .....	$0^\circ\text{C}$ to $+70^\circ\text{C}$

Dice Junction Temperature .....	$+150^\circ\text{C}$
Storage Temperature .....	$-65^\circ\text{C}$ to $+150^\circ\text{C}$
Lead Temperature (Soldering, 60 sec) .....	$300^\circ\text{C}$

**CAUTION:**

1. Do not apply voltages higher than  $V_{DD}$  or less than GND potential on any terminal except  $V_{REF}$  (Pin 17) and  $R_{FB}$  (Pin 18).
2. The digital control inputs are zener protected, however, permanent damage may occur on unprotected units from high-energy electrostatic fields. Keep units in conductive foam at all times until ready to use.
3. Use proper anti-static handling procedures.
4. Absolute Maximum Ratings apply to both packaged devices and dice. Stresses above those listed under Absolute Maximum Ratings may cause permanent damage to the device.

**ELECTRICAL CHARACTERISTICS** at  $V_{DD} = +5\text{V}$ ,  $+12\text{V}$ , or  $+15\text{V}$ ;  $V_{REF} = +10\text{V}$ ;  $V_{OUT} = V_{AGND} = V_{DGND} = 0\text{V}$ ;  $T_A = -55^\circ\text{C}$  to  $+125^\circ\text{C}$  for PM-7548AR/BR/BRC,  $T_A = -25^\circ\text{C}$  to  $+85^\circ\text{C}$  for PM-7548ER/FR, and  $T_A = 0^\circ\text{C}$  to  $+70^\circ\text{C}$  for PM-7548GP/HP/HPC, unless otherwise noted.

PARAMETER	SYMBOL	CONDITIONS	PM-7548			UNITS
			MIN	TYP	MAX	
<b>STATIC ACCURACY</b>						
Resolution	N		12	—	—	Bits
Integral Nonlinearity (Note 1)	INL		—	—	1/2	LSB
Differential Nonlinearity (Note 2)	DNL	PM-7548A/E/G PM-7548B/F/H	—	—	1/2 1	LSB
Gain Error (Note 3)	$G_{FSE}$	$T_A = +25^\circ\text{C}$ PM-7548A/E/G	—	—	1	LSB
		PM-7548B/F/H	—	—	2	
		$T_A = \text{Full Temperature Range}$ PM-7548A/E/G	—	—	2	
		PM-7548B/F/H	—	—	3	
Gain Temperature Coefficient (Note 6)	$TCG_{FS}$		—	$\pm 1$	$\pm 5$	ppm/ $^\circ\text{C}$
Power Supply Rejection Ratio	PSRR	$T_A = +25^\circ\text{C}$	—	—	$\pm 0.001$	%/%
		$T_A = \text{Full Temperature Range}$	—	—	$\pm 0.002$	
Output Leakage Current (Notes 4, 5)	$I_{LKG}$	$T_A = +25^\circ\text{C}$	—	$\pm 0.5$	$\pm 5$	nA
		$T_A = \text{Full Temperature Range}$ PM-7548A/B	—	$\pm 12$	$\pm 100$	
		PM-7548E/F/G/H	—	—	$\pm 25$	
Feedthrough Error (Note 6)	FT	$V_{REF} = 20\text{V}_{p-p}$ at $f = 10\text{kHz}$ All digital inputs LOW	—	—	5	mV <sub>p-p</sub>
Zero Scale Error (Notes 12, 13)	$I_{ZSE}$	$T_A = +25^\circ\text{C}$	—	0.002	—	LSB
		$T_A = \text{Full Temperature Range}$ PM-7548A/B	—	0.07	—	
		PM-7548E/F/G/H	—	0.01	—	
Input Resistance (Note 9)	$R_{IN}$		7	11	15	k $\Omega$
<b>AC PERFORMANCE</b>						
Output Current Settling-Time (Notes 6, 7, 8)	$t_s$	$T_A = +25^\circ\text{C}$	—	—	1	$\mu\text{s}$
Digital to Analog Glitch Energy (Notes 6, 11)	Q	$V_{REF} = 0\text{V}$ $I_{OUT}$ Load = $100\Omega$ $C_{Ext} = 13\text{pF}$ DAC register loaded alternately with all 0s and all 1s	—	—	200	nVs