



20Mbps, +3.3V, SOT23 RS-485/ RS-422 Transmitters

MAX3293/MAX3294/MAX3295

General Description

The MAX3293/MAX3294/MAX3295 low-power, high-speed transmitters for RS-485/RS-422 communication operate from a single +3.3V power supply. These devices contain one differential transmitter. The MAX3295 transmitter operates at data rates up to 20Mbps, with an output skew of less than 5ns, and a guaranteed driver propagation delay below 25ns. The MAX3293 (250kbps) and MAX3294 (2.5Mbps) are slew-rate limited to minimize EMI and reduce reflections caused by improperly terminated cables.

The MAX3293/MAX3294/MAX3295 output level is guaranteed at +1.5V with a standard 54Ω load, compliant with RS-485 specifications. The transmitter draws 5mA of supply current when unloaded, and 1μA in low-power shutdown mode (DE = GND).

Hot-swap circuitry eliminates false transitions on the data cable during circuit initialization or connection to a live backplane, and short-circuit current limiting and thermal-shutdown circuitry protect the driver against excessive power dissipation.

The MAX3293/MAX3294/MAX3295 are offered in a 6-pin SOT23 package, and are specified over the automotive temperature range.

Applications

- RS-485/RS-422 Communications
- Clock Distribution
- Telecom Equipment
- Automotive
- Security Equipment
- Point-of-Sale Equipment
- Industrial Control

Pin Configuration

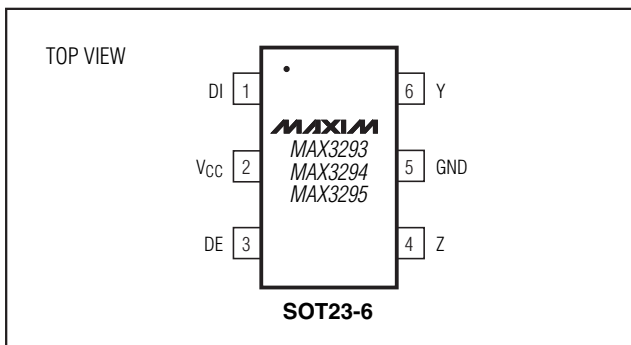

Features

- ◆ Space-Saving 6-Pin SOT23 Package
- ◆ 250kbps/2.5Mbps/20Mbps Data Rates Available
- ◆ Operate from a Single +3.3V Supply
- ◆ ESD Protection
±9kV—Human Body Model
- ◆ Slew-Rate Limited for Errorless Data Transmission (MAX3293/MAX3294)
- ◆ 1μA Low-Current Shutdown Mode
- ◆ -7V to +12V Common-Mode Input Voltage Range
- ◆ Current Limiting and Thermal Shutdown for Driver-Overload Protection
- ◆ Hot-Swap Inputs for Telecom Applications
- ◆ Automotive Temperature Range (-40°C to +125°C)

Ordering Information

PART	TEMP RANGE	PIN-PACKAGE
MAX3293AUT-T	-40°C to +125°C	6 SOT23-6
MAX3294AUT-T	-40°C to +125°C	6 SOT23-6
MAX3295AUT-T	-40°C to +125°C	6 SOT23-6

Selector Guide

PART	MAXIMUM DATA RATE (Mbps)	SLEW-RATE LIMITED	TOP MARK
MAX3293AUT-T	0.25	Yes	ABNI
MAX3294AUT-T	2.5	Yes	ABNJ
MAX3295AUT-T	20	No	ABNK

Typical Operating Circuit

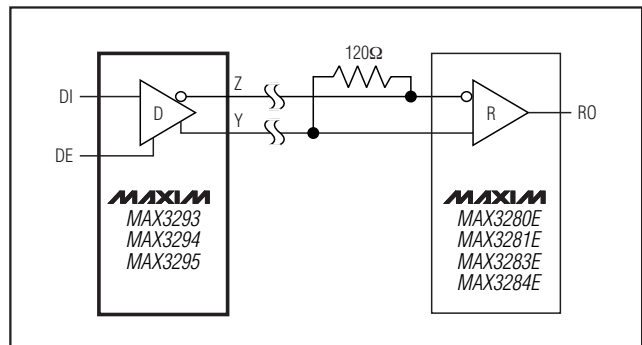

For pricing, delivery, and ordering information, please contact Maxim/Dallas Direct! at 1-888-629-4642, or visit Maxim's website at www.maxim-ic.com.

20Mbps, +3.3V, SOT23 RS-485/ RS-422 Transmitters

ABSOLUTE MAXIMUM RATINGS

(All voltages referenced to GND, unless otherwise noted.)

Supply Voltage (V _{CC})	+6V
DE, DI	-0.3V to +6V
Y, Z	-7V to +12.5V
Maximum Continuous Power Dissipation (T _A = +70°C)	
6-Pin SOT23 (derate 6.25mW/°C above +70°C)	500mW

Operating Temperature Ranges

MAX32_ _AUT	-40°C to +125°C
Storage Temperature Range	-65°C to +160°C
Junction Temperature	+160°C
Lead Temperature (soldering, 10s)	+300°C

Stresses beyond those listed under "Absolute Maximum Ratings" may cause permanent damage to the device. These are stress ratings only, and functional operation of the device at these or any other conditions beyond those indicated in the operational sections of the specifications is not implied. Exposure to absolute maximum rating conditions for extended periods may affect device reliability.

ELECTRICAL CHARACTERISTICS

(V_{CC} = +3.3V ±5%, T_A = T_{MIN} to T_{MAX}, unless otherwise noted. Typical values are at V_{CC} = +3.3V and T_A = +25°C.) (Notes 1, 2)

PARAMETER	SYMBOL	CONDITIONS	MIN	TYP	MAX	UNITS
POWER SUPPLY						
Supply Voltage	V _{CC}		3.135	3.300	3.465	V
Supply Current in Normal Operation	I _Q	No load, DI = V _{CC} or GND, DE = V _{CC}			5	mA
Supply Current in Shutdown Mode	I _{SHDN}	No load, DE = GND		1	10	μA
DRIVER						
Differential Driver Output	V _{OD}	Figure 1, DE = V _{CC} , DI = GND or V _{CC}	R = 50Ω (RS-422), T _A ≤ +85°C	2.0	V _{CC}	V
			R = 27Ω (RS-485), T _A ≤ +85°C	1.5	V _{CC}	
Change in Magnitude of Differential Output Voltage	ΔV _{OD}	Figure 1, R = 27Ω or 50Ω, DE = V _{CC} (Note 3)			0.2	V
Driver Common-Mode Output Voltage	V _{OC}	Figure 1, R = 27Ω or 50Ω, DE = V _{CC} , DI = V _{CC} or GND	-1		+3	V
Change in Magnitude of Common-Mode Voltage	ΔV _{OC}	Figure 1, R = 27Ω or 50Ω (Note 3)			0.2	V
DRIVER LOGIC						
Input High Voltage	V _{IH}	DE, DI	2.0			V
Input Low Voltage	V _{IL}	DE, DI			0.8	V
Input Current	I _{IN}	DE, DI	-2		+2	μA
Output Leakage	I _O	Y, Z DE = GND, V _{CC} = GND or +3.3V	V _{IN} = +12V	-20	+20	μA
			V _{IN} = -7V	-20	+20	
Driver Short-Circuit Foldback Output Current	I _{OSFD}	(V _{CC} - 1V) ≤ V _{OUT} ≤ +12V, output high	+25			mA
		-7V ≤ V _{OUT} ≤ 1V, output high			-25	
Driver Short-Circuit Output Current	I _{OSD}	0 ≤ V _{OUT} ≤ +12V, output low	-250			mA
		-7V ≤ V _{OUT} ≤ V _{CC} , output high			+250	
Thermal-Shutdown Threshold	T _{TS}			160		°C
Thermal-Shutdown Hysteresis	T _{TSH}			40		°C
ESD Protection		Y, Z	Human Body Model		±9	kV

20Mbps, +3.3V, SOT23 RS-485/ RS-422 Transmitters

MAX3293/MAX3294/MAX3295

SWITCHING CHARACTERISTICS (MAX3293)

(V_{CC} = +3.3V ±5%, T_A = +25°C, unless otherwise noted. Typical values are at V_{CC} = +3.3V.)

PARAMETER	SYMBOL	CONDITIONS	MIN	TYP	MAX	UNITS
Driver Propagation Delay	t _{PLH}	Figures 2, 3; R _{DIFF} = 54Ω, C _L = 50pF	400		1300	ns
	t _{PHL}		400		1300	
Driver Differential Output Rise or Fall Time	t _R	Figures 2, 3; R _{DIFF} = 54Ω, C _L = 50pF	400		1200	ns
	t _F		400		1200	
Driver Output Skew	t _{SKEW}	Figures 2, 3; R _{DIFF} = 54Ω, C _L = 50pF, t _{SKEW} = t _{PLH} - t _{PHL} (Note 5)	-400		+400	ns
Differential Driver Output Skew	t _{DSKEW}	Figures 2, 3; R _{DIFF} = 54Ω, C _L = 50pF	-100		+100	ns
Maximum Data Rate		Figures 2, 3; R _{DIFF} = 54Ω, C _L = 50pF	250			kbps
Driver Enable to Output High	t _{ZH}	Figures 4, 5; S2 closed, R _L = 500Ω, C _L = 100pF			2000	ns
Driver Enable to Output Low	t _{ZL}	Figures 4, 5; S1 closed, R _L = 500Ω, C _L = 100pF			2000	ns
Driver Disable Time from Low	t _{LZ}	Figures 4, 5; S1 closed, R _L = 500Ω, C _L = 100pF			1000	ns
Driver Disable Time from High	t _{HZ}	Figures 4, 5; S2 closed, R _L = 500Ω, C _L = 100pF			1000	ns
Device-to-Device Propagation Delay Matching		Same power supply, maximum temperature difference between devices = +30°C (Note 5)			900	ns

SWITCHING CHARACTERISTICS (MAX3294)

(V_{CC} = +3.3V ±5%, T_A = +25°C, unless otherwise noted. Typical values are at V_{CC} = +3.3V.)

PARAMETER	SYMBOL	CONDITIONS	MIN	TYP	MAX	UNITS
Driver Propagation Delay	t _{PLH}	Figures 2, 3; R _{DIFF} = 54Ω, C _L = 50pF	24		70	ns
	t _{PHL}		24		70	
Driver Differential Output Rise or Fall Time	t _R	Figures 2, 3; R _{DIFF} = 54Ω, C _L = 50pF	10		70	ns
	t _F		10		70	
Driver Output Skew	t _{SKEW}	Figures 2, 3; R _{DIFF} = 54Ω, C _L = 50pF, t _{SKEW} = t _{PLH} - t _{PHL} (Note 5)	-40		+40	ns
Differential Driver Output Skew	t _{DSKEW}	Figures 2, 3; R _{DIFF} = 54Ω, C _L = 50pF	-6		+6	ns
Maximum Data Rate		Figures 2, 3; R _{DIFF} = 54Ω, C _L = 50pF	2.5			Mbps
Driver Enable to Output High	t _{ZH}	Figures 4, 5; S2 closed, R _L = 500Ω, C _L = 100pF			400	ns
Driver Enable to Output Low	t _{ZL}	Figures 4, 5; S1 closed, R _L = 500Ω, C _L = 100pF			400	ns
Driver Disable Time from Low	t _{LZ}	Figures 4, 5; S1 closed, R _L = 500Ω, C _L = 100pF			100	ns
Driver Disable Time from High	t _{HZ}	Figures 4, 5; S2 closed, R _L = 500Ω, C _L = 100pF			100	ns
Device-to-Device Propagation Delay Matching		Same power supply, maximum temperature difference between devices = +30°C (Note 5)			46	ns

20Mbps, +3.3V, SOT23 RS-485/ RS-422 Transmitters

SWITCHING CHARACTERISTICS (MAX3295)

($V_{CC} = +3.3V \pm 5\%$, $T_A = +25^\circ C$, unless otherwise noted. Typical values are at $V_{CC} = +3.3V$.)

PARAMETER	SYMBOL	CONDITIONS	MIN	TYP	MAX	UNITS
Driver Propagation Delay	t_{PLH}	Figures 2, 3; $R_{DIFF} = 54\Omega$, $C_L = 50pF$			25	ns
	t_{PHL}				25	
Driver Differential Output Rise or Fall Time	t_R	Figures 2, 3; $R_{DIFF} = 54\Omega$, $C_L = 50pF$	$T_A = -40^\circ C$ to $+125^\circ C$		18.5	ns
			$T_A < +85^\circ C$		15	
	$T_A = -40^\circ C$ to $+125^\circ C$		18.5			
	$T_A < +85^\circ C$		15			
Driver Output Skew	t_{SKEW}	Figures 2, 3; $R_{DIFF} = 54\Omega$, $C_L = 50pF$, $t_{SKEW} = t_{PLH} - t_{PHL} $	5			ns
Differential Driver Output Skew	t_{DSKEW}	Figures 2, 3; $R_{DIFF} = 54\Omega$, $C_L = 50pF$	5			ns
Maximum Data Rate		Figures 2, 3; $R_{DIFF} = 54\Omega$, $C_L = 50pF$, $T_A \leq +85^\circ C$	20			Mbps
		Figures 2, 3; $R_{DIFF} = 54\Omega$, $C_L = 50pF$	16			
Driver Enable to Output High	t_{ZH}	Figures 4, 5; S2 closed, $R_L = 500\Omega$, $C_L = 100pF$			400	ns
Driver Enable to Output Low	t_{ZL}	Figures 4, 5; S1 closed, $R_L = 500\Omega$, $C_L = 100pF$			400	ns
Driver Disable Time from Low	t_{LZ}	Figures 4, 5; S1 closed, $R_L = 500\Omega$, $C_L = 100pF$			100	ns
Driver Disable Time from High	t_{HZ}	Figures 4, 5; S2 closed, $R_L = 500\Omega$, $C_L = 100pF$			100	ns
Device-to-Device Propagation Delay Matching		Same power supply, maximum temperature difference between devices = $+30^\circ C$ (Note 5)			25	ns

Note 1: Devices production tested at $+25^\circ C$. Limits over the operating temperature range are guaranteed by design.

Note 2: All currents into the device are positive; all currents out of the device are negative. All voltages are referenced to device ground, unless otherwise noted.

Note 3: ΔV_{OD} and ΔV_{OC} are the changes in V_{OD} and V_{OC} , respectively, when the DI input changes state.

Note 4: The maximum current applies to peak current just prior to foldback current limiting.

Note 5: Not production tested. Guaranteed by design.

20Mbps, +3.3V, SOT23 RS-485/ RS-422 Transmitters

MAX3293/MAX3294/MAX3295

Test Circuits and Timing Diagrams

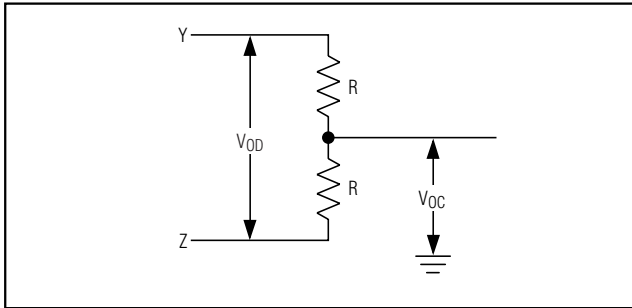

Figure 1. Driver DC Test Load

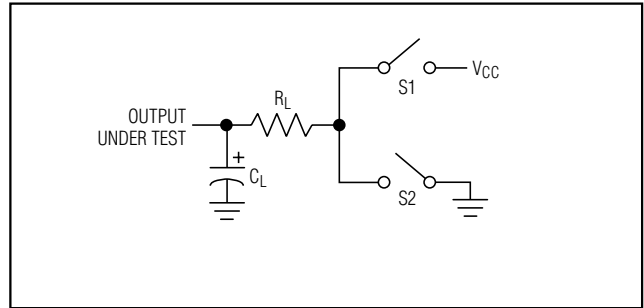

Figure 4. Enable/Disable Timing Test Load

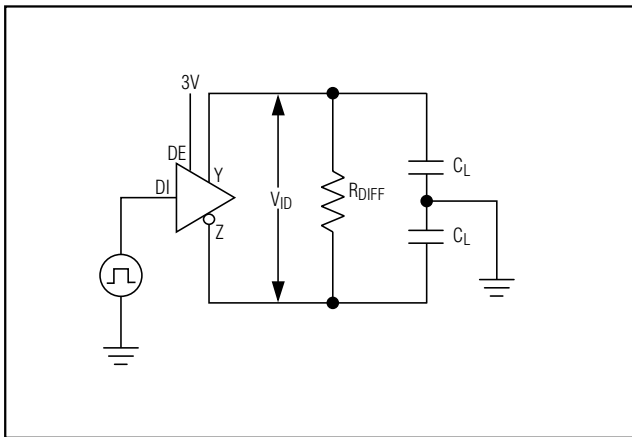

Figure 2. Driver Timing Test Circuit

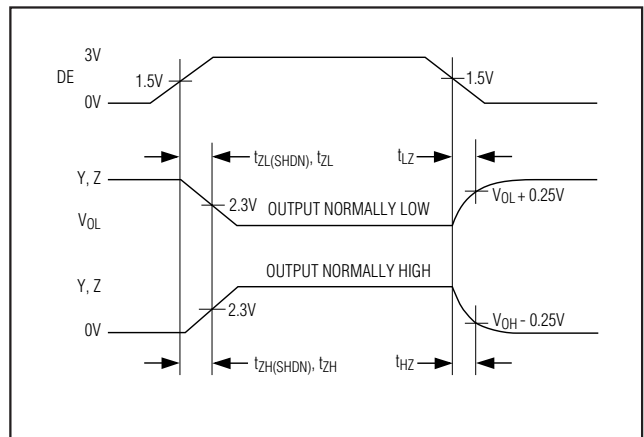

Figure 5. Driver Enable and Disable Times

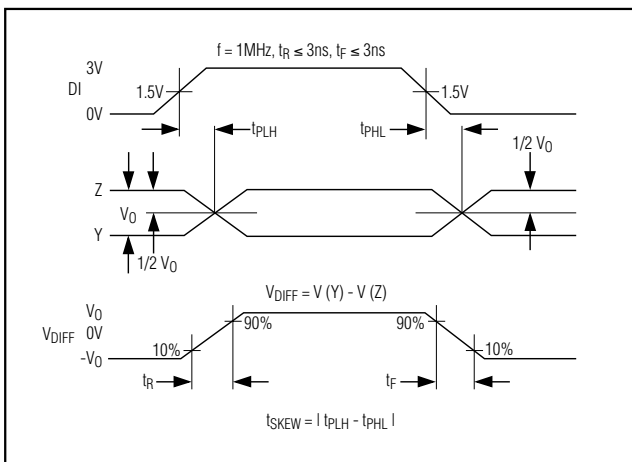
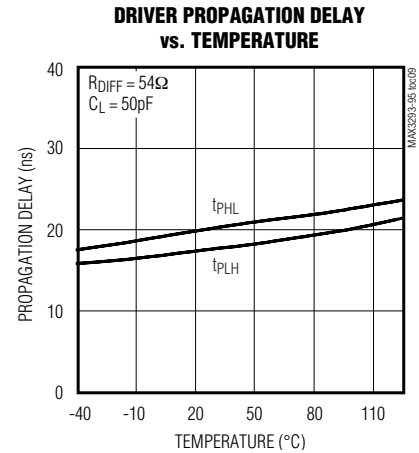
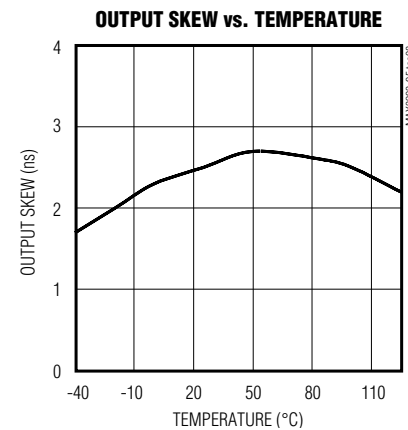
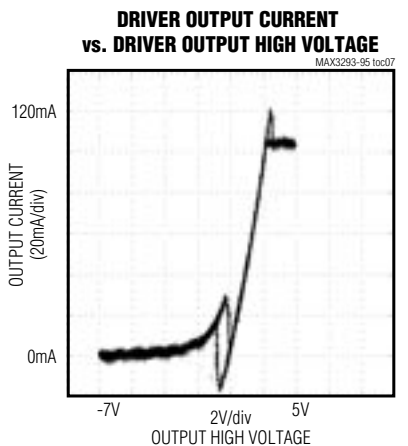
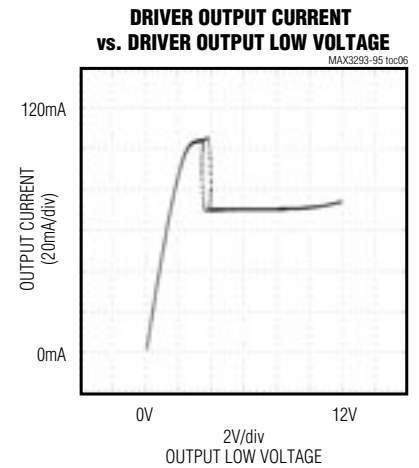
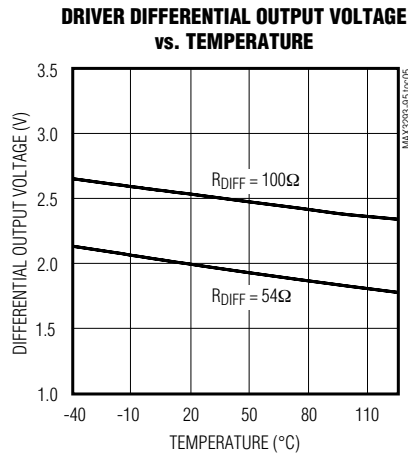
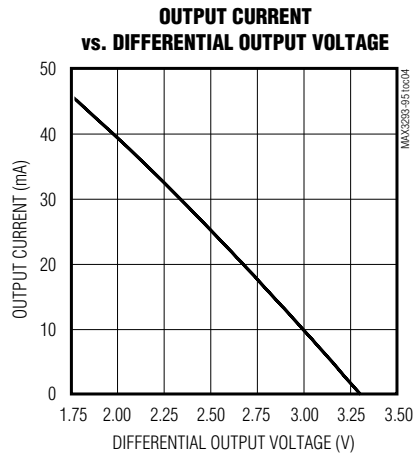
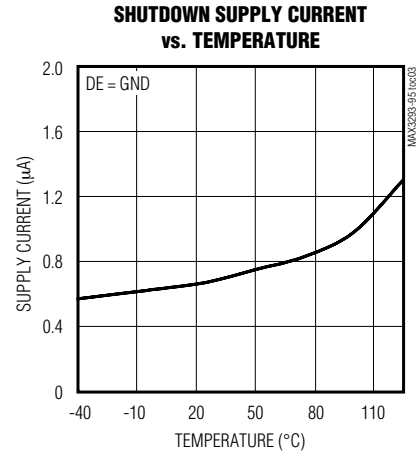
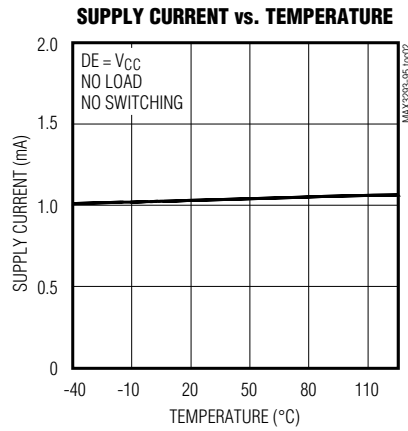
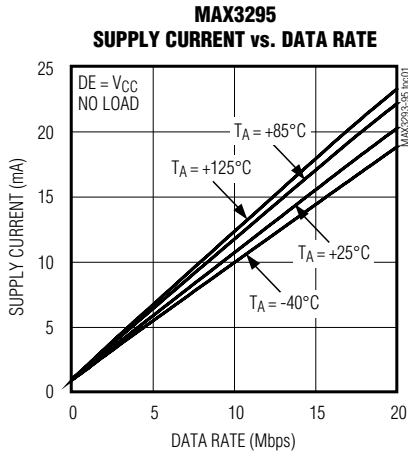

Figure 3. Driver Propagation Delays

20Mbps, +3.3V, SOT23 RS-485/ RS-422 Transmitters

Typical Operating Characteristics

($V_{CC} = +3.3V$, $T_A = +25^\circ C$, unless otherwise noted.)



20Mbps, +3.3V, SOT23 RS-485/ RS-422 Transmitters

Typical Operating Characteristics (continued)

(V_{CC} = +3.3V, T_A = +25°C, unless otherwise noted.)

MAX3293/MAX3294/MAX3295

DRIVER PROPAGATION DELAY

MAX3293-95 tpc10

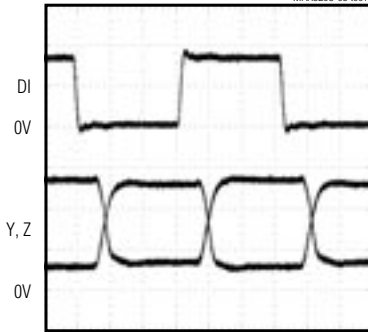

20ns/div

Y, Z: 1V/div
DI: 2V/div

ENABLE RESPONSE TIME

MAX3293-95 tpc11

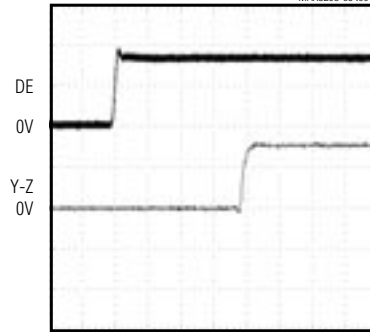

40ns/div

Y, Z, DE: 2V/div

UNLOADED DRIVER OUTPUT WAVEFORM (f_{IN} = 16Mbps)

MAX3293-95 tpc12

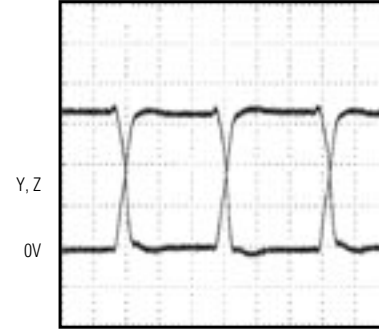

20ns/div

Y, Z: 1V/div

LOADED DRIVER OUTPUT WAVEFORM (f_{IN} = 16Mbps)

MAX3293-95 tpc13

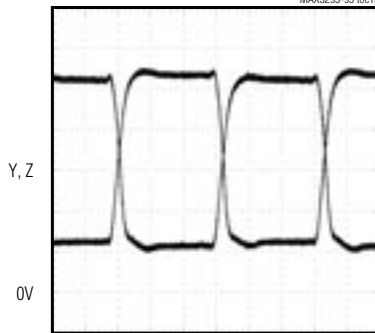

20ns/div

Y, Z: 500mV/div

EYE DIAGRAM (f_{IN} = 20Mbps)

MAX3293-95 tpc14

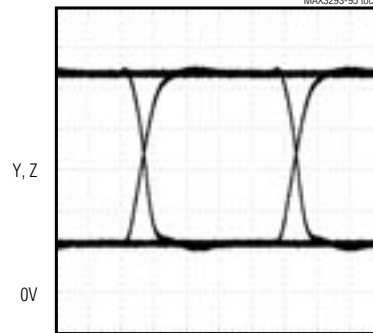

10ns/div

Y, Z: 500mV/div

Pin Description

PIN	NAME	FUNCTION
1	DI	Driver Input. A logic low on DI forces the noninverting output (Y) low and the inverting output (Z) high. A logic high on DI forces the noninverting output (Y) high and the inverting output (Z) low.
2	V _{CC}	Positive Supply. V _{CC} = +3.3V ±5%. Bypass V _{CC} to GND with a 0.1μF capacitor.
3	DE	Driver Output Enable. Force DE high to enable driver. Pull DE low to disable the driver. Hot-swap input, see the <i>Hot-Swap Capability</i> section.
4	Z	Inverting RS-485/RS-422 Output
5	GND	Ground
6	Y	Noninverting RS-485/RS-422 Output

20Mbps, +3.3V, SOT23 RS-485/RS-422 Transmitters

Detailed Description

The MAX3293/MAX3294/MAX3295 are low-power transmitters for RS-485/RS-422 communication. The MAX3295 operates at data rates up to 20Mbps, the MAX3294 up to 2.5Mbps (slew-rate limited), and the MAX3293 up to 250kbps (slew-rate limited). These devices are enabled using an active-high driver enable (DE) input. When disabled, outputs enter a high-impedance state, and the supply current reduces to 1µA.

The MAX3293/MAX3294/MAX3295 have a hot-swap input structure that prevents disturbance on the differential signal lines when a circuit board is plugged into a “hot” backplane (see the *Hot-Swap Capability* section). Drivers are also short-circuit current limited and are protected against excessive power dissipation by thermal-shutdown circuitry.

Driver

The driver accepts a single-ended, logic-level input (DI) and translates it to a differential RS-485/RS-422 level output (Y and Z). Driving DE high enables the driver, while pulling DE low places the driver outputs (Y and Z) into a high-impedance state (see Table 1).

Low-Power Shutdown

Force DE low to disable the MAX3293/MAX3294/MAX3295. In shutdown mode, the device consumes a maximum of 10µA of supply current.

Hot-Swap Capability

Hot-Swap Input

When circuit boards are inserted into a “hot” or powered backplane, disturbances to the enable can lead to data errors. Upon initial circuit board insertion, the processor undergoes its power-up sequence. During this period, the output drivers are high impedance and are unable to drive the DE input of the MAX3293/MAX3294/MAX3295 to a defined logic level. Leakage currents up to 10µA from the high-impedance output could cause DE to drift to an incorrect logic state. Additionally, parasitic circuit board capacitance could

Table 1. MAX3293/MAX3294/MAX3295 (RS-485/RS-422) Transmitting Function Table

INPUTS		OUTPUTS	
DE	DI	Y	Z
0	X	Shutdown	Shutdown
1	0	0	1
1	1	1	0

X = Don't care.

cause coupling of VCC or GND to DE. These factors could improperly enable the driver.

The MAX3293/MAX3294/MAX3295 eliminate all above issues with hot-swap circuitry. When VCC rises, an internal pulldown circuit holds DE low for approximately 10µs. After the initial power-up sequence, the pulldown circuit becomes transparent, resetting the hot-swap tolerable input.

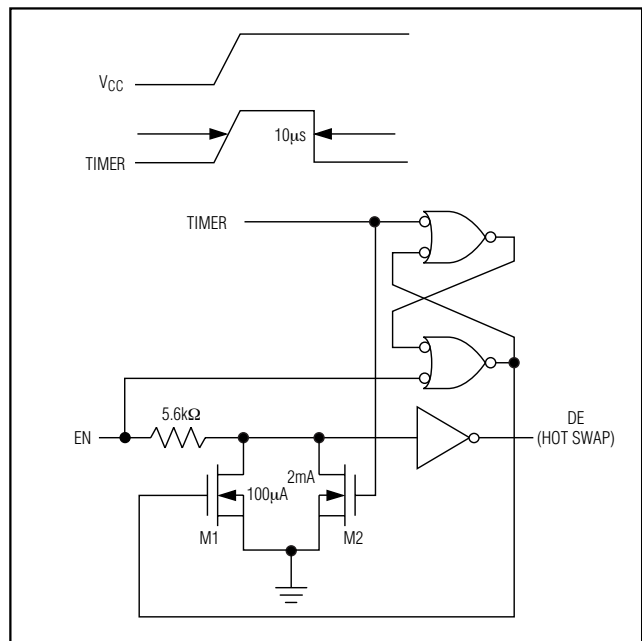

Figure 6. Simplified Structure of the Driver Enable Input (DE)

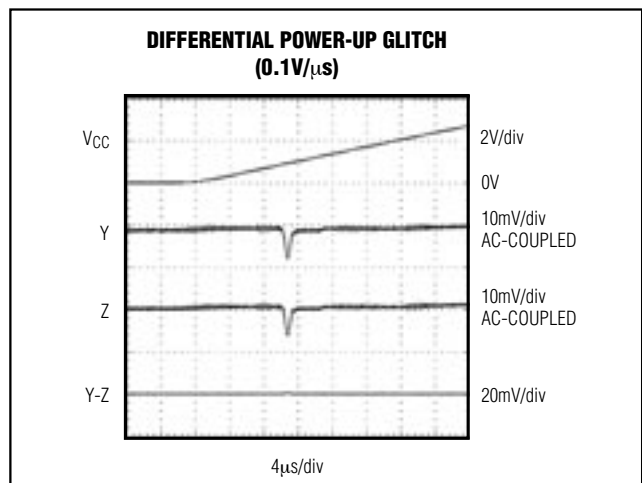

Figure 7. Differential Power-Up Glitch (0.1V/µs)

20Mbps, +3.3V, SOT23 RS-485/ RS-422 Transmitters

MAX3293/MAX3294/MAX3295

Hot-Swap Input Circuitry

The MAX3293/MAX3294/MAX3295 enable input features hot-swap capability. At the input, there are two NMOS devices, M1 and M2 (Figure 6). When V_{CC} ramps from zero, an internal $10\mu s$ timer turns on M2 and sets the SR latch, which also turns on M1. Transistors M2, a 2mA current sink, and M1, a $100\mu A$ current sink, pull DE to GND through a $5.6k\Omega$ resistor. M2 is designed to pull DE to the disabled state against an external parasitic capacitance up to $100pF$ that may drive DE high. After $10\mu s$, the timer deactivates M2 while M1 remains on, holding DE low against three-state leakages that can drive DE high. M1 remains on until an external source overcomes the required input current. At this time, the SR latch resets and M1 turns

off. When M1 turns off, DE reverts to a standard, high-impedance CMOS input. Whenever V_{CC} drops below 1V, the hot-swap input is reset.

Hot-Swap Line Transient

During a hot-swap event when the driver is connected to the line and is powered up, the driver must not cause the differential signal to drop below 200mV. Figures 7, 8, and 9 show the results of the MAX3295 during power-up for three different V_{CC} ramp rates ($0.1V/\mu s$, $1V/\mu s$, and $10V/\mu s$). The photos show the V_{CC} ramp, the single-ended signal on each side of the 100Ω termination, as well as the differential signal across the termination.

ESD Protection

Human Body Model

Figure 10 shows the Human Body Model, and Figure 11 shows the current waveform it generates when discharged into low impedance. This model consists of a $100pF$ capacitor charged to the ESD voltage of interest, which is then discharged into the device through a $1.5k\Omega$ resistor.

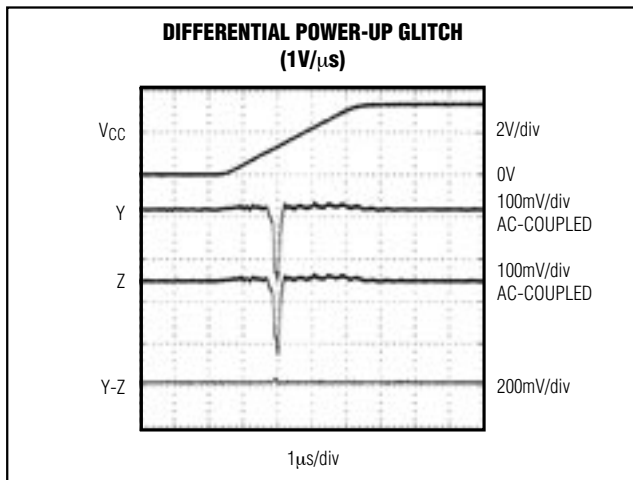

Figure 8. Differential Power-Up Glitch ($1V/\mu s$)

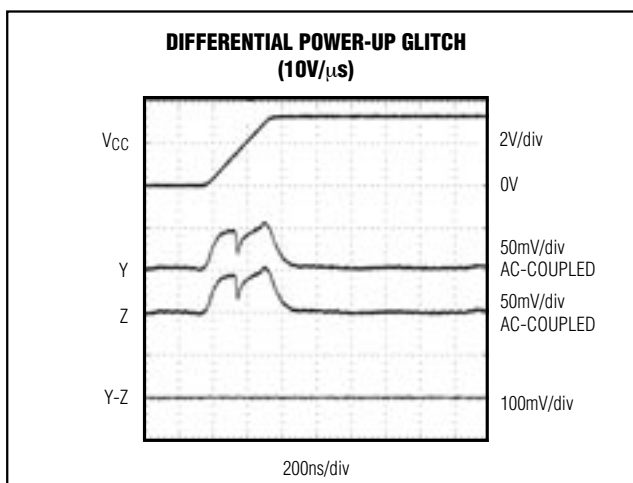

Figure 9. Differential Power-Up Glitch ($10V/\mu s$)

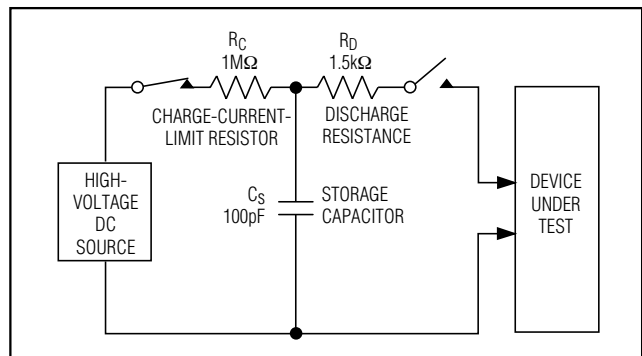

Figure 10. Human Body ESD Test

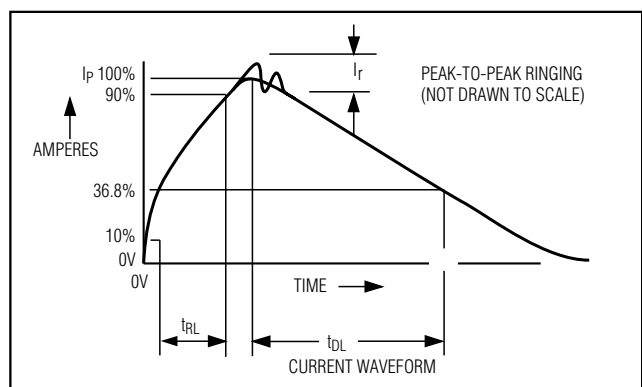

Figure 11. Current Waveform

20Mbps, +3.3V, SOT23 RS-485/ RS-422 Transmitters

Reduced EMI and Reflections (MAX3293/MAX3294)

The MAX3293/MAX3294 are slew-rate limited, minimizing EMI and reducing reflections caused by improperly terminated cables. Figure 12 shows Fourier analysis of the MAX3295 transmitting a 125kHz signal. High-frequency harmonics with large amplitudes are evident. Figure 13 shows the same information, but for the slew-rate-limited MAX3293, transmitting the same signal. The high-frequency harmonics have much lower amplitudes, and the potential for EMI is significantly reduced.

To minimize reflections, the line should be terminated at both ends in its characteristic impedance, and stub lengths off the main line should be kept as short as possible. The slew-rate-limited MAX3293 and MAX3294 are more tolerant of imperfect termination.

Driver Output Protection

Two mechanisms prevent excessive output current and power dissipation caused by faults or by bus contention. The first, a foldback current limit on the output stage, provides immediate protection against short circuits over the whole common-mode voltage range (see the *Typical Operating Characteristics*). The second, a thermal-shut-down circuit, forces the driver outputs into a high-impedance state if the die temperature exceeds +160°C.

Chip Information

TRANSISTOR COUNT: 263

PROCESS: BiCMOS

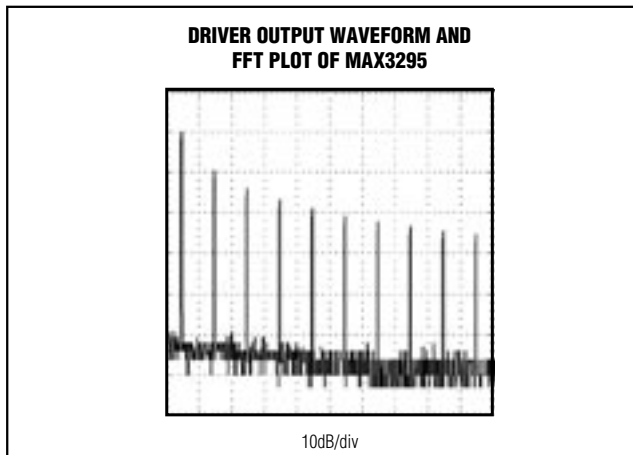

Figure 12. Driver Output Waveform and FFT Plot of MAX3295 Transmitting a 125kHz Signal

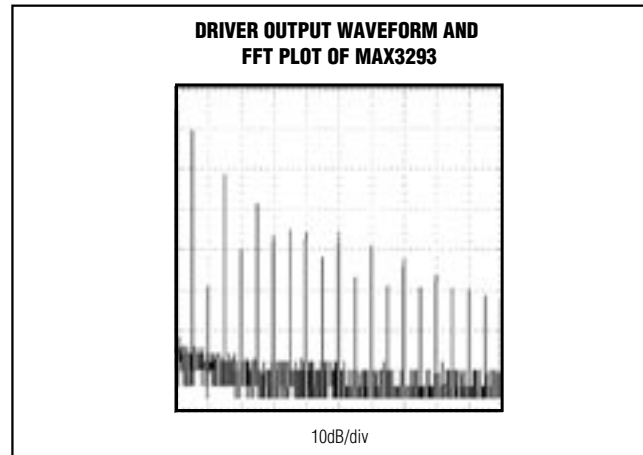

Figure 13. Driver Output Waveform and FFT Plot of MAX3293 Transmitting a 125kHz Signal

20Mbps, +3.3V, SOT23 RS-485/ RS-422 Transmitters

Package Information

(The package drawing(s) in this data sheet may not reflect the most current specifications. For the latest package outline information go to www.maxim-ic.com/packages.)

MAX3293/MAX3294/MAX3295

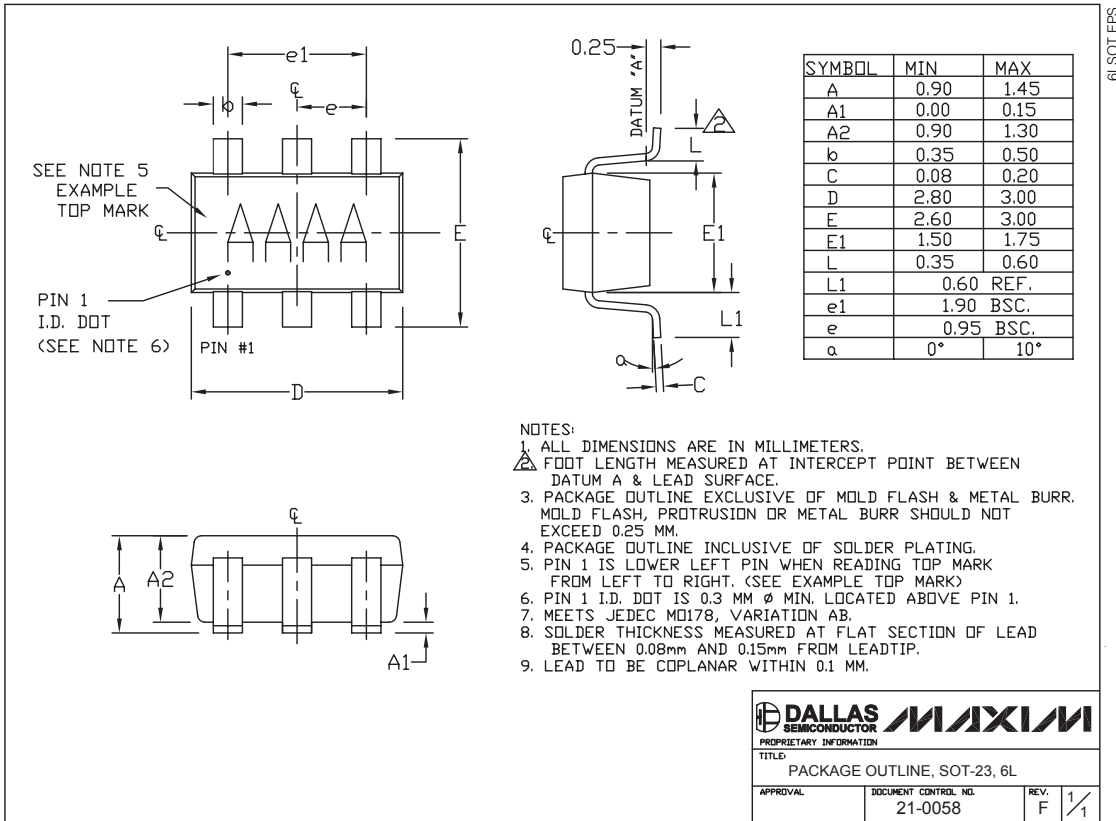

Maxim cannot assume responsibility for use of any circuitry other than circuitry entirely embodied in a Maxim product. No circuit patent licenses are implied. Maxim reserves the right to change the circuitry and specifications without notice at any time.

Maxim Integrated Products, 120 San Gabriel Drive, Sunnyvale, CA 94086 408-737-7600 _____ 11