

Couplers with Connectors (H Type)

HDH Series

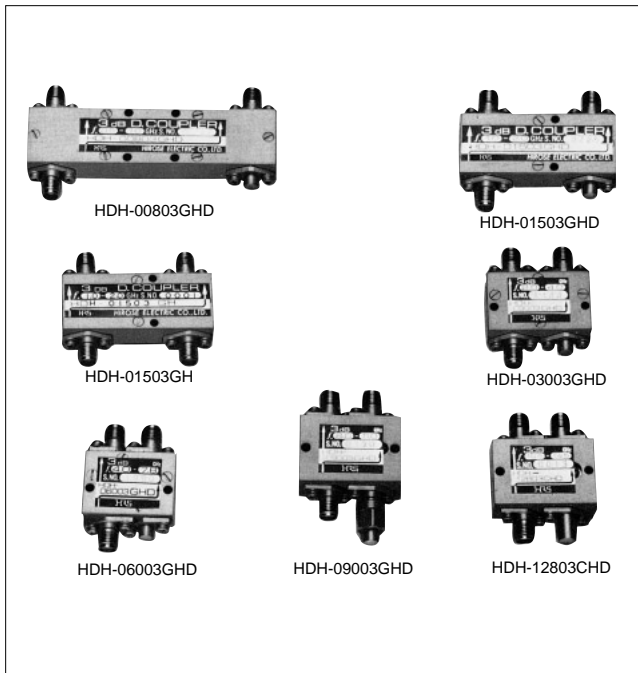

■ Features

1. High Performance

The high frequency characteristics feature extremely low loss, a high degree of matching, and high isolation.

2. Power Uniform Distribution and 90° Phase Difference Type

This is a one input, two output (or two input, one output) power uniform distribution type having a 90° phase difference between the two outputs (or two inputs).

3. Miniature and Lightweight

Corrosion-resistant aluminum is used for the case and the Hirose Electric original pattern design, which uses a stripline triplate method, enables the couplers to be miniature and lightweight.

4. Couplers with SMA Connectors

Use of SMA connectors (Hirose Electric HRM Series) which feature stainless steel for the exterior cladding make these couplers durable.

■ Product Specifications

Ratings	Frequency range (Note) Characteristic impedance Maximum Input Power (Note)	0.5 to 14.5 GHz 50 ohms 2 to 50 W	Operating temperature range Operating relative humidity	-10°C to +65°C 95% Max.
---------	--	---	--	----------------------------

Note: The frequency range and the maximum input power will differ depending on the products.

Item	Standard	Conditions
1. Contact resistance	4 m ohms max.	1 A
2. Insulation resistance	1000 M ohms min.	100 V DC
3. Vibration	No electrical discontinuity of 1 μ s or more	Frequency of 10 to 2000 Hz, overall amplitude of 1.52 mm, acceleration of 98 m/s ² for 2 hours in each of 3 directions
4. Shock	No damage, cracks, or parts dislocation	Acceleration of 980 m/s ² , sine half-wave waveform, 3 cycles in each of the 3 axis
5. Temperature cycle	No damage, cracks, or parts dislocation	Temperature : -55°C → +5°C to +35°C → +85°C → +5°C to +35°C Time : 30 → 15 max. → 30 → 15 max. (Minutes) 200 cycles

● The test method conforms to MIL-STD-202.

■ Materials

Part	Material	Finish
Connector Body	Stainless steel	Passivated
Connector female contacts	Beryllium copper	Gold plating
Connector Insulator	PTFE	—
Case	Aluminum	—
Board	Dielectric	Gold plating

Ordering Information

HD H - 008 03 G H D
 ① ② ③ ④ ⑤ ⑥ ⑦

① Series Name: HD (Directional Couplers)	④ Coupling 03:3dB
② Type of Connector H: Indicates the HRM (SMA) Series	⑤ Frequency Relative Bandwidth B:From 5% to below 10% C:From 10% to below 15% D:From 15% to below 20% G:From 30% to below 35%
③ Center Frequency 008: 0.75GHz 015: 1.5GHz 017: 1.7GHz 020: 2.0GHz 030: 3.0GHz 040: 4.0GHz 060: 6.0GHz 090: 9.0GHz 128: 12.8GHz	
	⑥ Form H:H Type
	⑦ D:With Termination

Specifications

Part Number	Frequency Range (GHz)	Coupling (dB)	Frequency Sensitivity	Directivity (dB Min)	Primary Line V.S.W.R. (Max)	Secondary Line V.S.W.R. (Max)	Weight (g)	Power (W)
HDH-00803GHD	0.5~1.0	3 ^{+0.2}	±0.5	20	1.15	1.15	49	2
HDH-01503GH	1.0~2.0	3 ^{+0.2}	±0.5	20	1.20	1.20	34	50
HDH-01503GHD	1.0~2.0	3 ^{+0.2}	±0.5	20	1.20	1.20	34	2
HDH-01703CH	1.5~1.9	3 ^{+0.2}	±0.3	20	1.20	1.20	34	50
HDH-01703CHD	1.5~1.9	3 ^{+0.2}	±0.3	20	1.20	1.20	34	2
HDH-02003DHD	1.7~2.3	3 ^{+0.2}	±0.3	18	1.20	1.20	34	2
HDH-03003GHD	2.0~4.0	3 ^{+0.2}	±0.5	18	1.20	1.20	25	2
HDH-04003BH	3.7~4.2	3 ^{+0.2}	±0.3	20	1.20	1.20	23	50
HDH-06003GHD	4.0~7.8	3 ^{+0.3}	±0.5	17	1.25	1.25	23	2
HDH-09003GHD	8.0~11.0	3 ^{+0.3}	±0.5	15	1.30	1.30	31	2
HDH-12803CHD	10.5~14.5	3 ^{+0.6}	±0.5	12	1.40	1.40	31	2

- Directivity have had the coupling (nominal value of 3 dB) subtracted.
- There is a phase difference of 90° between the output and the coupling.

External Dimensions

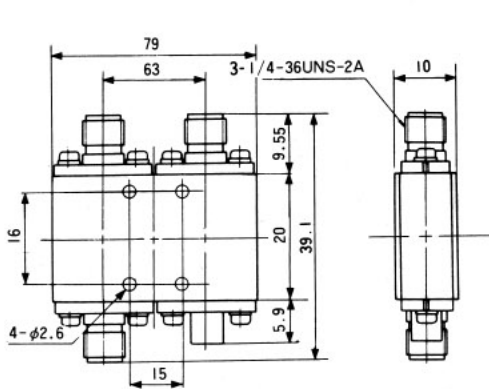

HDH-00803GHD

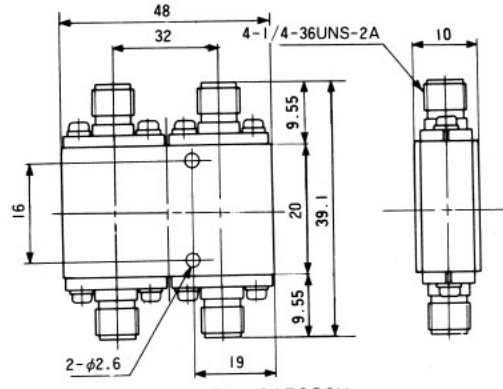

HDH-01503GH
HDH-01703CH

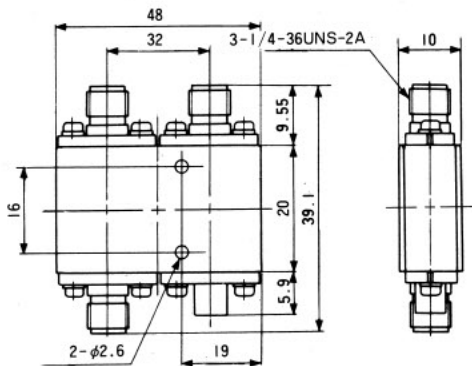

HDH-01503GHD
HDH-01703CHD
HDH-02003DHD

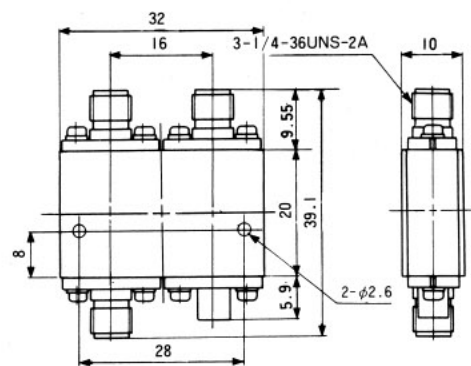

HDH-03003GHD

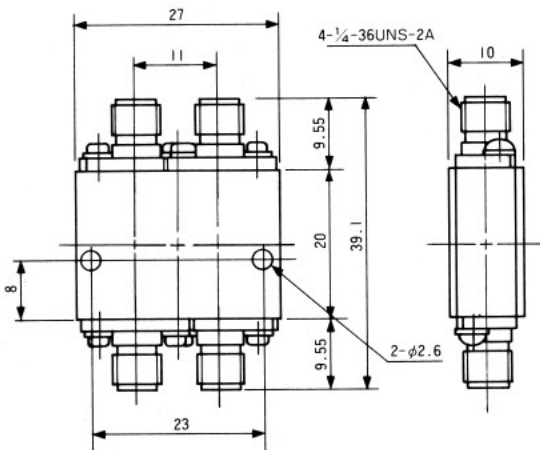

HDH-04003BH

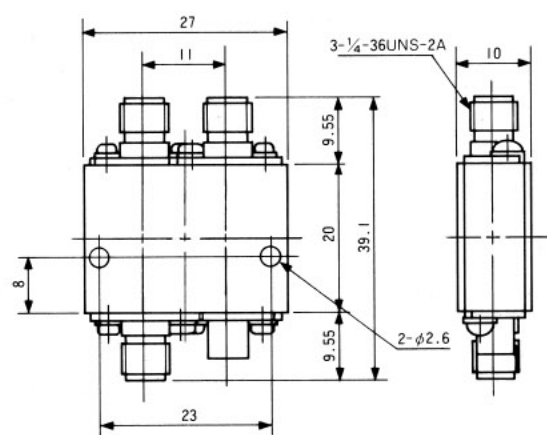

HDH-06003GHD

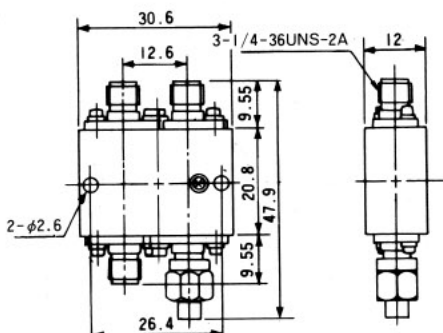

HDH-09003GHD

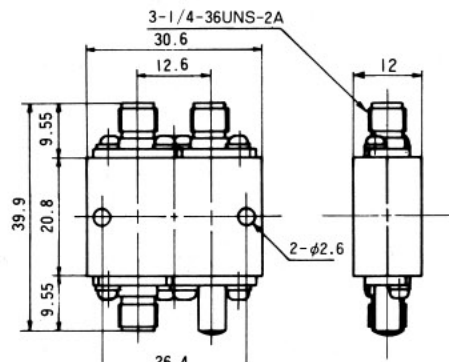

HDH-12803CHD

■ Typical Data

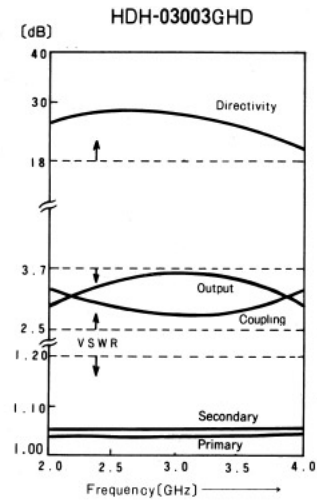
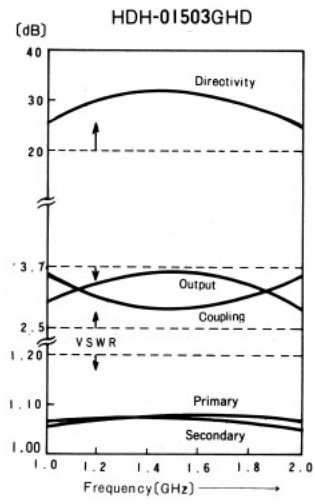

Couplers with Connectors (I Type)

HDH Series

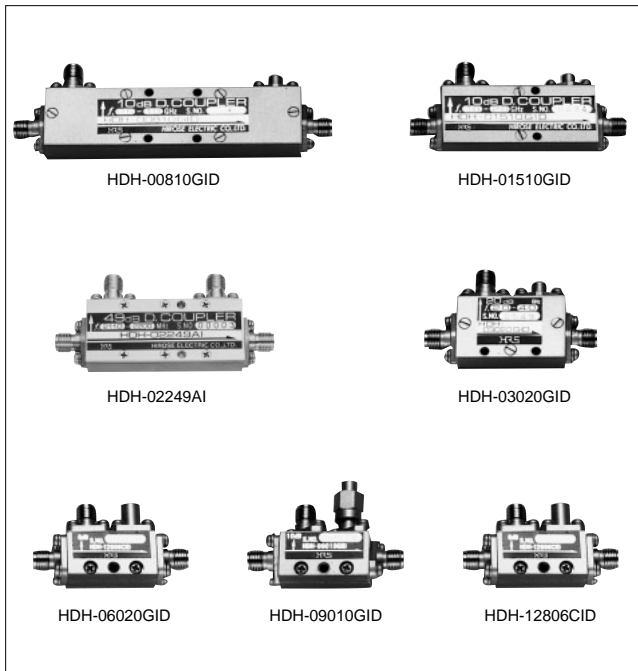

■ Features

1. High Performance

The high frequency characteristics feature. Extremely high degree of matching, and high isolation.

2. Miniature and Lightweight

Corrosion-resistant aluminum is used for the case and the Hirose Electric original pattern design, which uses a stripline triplate method, enables the couplers to be miniature and lightweight.

3. Couplers with SMA Connectors

Use of SMA connectors (Hirose Electric HRM Series) which feature stainless steel for the exterior cladding make these couplers durable.

4. Full Coupling Variations

Full variations of coupling over 6 dB are available.

■ Product Specifications

Ratings	Frequency range (Note) Characteristic impedance Maximum Input Power (Note)	0.5 to 14.5 GHz 50 ohms 4 to 50 W	Operating temperature range Operating relative humidity	-10°C to +65°C 95% Max.
---------	--	---	--	----------------------------

Note: The frequency range and the maximum input power will differ depending on the products.

Item	Standard	Conditions
1. Contact resistance	4 m ohms max.	1 A
2. Insulation resistance	1000 M ohms Max.	100 V DC
3. Vibration	No electrical discontinuity of 1 μ s or more	Frequency of 10 to 2000 Hz, overall amplitude of 1.52 mm, acceleration of 98 m/s ² for 2 hours in each of 3 directions
4. Shock	No damage, cracks, or parts dislocation	Acceleration of 980 m/s ² , sine half-wave waveform, 3 cycles in each of the 3 axis
5. Temperature cycle	No damage, cracks, or parts dislocation	Temperature : -55°C → +5°C to +35°C → +85°C → +5°C to +35°C Time : 30 → 15 max. → 30 → 15 max. (Minutes) 200 cycles

● The test method conforms to MIL-STD-202.

■ Materials

Part	Material	Finish
Connector Body	Stainless steel	Passivated
Connector female contacts	Beryllium copper	Gold plating
Connector Insulator	PTFE	-----
Case	Aluminum	-----
Board	Dielectric	Gold plating

Ordering Information

HD H - 008 10 G I D

① ② ③ ④ ⑤ ⑥ ⑦

① Series Name: HD (Directional Couplers)	④ Coupling 06 : 6dB 10 : 10dB 20 : 20dB 30 : 30dB 37 : 37dB 49 : 49dB
② Type of Connector H: Indicates the HRM (SMA) Series	
③ Center Frequency 008 : 0.8GHz 009 : 0.9GHz 015 : 1.5GHz 017 : 1.7GHz 022 : 2.2GHz 030 : 3.0GHz 060 : 6.0GHz 090 : 9.0GHz 128 : 12.8GHz	
⑤ Frequency Relative Bandwidth C: From 10% to below 15% G: From 30% to below 35%	
⑥ Form I: I Type, H: H Type	
⑦ D: With Termination Isolation port with termination is designated as D at the end of each part No.	

Specifications

Part Number	Frequency Range (GHz)	Coupling (dB)	Frequency Sensitivity (dB)	Insertion Loss (dB MAX)	Directivity (dB MIN)	Primary Line V.S.W.R. (MAX)	Secondary Line V.S.W.R. (MAX)	Weight (g)	Power (W)
HDH-00810GID	0.5~1.0	10±1.0	±0.75	0.3	20	1.15	1.15	49	10
HDH-00820GID	0.5~1.0	20±1.0	±0.75	0.3	18	1.15	1.15	50	50
HDH-00937CI	0.8~1.0	37±1.0	±0.5	0.3	20	1.20	1.20	50	50
HDH-01510GID	1.0~2.0	10±1.2	±0.75	0.4	20	1.20	1.20	34	10
HDH-01520GID	1.0~2.0	20±1.2	±0.75	0.4	18	1.20	1.20	34	50
HDH-01530CI	1.4~1.6	30 ^{+1.0} _{-2.0}	±0.25	0.5	20	1.20	1.20	34	50
HDH-01537CI	1.4~1.6	37 ^{+1.0} _{-1.5}	±0.3	0.5	20	1.20	1.20	34	50
HDH-01706CID	1.5~1.9	6±1.0	±0.3	0.4	18	1.20	1.20	34	5
HDH-01710CID	1.5~1.9	10±1.2	±0.3	0.4	20	1.20	1.20	34	10
HDH-01720CID	1.5~1.9	20±1.2	±0.4	0.4	20	1.20	1.20	34	50
HDH-01730CID	1.5~1.9	30±1.5	±0.4	0.4	18	1.20	1.20	34	50
HDH-02210AI	2.11~2.2	10±1.0	±0.25	0.8*	18	1.20	1.20	42	50
HDH-02220AID	2.11~2.2	20±1.0	±0.25	0.3	16	1.20	1.20	42	50
HDH-02249AI	2.11~2.2	49±1.0	±0.25	0.3	15	1.20	1.20	42	50
HDH-03010GID	2.0~4.0	10±1.2	±0.75	0.5	18	1.20	1.20	25	10
HDH-03020GID	2.0~4.0	20±1.2	±0.75	0.5	18	1.20	1.20	25	50
HDH-06010GID	4.0~7.8	10±1.2	±0.75	0.5	17	1.25	1.25	23	10
HDH-06020GID	4.0~7.8	20±1.2	±0.75	0.5	17	1.25	1.25	23	50
HDH-09006GID	8.0~11.0	6±1.2	±0.75	0.5	15	1.30	1.30	24	4
HDH-09010GID	8.0~11.0	10±1.2	±0.75	0.5	15	1.30	1.30	24	10
HDH-09020GID	8.0~11.0	20±2.0	±0.75	0.5	13	1.30	1.30	24	10
HDH-12806CID	10.5~14.5	6±1.0	±0.5	2.1*	15	1.30	1.35	28	4
HDH-12810CID	10.5~14.5	10±1.25	±0.5	1.1*	15	1.30	1.35	28	10
HDH-12820CID	10.5~14.5	20±1.25	±0.5	0.6	15	1.30	1.35	28	50

●The coupling loss component is not included in the insertion loss (unless the item is marked with an * symbol)

External Dimensions

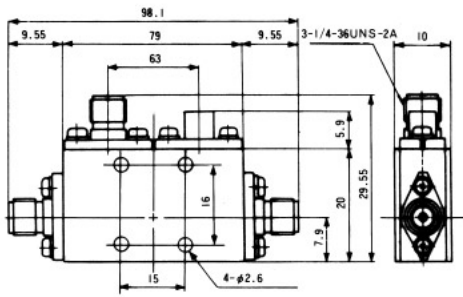

HDH-00810GID
HDH-00820GID

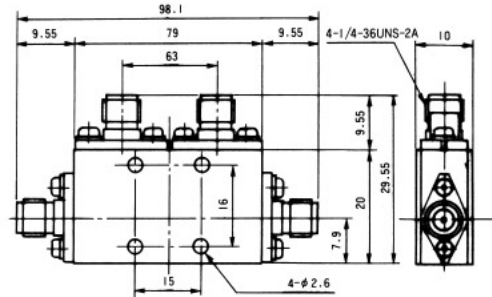

HDH-00937CI

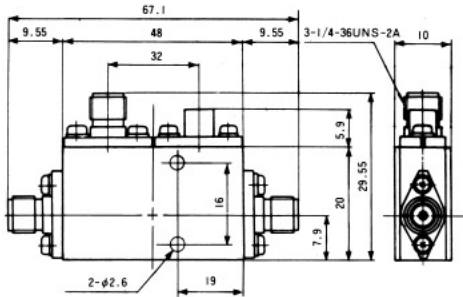

HDH-015¹⁰₂₀GID HDH-01710CID HDH-01730CID
HDH-01706CID HDH-01720CID

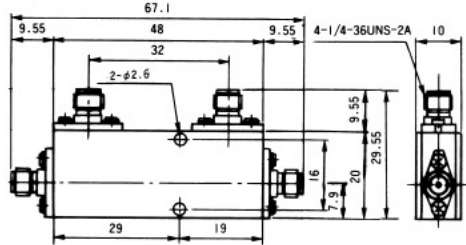

HDH-015³⁰₃₇

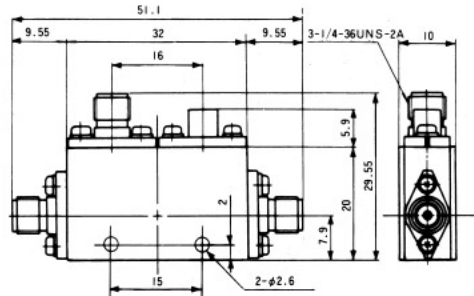

HDH-030¹⁰₂₀GID

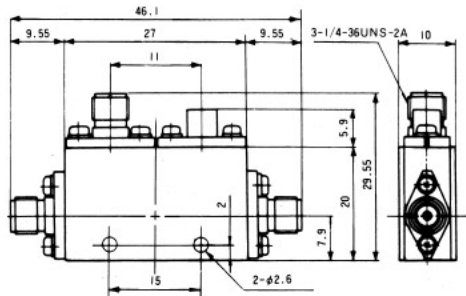

HDH-060¹⁰₂₀GID

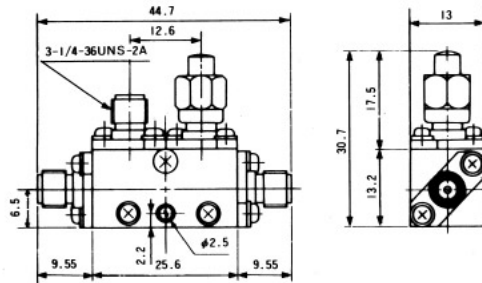

06
HDH-09010GID
20

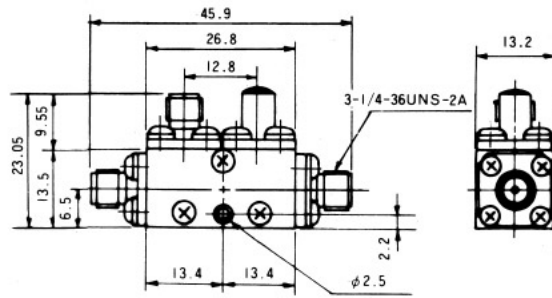

06
HDH-12810CID
20

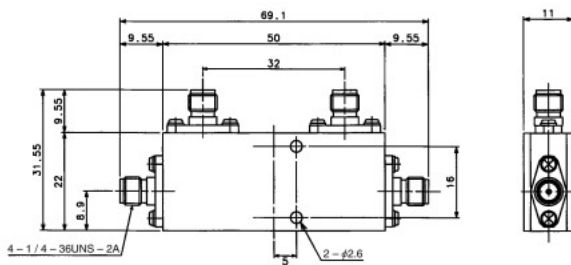

HDH-02210AI
HDH-02249AI

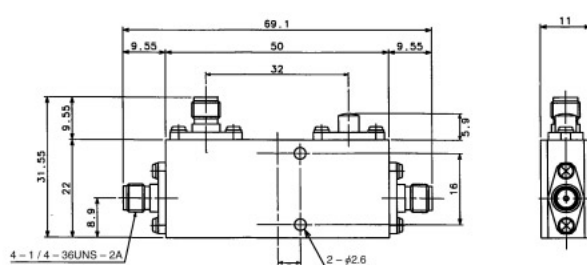

HDH-02220AID

Typical Data

