

# PBL 3771/1 Precision Stepper Motor Driver

## Description

The PBL 3771/1 is a switch-mode, constant-current driver IC (chopper) with two channels, one for each winding of a two-phase stepper motor. The circuit is especially developed for use in microstepping applications in conjunction with the matching dual DAC (Digital-to-Analog Converter) PBM 3960. A complete driver system consists of these two ICs, a few passive components and a microprocessor for generation of the proper control and data codes required for microstepping.

The PBL 3771/1 contains a clock oscillator, which is common for both driver channels; a set of comparators and flip-flops implementing the switching control; and two H-bridges with internal recirculation diodes. Voltage supply requirements are +5 V for logic and +10 to +45 V for the motor. Maximum output current is 650 mA per channel.

A special logic function is used to select slow or fast current decay in the output stage for improved high-speed microstepping.

The close match between the two driver channels guarantees consistent output current ratios and motor positioning accuracy.

## Key Features

- Dual chopper driver in a single package.
- 650 mA output current per channel.
- Close matching between channels for high microstepping accuracy.
- Selectable slow/fast current decay for improved high-speed microstepping.
- Improved low-level linearity.
- Specially matched to Dual DAC PBM 3960.
- Selection of packages, 22-pin "batwing" DIP, 24 pin "batwing" SOIC or 28-lead PLCC with lead-frame for heat-sinking through PC board copper.

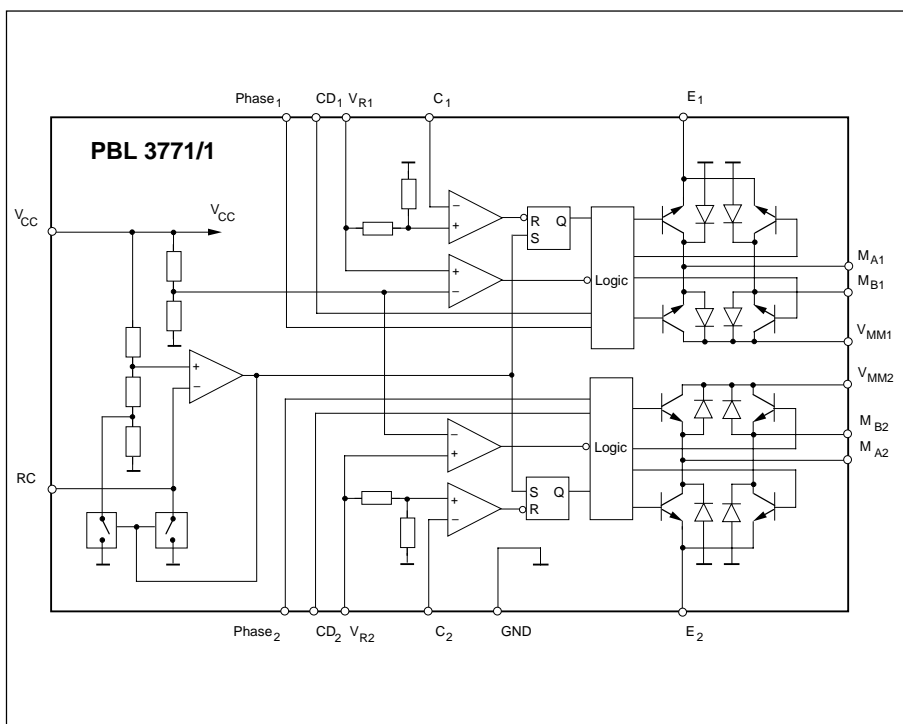
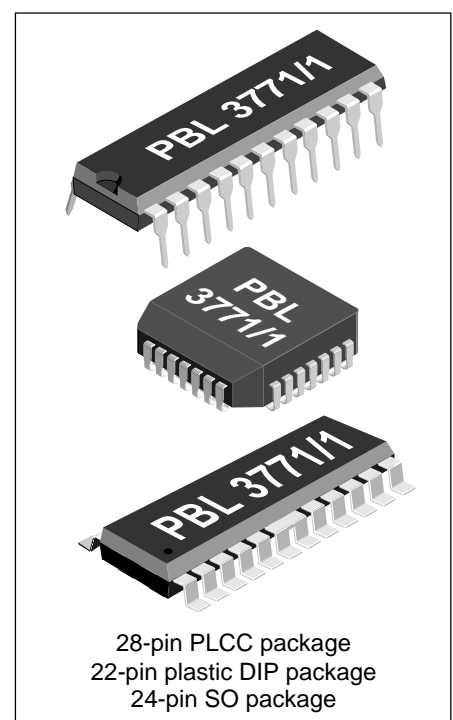

Figure 1. Block diagram.



### Maximum Ratings

Parameter	Pin no. (DIL)	Symbol	Min	Max	Unit
<b>Voltage</b>					
Logic supply	11	$V_{CC}$	0	7	V
Motor supply	3, 20	$V_{MM}$	0	45	V
Logic inputs	7, 8, 15, 16	$V_I$	-0.3	6	V
Comparator inputs	10, 13	$V_C$	-0.3	$V_{CC}$	V
Reference inputs	9, 14	$V_R$	-0.3	7.5	V
<b>Current</b>					
Motor output current	1, 4, 19, 22	$I_M$	-700	+700	mA
Logic inputs	7, 8, 15, 16	$I_I$	-10		mA
Analog inputs	10, 13	$I_A$	-10		mA
Oscillator charging current	12	$I_{RC}$		5	mA
<b>Temperature</b>					
Operating junction temperature		$T_J$	-40	+150	°C
Storage temperature**		$T_S$	-55	+150	°C

\*\* Circuit only. The packaging can handle max 60°C

### Recommended Operating Conditions

Parameter	Symbol	Min	Typ	Max	Unit
Logic supply voltage	$V_{CC}$	4.75	5	5.25	V
Motor supply voltage	$V_{MM}$	10		40	V
Motor output current ***	$I_M$	-650		650	mA
Junction temperature ****	$T_J$	-20		+125	°C
Rise time logic inputs	$t_r$			2	µs
Fall time logic inputs	$t_f$			2	µs
Oscillator timing resistor	$R_T$	2	15	20	kohms

\*\*\* In microstepping mode, "sine/cosine" drive where  $I_1 = 650 \cdot \cos(\theta)$  and  $I_2 = 650 \cdot \sin(\theta)$  mA, otherwise 500 mA/channel both channels fully on.

\*\*\*\* See operating temperature chapter.

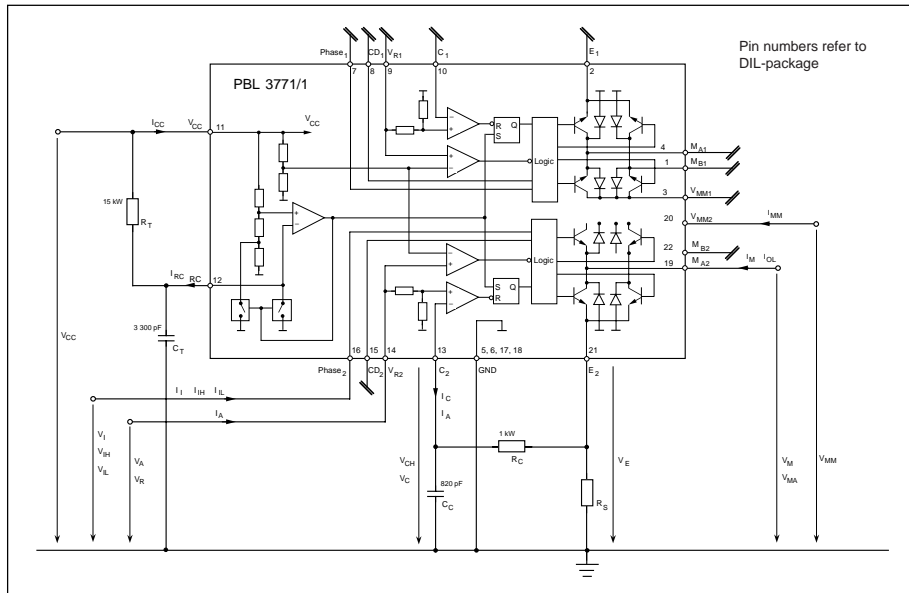

Figure 2. Definitions of symbols.

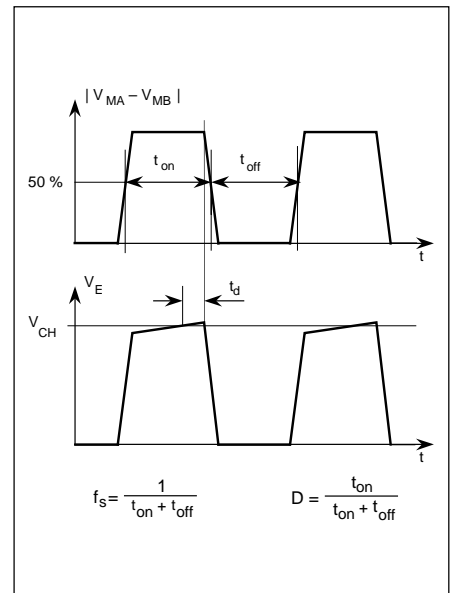

Figure 3. Definition of terms.

## Electrical Characteristics

Electrical characteristics over recommended operating conditions, unless otherwise noted. -20°C - T<sub>J</sub> - +125°C.

Parameter	Symbol	Ref. fig.	Conditions	Min	Typ	Max	Unit
<b>General</b>							
Supply current	I <sub>CC</sub>				38	50	mA
Total power dissipation	P <sub>D</sub>		V <sub>MM</sub> = 40 V, I <sub>M1</sub> = 450 mA, I <sub>M2</sub> = 0 mA. Notes 2, 3.		1.4	1.6	W
			V <sub>MM</sub> = 40 V, I <sub>M1</sub> = I <sub>M2</sub> = 318 mA. Notes 2, 3.		1.6	1.8	W
Turn-off delay	t <sub>d</sub>	3	T <sub>a</sub> = +25°C, dV <sub>C</sub> /dt ≥ 50 mV/μs. Note 3.		1.0	1.5	μs
<b>Logic Inputs</b>							
Logic HIGH input voltage	V <sub>IH</sub>			2.0			V
Logic LOW input voltage	V <sub>IL</sub>					0.8	V
Logic HIGH input current	I <sub>IH</sub>		V <sub>I</sub> = 2.4 V			20	μA
Logic LOW input current	I <sub>IL</sub>		V <sub>I</sub> = 0.4 V	-0.4			mA
<b>Reference Inputs</b>							
Input resistance	R <sub>R</sub>		T <sub>a</sub> = +25°C		5		kohms
Input current	I <sub>R</sub>		T <sub>a</sub> = +25°C, V <sub>R</sub> = 2.5 V.		0.5	1.0	mA
Turn-off voltage	V <sub>TO</sub>			20	29	38	mV
<b>Comparator Inputs</b>							
Threshold voltage	V <sub>CH</sub>		R <sub>C</sub> = 1 kohms, V <sub>R</sub> = 2.5 V	430	450	470	mV
V <sub>CH1</sub> - V <sub>CH2</sub>   mismatch	V <sub>CH,diff</sub>		R <sub>C</sub> = 1 kohms		1		mV
Input current	I <sub>C</sub>			-10		1	μA
<b>Motor Outputs</b>							
Lower transistor saturation voltage			I <sub>M</sub> = 500 mA		1.00	1.20	V
Lower transistor leakage current			V <sub>MM</sub> = 41 V, V <sub>E</sub> = V <sub>R</sub> = 0 V, V <sub>C</sub> = V <sub>CC</sub>			300	μA
Lower diode forward voltage drop			I <sub>M</sub> = 500 mA		1.10	1.25	V
Upper transistor saturation voltage			I <sub>M</sub> = 500 mA		1.20	1.35	V
Upper transistor leakage current			V <sub>MM</sub> = 41 V, V <sub>E</sub> = V <sub>R</sub> = 0 V, V <sub>C</sub> = V <sub>CC</sub>			300	μA
Upper diode forward voltage drop			I <sub>M</sub> = 500 mA		1.00	1.25	V
<b>Chopper Oscillator</b>							
Chopping frequency	f <sub>s</sub>	3	C <sub>T</sub> = 3300 pF, R <sub>T</sub> = 15 kohms	25.0	26.5	28.0	kHz

## Thermal Characteristics

Parameter	Symbol	Ref. fig.	Conditions	Min	Typ	Max	Unit
Thermal resistance	R <sub>th,J-BW</sub>	13	DIL package.		11		°C/W
	R <sub>th,J-A</sub>	13	DIL package. Note 2.		40		°C/W
	R <sub>th,J-BW</sub>	13	PLCC package.		9		°C/W
	R <sub>th,J-A</sub>	13	PLCC package. Note 2.		35		°C/W
	R <sub>th,J-BW</sub>	13	SO package.		13		°C/W
	R <sub>th,J-A</sub>	13	SO package. Note 2.		42		°C/W

### Notes

- All voltages are with respect to ground. Currents are positive into, negative out of specified terminal.
- All ground pins soldered onto a 20 cm<sup>2</sup> PCB copper area with free air convection.
- Not covered by final test program.
- Switching duty cycle D = 30%, f<sub>s</sub> = 26.5 kHz.

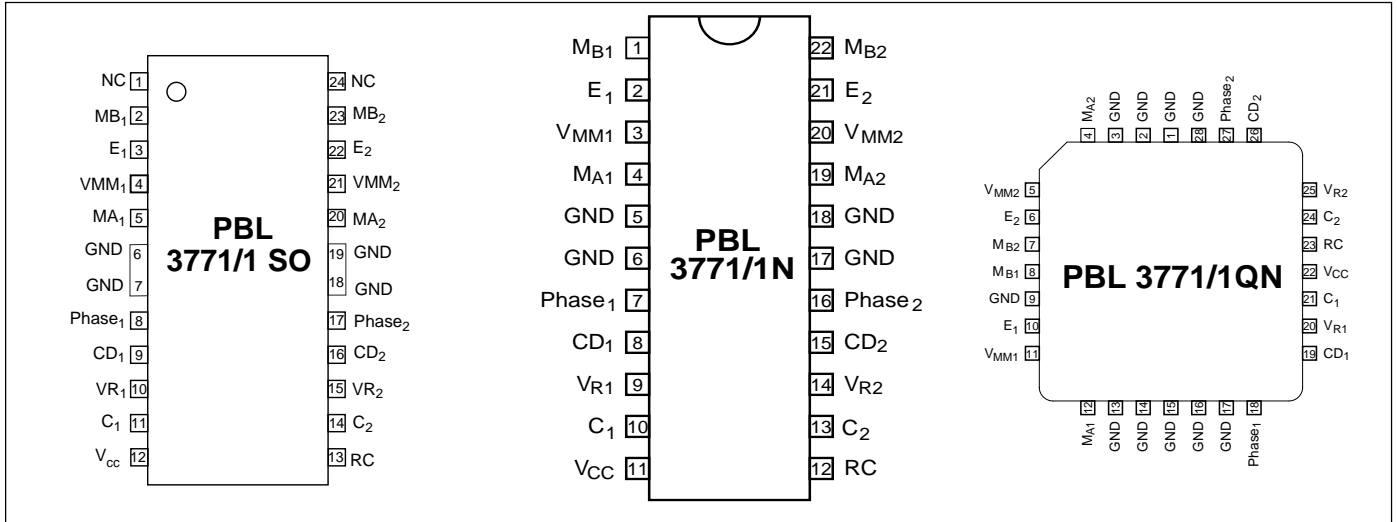

Figure 4. Pin configuration.

### Pin Description

Refer to figure 4.

SO	DIP	PLCC	Symbol	Description
2	1	8	$M_{B1}$	Motor output B, channel 1. Motor current flows from $M_{A1}$ to $M_{B1}$ when Phase <sub>1</sub> is HIGH.
3	2	10	$E_1$	Common emitter, channel 1. This pin connects to a sensing resistor to ground.
4	3	11	$V_{MM1}$	Motor supply voltage, channel 1, 10 to 40 V. $V_{MM1}$ and $V_{MM2}$ should be connected together.
5	4	12	$M_{A1}$	Motor output A, channel 1. Motor current flows from $M_{A1}$ to $M_{B1}$ when Phase <sub>1</sub> is HIGH.
6,7, 18,19	5,6, 17,18	1-3,9, 13-17,28	GND	Ground and negative supply. Note: these pins are used thermally for heat-sinking. Make sure that all ground pins are soldered onto a suitably large copper ground plane for efficient heat sinking.
8	7	18	Phase <sub>1</sub>	Controls the direction of motor current at outputs $M_{A1}$ and $M_{B1}$ . Motor current flows from $M_{A1}$ to $M_{B1}$ when Phase <sub>1</sub> is HIGH.
9	8	19	CD <sub>1</sub>	Current decay control, channel 1. A logic HIGH on this input results in <i>slow</i> current decay, a LOW results in <i>fast</i> current decay, see "Functional Description."
10	9	20	$V_{R1}$	Reference voltage, channel 1. Controls the threshold voltage for the comparator and hence the output current. Input resistance is typically 2.5 kohms, $\pm 20\%$ .
11	10	21	$C_1$	Comparator input channel 1. This input senses the instantaneous voltage across the sensing resistor, filtered by an RC network. The threshold voltage for the comparator is $(0.450 / 2.5) \cdot V_{R1}$ , i.e. 450 mV at $V_{R1} = 2.5$ V.
12	11	22	$V_{CC}$	Logic voltage supply, nominally +5 V.
13	12	23	RC	Clock oscillator RC pin. Connect a 15 kohm resistor to $V_{CC}$ and a 3300 pF capacitor to ground to obtain the nominal switching frequency of 26.5 kHz.
14	13	24	$C_2$	Comparator input channel 2. This input senses the instantaneous voltage across the sensing resistor, filtered by an RC network. The threshold voltage for the comparator is $(0.450 / 2.5) \cdot V_{R1}$ , i.e. 450 mV at $V_{R1} = 2.5$ V.
15	14	25	$V_{R2}$	Reference voltage, channel 2. Controls the threshold voltage for the comparator and hence the output current. Input resistance is typically 2.5 kohms, $\pm 20\%$ .
16	15	26	CD <sub>2</sub>	Current decay control, channel 2. A logic HIGH on this input results in <i>slow</i> current decay, a LOW results in <i>fast</i> current decay, see "Functional Description."
17	16	27	Phase <sub>2</sub>	Controls the direction of motor current at outputs $M_{A2}$ and $M_{B2}$ . Motor current flows from $M_{A2}$ to $M_{B2}$ when Phase <sub>2</sub> is HIGH.
20	19	4	$M_{A2}$	Motor output A, channel 2. Motor current flows from $M_{A2}$ to $M_{B2}$ when Phase <sub>2</sub> is HIGH.
21	20	5	$V_{MM2}$	Motor supply voltage, channel 2, 10 to 40 V. $V_{MM1}$ and $V_{MM2}$ should be connected together.
22	21	6	$E_2$	Common emitter, channel 2. This pin connects to a sensing resistor to ground.
23	22	7	$M_{B2}$	Motor output B, channel 2. Motor current flows from $M_{A2}$ to $M_{B2}$ when Phase <sub>2</sub> is HIGH.

**Functional Description**

Each channel of the PBL 3771/1 consists of the following sections: an H-bridge output stage, capable of driving up to 650 mA continuous motor current (or 500 mA, both channels driven), a logic section that controls the output transistors, an S-R flip-flop, and two comparators. The oscillator is common to both channels.

Constant current control is achieved by switching the current to the windings. This is done by sensing the (peak) voltage across a current-sensing resistor,  $R_S$ , effectively connected in series with the motor winding, and feeding that voltage back to a comparator. When the motor current reaches a threshold level, determined by the voltage at the reference input,  $V_R$ , the comparator resets the flip-flop, which turns off the output transistors. The current decreases until the clock oscillator triggers the flip-flop, which turns on the output transistors again, and the cycle is repeated.

The current-decay rate during the turn-off portion of the switching cycle, can be selected fast or slow by the CD input.

In slow current-decay mode, only one of the lower transistors in the H-bridge (those closest to the negative supply) is switched on and off, while one of the upper transistors is held constantly on. During turn-off, the current recirculates through the upper transistor (which one depends on current direction) and the corresponding free-wheeling diode connected to  $V_{MM}$ ; see figure 5.

In fast current decay mode, both the upper and lower transistors are switched. During the off-time, the freewheeling current is opposed by the supply voltage, causing a rapid discharge of energy in the winding.

Fast current decay may be required in half- and microstepping applications when rapid changes of motor current are necessary. Slow current decay, however, gives less current ripple, and should always be selected, if possible, to mini-mize core losses and switching noise.

**Applications Information**

**Current control**

The output current to the motor winding is mainly determined by the voltage at the reference input and the value of the sensing resistor,  $R_S$ .

Chopping frequency, winding inductance, and supply voltage will affect the current level, but to much less extent. Fast current decay setting will produce somewhat lower (average) current than slow current decay. The peak current through the sensing resistor (and motor winding) can be expressed as:

$$I_{M,peak} = 0.18 \cdot (V_R / R_S) \quad [A]$$

i.e., with a recommended value of 1 ohm for the sensing resistor,  $R_S$ , a 2.5 V reference voltage will produce an output current of approximately 450 mA. To improve noise immunity on the  $V_R$  input, the control range may be increased to 5 volts if  $R_S$  is correspondingly changed to 2 ohms.

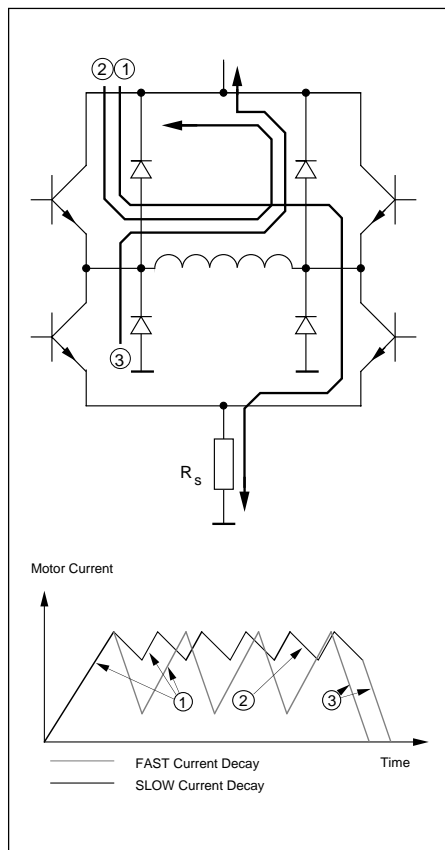

Figure 5. Output stage with current paths during turn-on, turn-off and phase shift.

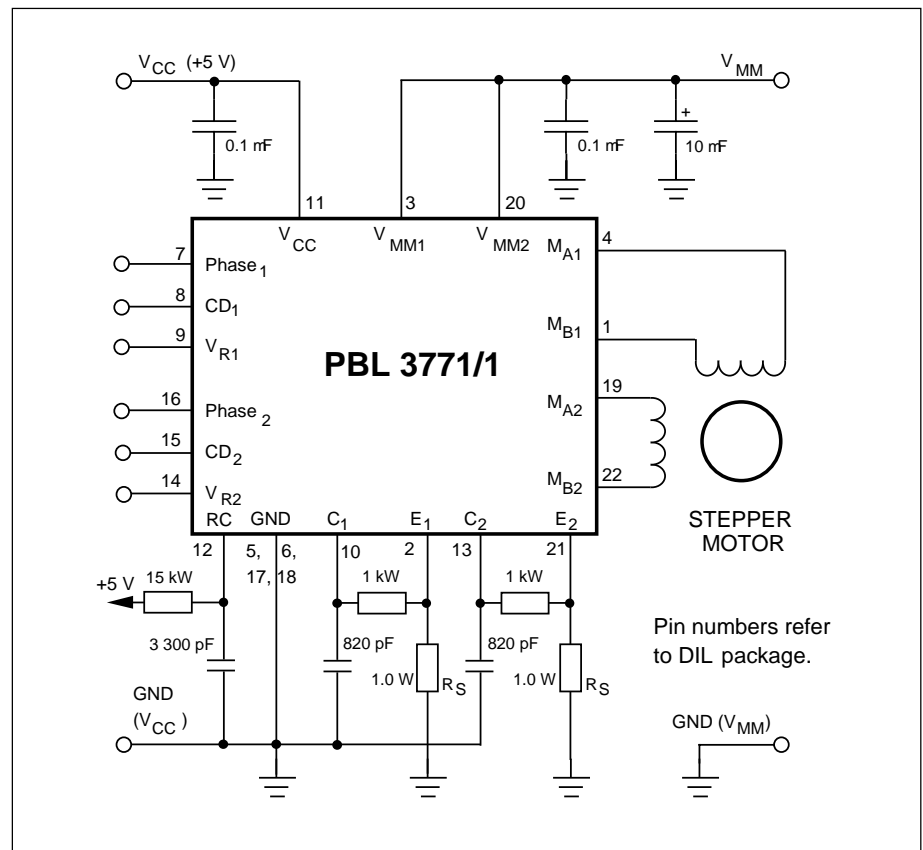

Figure 6. Typical stepper motor application with PBL 3771/1.

**External components**

The voltage across the sensing resistor is fed back to the comparator via a low-pass filter section, to prevent erroneous switching due to switching transients. The recommended filter component values, 1 kohm and 820 pF, are suitable for a wide range of motors and operational conditions.

Since the low-pass filtering action introduces a small delay of the signal to the comparator, peak voltage across the sensing resistor, and hence the peak motor current, will reach a slightly higher level than the threshold,  $V_C$ , set by the reference voltage ( $V_C = 450 \text{ mV} @ V_R = 2.5 \text{ V}$ ).

The time constant of the low-pass filter may therefore be reduced to minimize the delay and optimize low-current performance, especially if a low (12 V) supply voltage is used. Increasing the time constant may result in unstable switching.

The frequency of the clock oscillator is set by the R-C combination at pin RC. The recommended values give a nominal frequency of 26.5 kHz. A lower

frequency will result in higher current ripple and may cause audible noise from the motor, while increasing the frequency results in higher switching losses and possibly increased iron losses in the motor.

The sensing resistor,  $R_S$ , should be selected for maximum motor current. The relationship between peak motor current, reference voltage and the value of  $R_S$  is described under "Current control" above. Be sure not to exceed the maximum output current which is 650 mA per channel (or 500 mA per channel, both channels fully on, see "Recommended Operating Conditions").

**Motor selection**

The PBL 3771/1 is designed for bipolar motors, i.e., motors that have only one winding per phase. A unipolar motor, having windings with a center tap, can also be used, see figure 14.

The chopping principle in the PBL 3771/1 is based on a constant frequency and a varying duty cycle. This scheme imposes certain restrictions on motor selection. Unstable chopping can

occur if the chopping duty cycle exceeds approximately 50%. To avoid this, it is necessary to choose a motor with a low winding resistance. Low winding resistance means less inductance and will therefore enable higher stepping rates, however it also means less torque capability. A compromise has to be made.

Choose a motor with the lowest possible winding resistance that still gives the required torque and use as high supply voltage as possible without exceeding the maximum recommended 40 V. Check that the chopping duty cycle does not exceed 50% at maximum current.

Since the PBL 3771/1 produces a regulated, constant output current it is not necessary to use a motor that is rated at the same voltage as the actual supply voltage. Only rated current needs to be considered. Typical motors to be used together with the PBL 3771/1 have voltage ratings of 5 to 12 V, while the supply voltage usually ranges from 24 to 40 V.

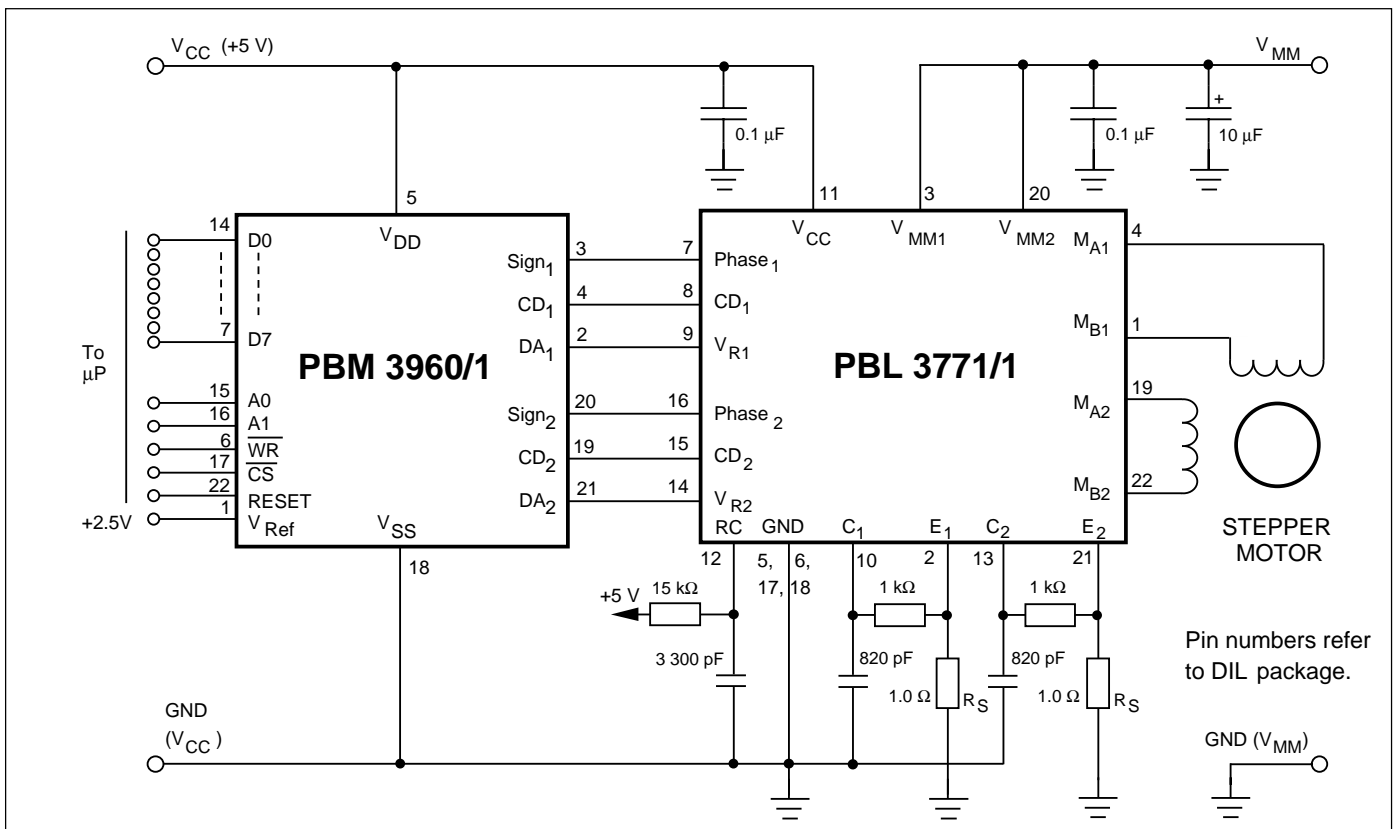

Figure 7. Microstepping system with PBM 3960 /1 and PBL 3771/1.

**General**

**Phase inputs.** A logic HIGH on a Phase input gives positive current flowing out from  $M_A$  into  $M_B$ . A logic LOW gives a current in the opposite direction.

**Slow/fast current decay.** A logic HIGH on the CD input gives slow current decay, a logic LOW gives fast current decay.

**Heat sinking.** Soldering the four center pins onto a free PCB copper area of 20 cm<sup>2</sup> (approx. 1.8" x 1.8", copper foil thickness = 35 μm) permits the circuit to operate with a maximum of 320 mA output current, both channels driving, at ambient temperatures up to +70°C. Consult figures 12 and 13 in order to determine the necessary copper area for heat sinking if higher currents are required.

**Thermal shutdown.** The circuit is equipped with a thermal shutdown function that reduces the output current at chip temperatures above +160°C.

**Operating temperature.** The max recommended operating temperature is 125°C. This gives an estimated lifelength of about 5 years at continuous drive, A change of ±10° would increase/decrease the lifelength of the circuit with about 5 years.

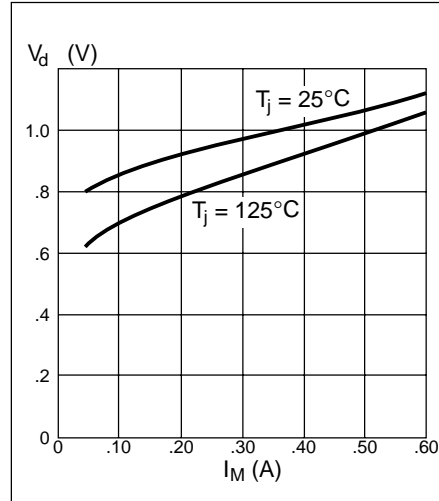

Figure 8. Typical upper diode voltage drop vs. recirculating current.

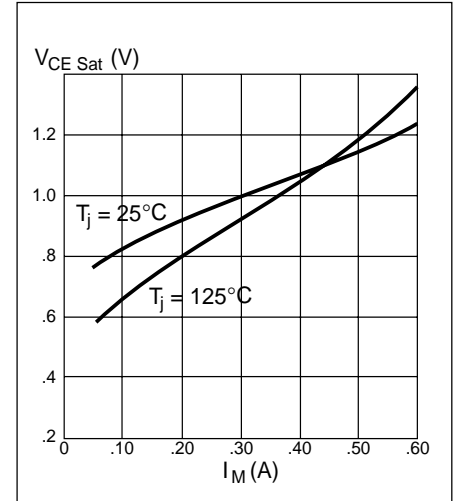

Figure 9. Typical source saturation voltage vs. output current.

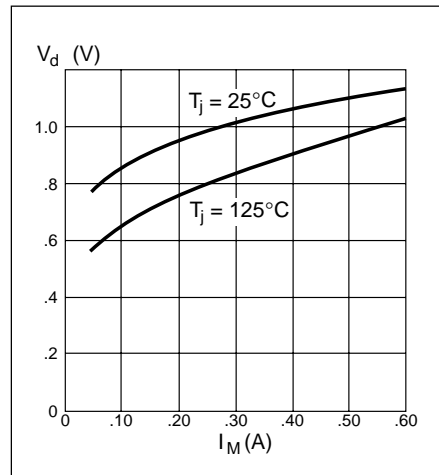

Figure 10. Typical lower diode voltage drop vs. recirculating current.

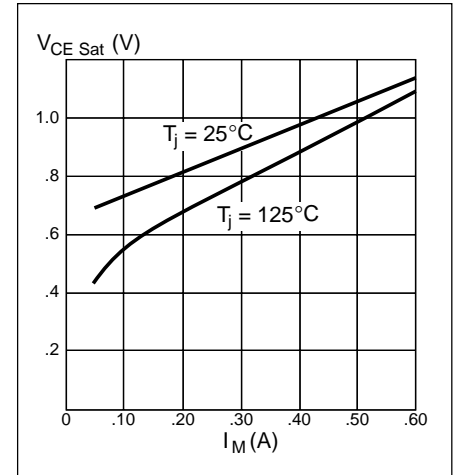

Figure 11 Typical sink saturation voltage vs. output current.

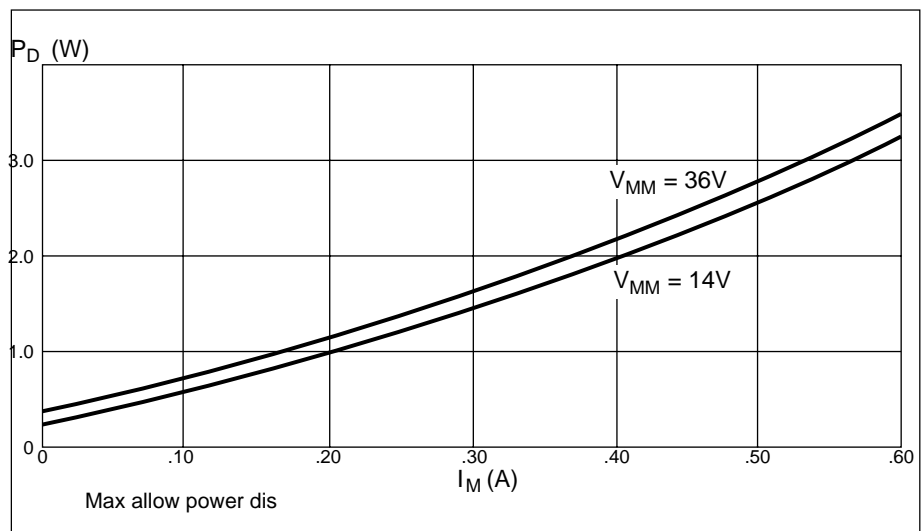

Figure 12. Power dissipation vs. motor current, both channels driven,  $T_a = 25^\circ\text{C}$ .

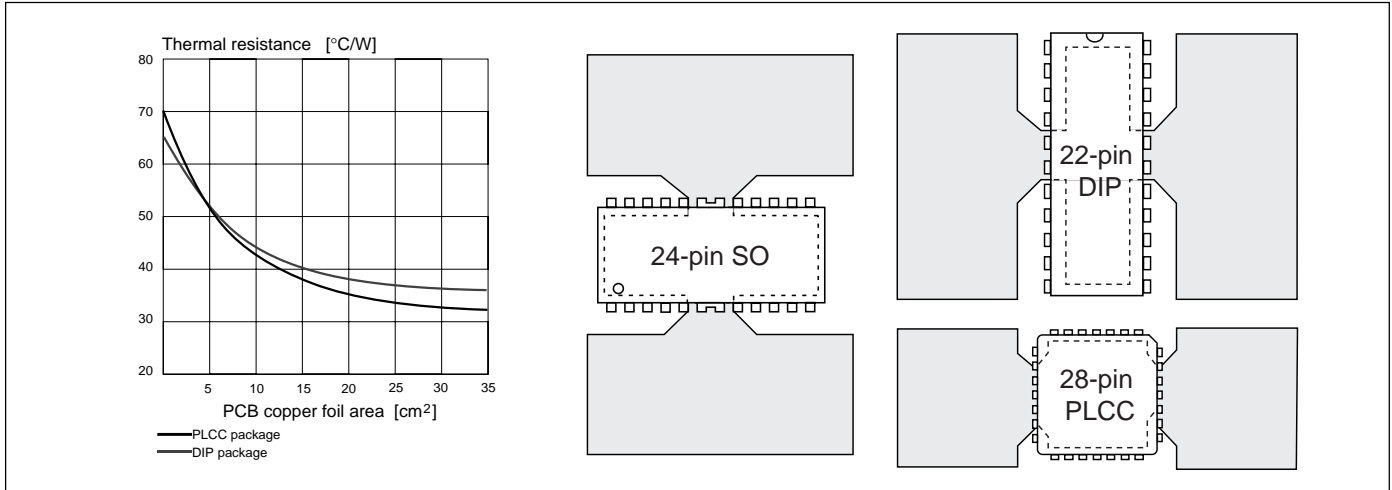

Figure 13. Thermal Resistance vs. PC Board copper area and suggested layout.

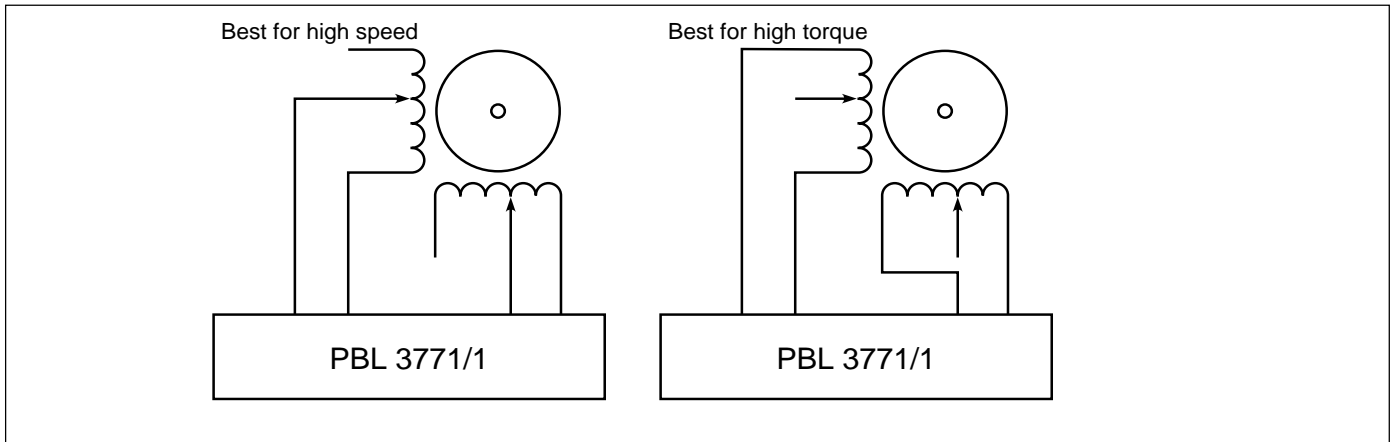

Figure 14. Connection of unipolar motors.

Information given in this data sheet is believed to be accurate and reliable. However no responsibility is assumed for the consequences of its use nor for any infringement of patents or other rights of third parties which may result from its use. No license is granted by implication or otherwise under any patent or patent rights of Ericsson Components. These products are sold only according to Ericsson Components' general conditions of sale, unless otherwise confirmed in writing.

### Ordering Information

Package	Part No.
DIP Tube	PBL 3771/1NS
PLCC Tube	PBL 3771/1QNS
PLCC Tape & Reel	PBL 3771/1QNT
SO tube	PBL 3771/1SOS
SO Tape & Reel	PBL 3771/1SOT

Specifications subject to change without notice.

1522-PBL 3771/1 Uen. Rev B  
© Ericsson Components AB 1999