

XC6367/6368 Series



PWM Controlled, PWM/PFM Switchable Step - Up DC/DC Controllers

- ◆ **Input Voltage Range** : 0.9~10.0V
- ◆ **Output Voltage Range** : 1.5~6.5V(±2.5%)
- ◆ **Oscillator Frequency** : 300kHz(±15%)
- ◆ **PWM/PFM Switching Control (XC6368)**
- ◆ **High Efficiency** : 84% (typ.)
- ◆ **SOT-25 Package**

Applications

- Electronic Information Organizers
- Palmtops
- Cellular and portable phones
- Portable Audio Systems
- Various Multi-function Power Supplies

General Description

The XC6367/68 series are multi-functional step-up DC/DC converter controllers with built-in high speed, low ON resistance drivers.

Large output currents are possible using an externally connected transistor, coil, diode and condenser.

Output voltage is selectable in 0.1 steps within a 1.5V ~ 6.5V range (±2.5%). For output voltages outside this range, we recommend this FB version, which has a 1.0V internal reference voltage. Using this version, the required output voltage can be set-up using 2 external resistors.

With a 300kHz switching frequency, the size of the external components can be reduced.

Control switches from PWM to PFM during light loads with the XC6368 (PWM/PFM switchable) and the series is highly efficient from light loads to large output currents.

Soft start time of XC6367/68A, B, and C series is internally set to 10msec and XC6367/68C, D, and F series regulate soft start time by connecting resistors and capacitors externally.

During stand-by time (CE pin "Low"), current consumption is reduced to less than 0.5µA.

Features

- Input voltage range** : 0.9V~10V
- Operating voltage range** : 2.0V~10V
- Output voltage range** : 1.5V~6.5V programmable in 0.1V steps (±2.5%)
- Oscillator frequency** : 300, 100kHz (±15%)
Custom products for 180, 500kHz
- Output Current** : 200mA + (VIN=1.8V, VOUT=3.3V)
- High Efficiency** : 84% (typ.)
- Stand-by capability** : I_{STB}=0.5A (max.)
- Selection** : Soft start set-up external
Output Voltage set-up internal (V_{OUT})
Output Voltage set-up external (FB)
- Package** : SOT-25

4

Typical Application Circuit

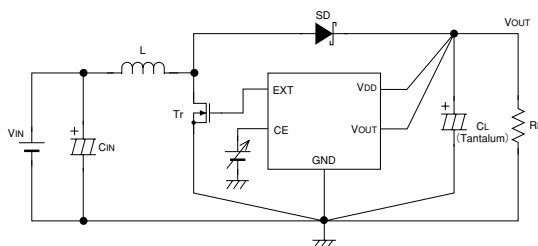

Typical Performance Characteristic

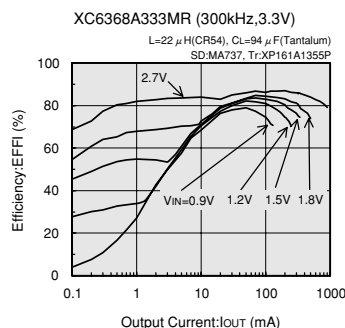

XC6367/6368 Series

Pin Configuration

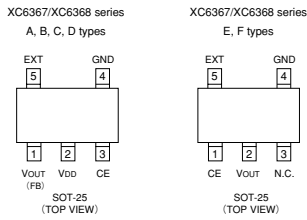

Pin Assignment

PIN NUMBER		PIN NAME	FUNCTION
XC6367 / XC6368	A, B, C, D		
5	5	EXT	External transistor connection
2	-	V _{DD}	Supply voltage input
4	4	GND	Ground
3	1	CE	Chip Enable (C, D, F types : soft start set-up external, soft start capacitor connected)
1	2	V _{OUT} (FB)	Output voltage monitor (E, F types : output voltage monitor, power supply) (B, D types : output voltage set-up external)

4

Product Classification

Selection Guide

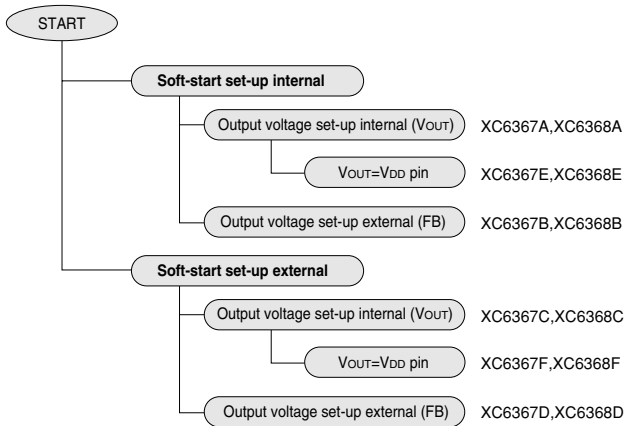

XC6367/6368
Series

● Ordering Information

XC6367①②③④⑤⑥

SYMBOL		V _{OUT} /FB	SOFT-START
①	A	V _{OUT}	Set-up Internal
	B	FB	Set-up Internal
	C	V _{OUT}	Set-up External
	D	FB	Set-up External
	E	V _{OUT}	Set-up Internal
	F	V _{OUT}	Set-up External
②	Output voltage value : e.g. 3.0V output : (②=3, ③=0),		
③	F.B. products (B,D types) : (②=1, ③=0)		
④	3	Oscillator Frequency 300kHz	
	1	Oscillator Frequency 100kHz	
	2	Oscillator Frequency 180kHz (Custom)	
	5	Oscillator Frequency 500kHz (Custom)	
⑤	M	Package SOT-25	
⑥	R	Embossed Tape : Standard Feed	
	L	: Reverse Feed	

4

XC6368①②③④⑤⑥

XC6368 Series PWM/PFM switching control (same as XC6367 series)

■ Packaging Information

● SOT-25

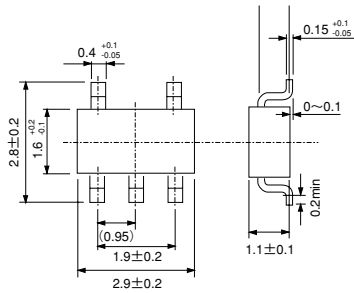

XC6367/6368 Series

■ Marking

●XC6367 Series

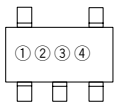

SOT-25
(TOP VIEW)

① Represents the Product Classification

PRODUCT NAME	DESIGNATOR
XC6367A	A
XC6367B	B
XC6367C	C
XC6367D	D
XC6367E	E
XC6367F	F

② Represents the integer of the Output Voltage and Oscillator Frequency

INTEGER OF THE OUTPUT VOLTAGE	OSCILLATOR FREQUENCY (kHz)			
	100	180	300	500
1	B	1	1	B
2	C	2	2	C
3	D	3	3	D
4	E	4	4	E
5	F	5	5	F
6	H	6	6	H

③ Represents the decimal number of the Output Voltage and Oscillator Frequency

THE DECIMAL NUMBER OF OUTPUT VOLTAGE	OSCILLATOR FREQUENCY (kHz)			
	100	180	300	500
0	0	0	A	A
1	1	1	B	B
2	2	2	C	C
3	3	3	D	D
4	4	4	E	E
5	5	5	F	F
6	6	6	H	H
7	7	7	K	K
8	8	8	L	L
9	9	9	M	M

④ Denotes the production lot number
0 to 9, A to Z repeated(G,I,J,O,Q,W excepted)

XC6367/6368
Series

●XC6368 Series

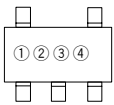

SOT-25
(TOP VIEW)

① Represents the Product Classification

PRODUCT NAME	DESIGNATOR
XC6368A	K
XC6368B	L
XC6368C	M
XC6368D	N
XC6368E	P
XC6368F	R

② Represents the integer of the Output Voltage and Oscillator Frequency

INTEGER OF THE OUTPUT VOLTAGE	OSCILLATOR FREQUENCY (kHz)			
	100	180	300	500
1	B	1	1	B
2	C	2	2	C
3	D	3	3	D
4	E	4	4	E
5	F	5	5	F
6	H	6	6	H
CUSTOM	S			

4

③ Represents the decimal number of the Output Voltage and Oscillator Frequency

THE DECIMAL NUMBER OF OUTPUT VOLTAGE	OSCILLATOR FREQUENCY (kHz)			
	100	180	300	500
0	0	0	A	A
1	1	1	B	B
2	2	2	C	C
3	3	3	D	D
4	4	4	E	E
5	5	5	F	F
6	6	6	H	H
7	7	7	K	K
8	8	8	L	L
9	9	9	M	M

④ Denotes the production lot number
0 to 9, A to Z repeated(G.I.J.O.Q.W excepted)

XC6367/6368 Series

Block Diagram

XC6367, XC6368 Series A, C, E, F types (V_{OUT})

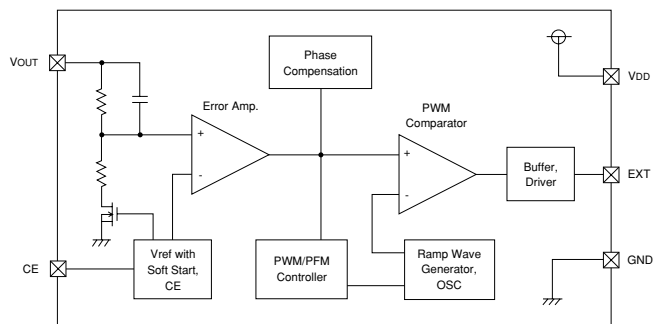

Note : Connecting V_{OUT} and V_{DD} internally with E, F types.

XC6367, XC6368 Series B,D types (FB)

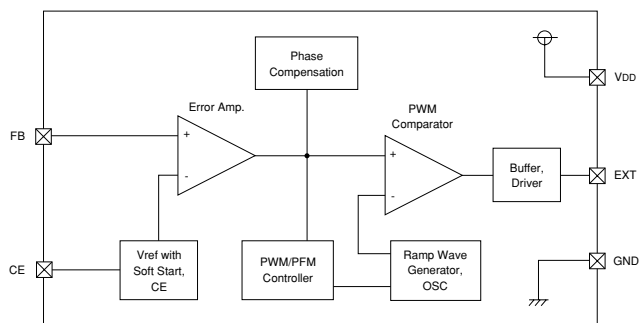

Absolute Maximum Ratings

Ta=25°C

PARAMETER	SYMBOL	RATINGS	UNITS
V _{DD} Pin Voltage	V _{DD}	-0.3 ~ 12	V
V _{OUT} Pin Voltage	V _{OUT}	-0.3 ~ 12	V
FB Pin Voltage	V _{FB}	-0.3 ~ 12	V
CE Pin Voltage	V _{CE}	-0.3 ~ 12	V
EXT Pin Voltage	V _{EXT}	-0.3 ~ V _{DD} +0.3	V
EXT Pin Current	I _{EXT}	±100	mA
Continuous Total Power Dissipation	P _d	150	mW
Operating Ambient Temperature	T _{opr}	-30 ~ +80	°C
Storage Temperature	T _{stg}	-40 ~ +125	°C

4

Electrical Characteristics

XC6367A333MR, XC6368A333MR

(V_{OUT}=3.3V, F_{OSC}=300kHz)

Ta=25°C

PARAMETER	SYMBOL	CONDITIONS	MIN	TYP	MAX	UNITS
Output Voltage	V _{OUT}		3.218	3.300	3.383	V
Supply Voltage (Note 1)	V _{DD}		2.0	-	10.0	V
Maximum Input Voltage	V _{IN}		10.0	-	-	V
Oscillation Start-up Voltage 1	V _{ST1}	Use of a 2SD1628 transistor, I _{OUT} =1.0mA	-	-	0.9	V
Oscillation Start-up Voltage 2	V _{ST2}	V _{OUT} =CE : Apply voltage	-	-	0.8	V
Oscillation Hold Voltage	V _{HLD}	Use of a 2SX1628 transistor recommended, I _{OUT} =1.0mA	-	-	0.7	V
Supply Current 1	I _{DD1}	V _{OUT} =CE=set-up output voltage x 0.95	-	130	200	μA
Supply Current 2	I _{DD2}	V _{OUT} =CE=set-up output voltage + 0.5V	-	20	35	μA
Stand-by Current	I _{STB}	V _{OUT} =set-up output voltage x 0.95, CE=0V	-	-	0.5	μA
Oscillator Frequency	F _{OSC}	Same as I _{DD1}	255	300	345	kHz
Maximum Duty Ratio	MAXDTY	Same as I _{DD1}	78	85	92	%
PFM Duty Ratio (Note 3)	PFMDTY	I _{OUT} =0mA	15	25	35	%
CE "High" Voltage	V _{CEH}	V _{OUT} =set-up output voltage x0.95	0.65	-	-	V
CE "Low" Voltage	V _{CEL}	V _{OUT} =set-up output voltage x0.95	-	-	0.20	V
EXT "High" ON Resistance	R _{EXTH}	Same as I _{DD1} , V _{EXT} =V _{OUT} -0.4V	-	29	43	Ω
EXT "Low" ON Resistance	R _{EXTL}	Same as I _{DD1} , V _{EXT} =0.4V	-	19	27	Ω
Efficiency (Note 2)	EFFI		-	84	-	%
Soft-Start Time	T _{SS}		5	10	20	msec

Measuring conditions: Unless otherwise specified, connect V_{DD} to V_{OUT}; V_{IN}=set-up output voltage x 0.6, I_{OUT}=130mA

Note 1: When taking V_{DD} from another power source please ensure that V_{DD} = 2.0V or more.
Oscillation will occur with a value of V_{DD} = 0.8V or more, but with a value of V_{DD} = 2.0V or more, output voltage and oscillation frequency will be stable.

Note 2: EFFI = ((output voltage) x (output current)) ÷ ((input voltage) x (input current)) x 100

Note 3: Applies to the XC6368 series only (duty ratio when control changes to PFM).

XC6367/6368 Series

XC6367A503MR, XC6368A503MR (V_{OUT}=5.0V, F_{OSC}=300kHz) Ta=25°C

PARAMETER	SYMBOL	CONDITIONS	MIN	TYP	MAX	UNITS
Output Voltage	V _{OUT}		4.875	5.000	5.125	V
Supply Voltage (Note 1)	V _{DD}		2.0	-	10.0	V
Maximum Input Voltage	V _{IN}		10.0	-	-	V
Oscillation Start-up Voltage 1	V _{ST1}	Use of a 2SD1628 transistor, I _{OUT} =1.0mA	-	-	0.9	V
Oscillation Start-up Voltage 2	V _{ST2}	V _{OUT} =CE : Apply voltage	-	-	0.8	V
Oscillation Hold Voltage	V _{HLD}	Use of a 2SD1628 transistor, I _{OUT} =1.0mA	-	-	0.7	V
Supply Current 1	I _{DD1}	V _{OUT} =CE=set-up output voltage x 0.95	-	180	280	μA
Supply Current 2	I _{DD2}	V _{OUT} =CE=set-up output voltage + 0.5V	-	22	38	μA
Stand-by Current	I _{STB}	V _{OUT} =set-up output voltage x 0.95, CE=0V	-	-	0.5	μA
Oscillator Frequency	F _{OSC}	Same as I _{DD1}	255	300	345	kHz
Maximum Duty Ratio	MAXDTY	Same as I _{DD1}	78	85	92	%
PFM Duty Ratio (Note 3)	PFMDTY	I _{OUT} =0mA	15	25	35	%
CE "High" Voltage	V _{CEH}	V _{OUT} =set-up output voltage x0.95	0.65	-	-	V
CE "Low" Voltage	V _{CEL}	V _{OUT} =set-up output voltage x0.95	-	-	0.20	V
EXT "High" ON Resistance	R _{EXTH}	Same as I _{DD1} , V _{EXT} =V _{OUT} -0.4V	-	20	29	Ω
EXT "Low" ON Resistance	R _{EXTL}	Same as I _{DD1} , V _{EXT} =0.4V	-	13	19	Ω
Efficiency (Note 2)	EFFI		-	87	-	%
Soft-Start Time	T _{SS}		5	10	20	msec

Measuring conditions: Unless otherwise specified, connect V_{DD} to V_{OUT}; V_{IN}=set-up output voltage x 0.6, I_{OUT}=200mA

Note 1: When taking V_{DD} from another power source please ensure that V_{DD} = 2.0V or more. Oscillation will occur with a value of V_{DD} = 0.8V or more, but with a value of V_{DD} = 2.0V or more, output voltage and oscillation frequency will be stable.

Note 2: $EFFI = \frac{[(\text{output voltage}) \times (\text{output current})]}{[(\text{input voltage}) \times (\text{input current})]} \times 100$

Note 3: Applies to the XC6368 series only (duty ratio when control changes to PFM).

Series Amendments:

XC6367C, XC6368C series

Please note that the following condition applies:
Soft Start Time (T_{SS}): Connect R_{SS}, C_{SS}. CE 0V → 3.0V

XC6367E, XC6368E series

Please delete 'Supply Voltage (V_{DD})' and '(Note 1)'
Please add the following note:

Note 4: There are no products within the XC6367E, XC6368E series range which have a set-up voltage of less than 2.0V.

XC6367F, XC6368F series

Please note that the following condition applies:
Soft Start Time (T_{SS}): Connect R_{SS}, C_{SS}. CE 0V → 3.0V

Please delete 'Supply Voltage (V_{DD})' and '(Note 1)'
Please add the following note:

Note 4: There are no products within the XC6367F, XC6368F series range which have a set-up voltage of less than 2.0V.

XC6367/6368
Series

XC6367B103MR, XC6368B103MR $V_{OUT}=3.0V$ (when set-up), $F_{OSC}=300kHz$ $T_a=25^{\circ}C$

PARAMETER	SYMBOL	CONDITIONS	MIN	TYP	MAX	UNITS
Output Voltage	V_{OUT}		2.925	3.000	3.075	V
Supply Voltage (Note 1)	V_{DD}		2.0	-	10.0	V
Maximum Input Voltage	V_{IN}		10.0	-	-	V
Oscillation Start-up Voltage 1	V_{ST1}	Use of a 2SD1628 transistor, $I_{OUT}=1.0mA$	-	-	0.9	V
Oscillation Start-up Voltage 2	V_{ST2}	$V_{DD}=CE$: Apply voltage, $FB=0V$	-	-	0.8	V
Oscillation Hold Voltage	V_{HLD}	Use of a 2SD1628 transistor, $I_{OUT}=1.0mA$	-	-	0.7	V
Supply Current 1	I_{DD1}	$V_{DD}=CE=2.85V$, $FB=0V$	-	120	190	μA
Supply Current 2	I_{DD2}	$V_{DD}=CE=3.5V$, $FB=1.2V$	-	20	34	μA
Stand-by Current	I_{STB}	$V_{DD}=2.85V$, $CE=0V$, $FB=0V$	-	-	0.5	μA
Oscillator Frequency	F_{OSC}	Same as I_{DD1}	255	300	345	kHz
Maximum Duty Ratio	MAXDTY	Same as I_{DD1}	78	85	92	%
PFM Duty Ratio (Note 3)	PFMDTY	$I_{OUT}=0mA$	15	25	35	%
CE "High" Voltage	V_{CEH}	$V_{DD}=2.85V$, $FB=0V$	0.65	-	-	V
CE "Low" Voltage	V_{CEL}	$V_{DD}=2.85V$, $FB=0V$	-	-	0.20	V
EXT "High" ON Resistance	R_{EXTH}	Same as I_{DD1} , $V_{EXT}=V_{OUT}-0.4V$	-	32	47	Ω
EXT "Low" ON Resistance	R_{EXTL}	Same as I_{DD1} , $V_{EXT}=0.4V$	-	20	30	Ω
Efficiency (Note 2)	EFFI		-	84	-	%
Soft-Start Time	T_{SS}		5	10	20	msec

Measuring conditions: Unless otherwise specified, $V_{IN}=1.8V$, $I_{OUT}=120mA$
External components : $R_{FB1} = 400k\Omega$, $R_{FB2} = 200k\Omega$, $C_{FB} = 47pF$

Note 1: When taking V_{DD} from another power source please ensure that $V_{DD} = 2.0V$ or more.
Oscillation will occur with a value of $V_{DD} = 0.8V$ or more, but with a value of $V_{DD} = 2.0V$ or more,
output voltage and oscillation frequency will be stable.

Note 2: $EFFI = \frac{((output\ voltage) \times (output\ current))}{((input\ voltage) \times (input\ current))} \times 100$

Note 3: Applies to the XC6368 series only (duty ratio when control changes to PFM).

Series Amendments:

XC6367D, XC6368D series

Please note that the following condition applies :

Soft Start Time (T_{SS}) : Connect R_{SS} , C_{SS} . $CE\ 0V \rightarrow 3.0V$

4

XC6367/6368 Series

XC6367A331MR, XC6368A331MR (V_{OUT}=3.3V, F_{OSC}=100kHz) Ta=25°C

PARAMETER	SYMBOL	CONDITIONS	MIN	TYP	MAX	UNITS
Output Voltage	V _{OUT}		3.218	3.300	3.383	V
Supply Voltage (Note 1)	V _{DD}		2.0	–	10.0	V
Maximum Input Voltage	V _{IN}		10.0	–	–	V
Oscillation Start-up Voltage 1	V _{ST1}	Use of a 2SD1628 transistor, I _{OUT} =1.0mA	–	–	0.9	V
Oscillation Start-up Voltage 2	V _{ST2}	V _{OUT} =CE : Apply voltage	–	–	0.8	V
Oscillation Hold Voltage	V _{HLD}	Use of a 2SD1628 transistor, I _{OUT} =1.0mA	–	–	0.7	V
Supply Current 1	I _{DD1}	V _{OUT} =CE=set-up output voltage x 0.95	–	50	100	μA
Supply Current 2	I _{DD2}	V _{OUT} =CE=set-up output voltage + 0.5V	–	11	20	μA
Stand-by Current	I _{STB}	V _{OUT} =set-up output voltage x 0.95, CE=0V	–	–	0.5	μA
Oscillator Frequency	F _{OSC}	Same as I _{DD1}	85	100	115	kHz
Maximum Duty Ratio	MAXDTY	Same as I _{DD1}	78	85	92	%
PFM Duty Ratio (Note 3)	PFMDTY	I _{OUT} =0mA	15	25	35	%
CE "High" Voltage	V _{CEH}	V _{OUT} =set-up output voltage x0.95	0.65	–	–	V
CE "Low" Voltage	V _{CEL}	V _{OUT} =set-up output voltage x0.95	–	–	0.20	V
EXT "High" ON Resistance	R _{EXTH}	Same as I _{DD1} , V _{EXT} =V _{OUT} -0.4V	–	29	43	Ω
EXT "Low" ON Resistance	R _{EXTL}	Same as I _{DD1} , V _{EXT} =0.4V	–	19	27	Ω
Efficiency (Note 2)	EFFI		–	84	–	%
Soft-Start Time	T _{SS}		5	10	20	msec

Measuring conditions: Unless otherwise specified, connect V_{DD} to V_{OUT}; V_{IN}=set-up output voltage x 0.6, I_{OUT}=130mA

Note 1: When taking V_{DD} from another power source please ensure that V_{DD} = 2.0V or more.
Oscillation will occur with a value of V_{DD} = 0.8V or more, but with a value of V_{DD} = 2.0V or more, output voltage and oscillation frequency will be stable.

Note 2: $EFFI = \frac{[(\text{output voltage}) \times (\text{output current})]}{[(\text{input voltage}) \times (\text{input current})]} \times 100$

Note 3: Applies to the XC6368 series only (duty ratio when control changes to PFM).

4

XC6367/6368
Series

XC6367A501MR, XC6368A501MR (V_{OUT}=5.0V, F_{OSC}=100kHz) Ta=25°C

PARAMETER	SYMBOL	CONDITIONS	MIN	TYP	MAX	UNITS
Output Voltage	V _{OUT}		4.875	5.000	5.125	V
Supply Voltage (Note 1)	V _{DD}		2.0	–	10.0	V
Maximum Input Voltage	V _{IN}		10.0	–	–	V
Oscillation Start-up Voltage 1	V _{ST1}	Use of a 2SD1628 transistor, I _{OUT} =1.0mA	–	–	0.9	V
Oscillation Start-up Voltage 2	V _{ST2}	V _{OUT} =CE : Apply voltage	–	–	0.8	V
Oscillation Hold Voltage	V _{HLD}	Use of a 2SD1628 transistor, I _{OUT} =1.0mA	–	–	0.7	V
Supply Current 1	I _{DD1}	V _{OUT} =CE=set-up output voltage x 0.95	–	70	120	μA
Supply Current 2	I _{DD2}	V _{OUT} =CE=set-up output voltage + 0.5V	–	11	22	μA
Stand-by Current	I _{STB}	V _{OUT} =set-up output voltage x 0.95, CE=0V	–	–	0.5	μA
Oscillator Frequency	F _{OSC}	Same as I _{DD1}	85	100	115	kHz
Maximum Duty Ratio	MAXD _{TY}	Same as I _{DD1}	78	85	92	%
PFM Duty Ratio (Note 3)	PFMD _{TY}	I _{OUT} =0mA	15	25	35	%
CE "High" Voltage	V _{CEH}	V _{OUT} =set-up output voltage x0.95	0.65	–	–	V
CE "Low" Voltage	V _{CEL}	V _{OUT} =set-up output voltage x0.95	–	–	0.20	V
EXT "High" ON Resistance	R _{EXTH}	Same as I _{DD1} , V _{EXT} =V _{OUT} -0.4V	–	20	29	Ω
EXT "Low" ON Resistance	R _{EXTL}	Same as I _{DD1} , V _{EXT} =0.4V	–	13	19	Ω
Efficiency (Note 2)	EFFI		–	87	–	%
Soft-Start Time	T _{SS}		5	10	20	msec

Measuring conditions: Unless otherwise specified, connect V_{DD} to V_{OUT}; V_{IN}=set-up output voltage x 0.6, I_{OUT}=200mA

Note 1: When taking V_{DD} from another power source please ensure that V_{DD} = 2.0V or more.
Oscillation will occur with a value of V_{DD} = 0.8V or more, but with a value of V_{DD} = 2.0V or more, output voltage and oscillation frequency will be stable.

Note 2: EFFI = ((output voltage) x (output current)) + ((input voltage) x (input current)) x 100

Note 3: Applies to the XC6368 series only (duty ratio when control changes to PFM).

4

XC6367/6368 Series

XC6367B101MR, XC6368B101MR $V_{OUT}=3.0V$ (when set-up), $F_{OSC}=100kHz$ $T_a=25^{\circ}C$

PARAMETER	SYMBOL	CONDITIONS	MIN	TYP	MAX	UNITS
Output Voltage	V_{OUT}		2.925	3.000	3.075	V
Supply Voltage (Note 1)	V_{DD}		2.0	-	10.0	V
Maximum Input Voltage	V_{IN}		10.0	-	-	V
Oscillation Start-up Voltage 1	V_{ST1}	Use of a 2SD1628 transistor, $I_{OUT}=1.0mA$	-	-	0.9	V
Oscillation Start-up Voltage 2	V_{ST2}	$V_{DD}=CE$: Apply voltage, $FB=0V$	-	-	0.8	V
Oscillation Hold Voltage	V_{HLD}	Use of a 2SD1628 transistor, $I_{OUT}=1.0mA$	-	-	0.7	V
Supply Current 1	I_{DD1}	$V_{DD}=CE=2.85V$, $FB=0V$	-	50	90	μA
Supply Current 2	I_{DD2}	$V_{DD}=CE=3.5V$, $FB=1.2V$	-	11	20	μA
Stand-by Current	I_{STB}	$V_{DD}=2.85V$, $CE=0V$, $FB=0V$	-	-	0.5	μA
Oscillator Frequency	F_{OSC}	Same as I_{DD1}	85	100	115	kHz
Maximum Duty Ratio	MAXDTY	Same as I_{DD1}	78	85	92	%
PFM Duty Ratio (Note 3)	PFMDTY	$I_{OUT}=0mA$	15	25	35	%
CE "High" Voltage	V_{CEH}	$V_{DD}=2.85V$, $FB=0V$	0.65	-	-	V
CE "Low" Voltage	V_{CEL}	$V_{DD}=2.85V$, $FB=0V$	-	-	0.20	V
EXT "High" ON Resistance	R_{EXTH}	Same as I_{DD1} , $V_{EXT}=V_{OUT}-0.4V$	-	32	47	Ω
EXT "Low" ON Resistance	R_{EXTL}	Same as I_{DD1} , $V_{EXT}=0.4V$	-	20	30	Ω
Efficiency (Note 2)	EFFI		-	84	-	%
Soft-Start Time	T_{SS}		5	10	20	msec

Measuring conditions: Unless otherwise specified, $V_{IN}=1.8V$, $I_{OUT}=120mA$
External components: $R_{FB1} = 400k\Omega$, $R_{FB2} = 200k\Omega$, $C_{FB} = 47pF$

Note 1: When taking V_{DD} from another power source please ensure that $V_{DD} = 2.0V$ or more.
Oscillation will occur with a value of $V_{DD} = 0.8V$ or more, but with a value of $V_{DD} = 2.0V$ or more, output voltage and oscillation frequency will be stable.

Note 2: $EFFI = \frac{((\text{output voltage}) \times (\text{output current}))}{((\text{input voltage}) \times (\text{input current}))} \times 100$

Note 3: Applies to the XC6368 series only (duty ratio when control changes to PFM).

4

■ Typical Application Circuits

Circuit 1. XC6367A, XC6368A

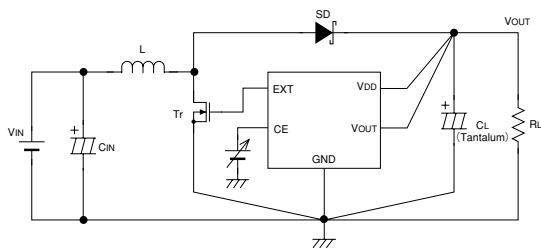

Circuit 2. XC6367B, XC6368B

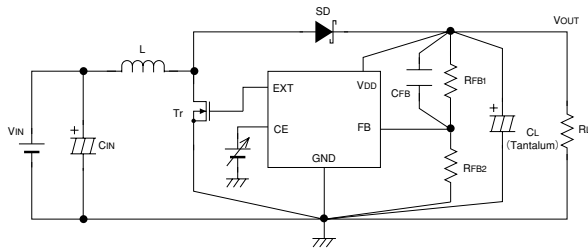

Circuit 3. XC6367C, XC6368C

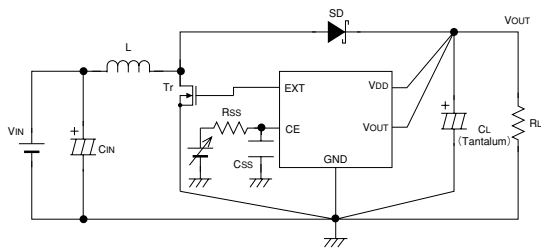

4

XC6367/6368 Series

Circuit 4. XC6367D, XC6368D

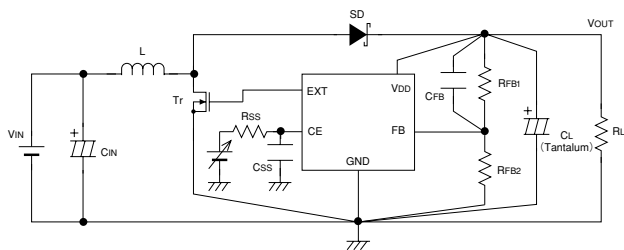

4

Circuit 5. XC6367E, XC6368E

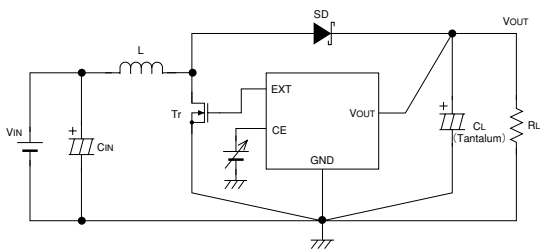

Circuit 6. XC6367F, XC6368F

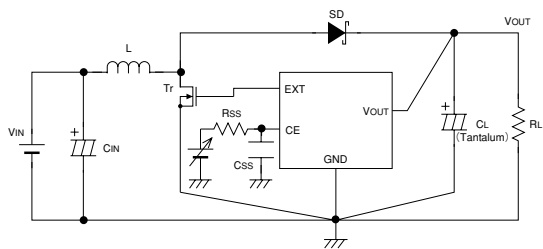

Circuit 7. XC6367A, XC6368A (NPN Transistor)

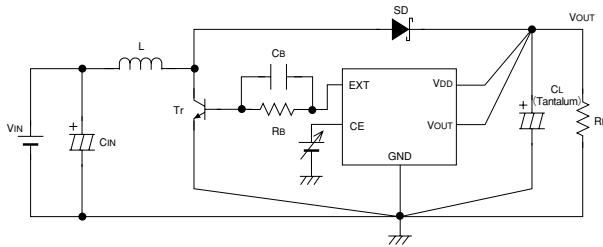

Circuit 8. XC6367B, XC6368B (NPN Transistor)

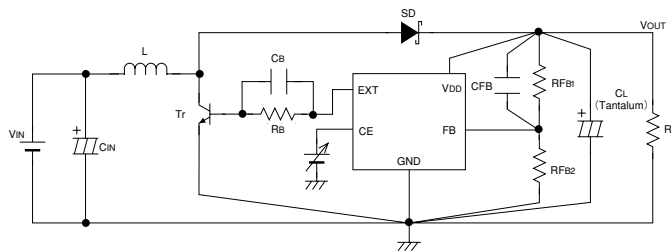

Circuit 9. XC6367C, XC6368C (NPN Transistor)

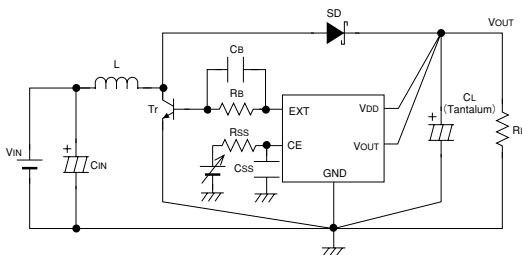

4

XC6367/6368 Series

Circuit 10. XC6367D, XC6368D (NPN Transistor)

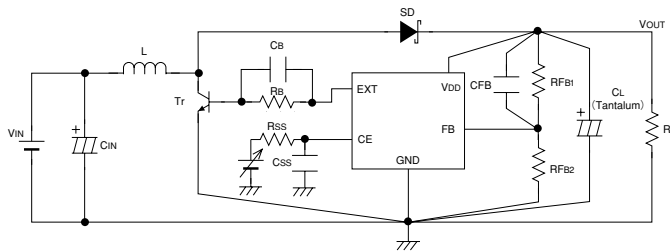

4

Circuit 11. XC6367E, XC6368E (NPN Transistor)

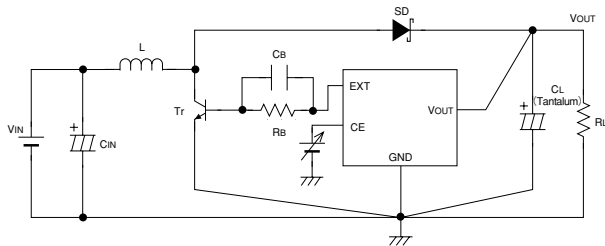

Circuit 12. XC6367F, XC6368F (NPN Transistor)

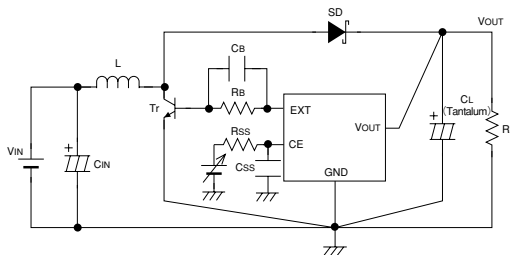

Recommended Components

Tr : XP161A1355PR (Torex N-channel Power MOSFET)
 As the breakdown voltage of XP161A1355PR is 6V, take care with the power supply voltage. With output voltages over 6V, use the XP161A1265PR with a breakdown voltage of 12V.
 Vst1 : XP161A1355PR = 1.2V (max)
 XP161A1265PR = 1.5V (max)
 L : 22μH (Sumida CR54, Fosc=300kHz)
 47μH (Sumida CR75, Fosc=100, 180kHz)
 10μH (Sumida CR54, Fosc=500kHz)
 SD : MA2Q735 (Schottky Diode, Matsushita)
 Cn : 16V 220μF (Aluminium Electrolytic Capacitor)
 Cl : 16V 47μF + 47μF (Tantalum capacitor, Nichicon MCE)

NPN Tr type :

Tr : 2SD1628 (Sanyo)
 Rb : 500Ω (Adjust according to load and Tr. hFE levels)
 Cb : 2200pF (Ceramic type)

Set up so that $C_b \leq 1 + (2\pi \times R_b \times F_{osc} \times 0.7)$

4

C, D, F type (soft-start externally set-up) :

Css : 0.1μF (Ceramic capacitor)
 Rss : 470kΩ (C, F type), 220kΩ (D type)

B, D type (FB versions)

Rfb : Set up so that $R_{fb1} + R_{fb2} = V_{out} - 1$ (V_{out} = set-up output voltage).
 Please use with $R_{fb1} + R_{fb2} \leq 2M\Omega$.
 Cfb : Set up so that $f_{zfb} = 1 - (2 \times \pi \times C_{fb} \times R_{fb1})$ is within the 0.1 to 20kHz range (10kHz conventional).
 Adjustments necessary in respect of L, Cl.
 e.g. $V_{out} = 3.0V$
 $R_{fb1} = 400k\Omega$, $R_{fb2} = 200k\Omega$, $C_{fb} = 47pF$

If using a Torex MOSFET, We recommend using one which has a gate protection diode built-in.

Gate Protection Diode Built-in	
	XP161A1355PR
Rds(ON)	0.15 Ω @ Vgs=1.5V
	XP161A1265PR
Rds(ON)	0.095 Ω @ Vgs=2.5V

XC6367/6368 Series

Directions for use

Notes on Use

Take ample care to ensure that none of the IC's, nor the external component's, absolute maximum ratings are exceeded. Be extremely careful when selecting parts and do not limit your reference to the specifications and characteristics for the DC/DC converter alone. The IC also depends, to a great extent, upon the external components. Arrange the peripherals in the environs of the IC. In order to reduce wiring impedance, use short, thick wires. In particular, wire the load capacitor as close as possible and strengthen the ground wiring sufficiently. Ground current during switching may cause the IC's operations to become unstable due to changes in ground voltage, so please strengthen the IC's GND pin surroundings.

External Components

4

1. Soft start time set up

If you wish to lengthen soft start time we recommend that you use the C or D versions of the series which have soft start time externally set up. Soft start time (Tss) is between MIN & MAX, as indicated in the graphs below, so please select soft start condenser capacitance (C_{SS}) to suit your application.

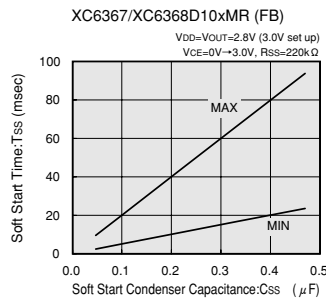
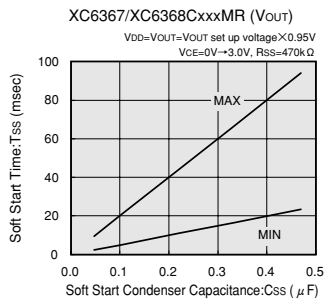

2. RFB1, CFB set up

$$f_{zfb} = 1 \div (2\pi \times C_{FB} \times R_{FB1})$$

In order to achieve a value for f_{zfb} within the range of 0.1kHz to 20kHz, we recommend that values for R_{FB1} & C_{FB} are selected from the area indicated within the lines of f_{zfb} = 0.1kHz and f_{zfb} = 20 kHz as shown on the graph below. Please select combinations of values as close to the f_{zfb} = 10kHz line as possible.

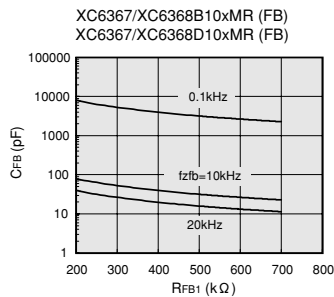

Typical Performance Characteristics

(1) OUTPUT VOLTAGE vs. OUTPUT CURRENT

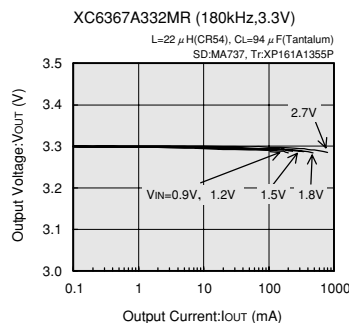
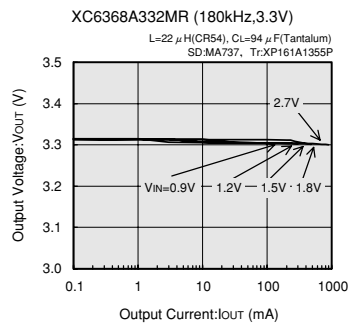
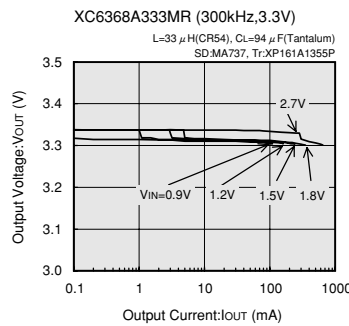
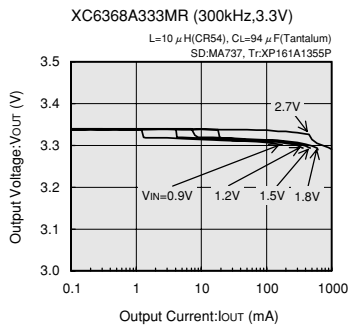
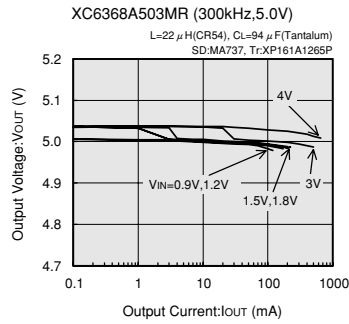
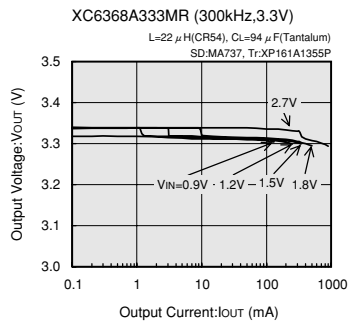

Note: (External component) CIN=220 μ F(Electrolytic capacitor)

4

XC6367/6368 Series

(1) OUTPUT VOLTAGE vs. OUTPUT CURRENT

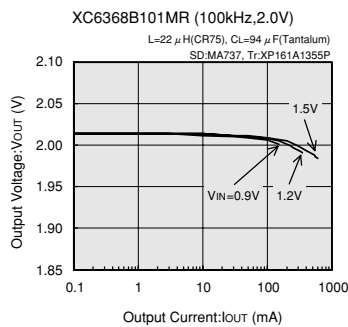
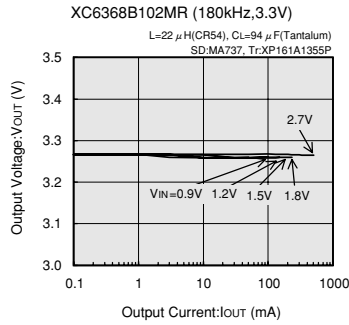
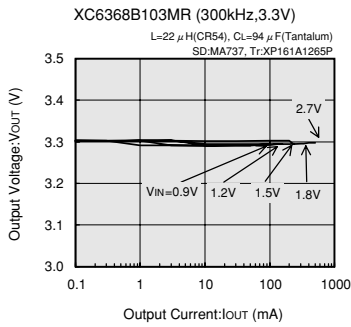
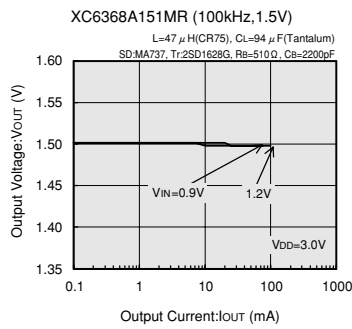
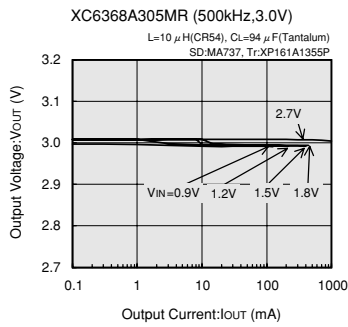

Note: (External component) CIN=220 μ F(Electrolytic capacitor)

(2) EFFICIENCY vs. OUTPUT CURRENT

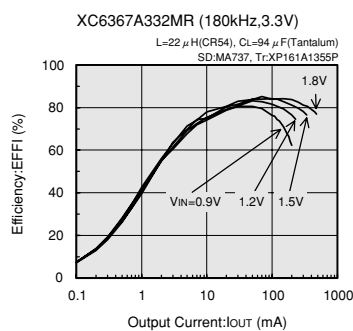
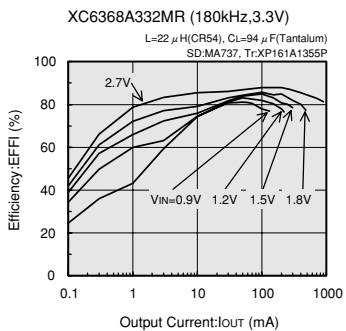
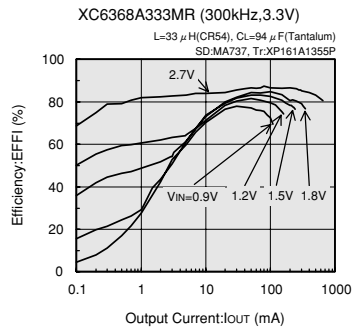
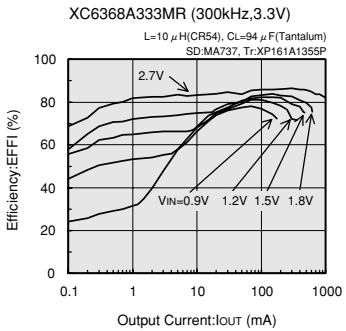
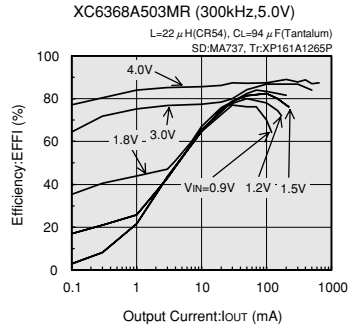
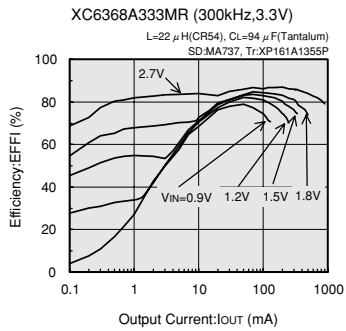

Note: (External component) CIN=220 μ F(Electrolytic capacitor)

4

XC6367/6368 Series

(2) EFFICIENCY vs. OUTPUT CURRENT

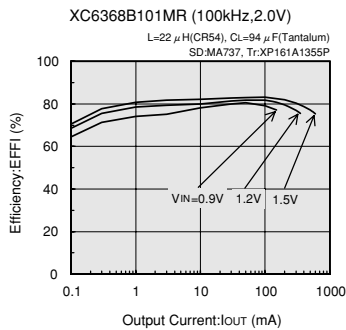
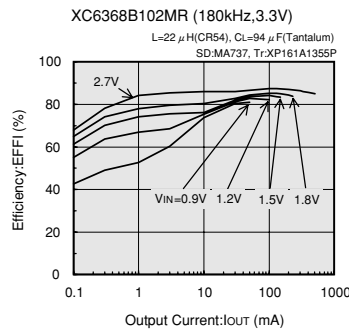
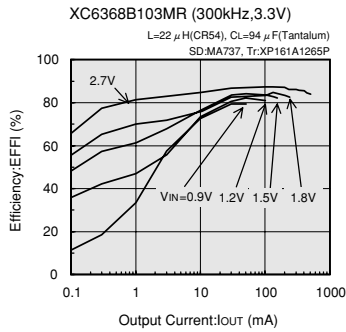
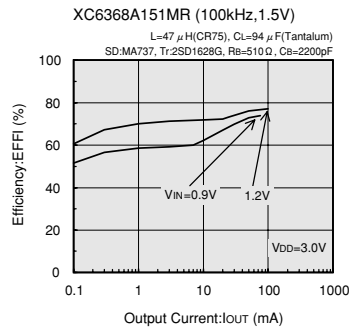
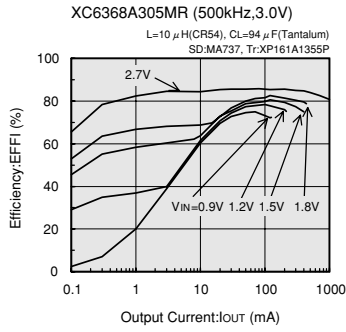

Note: (External component) CIN=220 μ F(Electrolytic capacitor)

XC6367/6368
Series

(3) RIPPLE VOLTAGE vs. OUTPUT CURRENT

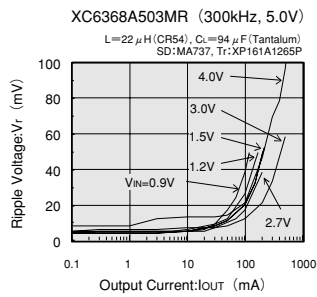
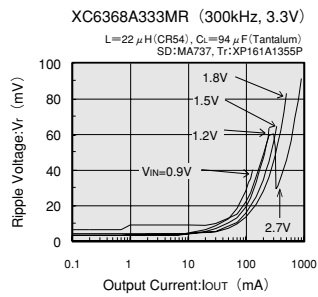

4

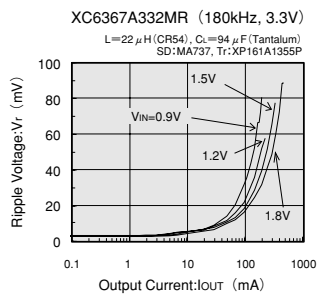
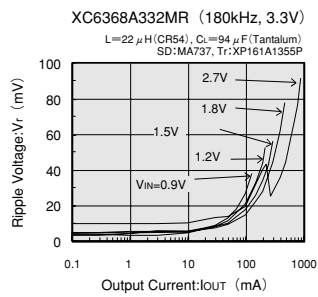
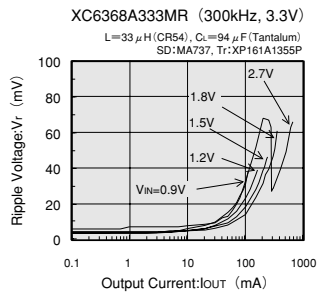
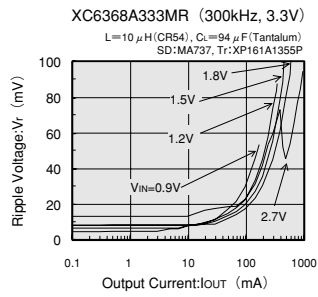

XC6367/6368 Series

(3) RIPPLE VOLTAGE vs. OUTPUT CURRENT

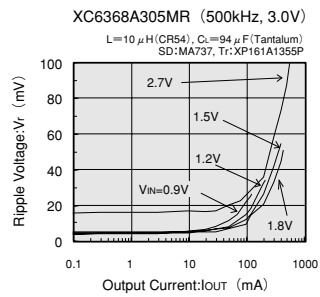

XC6367/6368
Series

(4) OUTPUT VOLTAGE vs. AMBIENT TEMPERATURE

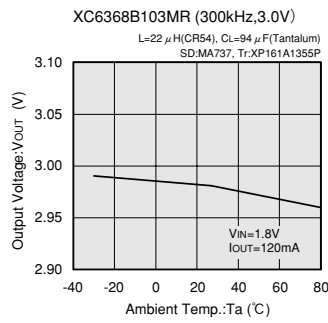

(5) SUPPLY CURRENT 1 vs. AMBIENT TEMPERATURE

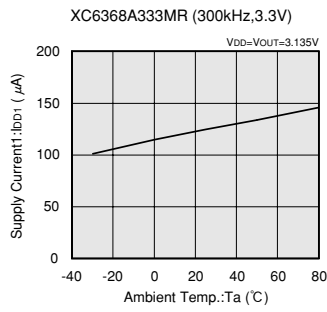

(6) SUPPLY CURRENT 2 vs. AMBIENT TEMPERATURE

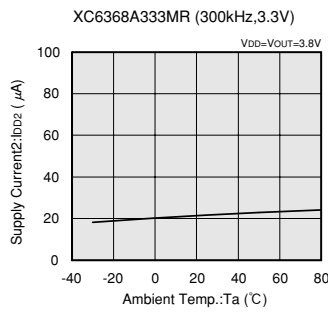

(7) STAND-BY CURRENT vs. AMBIENT TEMPERATURE

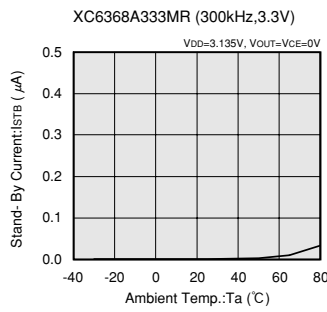

4

(8) EXT^H ON RESISTANCE vs. AMBIENT TEMPERATURE

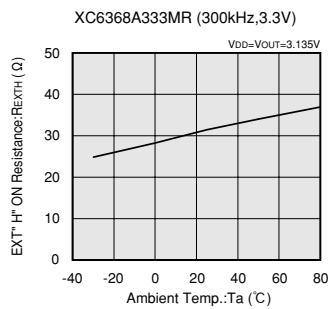

(9) EXT^L ON RESISTANCE vs. AMBIENT TEMPERATURE

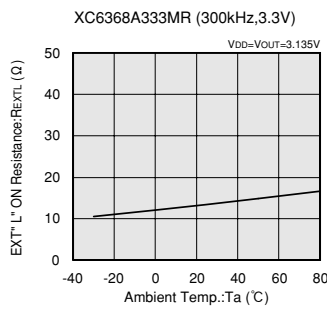

XC6367/6368 Series

(10) OSCILLATION FREQUENCY vs. AMBIENT TEMPERATURE (11) MAX. DUTY RATIO vs. AMBIENT TEMPERATURE

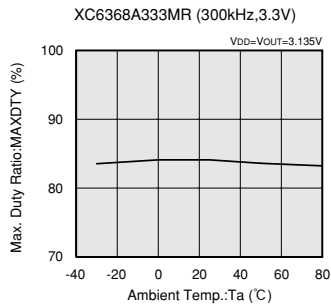
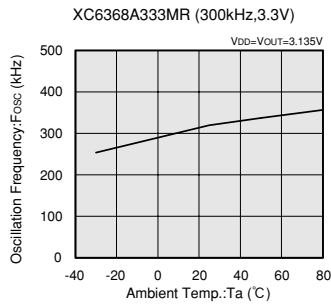

4

(12) PFM DUTY RATIO vs. AMBIENT TEMPERATURE (13) EFFICIENCY vs. AMBIENT TEMPERATURE

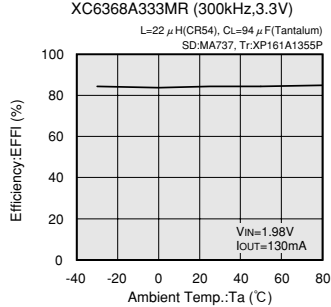
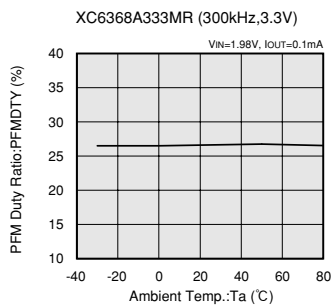

(14) OPERATING START VOLTAGE vs. AMBIENT TEMPERATURE (15) OPERATING HOLD VOLTAGE vs. AMBIENT TEMPERATURE

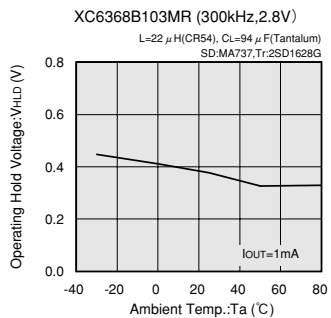
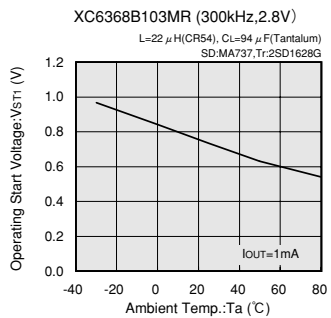

XC6367/6368
Series

(16) OSCILLATION START VOLTAGE vs. AMBIENT TEMPERATURE (17) SOFT START TIME vs. AMBIENT TEMPERATURE

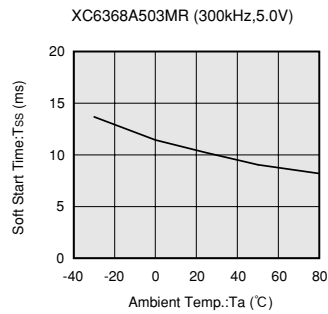
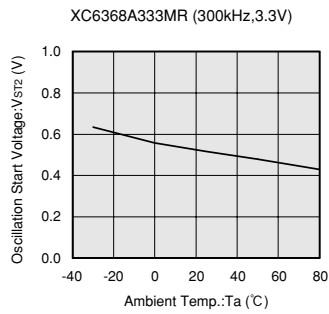

(18) CE "L" VOLTAGE vs. AMBIENT TEMPERATURE

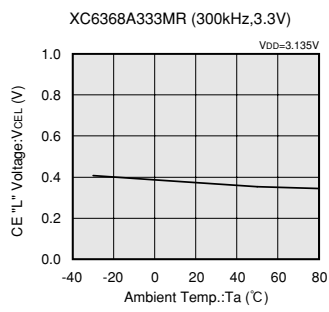

(19) CE "H" VOLTAGE vs. AMBIENT TEMPERATURE

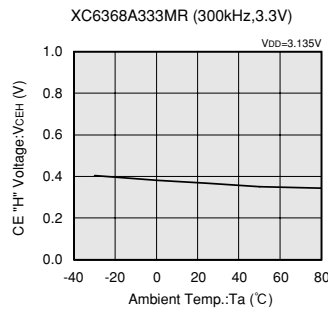

4

XC6367/6368 Series

(20) LOAD TRANSIENT RESPONSE

