

### Preliminary

- ◆ CMOS Low Power Consumption
- ◆ Small Input-Output Voltage Differential:  
0.18V at 60mA, 0.58V at 160mA
- ◆ Maximum Output Current: 165mA ( $V_{OUT}=3.0V$ )
- ◆ Highly Accurate:  $\pm 2\%$ ( $\pm 1\%$ )
- ◆ Output Voltage Range: 2.0V~6.0V
- ◆ Standby Supply Current 0.1 $\mu$ A( $V_{OUT}=3.0V$ )
- ◆ SOT-25/SOT-89-5 Package

### General Description

The XC62H series are highly precise, low power consumption, positive voltage regulators, manufactured using CMOS and laser trimming technologies. The series consists of a high precision voltage reference, an error correction circuit, and an output driver with current limitation.

By way of the CE function, with output turned off, the series enters stand-by. In the stand-by mode, power consumption is greatly reduced.

SOT-25 (150mW) and SOT-89-5 (500mW) packages are available.

In relation to the CE function, as well as the positive logic XC62HR series, a negative logic XC62HP series (custom) is also available.

### Output On/Off Control

#### Applications

- Battery Powered Instruments
- Voltage supplies for cellular phones
- Cameras and Video Recorders
- Palmtops

#### Features

**Maximum Output Current:** 165mA (within Maximum power dissipation,  $V_{OUT}=3.0V$ )

**Output Voltage Range:** 2.0V ~ 6.0V in 0.1V increments  
(1.1V to 1.9V semi-custom)

**Highly Accurate:** Set-up Voltage  $\pm 2\%$  ( $\pm 1\%$  for semi-custom products)

**Low power consumption:** TYP 3.0 $\mu$ A ( $V_{OUT}=3.0$ , Output enabled)  
TYP 0.1 $\mu$ A (Output disabled)

**Output voltage temperature characteristics:** TYP  $\pm 100$ ppm/ $^{\circ}$ C

**Input stability:** TYP 0.2%/V

**Ultra small package:** SOT-25 (150mW) mini-mold  
SOT-89-5 (500mW) mini-power mold

### Pin Configuration

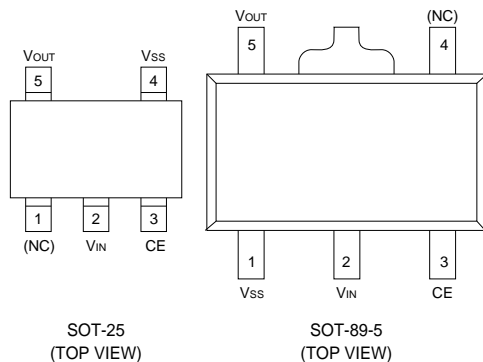

### Pin Assignment

PIN NUMBER		PIN NAME	FUNCTION
SOT-25	SOT-89-5		
1	4	(NC)	No Connection
2	2	$V_{IN}$	Supply Voltage Input
3	3	CE	Chip Enable
4	1	$V_{SS}$	Ground
5	5	$V_{OUT}$	Regulated Output Voltage

### Function

SERIES	CE	VOLTAGE OUTPUT
XC62HR	H	ON
	L	OFF
XC62HP	H	OFF
	L	ON

H=High, L=Low

### Block Diagram

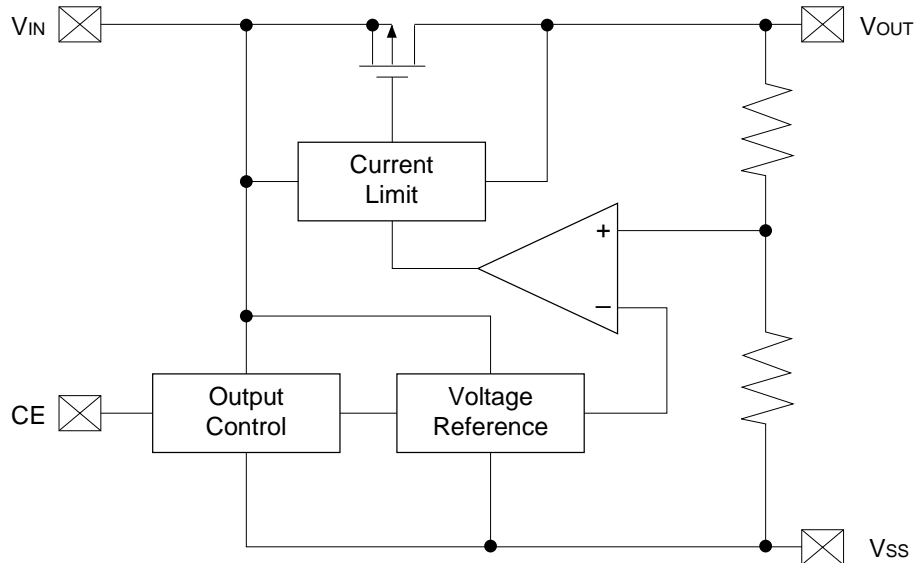

### Absolute Maximum Ratings

$T_a=25^\circ\text{C}$

PARAMETER	SYMBOL	RATINGS	UNITS
Input Voltage	$V_{IN}$	12	V
Output Current	$I_{OUT}$	500	mA
Output Voltage	$V_{OUT}$	$V_{SS}-0.3 \sim V_{IN}+0.3$	V
CE Input Voltage	$V_{CE}$	$V_{SS}-0.3 \sim V_{IN}+0.3$	V
Continuous Total Power Dissipation	SOT-25	$P_d$	150
	SOT-89-5	$P_d$	500
Operating Ambient Temperature	$T_{opr}$	$-30 \sim +80$	$^\circ\text{C}$
Storage Temperature	$T_{stg}$	$-40 \sim +25$	$^\circ\text{C}$

Note:  $I_{OUT}$  must be less than  $P_d / (V_{IN}-V_{OUT})$ .

### Standard Circuit

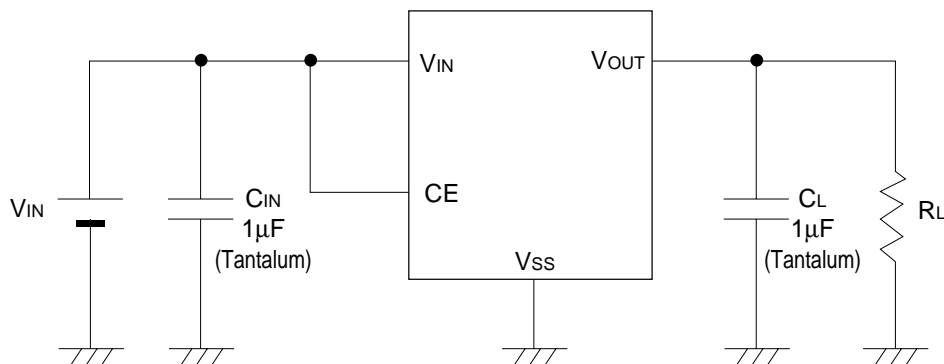

## ■ Electrical Characteristics

XC62HR2002  $V_{OUT}(T)=2.0V$ (Note1)

$T_a=25^{\circ}C$

PARAMETER	SYMBOL	CONDITIONS	MIN	TYP	MAX	UNITS	CIRCUIT
Output Voltage	$V_{OUT}(E)$ (Note2)	$I_{OUT}=40mA$ $V_{IN}=3.0V$	1.960	2.000	2.040	V	1
Maximum Output Current	$I_{OUT\ max}$	$V_{IN}=3.0V, V_{OUT}(E) \geq 1.8V$	115			mA	1
Load Stability	$\Delta V_{OUT}$	$V_{IN}=3.0V$ $1mA \leq I_{OUT} \leq 60mA$		45	90	mV	1
Input -Output Voltage Differential (Note3)	$V_{dif1}$	$I_{OUT}=40mA$		180	360	mV	1
	$V_{dif2}$	$I_{OUT}=100mA$		580	880	mV	1
Supply Current1	ISS1	$V_{IN}=V_{CE}=3.0V$		2.9	7.9	$\mu A$	2
Supply Current2	ISS2	$V_{IN}=3.0V, V_{CE}=V_{SS}$			0.1	$\mu A$	2
Input Stability	$\frac{\Delta V_{OUT}}{\Delta V_{IN} \cdot V_{OUT}}$	$I_{OUT}=40mA$ $3.0V \leq V_{IN} \leq 10.0V$		0.2	0.3	%/V	1
Input Voltage	$V_{IN}$				10.0	V	—
Output Voltage Temperature Characteristics	$\frac{\Delta V_{OUT}}{\Delta T_{opr} \cdot V_{OUT}}$	$I_{OUT}=40mA$ $-30^{\circ}C \leq T_{opr} \leq 80^{\circ}C$		$\pm 100$		ppm/ $^{\circ}C$	1
CE "High" Voltage	$V_{CEH}$		1.5			V	1
CE "Low" Voltage	$V_{CEL}$				0.25	V	1
CE "High" Current	$I_{CEH}$	$V_{CE}=V_{IN}$			5.0	$\mu A$	2
CE "Low" Current	$I_{CEL}$	$V_{CE}=V_{SS}$	-0.2	-0.05	0	$\mu A$	2

- Note: 1.  $V_{OUT}(T)$ =Specified Output Voltage .  
 2.  $V_{OUT}(E)$ =Effective Output Voltage (i.e. the output voltage when " $V_{OUT}(T)+1.0V$ " is provided at the  $V_{IN}$  pin while maintaining a certain  $I_{OUT}$  value).  
 3.  $V_{dif} = \{V_{IN1} (Note5) - V_{OUT1} (Note4)\}$   
 4.  $V_{OUT1}$ = A voltage equal to 98% of the Output Voltage whenever an amply stabilised  $I_{OUT}$  ( $V_{OUT}(T)+1.0V$ ) is input.  
 5.  $V_{IN1}$ = The Input Voltage when  $V_{OUT1}$  appears as Input Voltage is gradually decreased.

### Electrical Characteristics

XC62HR3002  $V_{OUT}(T)=3.0V$ (Note1)

$T_a=25^{\circ}C$

PARAMETER	SYMBOL	CONDITIONS	MIN	TYP	MAX	UNITS	CIRCUIT
Output Voltage	$V_{OUT}(E)$ (Note2)	$I_{OUT}=40mA$ $V_{IN}=4.0V$	2.940	3.000	3.060	V	1
Maximum Output Current	$I_{OUT\ max}$	$V_{IN}=4.0V, V_{OUT}(E) \geq 2.7V$	165			mA	1
Load Stability	$\Delta V_{OUT}$	$V_{IN}=4.0V$ $1mA \leq I_{OUT} \leq 80mA$		45	90	mV	1
Input -Output Voltage Differential (Note3)	$V_{dif1}$	$I_{OUT}=60mA$		180	360	mV	1
	$V_{dif2}$	$I_{OUT}=160mA$		580	880	mV	1
Supply Current1	ISS1	$V_{IN}=V_{CE}=4.0V$		3.0	8.0	$\mu A$	2
Supply Current2	ISS2	$V_{IN}=4.0V, V_{CE}=V_{SS}$			0.1	$\mu A$	2
Input Stability	$\frac{\Delta V_{OUT}}{\Delta V_{IN} \cdot V_{OUT}}$	$I_{OUT}=40mA$ $4.0V \leq V_{IN} \leq 10.0V$		0.2	0.3	%/V	1
Input Voltage	$V_{IN}$				10.0	V	—
Output Voltage Temperature Characteristics	$\frac{\Delta V_{OUT}}{\Delta T_{opr} \cdot V_{OUT}}$	$I_{OUT}=40mA$ $-30^{\circ}C \leq T_{opr} \leq 80^{\circ}C$		$\pm 100$		ppm/ $^{\circ}C$	1
CE "High" Voltage	VCEH		1.5			V	1
CE "Low" Voltage	VCEL				0.25	V	1
CE "High" Current	ICEH	$V_{CE}=V_{IN}$			5.0	$\mu A$	2
CE "Low" Current	ICEL	$V_{CE}=V_{SS}$	-0.2	-0.05	0	$\mu A$	2

- Note: 1.  $V_{OUT}(T)$ =Specified Output Voltage .  
 2.  $V_{OUT}(E)$ =Effective Output Voltage (i.e. the output voltage when " $V_{OUT}(T)+1.0V$ " is provided at the  $V_{IN}$  pin while maintaining a certain  $I_{OUT}$  value).  
 3.  $V_{dif} = \{V_{IN1} \text{ (Note5)} - V_{OUT1} \text{ (Note4)}\}$   
 4.  $V_{OUT1}$ = A voltage equal to 98% of the Output Voltage whenever an amply stabilised  $I_{OUT}$  ( $V_{OUT}(T)+1.0V$ ) is input.  
 5.  $V_{IN1}$ = The Input Voltage when  $V_{OUT1}$  appears as Input Voltage is gradually decreased.  
 6. Semi-custom.

## Electrical Characteristics

XC62HR4002  $V_{OUT}(T)=4.0V$ (Note1)

$T_a=25^{\circ}C$

PARAMETER	SYMBOL	CONDITIONS	MIN	TYP	MAX	UNITS	CIRCUIT
Output Voltage	$V_{OUT}(E)$ (Note2)	$I_{OUT}=40mA$ $V_{IN}=5.0V$	3.920	4.000	4.080	V	1
Maximum Output Current	$I_{OUT\ max}$	$V_{IN}=5.0V, V_{OUT}(E) \geq 3.6V$	200			mA	1
Load Stability	$\Delta V_{OUT}$	$V_{IN}=5.0V$ $1mA \leq I_{OUT} \leq 100mA$		45	90	mV	1
Input -Output Voltage Differential (Note3)	$V_{dif1}$	$I_{OUT}=80mA$		170	340	mV	1
	$V_{dif2}$	$I_{OUT}=180mA$		560	840	mV	1
Supply Current1	ISS1	$V_{IN}=V_{CE}=5.0V$		3.1	8.1	$\mu A$	2
Supply Current2	ISS2	$V_{IN}=5.0V, V_{CE}=V_{SS}$			0.1	$\mu A$	2
Input Stability	$\frac{\Delta V_{OUT}}{\Delta V_{IN} \cdot V_{OUT}}$	$I_{OUT}=40mA$ $5.0V \leq V_{IN} \leq 10.0V$		0.2	0.3	%/V	1
Input Voltage	$V_{IN}$				10.0	V	—
Output Voltage Temperature Characteristics	$\frac{\Delta V_{OUT}}{\Delta T_{opr} \cdot V_{OUT}}$	$I_{OUT}=40mA$ $-30^{\circ}C \leq T_{opr} \leq 80^{\circ}C$		$\pm 100$		ppm/ $^{\circ}C$	1
CE "High" Voltage	$V_{CEH}$		1.5			V	1
CE "Low" Voltage	$V_{CEL}$				0.25	V	1
CE "High" Current	$I_{CEH}$	$V_{CE}=V_{IN}$			5.0	$\mu A$	2
CE "Low" Current	$I_{CEL}$	$V_{CE}=V_{SS}$	-0.2	-0.05	0	$\mu A$	2

- Note: 1.  $V_{OUT}(T)$ =Specified Output Voltage .  
 2.  $V_{OUT}(E)$ =Effective Output Voltage (i.e. the output voltage when " $V_{OUT}(T)+1.0V$ " is provided at the  $V_{IN}$  pin while maintaining a certain  $I_{OUT}$  value).  
 3.  $V_{dif} = \{V_{IN1} (Note5) - V_{OUT1} (Note4)\}$   
 4.  $V_{OUT1}$ = A voltage equal to 98% of the Output Voltage whenever an amply stabilised  $I_{OUT}$  ( $V_{OUT}(T)+1.0V$ ) is input.  
 5.  $V_{IN1}$ = The Input Voltage when  $V_{OUT1}$  appears as Input Voltage is gradually decreased.  
 6. Semi-custom.

### Electrical Characteristics

XC62HR5002  $V_{OUT}(T)=5.0V$ (Note1)

$T_a=25^{\circ}C$

PARAMETER	SYMBOL	CONDITIONS	MIN	TYP	MAX	UNITS	CIRCUIT
Output Voltage	$V_{OUT}(E)$ (Note2)	$I_{OUT}=40mA$ $V_{IN}=6.0V$	4.900	5.000	5.100	V	1
Maximum Output Current	$I_{OUT\ max}$	$V_{IN}=6.0V, V_{OUT}(E) \geq 4.5V$	220			mA	1
Load Stability	$\Delta V_{OUT}$	$V_{IN}=6.0V$ $1mA \leq I_{OUT} \leq 100mA$		40	80	mV	1
Input -Output Voltage Differential (Note3)	$V_{dif1}$	$I_{OUT}=100mA$		165	320	mV	1
	$V_{dif2}$	$I_{OUT}=200mA$		540	820	mV	1
Supply Current1	ISS1	$V_{IN}=V_{CE}=6.0V$		3.1	8.1	$\mu A$	2
Supply Current2	ISS2	$V_{IN}=6.0V, V_{CE}=V_{SS}$			0.1	$\mu A$	2
Input Stability	$\frac{\Delta V_{OUT}}{\Delta V_{IN} \cdot V_{OUT}}$	$I_{OUT}=40mA$ $6.0V \leq V_{IN} \leq 10.0V$		0.2	0.3	%/V	1
Input Voltage	$V_{IN}$				10.0	V	—
Output Voltage Temperature Characteristics	$\frac{\Delta V_{OUT}}{\Delta T_{opr} \cdot V_{OUT}}$	$I_{OUT}=40mA$ $-30^{\circ}C \leq T_{opr} \leq 80^{\circ}C$		$\pm 100$		ppm/ $^{\circ}C$	1
CE "High" Voltage	VCEH		1.5			V	1
CE "Low" Voltage	VCEL				0.25	V	1
CE "High" Current	ICEH	$V_{CE}=V_{IN}$			5.0	$\mu A$	2
CE "Low" Current	ICEL	$V_{CE}=V_{SS}$	-0.2	-0.05	0	$\mu A$	2

- Note: 1.  $V_{OUT}(T)$ =Specified Output Voltage .  
 2.  $V_{OUT}(E)$ =Effective Output Voltage (i.e. the output voltage when " $V_{OUT}(T)+1.0V$ " is provided at the  $V_{IN}$  pin while maintaining a certain  $I_{OUT}$  value).  
 3.  $V_{dif} = \{V_{IN1} (Note5) - V_{OUT1} (Note4)\}$   
 4.  $V_{OUT1}$ = A voltage equal to 98% of the Output Voltage whenever an amply stabilised  $I_{OUT}$  ( $V_{OUT}(T)+1.0V$ ) is input.  
 5.  $V_{IN1}$ = The Input Voltage when  $V_{OUT1}$  appears as Input Voltage is gradually decreased.  
 6. Semi-custom.

## Ordering Information

XC62Hxxxxxx  
 ↑↑↑↑↑↑↑↑  
 a b c d e f

DESIGNATOR	DESCRIPTION	DESIGNATOR	DESCRIPTION
a	True Logic Level at CE Pin: R=Positive P=Negative(Custom)	e	Package Type M=SOT-25 P=SOT-89-5
b	Output Voltage 30=3.0V 50=5.0V		
c	0	f	Device Orientation R=Embossed Tape (Orientation of Device:Right) L=Embossed Tape (Orientation of Device:Left)
d	Output Voltage Accuracy: 1=±1.0%(Semi-custom) 2=±2.0%		

## Marking

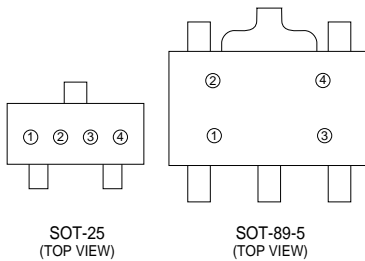

### ① Represents the integer of the Output Voltage

R TYPE POSITIVE VOLTAGE LOGIC SYMBOL	VOLTAGE(V)	P TYPE NEGATIVE VOLTAGE LOGIC SYMBOL	VOLTAGE(V)
0	0.②	0̄	0.②
1	1.②	1̄	1.②
2	2.②	2̄	2.②
3	3.②	3̄	3.②
4	4.②	4̄	4.②
5	5.②	5̄	5.②
6	6.②	6̄	6.②
7	7.②	7̄	7.②
8	8.②	8̄	8.②
9	9.②	9̄	9.②

### ② Represents the decimal point of the Output Voltage

SYMBOL	VOLTAGE(V)	SYMBOL	VOLTAGE(V)
0	①.0	0̄	①.0
1	①.1	1̄	①.1
2	①.2	2̄	①.2
3	①.3	3̄	①.3
4	①.4	4̄	①.4
5	①.5	5̄	①.5
6	①.6	6̄	①.6
7	①.7	7̄	①.7
8	①.8	8̄	①.8
9	①.9	9̄	①.9

### ③ Based on internal standards

SYMBOL
-

### ④ Represents the assembly lot no. 0-9,A-Z repeated (G, I, J, O, Q, W excepted)

### ■ Typical Application Circuit

Circuit 1

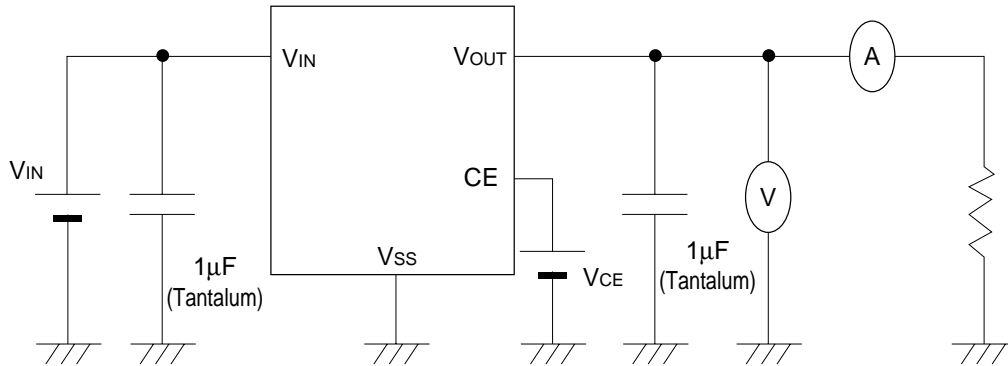

### ■ Typical Application Circuit

Circuit 2

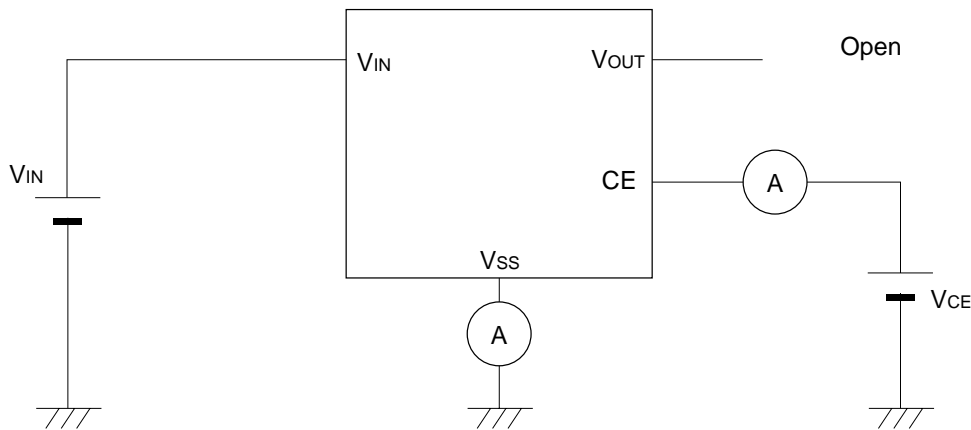



(1) OUTPUT VOLTAGE vs. OUTPUT CURRENT

XC62HR5002 (5V)

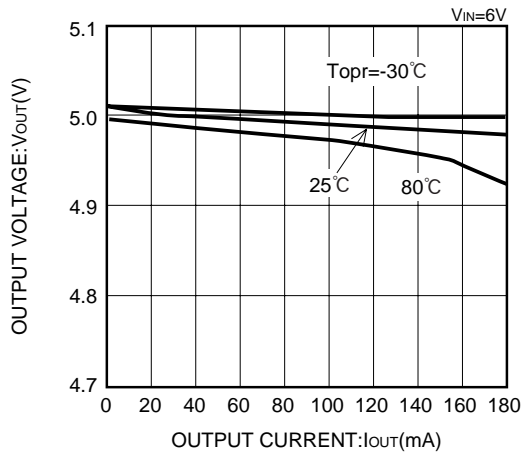

XC62HR4002 (4V)

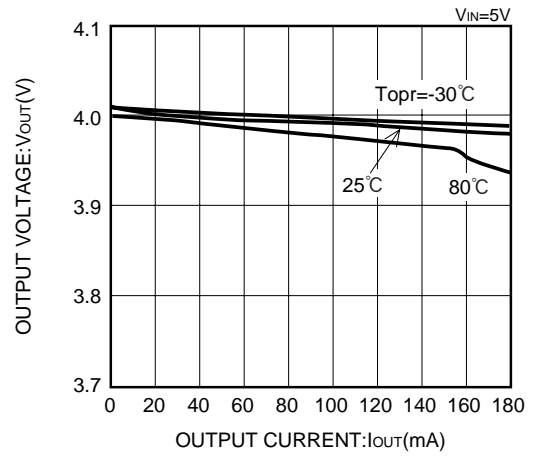

XC62HR3002 (3V)

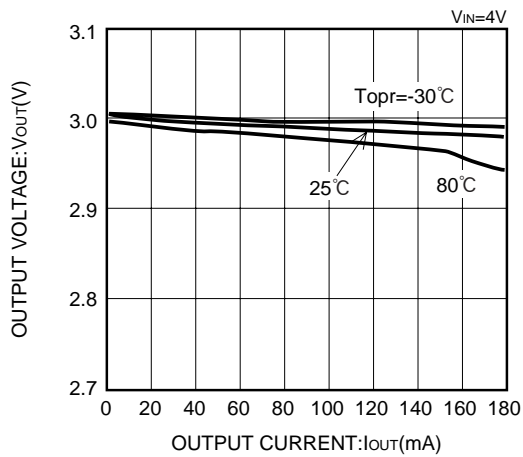

XC62HR2002 (2V)

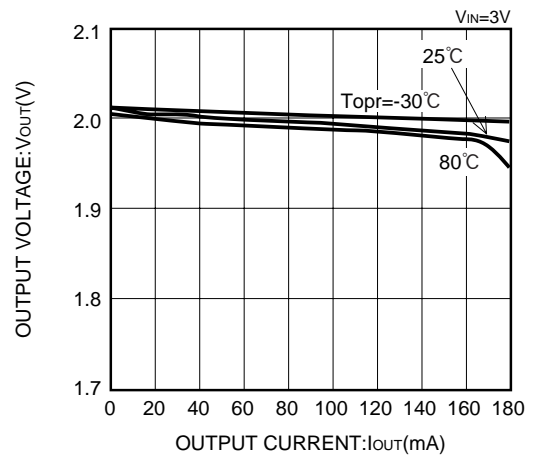

(2) OUTPUT VOLTAGE vs. INPUT VOLTAGE

XC62HR5002 (5V)

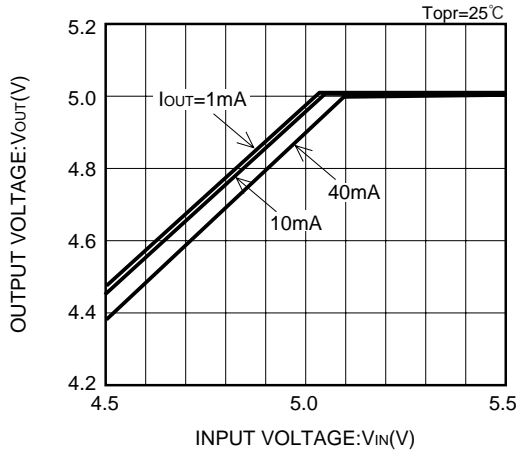

XC62HR5002 (5V)

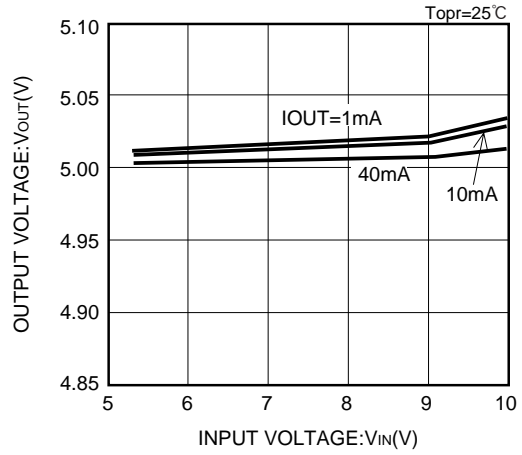

XC62HR4002 (4V)

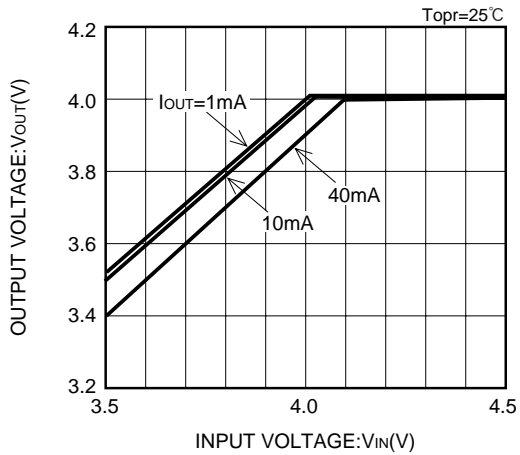

XC62HR4002 (4V)

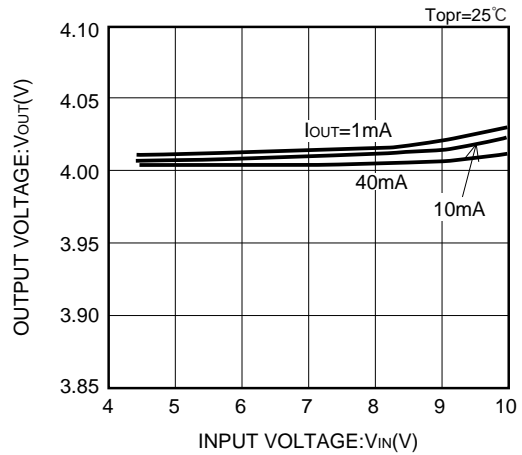

(2) OUTPUT VOLTAGE vs. INPUT VOLTAGE (CONTINUED)

XC62HR3002 (3V)

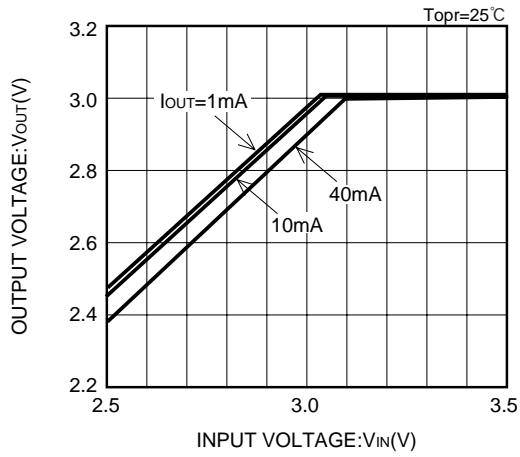

XC62HR3002 (3V)

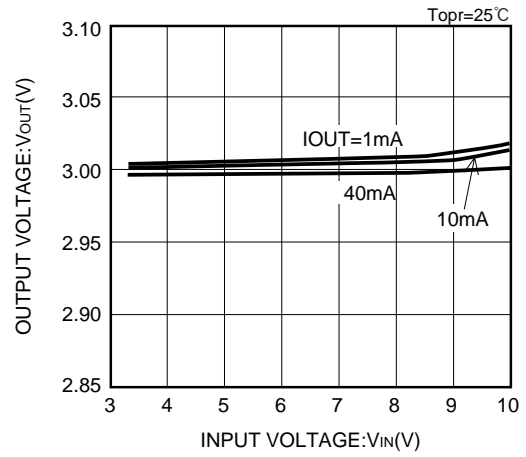

XC62HR2002 (2V)

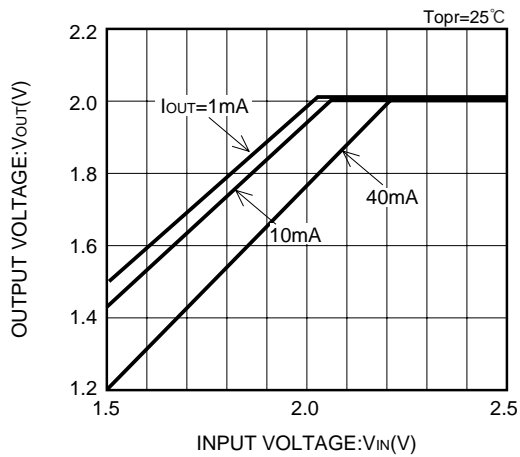

XC62HR2002 (2V)

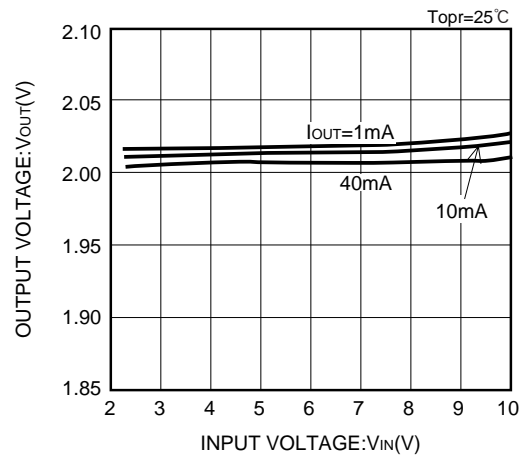

### (3) INPUT/OUTPUT VOLTAGE DIFFERENTIAL vs. OUTPUT CURRENT

XC62HR5002 (5V)

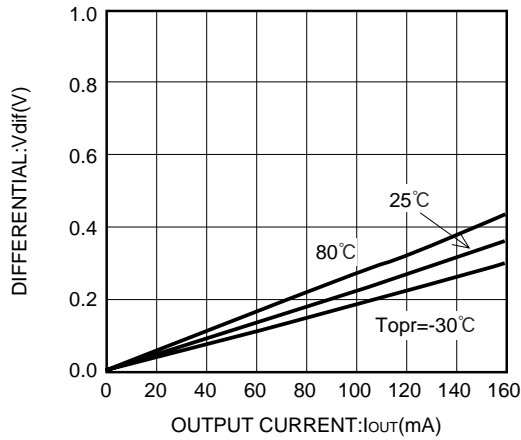

XC62HR4002 (4V)

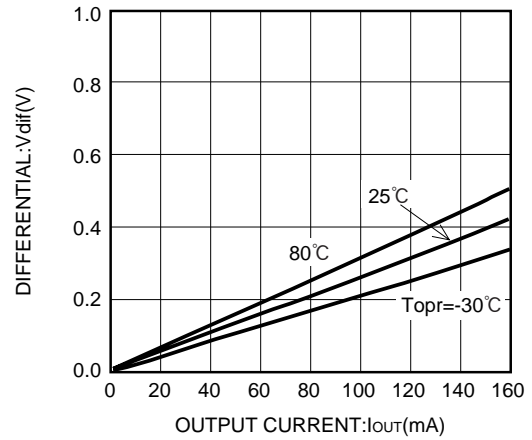

XC62HR3002 (3V)

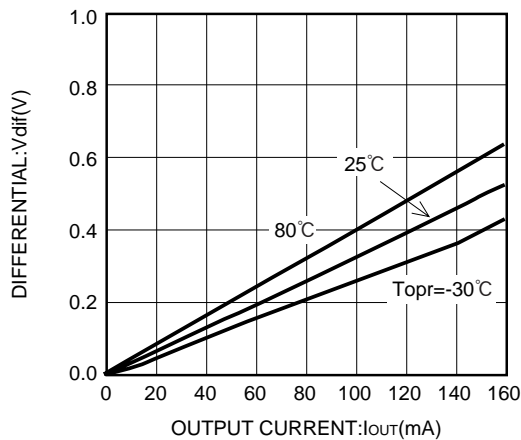

XC62HR2002 (2V)

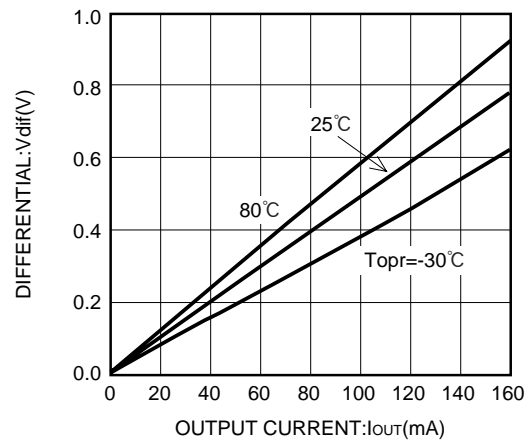

(4) CE PIN THRESHOLD VOLTAGE vs. INPUT VOLTAGE

XC62HR5002 (5V)

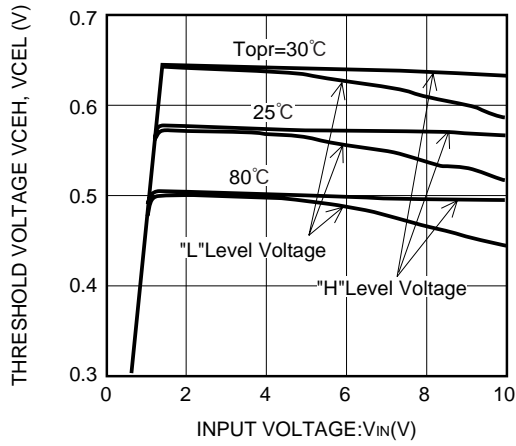

XC62HR4002 (4V)

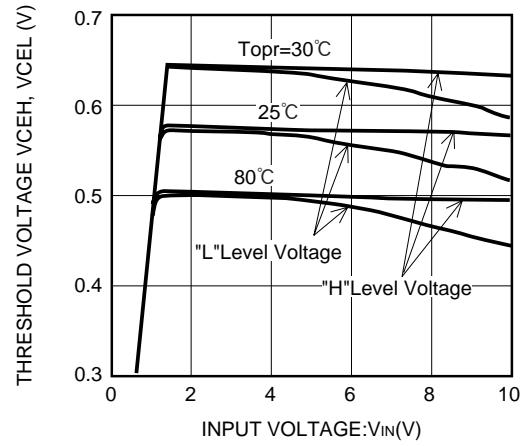

XC62HR3002 (3V)

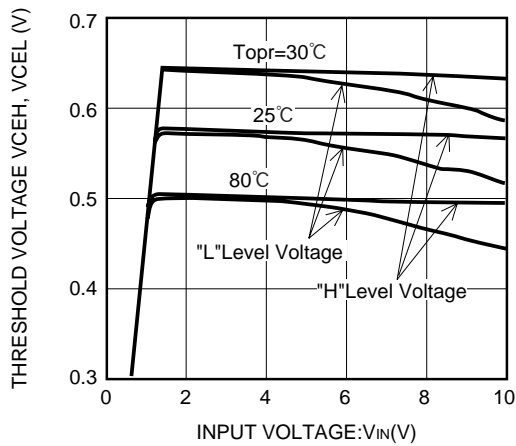

XC62HR2002 (2V)

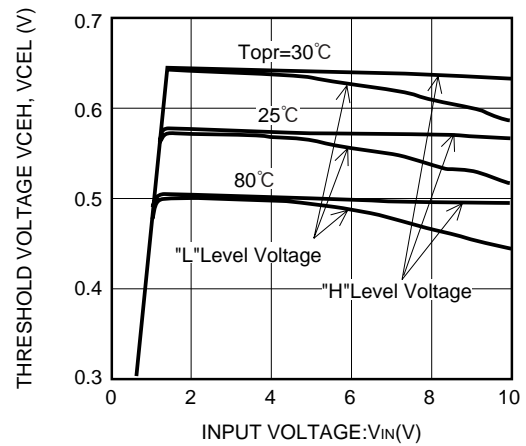

(5) SUPPLY CURRENT vs. INPUT VOLTAGE

XC62HR5002 (5V)

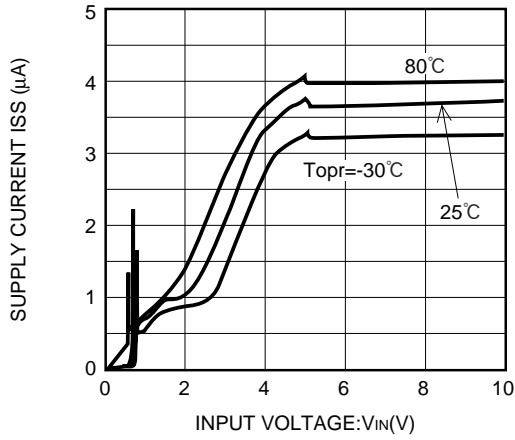

XC62HR5002 (5V)

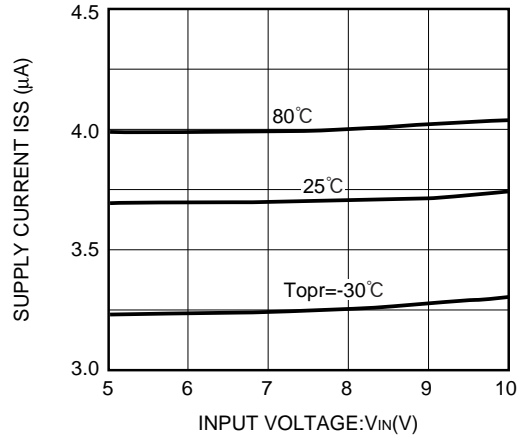

XC62HR4002 (4V)

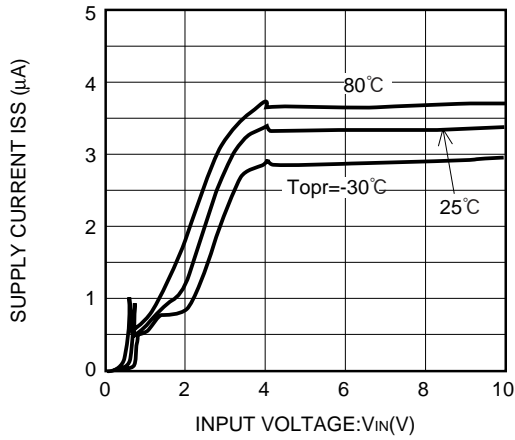

XC62HR4002 (4V)

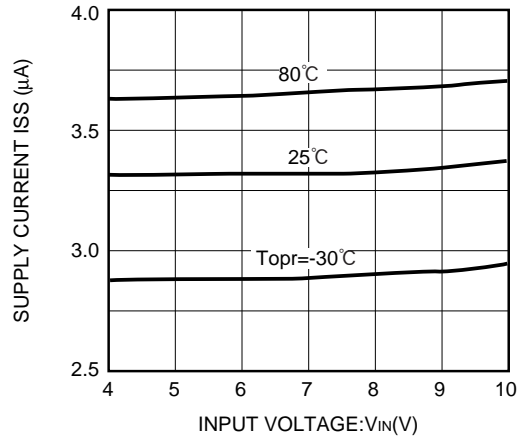

(5) SUPPLY CURRENT vs. INPUT VOLTAGE (CONTINUED)

XC62HR3002 (3V)

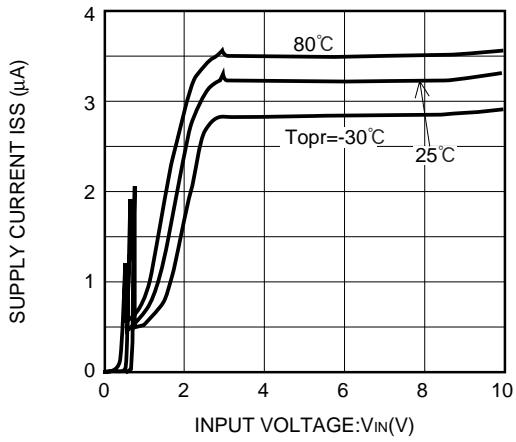

XC62HR3002 (3V)

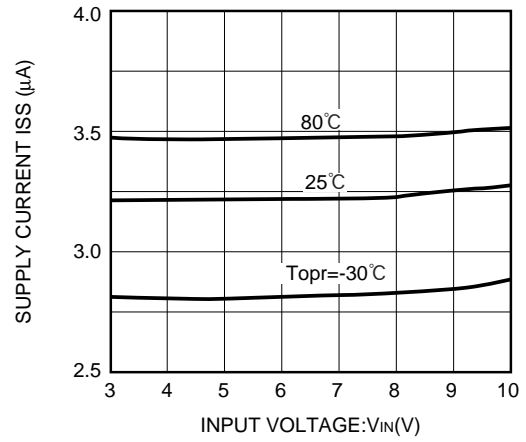

XC62HR2002 (2V)

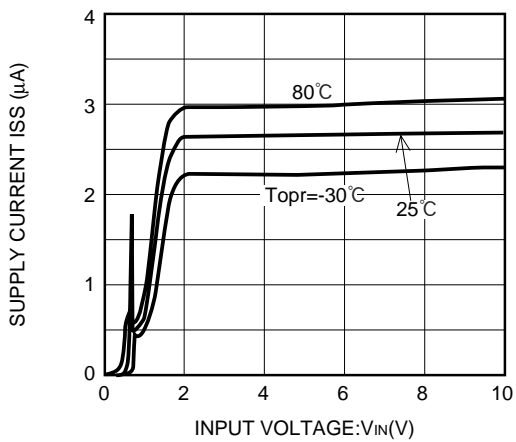

XC62HR2002 (2V)

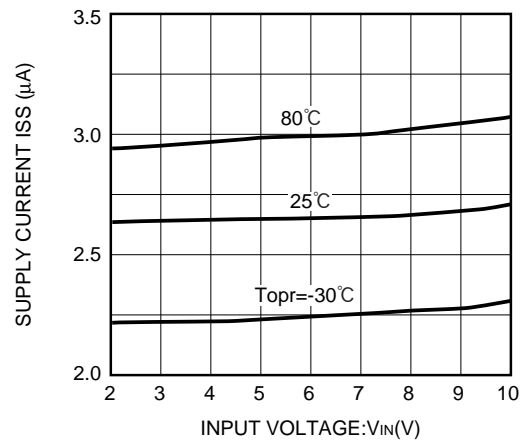

(6) OUTPUT VOLTAGE vs. AMBIENT TEMPERATURE

XC62HR5002 (5V)

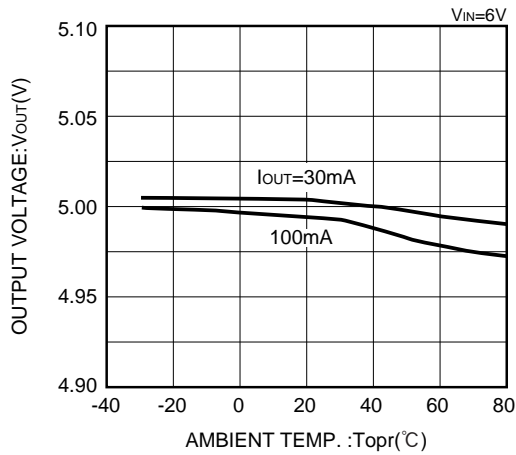

XC62HR4002 (4V)

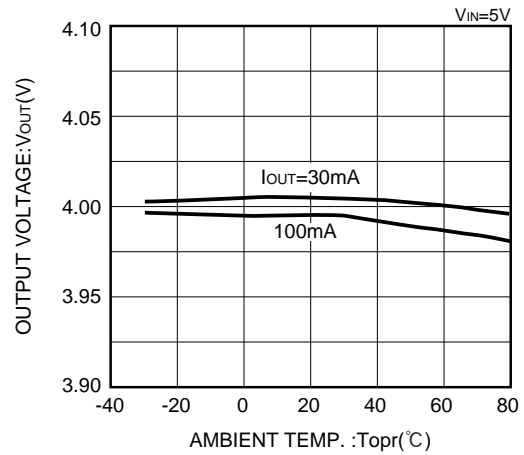

XC62HR3002 (3V)

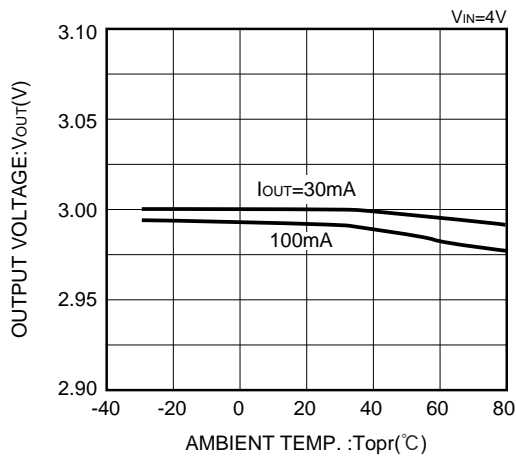

XC62HR2002 (2V)

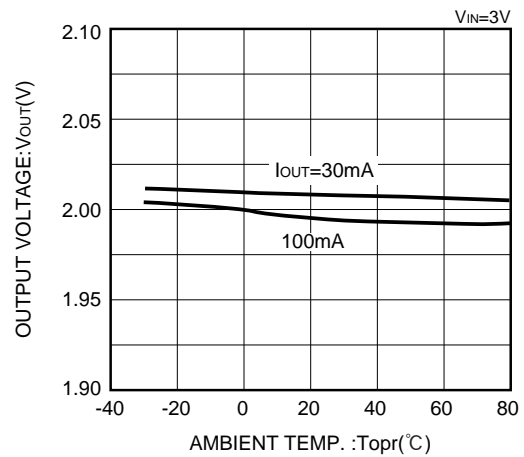



(7) SUPPLY CURRENT vs. AMBIENT TEMPERATURE

XC62HR5002 (5V)

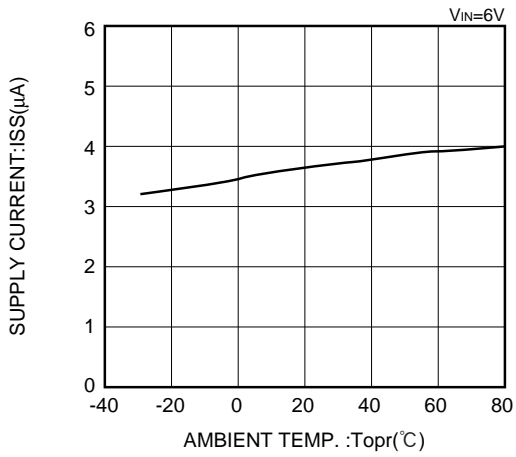

XC62HR4002 (4V)

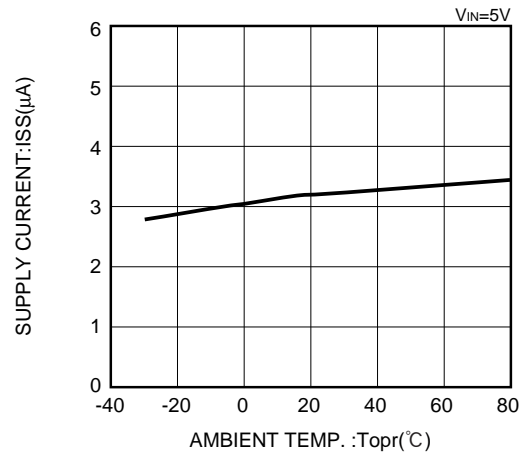

XC62HR3002 (3V)

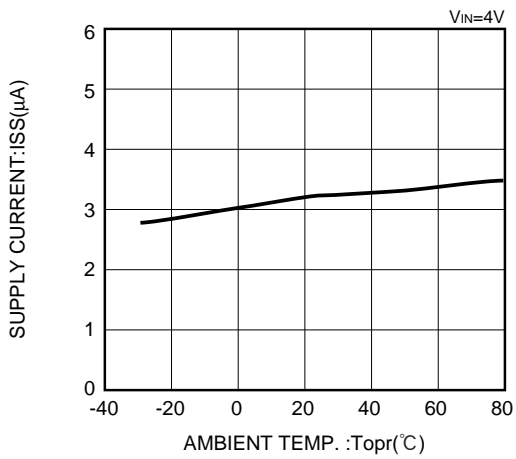

XC62HR2002 (2V)

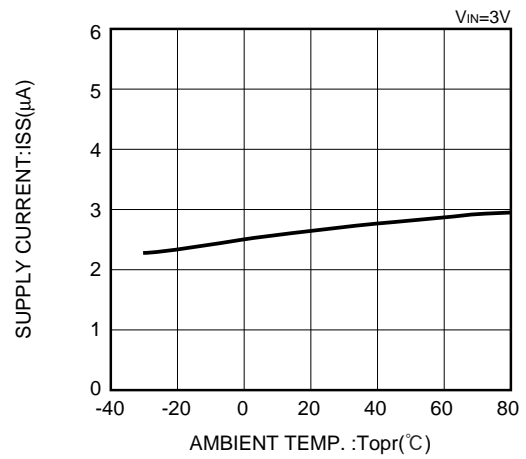

### (8) INPUT TRANSIENT RESPONSE 1

XC62HR5002 (5V)

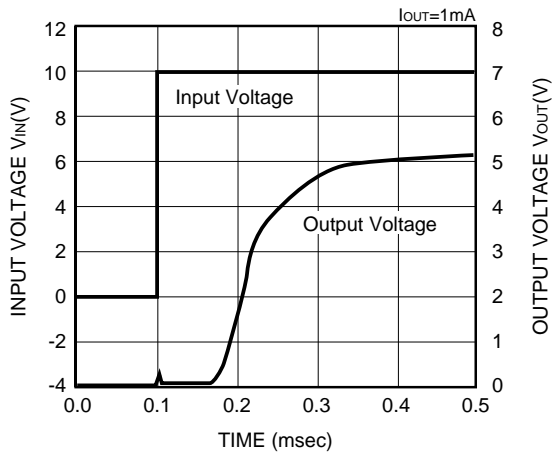

XC62HR5002 (5V)

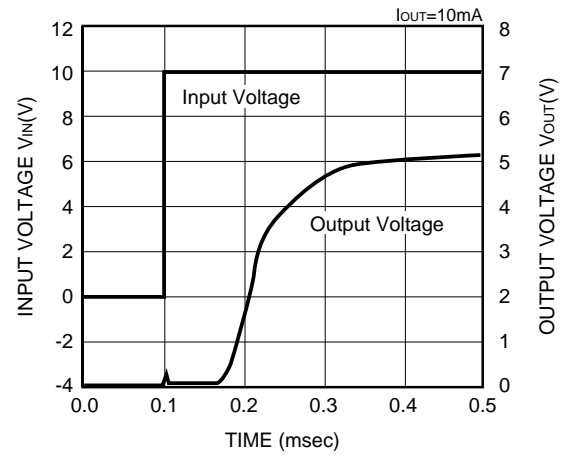

XC62HR5002 (5V)

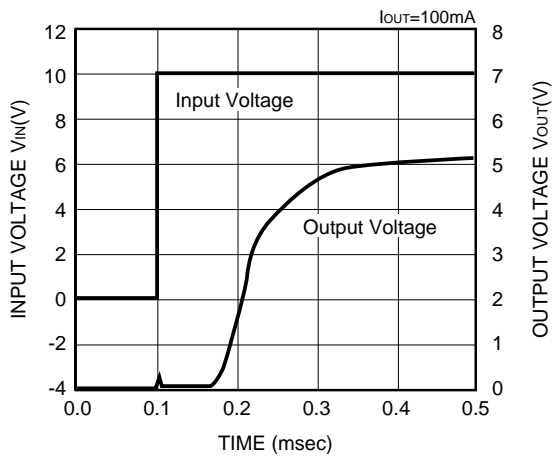

(8) INPUT TRANSIENT RESPONSE 1 (CONTINUED)

XC62HR4002 (4V)

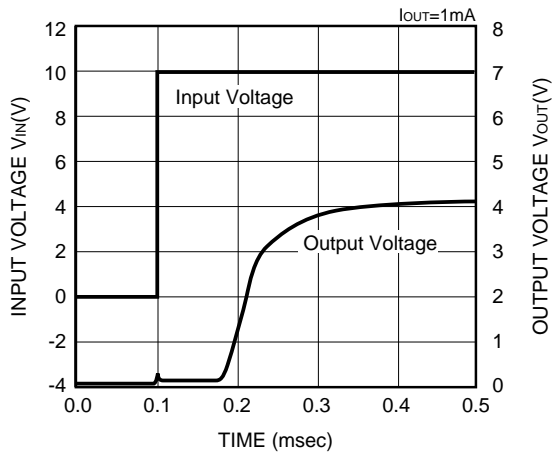

XC62HR4002 (4V)

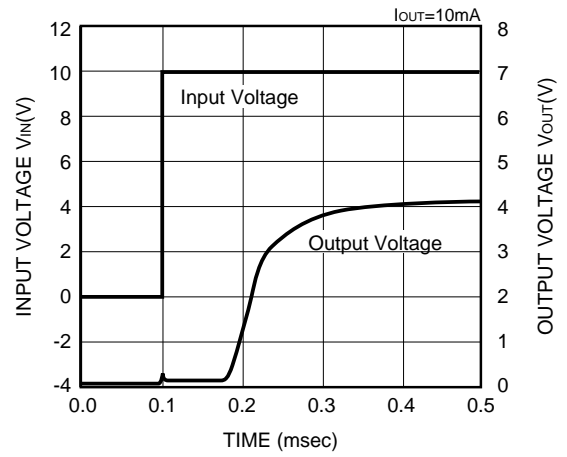

XC62HR4002 (4V)

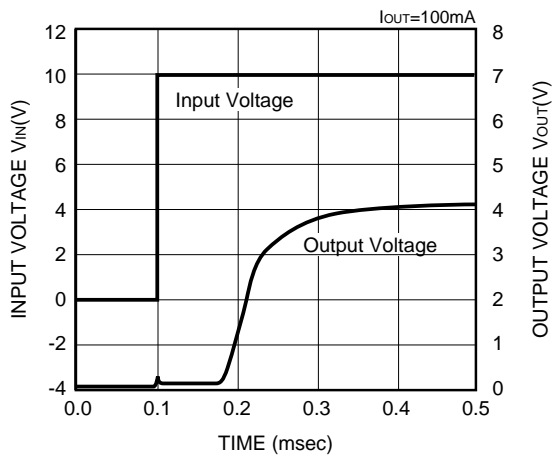

### (8) INPUT TRANSIENT RESPONSE 1 (CONTINUED)

#### XC62HR3002 (3V)

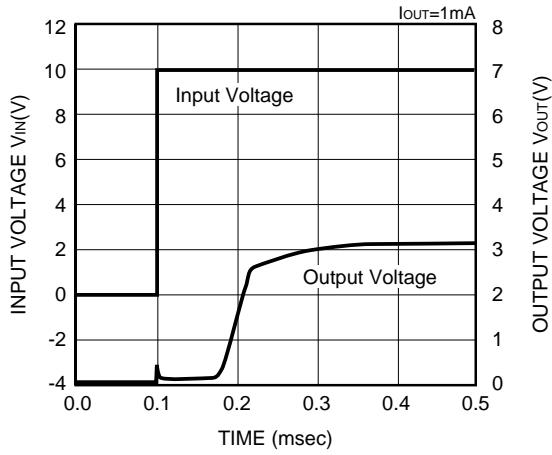

#### XC62HR3002 (3V)

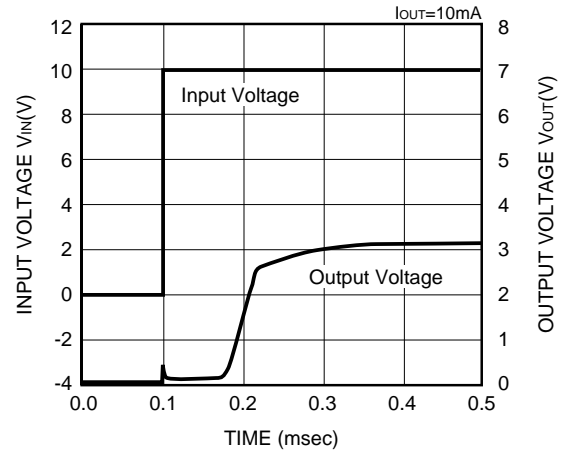

#### XC62HR3002 (3V)

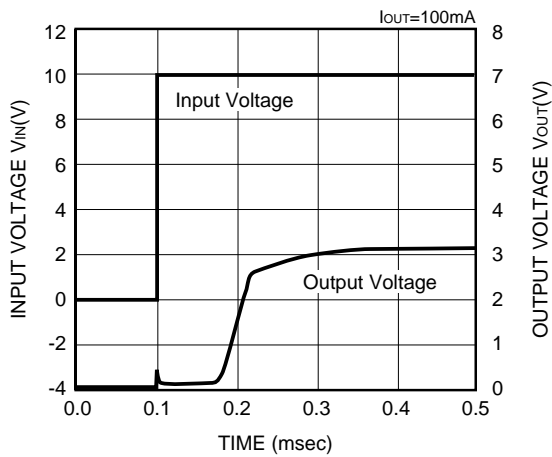

(8) INPUT TRANSIENT RESPONSE 1 (CONTINUED)

XC62HR2002 (2V)

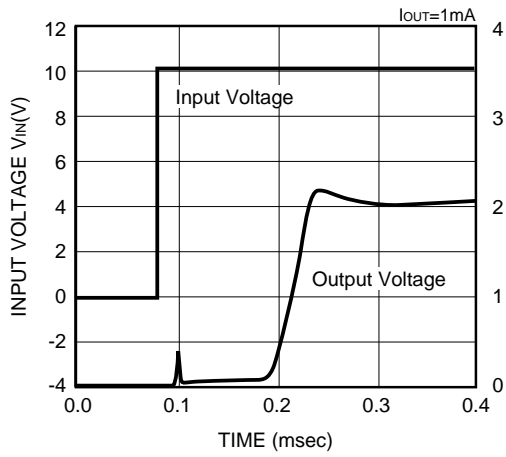

XC62HR2002 (2V)

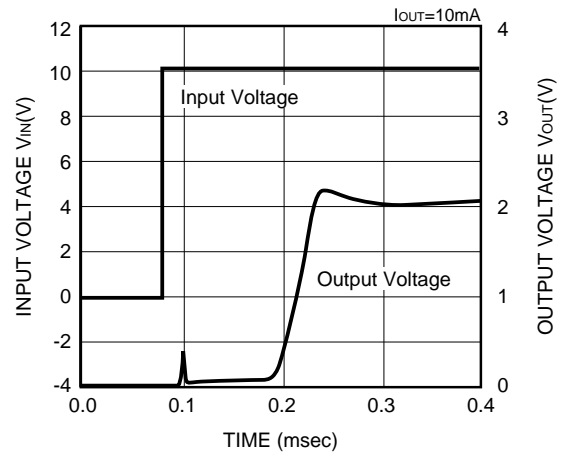

XC62HR2002 (2V)

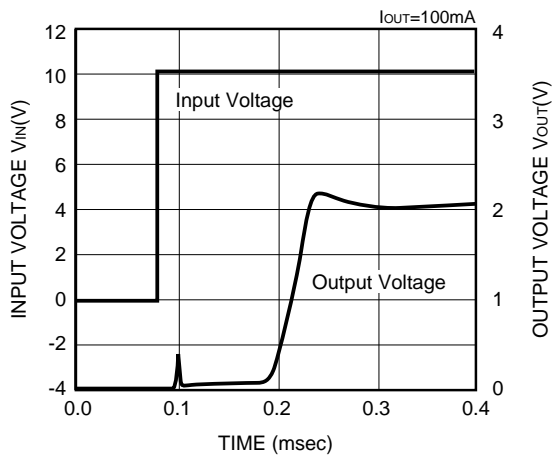

### (9) INPUT TRANSIENT RESPONSE 2

XC62HR5002 (5V)

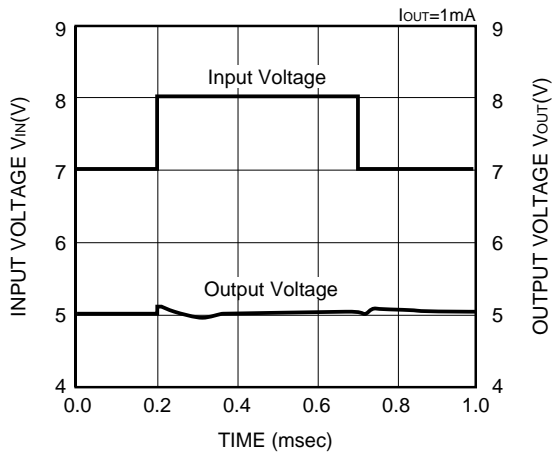

XC62HR5002 (5V)

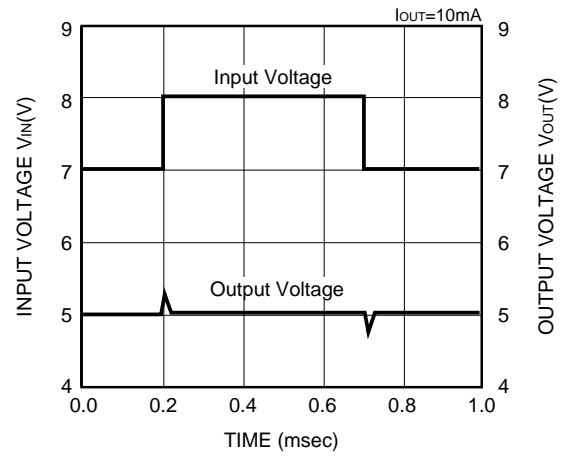

XC62HR5002 (5V)

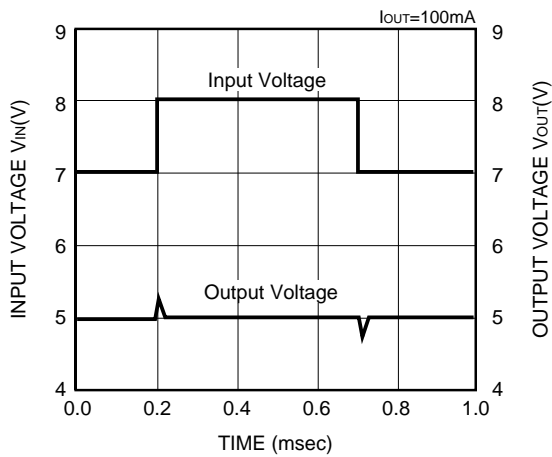

(9) INPUT TRANSIENT RESPONSE 2 (CONTINUED)

XC62HR4002 (4V)

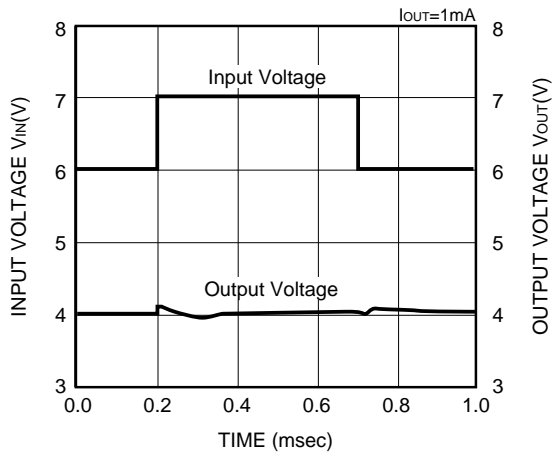

XC62HR4002 (4V)

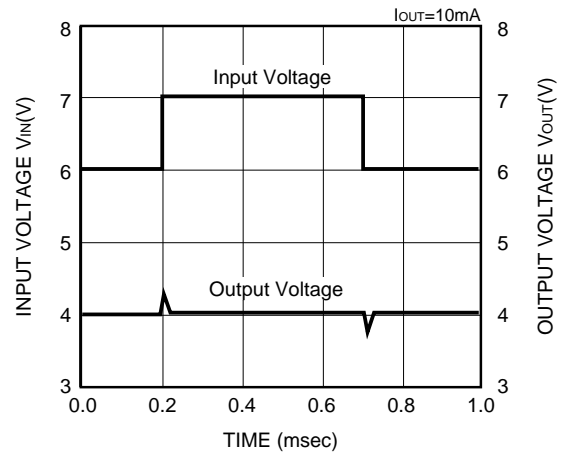

XC62HR4002 (4V)

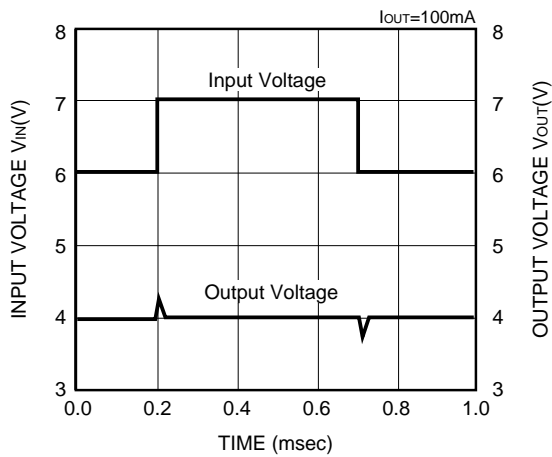

### (9) INPUT TRANSIENT RESPONSE 2 (CONTINUED)

#### XC62HR3002 (3V)

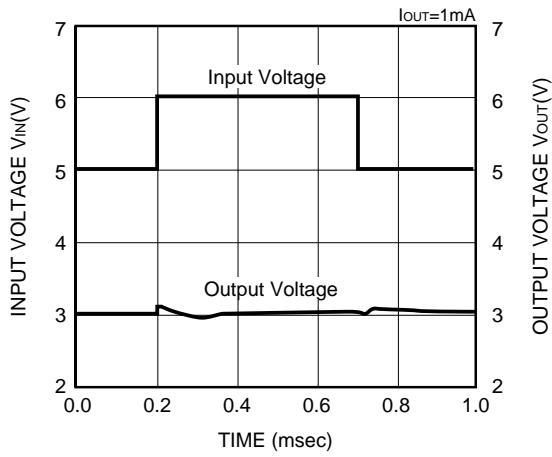

#### XC62HR3002 (3V)

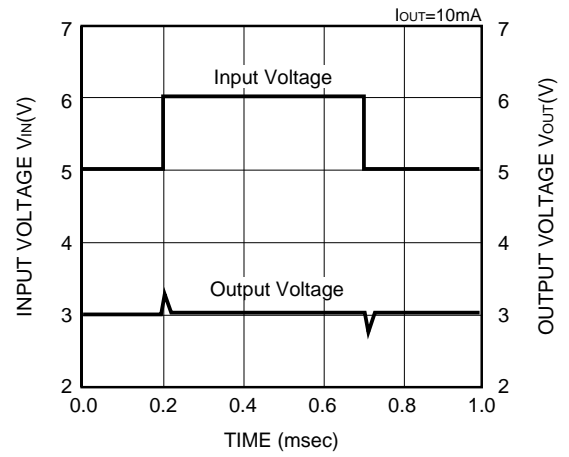

#### XC62HR3002 (3V)

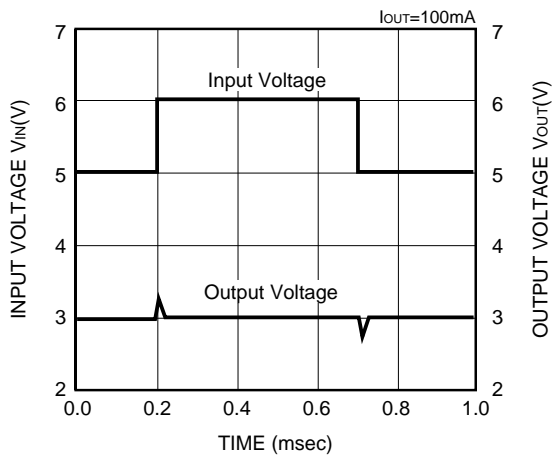



(9) INPUT TRANSIENT RESPONSE 2 (CONTINUED)

XC62HR2002 (2V)

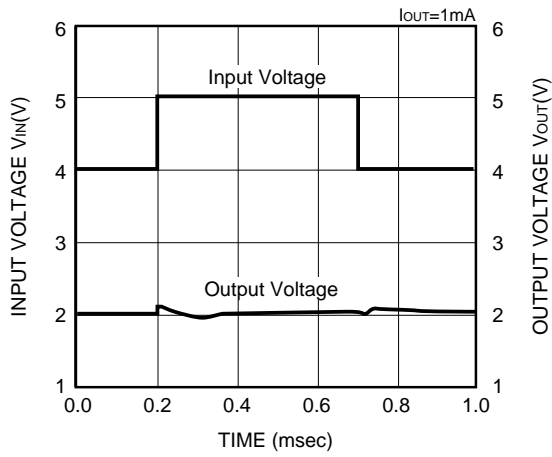

XC62HR2002 (2V)

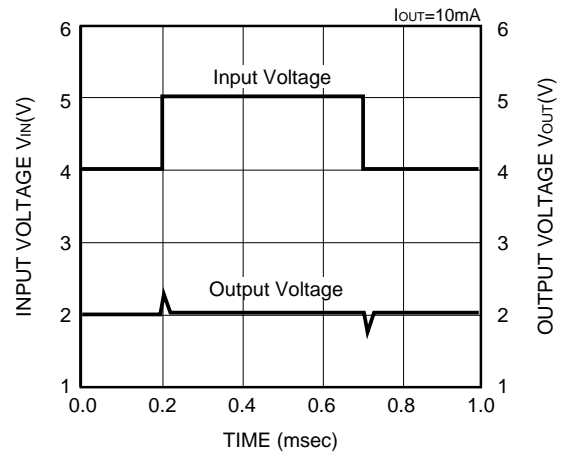

XC62HR2002 (2V)

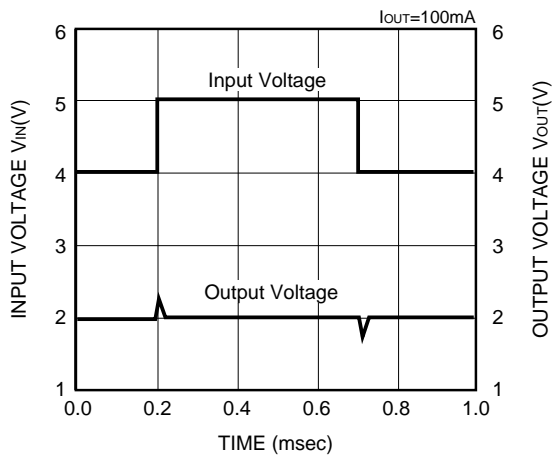

### (10) LOAD TRANSIENT RESPONSE

XC62HR5002 (5V)

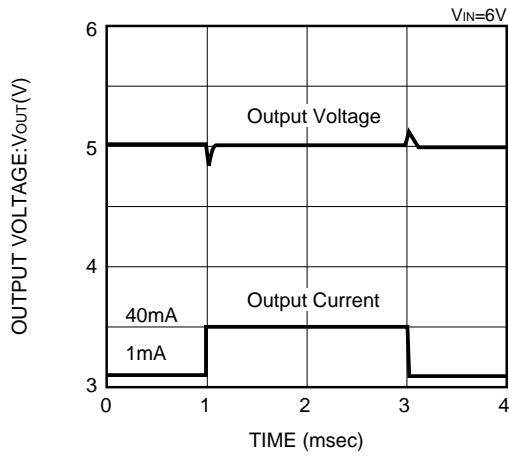

XC62HR5002 (5V)

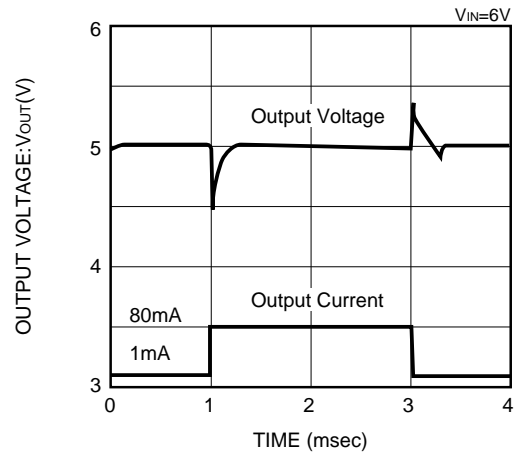

XC62HR4002 (4V)

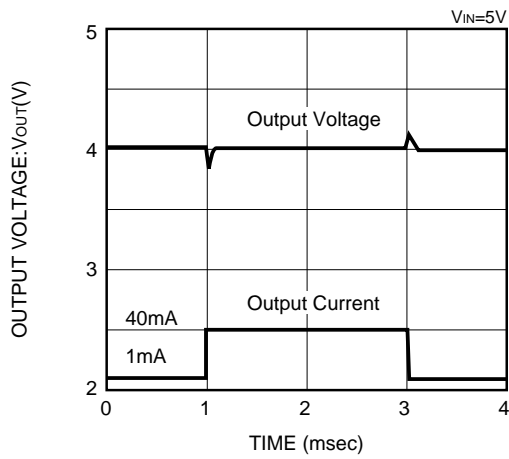

XC62HR4002 (4V)

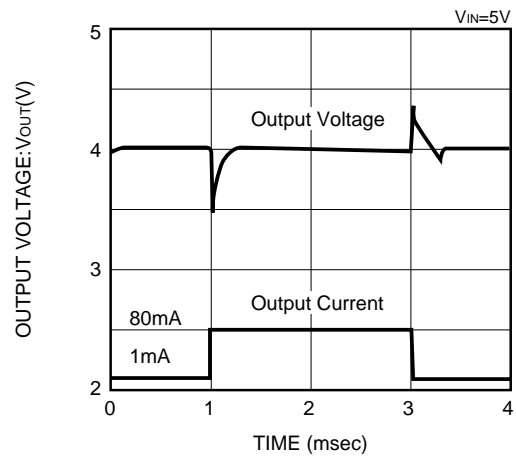

(10) LOAD TRANSIENT RESPONSE (CONTINUED)

XC62HR3002 (3V)

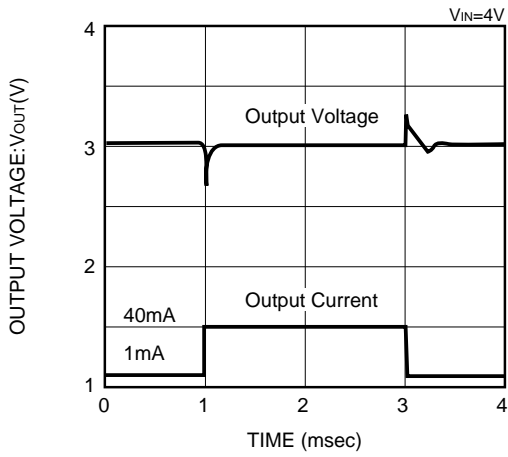

XC62HR3002 (3V)

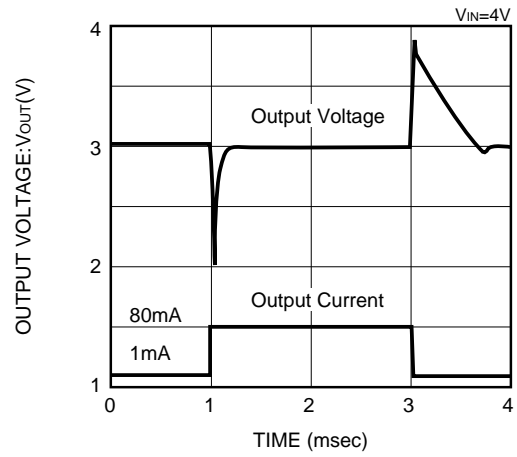

XC62HR2002 (2V)

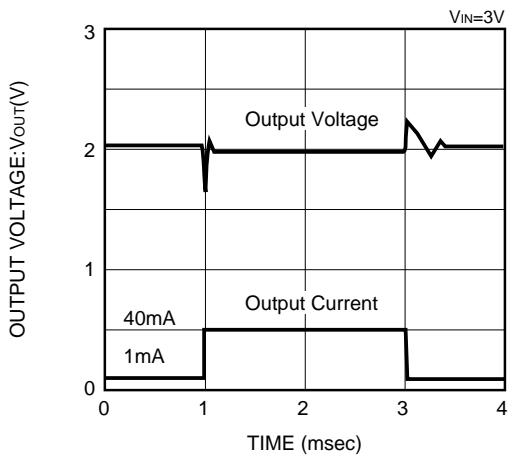

XC62HR2002 (2V)

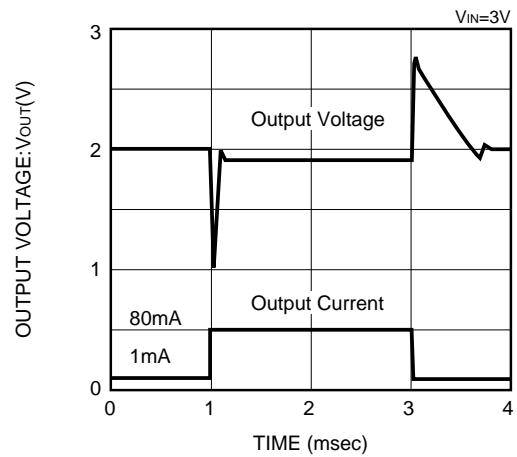

### (11) CE PIN TRANSIENT RESPONSE

XC62HR5002 (5V)

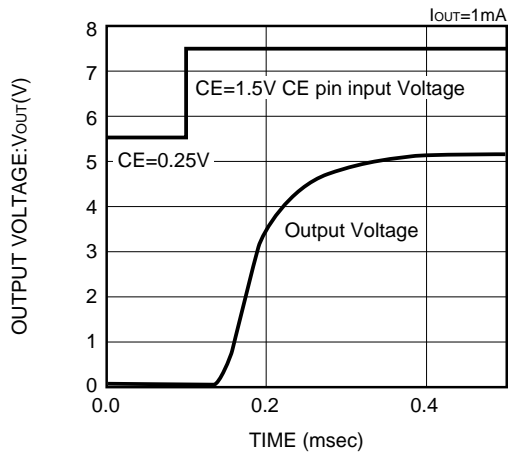

XC62HR5002 (5V)

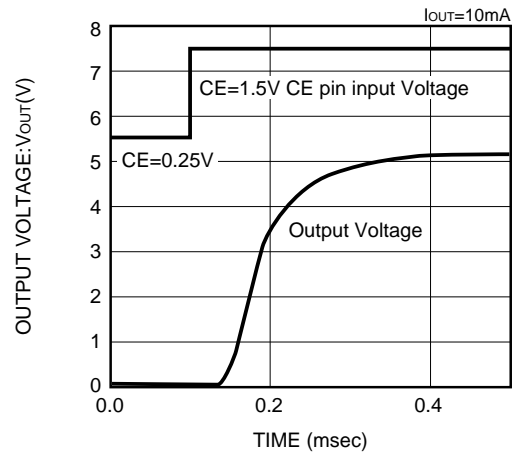

XC62HR5002 (5V)

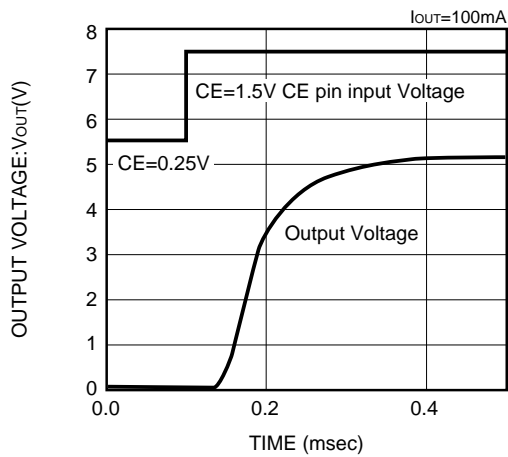

(11) CE PIN TRANSIENT RESPONSE (CONTINUED)

XC62HR4002 (4V)

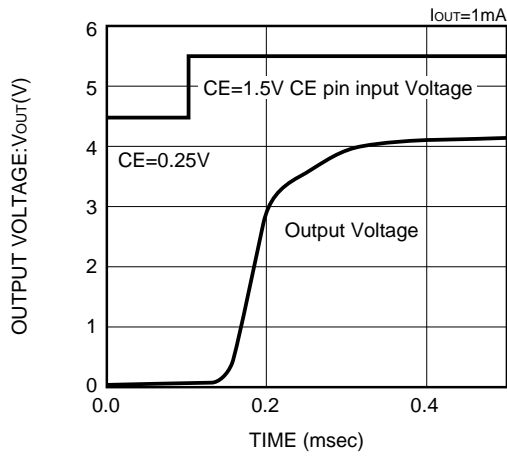

XC62HR4002 (4V)

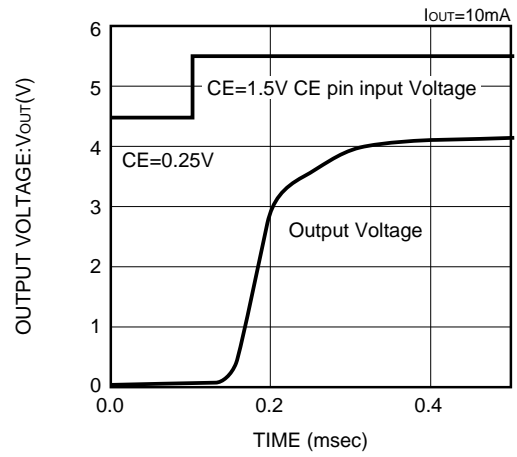

XC62HR4002 (4V)

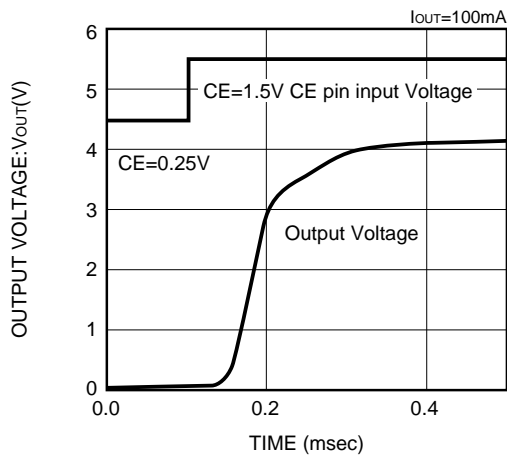

### (11) CE PIN TRANSIENT RESPONSE (CONTINUED)

#### XC62HR3002 (3V)

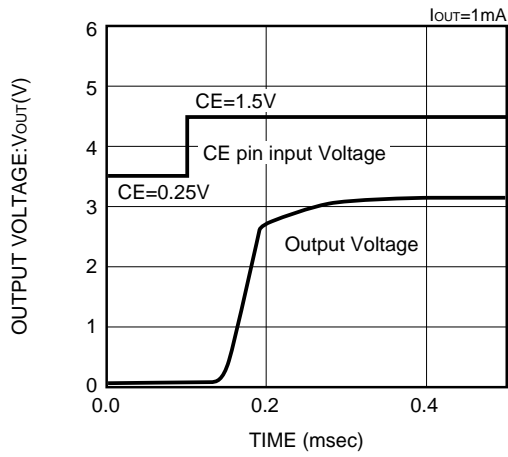

#### XC62HR3002 (3V)

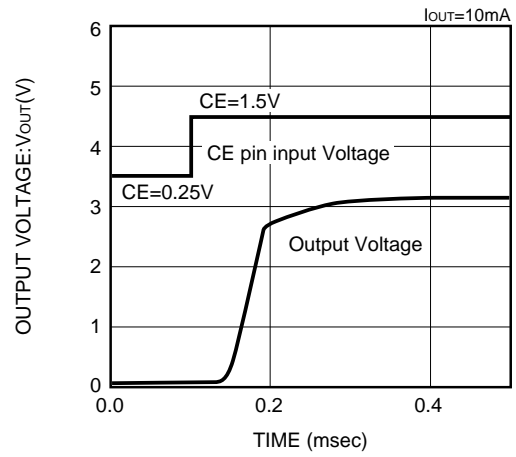

#### XC62HR3002 (3V)

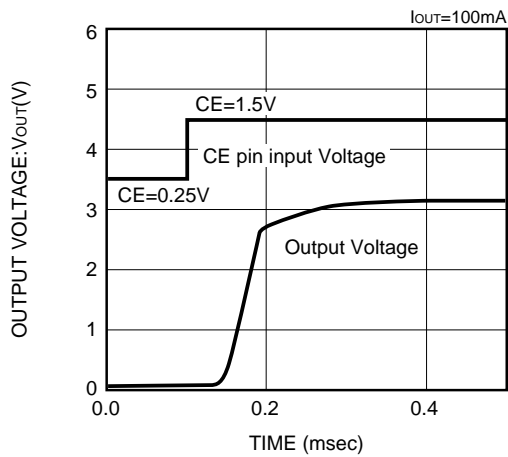

(11) CE PIN TRANSIENT RESPONSE (CONTINUED)

XC62HR2002 (2V)

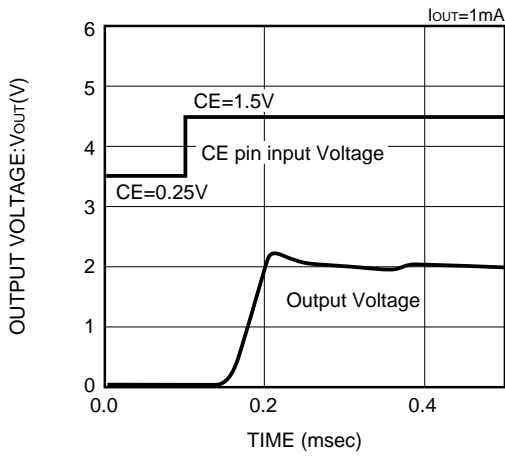

XC62HR2002 (2V)

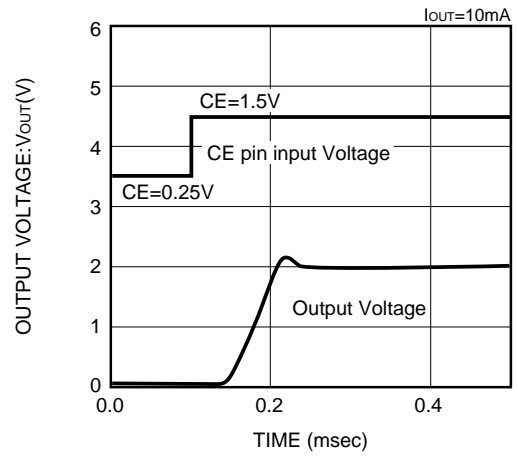

XC62HR2002 (2V)

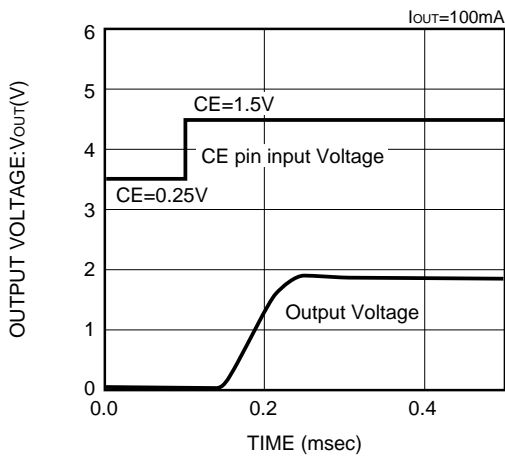

### (12) RIPPLE REJECTION RATE

#### XC62HR5002

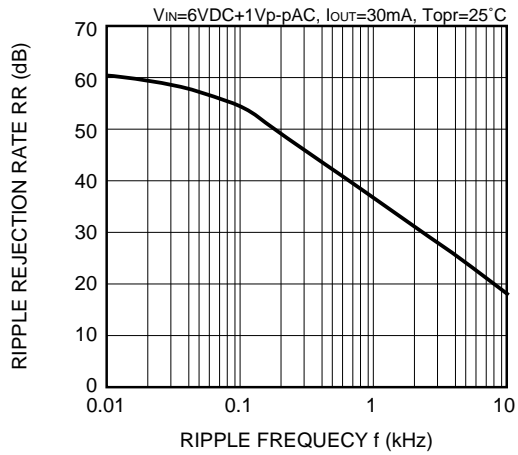

#### XC62HR4002

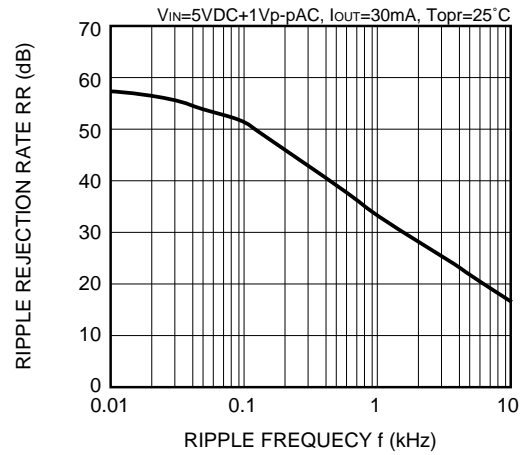

#### XC62HR3002

