

# XB1117 Series

## 1A Low Dropout Positive Voltage Regulator



### Preliminary

- ◆ Bi-polar transistors LDD
- ◆ Output Voltage (1.8V, 2.5V, 3.3V, 5.0V, ADJ)
- ◆ Output Voltage Accuracy :  $\pm 1\%$
- ◆ Output Current : Up to 1A

### APPLICATIONS

- Highly efficient linear regulator
- 5V ~ 3V DC / DC converter
- Battery charger
- Local power supply inside equipment
- Battery powered equipment

### GENERAL DESCRIPTION

The XB1117 series is a 1A low dropout positive voltage regulator. Output voltage of the XB1117P series is fixed to 1.8V, 2.5V, 3.3V, and 5.0V. The XB1117K series' output voltage is adjustable by the external resistors. Please refer to the absolute maximum ratings for the difference between the rated input voltage of the XB1117P50 ( $V_{OUT}=5.0V$ ) and the XB1117P18 / 25 / 30 ( $V_{OUT}=1.8V, 2.5V$  and  $3.0V$ ) and XB1117K type. With the dropout voltage 1.2V (TYP.), output current can be generated up to 1A. The built-in overcurrent circuit and thermal protection circuit start to operate when either one of output put current reaches the current limit level or junction temperature reaches the temperature limit. The XB1117 series provide stable line and load regulation by using an input capacitor ( $10\mu F$ , tantalum) and an output capacitor. Package is available in SOT-223.

### FEATURES

- Low Dropout Voltage** : 1.2V @  $I_{OUT} = 1A$
- Adjustable or Fixed Voltages** : 1.8V, 2.5V, 3.3V, 5.0V (ADJ)
- Line Regulation (TYP.)** : 0.04% (ADJ)
- Load Regulation (TYP.)** : 0.1% (ADJ)
- Adjust pin current less than 120  $\mu A$  (ADJ)**
- Overcurrent protection circuit built-in**
- Thermal protection circuit built-in**
- Package** : SOT-223

### TYPICAL APPLICATION CIRCUIT

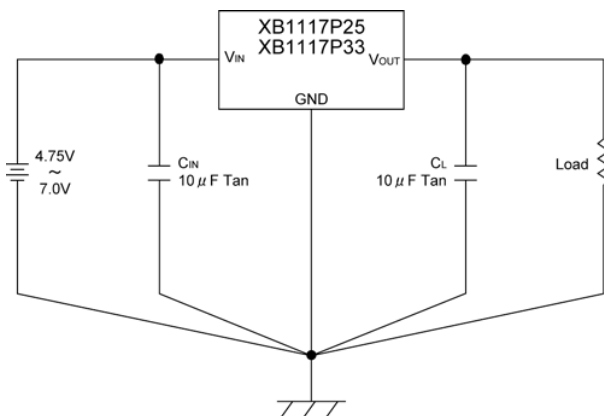

### TYPICAL PERFORMANCE CHARACTERISTICS

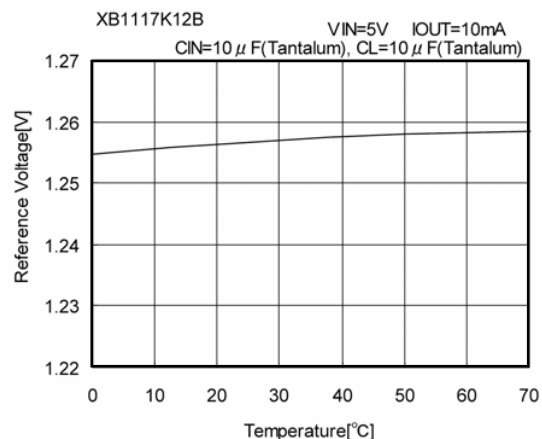

## ■ PIN CONFIGURATION

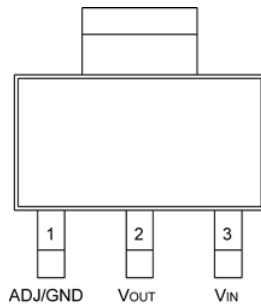

## ■ PIN ASSIGNMENT

PIN	PIN NAME	FUNCTION
1	ADJ/GND	ADJ/Ground
2	VOUT	Output
3	VIN	Power Input

## ■ PRODUCT CLASSIFICATION

### ● Ordering Information

XB1117①②③④⑤⑥

DESIGNATOR	DESCRIPTION	SYMBOL	DESCRIPTION
①	Type of Regulator	P	: Fixed VOUT type
		K	: Adjustable VOUT type
②③④	Output Voltage & Accuracy	181	: Fixed VOUT 1.80V ( $\pm 1\%$ )
		251	: Fixed VOUT 2.50V ( $\pm 1\%$ )
		331	: Fixed VOUT 3.30V ( $\pm 1\%$ )
		501	: Fixed VOUT 5.00V ( $\pm 1\%$ )
		12B	: Adjustable VOUT 1.25V ( $\pm 1\%$ )
⑤	Package	F	: SOT-223
⑥	Device Orientation	R	: Embossed tape, Standard feed
		L	: Embossed tape, Reverse feed

## ■ PACKAGING INFORMATION

### ● SOT-223

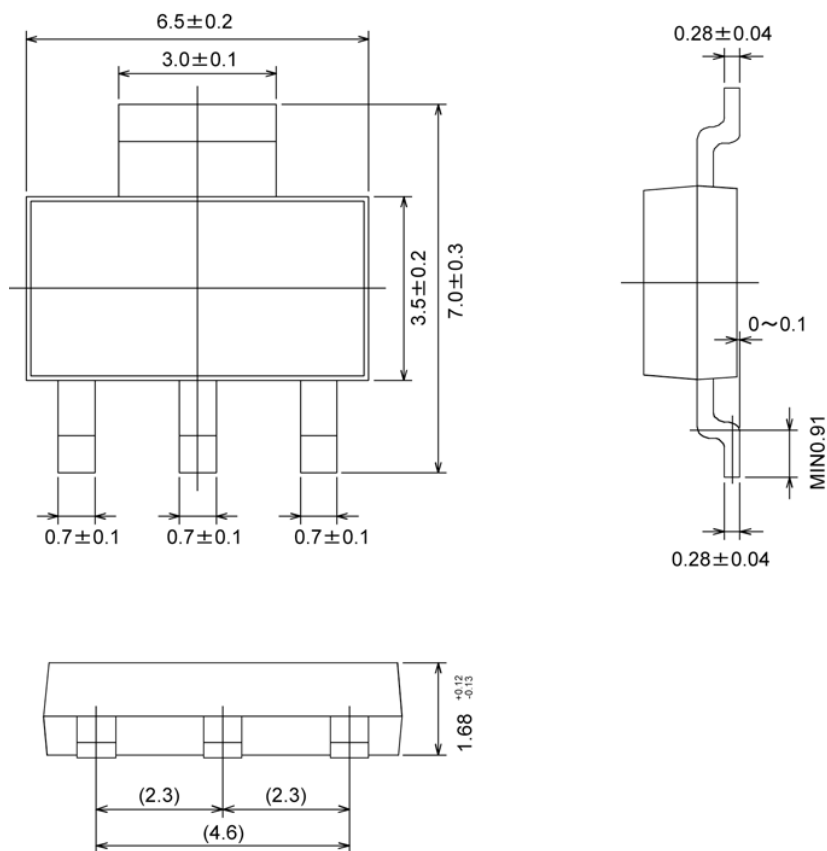

## ■ BLOCK DIAGRAM

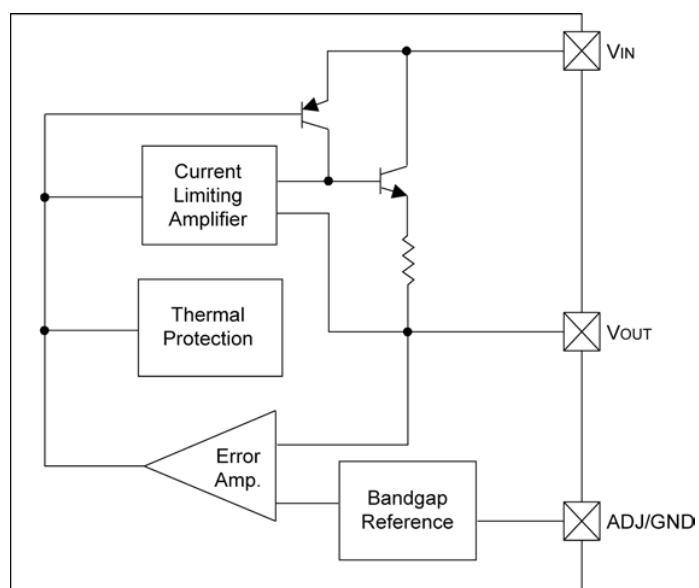

## ■ ABSOLUTE MAXIMUM RATINGS

XB1117P50

PARAMETER	SYMBOL	RATINGS	UNITS
Input Voltage	V <sub>IN</sub>	10.0	V
Thermal Resistance (Junction to Case)	$\theta_{JC}$	15	°C/W
Thermal Resistance (Junction to Ambient)	$\theta_{JA}$	160	
Power Dissipation ( $\Delta T=100^{\circ}\text{C}$ )	PD	625	mW
Operating Temperature Range	TOPR	0 ~ +70	°C
Operating Junction Temperature Range	T <sub>J</sub>	0 ~ +125	
Storage Temperature Range	T <sub>STG</sub>	-65 ~ +150	
Lead Temperature	T <sub>LEAD</sub>	260	

\*Stress above the listed absolute maximum rating may cause permanent damage to the device.

\*\* Please note that the difference between the rated input voltage of the XB1117P50 (V<sub>OUT</sub>=5.0V) and the XB1117P18 / 25 / 30 (V<sub>OUT</sub>=1.8V, 2.5V and 3.0V) and XB1117K type.

## ■ ELECTRICAL CHARACTERISTICS

XB1117P501

T<sub>a</sub>=25°C

PARAMETER	SYMBOL	CONDITIONS	STANDARD VALUE			UNITS
			MIN.	TYP.	MAX.	
Output Voltage	V <sub>OUT</sub>	V <sub>IN</sub> =7.0V I <sub>OUT</sub> =0A *Over Temp.	4.950 4.900	5.000 5.000	5.050 5.100	V
Line Regulation	$\Delta V_{OUT1}$	7.0V ≤ V <sub>IN</sub> ≤ 9.0V I <sub>OUT</sub> =0A *Over Temp.	-	1	6	mV
Load Regulation	$\Delta V_{OUT2}$	V <sub>IN</sub> =7.0V 0A ≤ I <sub>OUT</sub> ≤ 1.0A *Over Temp.	-	5.0 10.1	15.2 20.2	
Dropout Voltage	V <sub>dif</sub>	$\Delta V_{OUT} = \pm 1\%$ 0A ≤ I <sub>OUT</sub> ≤ 1.0A *Over Temp.	-	1.2 1.3	1.4 -	V
Current Limit	I <sub>lim</sub>	7.0V ≤ V <sub>IN</sub> ≤ 10.0V *Over Temp.	1.0	1.5	-	A
Supply Current	I <sub>SS</sub>	V <sub>IN</sub> =7.0V 0A ≤ I <sub>OUT</sub> ≤ 1.0A *Over Temp.	-	6	13	mA
Temperature Coefficient	T <sub>C</sub>	7.0V ≤ V <sub>IN</sub> ≤ 10.0V 0A ≤ I <sub>OUT</sub> ≤ 1.0A	-	50	-	ppm/°C
Temperature Stability	T <sub>S</sub>	V <sub>IN</sub> =7.0V I <sub>OUT</sub> =100mA *Over Temp.	-	0.5	-	%

\*Over Temp. = Over Temperature (0 ~ +70°C)

**■ ABSOLUTE MAXIMUM RATINGS** (XB1117P18, P25, P33, K)

PARAMETER	SYMBOL	RATINGS	UNITS
Input Voltage	V <sub>IN</sub>	7.0	V
Thermal Resistance (Junction to Case)	$\theta_{JC}$	15	°C/W
Thermal Resistance (Junction to Ambient)	$\theta_{JA}$	160	
Power Dissipation ( $\Delta T=100^{\circ}\text{C}$ )	P <sub>D</sub>	625	mW
Operating Temperature Range	T <sub>OPR</sub>	0 ~ 70	°C
Operating Temperature Range	T <sub>J</sub>	0 ~ 125	
Storage Temperature Range	T <sub>STG</sub>	-65 ~ 150	
Lead Temperature	T <sub>LEAD</sub>	260	

\*Stress above the listed absolute maximum rating may cause permanent damage to the device.

**■ ELECTRICAL CHARACTERISTICS**

XB1117P181

 T<sub>J</sub>=25°C

PARAMETER	SYMBOL	CONDITIONS	STANDARD VALUE			UNITS
			MIN.	TYP.	MAX.	
Output Voltage	V <sub>OUT</sub>	V <sub>IN</sub> =5.0V I <sub>OUT</sub> =0A	1.782	1.800	1.818	V
		*Over Temp.	1.764	1.800	1.836	
Line Regulation	$\Delta V_{OUT1}$	4.75V ≤ V <sub>IN</sub> ≤ 7.0V I <sub>OUT</sub> = 0A	-	1.0	6.8	mV
Load Regulation	$\Delta V_{OUT2}$	V <sub>IN</sub> =5.0V 0A ≤ I <sub>OUT</sub> ≤ 1.0A	-	1.80	18.2	mV
		*Over Temp.	-	3.70	22.0	
Dropout Voltage	V <sub>dif</sub>	$\Delta V_{OUT} = \pm 1\%$ 0A ≤ I <sub>OUT</sub> ≤ 1.0A	-	1.2	1.4	V
		*Over Temp.	-	1.3	-	
Current Limit	I <sub>lim</sub>	4.75V ≤ V <sub>IN</sub> ≤ 7.0V	1.0	1.5	-	A
Supply Current	I <sub>SS</sub>	V <sub>IN</sub> =5.0V 0A ≤ I <sub>OUT</sub> ≤ 1.0A	-	6	13	mA
Temperature Coefficient	T <sub>C</sub>	4.75V ≤ V <sub>IN</sub> ≤ 7.0V 0A ≤ I <sub>OUT</sub> ≤ 1.0A	-	50	-	ppm/°C
Temperature Stability	T <sub>S</sub>	V <sub>IN</sub> =5.0V I <sub>OUT</sub> =100mA	-	0.5	-	%

\*Over Temp. = Over Temperature (0 ~ +70°C)

XB1117P251

 T<sub>J</sub>=25°C

PARAMETER	SYMBOL	CONDITIONS	STANDARD VALUE			UNITS
			MIN.	TYP.	MAX.	
Output Voltage	V <sub>OUT</sub>	V <sub>IN</sub> =5.0V I <sub>OUT</sub> =0A	2.475	2.500	2.525	V
		*Over Temp.	2.450	2.500	2.550	
Line Regulation	$\Delta V_{OUT1}$	4.75V ≤ V <sub>IN</sub> ≤ 7.0V I <sub>OUT</sub> =0A	-	1.0	6.8	mV
Load Regulation	$\Delta V_{OUT2}$	V <sub>IN</sub> =5.0V 0A ≤ I <sub>OUT</sub> ≤ 1.0A	-	2.5	25.3	mV
		*Over Temp.	-	5.1	30.3	
Dropout Voltage	V <sub>dif</sub>	$\Delta V_{OUT} = \pm 1\%$ 0A ≤ I <sub>OUT</sub> ≤ 1.0A	-	1.2	1.4	V
		*Over Temp.	-	1.3	-	
Current Limit	I <sub>lim</sub>	4.75V ≤ V <sub>IN</sub> ≤ 7.0V	1.0	1.5	-	A
Supply Current	I <sub>SS</sub>	V <sub>IN</sub> =5.0V 0A ≤ I <sub>OUT</sub> ≤ 1.0A	-	6	13	mA
Temperature Coefficient	T <sub>C</sub>	4.75V ≤ V <sub>IN</sub> ≤ 7.0V 0A ≤ I <sub>OUT</sub> ≤ 1.0A	-	50	-	ppm/°C
Temperature Stability	T <sub>S</sub>	V <sub>IN</sub> =5.0V I <sub>OUT</sub> =100mA	-	0.5	-	%

\*Over Temp. = Over Temperature (0 ~ +70°C)

## ■ ELECTRICAL CHARACTERISTICS (Continued)

XB1117P331

T<sub>J</sub> = 25°C

PARAMETER	SYMBOL	CONDITIONS	STANDARD VALUE			UNITS
			MIN.	TYP.	MAX.	
Output Voltage	V <sub>OUT</sub>	V <sub>IN</sub> =5.0V I <sub>OUT</sub> =0A	3.267	3.300	3.333	V
		*Over Temp.	3.234	3.300	3.366	
Line Regulation	ΔV <sub>OUT1</sub>	4.75V ≤ V <sub>IN</sub> ≤ 7.0V I <sub>OUT</sub> =0A	-	1.0	4.5	mV
Load Regulation	ΔV <sub>OUT2</sub>	V <sub>IN</sub> =5.0V 0A ≤ I <sub>OUT</sub> ≤ 1.0A	-	3.4	10.0	
Dropout Voltage	V <sub>dif</sub>	ΔV <sub>OUT</sub> = ± 1% 0A ≤ I <sub>OUT</sub> ≤ 1.0A	-	1.2	1.4	V
		*Over Temp.	-	1.3	-	
Current Limit	I <sub>lim</sub>	4.75V ≤ V <sub>IN</sub> ≤ 7.0V	1.0	1.5	-	A
Supply Current	I <sub>SS</sub>	V <sub>IN</sub> =5.0V 0A ≤ I <sub>OUT</sub> ≤ 1.0A	-	6	13	mA
Temperature Coefficient	T <sub>C</sub>	4.75V ≤ V <sub>IN</sub> ≤ 7.0V 0A ≤ I <sub>OUT</sub> ≤ 1.0A	-	50	-	ppm/°C
Temperature Stability	T <sub>S</sub>	V <sub>IN</sub> =5.0V I <sub>OUT</sub> =100mA	-	0.5	-	%

\*Over Temp. = Over Temperature (0 ~ +70°C)

XB1117K12B

T<sub>a</sub> = 25°C

PARAMETER	SYMBOL	CONDITIONS	STANDARD VALUE			UNITS
			MIN.	TYP.	MAX.	
Reference voltage	V <sub>ref</sub>	V <sub>IN</sub> =5.0V I <sub>OUT</sub> =10mA	1.238	1.250	1.262	V
		*Over Temp.	1.225	1.250	1.275	
Line Regulation	ΔV <sub>OUT1</sub>	4.75V ≤ V <sub>IN</sub> ≤ 7.0V I <sub>OUT</sub> =0A	-	0.04	0.20	%
Load Regulation	ΔV <sub>OUT2</sub>	V <sub>IN</sub> =5.0V 10mA ≤ I <sub>OUT</sub> ≤ 1.0A	-	0.1	0.3	%
		*Over Temp.	-	0.2	0.4	
Dropout Voltage	V <sub>dif</sub>	ΔV <sub>OUT</sub> = ± 1% 10mA ≤ I <sub>OUT</sub> ≤ 1.0A	-	1.2	1.4	V
		*Over Temp.	-	1.3	-	
Current Limit	I <sub>lim</sub>	2.75A ≤ V <sub>IN</sub> ≤ 7.0V	1.0	1.5	-	A
Temperature Coefficient	T <sub>C</sub>	2.75V ≤ V <sub>IN</sub> ≤ 7.0V 10mA ≤ I <sub>OUT</sub> ≤ 1.0A	-	50	-	ppm/°C
Adjust Pin Current	I <sub>ADJ</sub>	2.75V ≤ V <sub>IN</sub> ≤ 7.0V 10mA ≤ I <sub>OUT</sub> ≤ 1.0A	-	55	-	μA
		*Over Temp.	-	-	120	
Adjust Pin Current Change	ΔI <sub>ADJ</sub>	2.75V ≤ V <sub>IN</sub> ≤ 7.0V 10mA ≤ I <sub>OUT</sub> ≤ 1.0A	-	0.2	5.0	μA
Temperature Stability	T <sub>S</sub>	V <sub>IN</sub> =5.0V I <sub>OUT</sub> =100mA	-	0.5	-	%
Minimum Load Current	I <sub>OUT</sub>	V <sub>OUT</sub> =5.0V	-	-	10	mA

\*Over Temp. = Over Temperature (0 ~ +70°C)

## ■ OPERATIONAL EXPLANATION

### 1. Output voltage adjustment

The XB1117 series provides a stable output by comparing the output voltage to an internal reference voltage. With the adjustable XB1117K type, a 1.25V reference voltage ( $V_{REF}$ ) is set between the VOUT pin and the ADJ pin and the external resistors R1 and R2 are used to set the output voltage. The resistance values of R1 and R2 should be set so as to provide a minimum load current of 10mA. The output voltage is given by the following equation.

$$V_{OUT} = V_{REF}(1 + R_2/R_1) + I_{ADJ} \times R_2$$

The output voltage of the XB1117P type is internally fixed to 1.8V, 2.5V, 3.3V, and 5.0V so external resistors are not necessary.

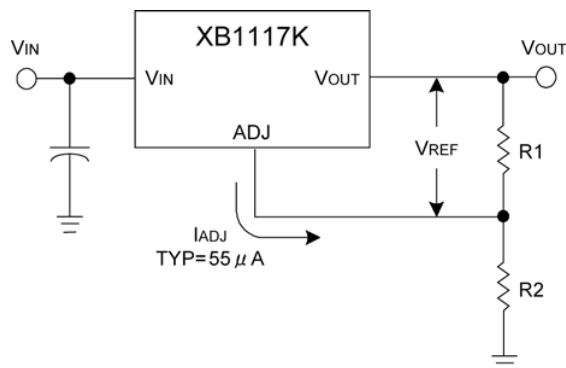

### 2. Stability and load regulation

The XB1117 series requires a load capacitor between the VOUT pin and the GND pin to provide phase compensation thereby ensuring stability of the output voltage. Either a tantalum capacitor of more than 10 μF (TYP.) or an aluminum electrolytic capacitor of more than 50 μF (TYP.) should be connected.

(Note : The capacitor's ESR value should not exceed 0.5 Ω.)

The output capacitor does not have a theoretical upper limit so increasing its value will increase stability.  $C_L = 100 \mu F$  or more is typical for high current regulator design.

In order to avoid any reductions in output voltage accuracy with the XB1117K type, we recommend that you do not place a parasitic resistor ( $R_p$ ) between the VOUT pin and the divider resistor R1. The parasitic resistor ( $R_p$ ) does not influence the output however if the divider resistor R1 is directly connected to the VOUT pin.

With the XB1117P type, although external resistor (R1) is internally connected to the VOUT pin, stability can be maintained by not wiring a parasitic resistor to the GND pin.

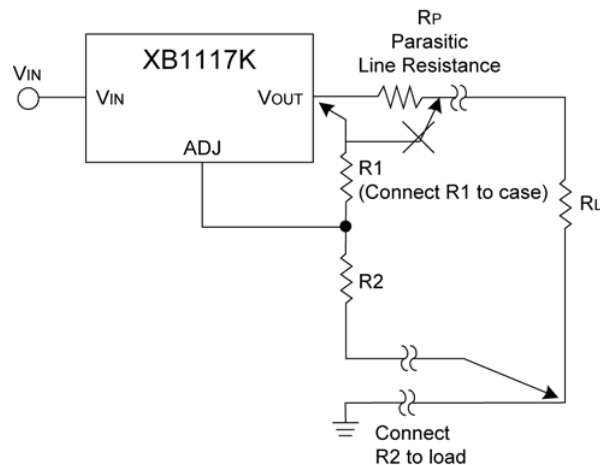

### 3. Thermal protection

XB1117 series has thermal protection which limits junction temperature to 150°C. However, device functionally is only guaranteed to a maximum junction temperature of + 125°C. The power dissipation and junction temperature for XB1117 in DPAK package are given by

$$P_D = (V_{IN} - V_{OUT}) \times I_{OUT}$$

$$T_{JUNCTION} = T_{AMBIENT} + (P_D \times \theta_{JA})$$

NOTE : T JUNCTION must not exceed 125°C.

## ■ OPERATIONAL EXPLANATION (Continued)

### 4. Current limit protection

XB1117 series is protected against overload conditions. Current protection is triggered at 1.5A (TYP.).

### 5. Thermal consideration

The XB1117 series contain thermal limiting circuitry designed to protect itself from over-temperature conditions. Even for normal load conditions, maximum junction temperature ratings must not be exceeded. As mentioned in thermal protection section, we need to consider all sources of thermal resistance between junction and ambient. It includes junction-to-case, case-to-heat-sink interface and heat sink thermal resistance itself.

Junction-to-case thermal resistance is specified from the IC junction to the bottom of the case directly below the die. Proper mounting is required to ensure the best possible thermal flow from this area of the package to the heat sink. The case of all devices in this product series is electrically connected to the output. Therefore, if the case of the device must be electrically isolated, a thermally conductive spacer is recommended.

## ■ APPLICATION CIRCUITS

### Adjustable Output Voltage

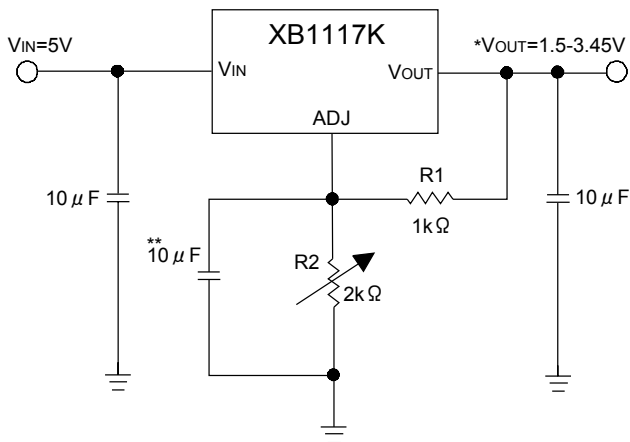

Note:  $*V_{OUT} = V_{REF} \left(1 + \frac{R2}{R1}\right) + I_{ADJ} \times R2$

\*\*Optional for improved ripple rejection



## ■ APPLICATION CIRCUITS (Continued)

Regulator with reference voltage

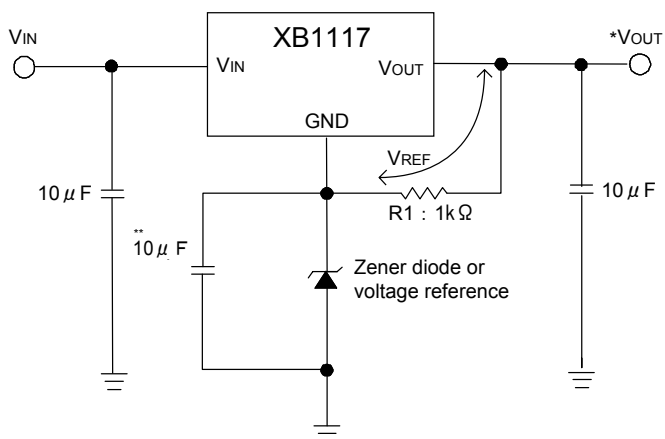

Note: \*Vout = VREF + Vz (Vz: Breakdown voltage of Zener diode)  
 \*\* Optional for improved ripple rejection

Regulator with reverse diode protection

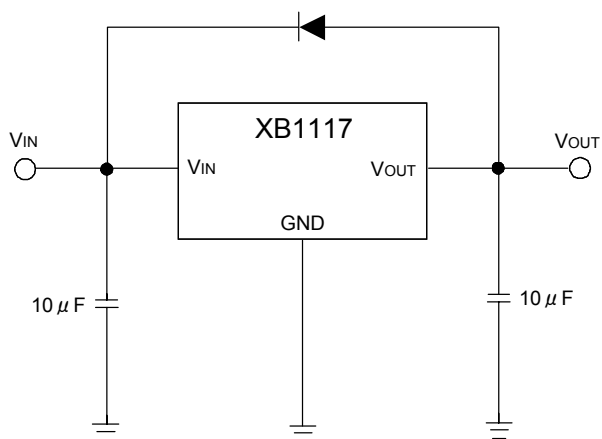

## TYPICAL PERFORMANCE CHARACTERISTICS

(1) Load Stability— Ambient Temperature

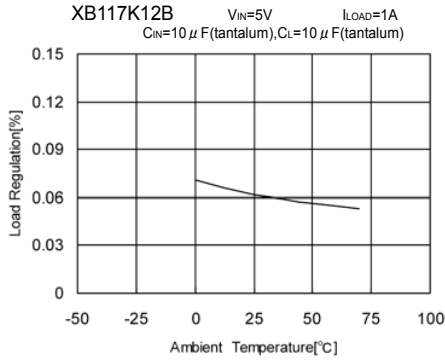

(2) Reference Voltage— Ambient Temperature

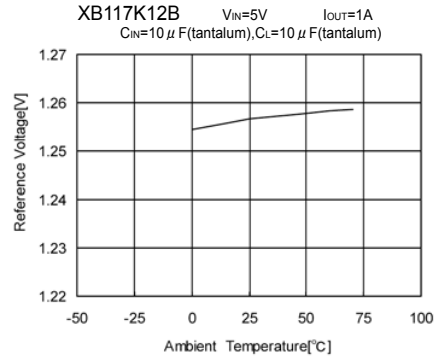

(3) Output Short Circuit Current— Dropout Voltage

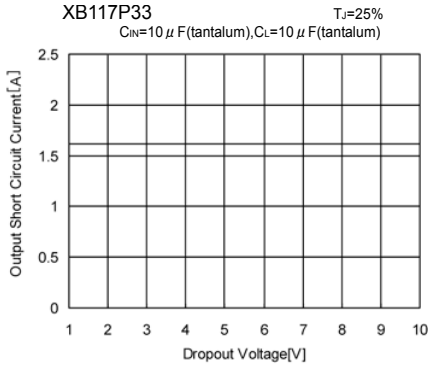

(4) Dropout Voltage— Output Current

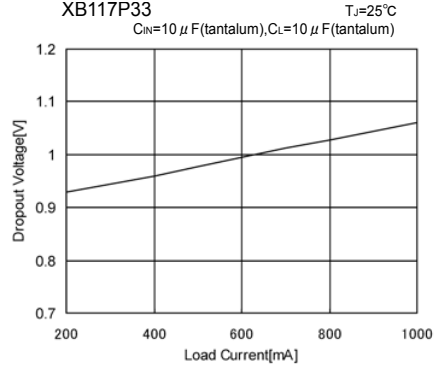

(5) Adjust Pin Current— Ambient Temperature

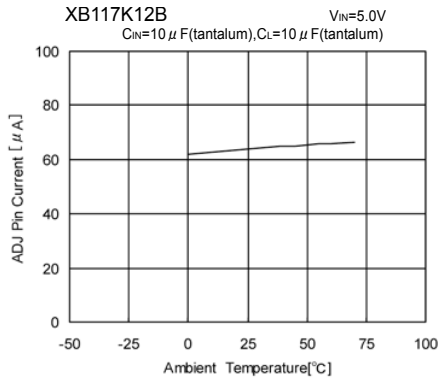

(6) Supply Current— Dropout Voltage

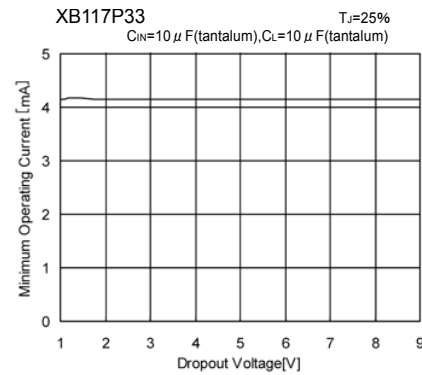

(7) Load Transient Response

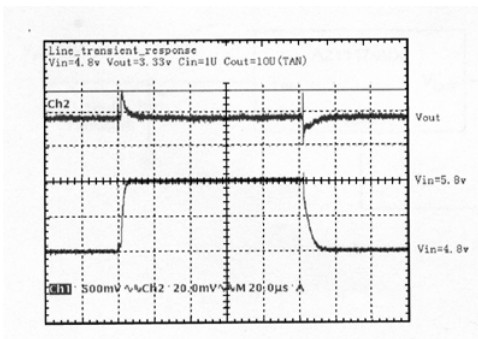

(8) Input Transient Response

