



SMT inductors

SIMID series, SIMID 0805-B

Series/Type: **B82498B**
Date: **March 2008**

© EPCOS AG 2008. Reproduction, publication and dissemination of this publication, enclosures hereto and the information contained therein without EPCOS' prior express consent is prohibited.

SMD

Size 0805 (EIA) and/or 2012 (IEC)
Rated inductance 2.7 nH to 4700 nH
Rated current 90 mA to 1000 mA

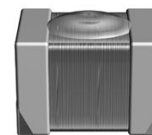

Construction

- Cubic coil with ceramic core
- Winding partially plastic-sealed
- Winding ends welded to terminals

Features

- High Q factor
- High resonance frequency
- Close inductance tolerance
- Suitable for lead-free reflow soldering
- RoHS-compatible

Applications

Resonant circuits, impedance matching for

- Antenna amplifiers
- Multimedia
- Car access systems
- TPMS (Tire Pressure Monitoring System)
- Wireless communication systems
- GPS (Global Positioning System)

Terminals

- Base material Al₂O₃ ceramic or ferrite
- Thick-film coating of Ag/Pd/Pt

Marking

- No marking on component
- Minimum data on reel:
Manufacturer, ordering code, L value,
quantity, date of packing

Delivery mode and packing unit

- 8-mm blister tape, wound on 180-mm Ø reel
- Packing unit: 3000 pcs./reel

SMD

Dimensional drawing and layout recommendation

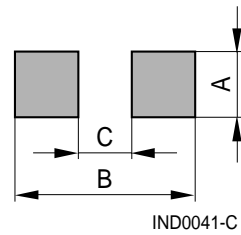
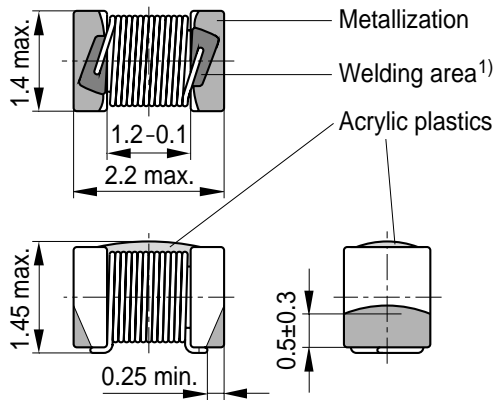

IND0041-C

A	B	C
1.1 ±0.2	3.4 ±0.4	1.1 ±0.1

1) This area (30% of contact area) should not be used to assess solderability

IND0047-U-E

Dimensions in mm

Taping and packing

Blister tape

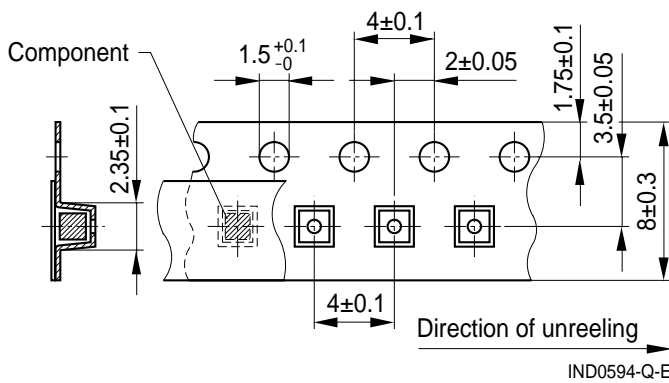

IND0594-Q-E

Dimensions in mm

Reel

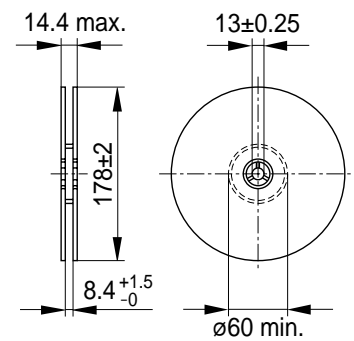

IND0581-C

SMD
Technical data and measuring conditions

Rated inductance L_R	Measured with RF LCR meter Agilent 4286A and test fixture Agilent 16193A at frequency f_L , 0.1 V, 20 °C
Q factor Q_{min} , Q_{typ}	Measured with RF LCR meter Agilent 4286A and test fixture Agilent 16193A, 20 °C Q_{min} measured at frequency f_Q
Rated temperature T_R	85 °C
Rated current I_R	Maximum permissible DC with inductance decrease $\Delta L/L_0 \leq 10\%$ and temperature increase of ≤ 20 K at rated temperature
Self-resonance frequency $f_{res,min}$	Measured with network analyzer Agilent 8753D, 20 °C
DC resistance R_{max}	Measured at 20 °C
Solderability (lead-free)	Sn95.5Ag3.8Cu0.7: (245 ±5) °C, (5 ±0.3) s Wetting of soldering area $\geq 90\%$ (based on IEC 60068-2-58)
Resistance to soldering heat	260 °C, 20 s (as referenced in JEDEC J-STD 020C)
Climatic category	55/125/56 (to IEC 60068-1)
Storage conditions	Mounted: -55 °C ... +125 °C Packaged: -25 °C ... +40 °C, $\leq 75\%$ RH
Weight	Approx. 8.5 mg

Characteristics and ordering codes

L_R	Tolerance	Q_{min}	Q_{typ} (at 800 MHz)	f_L ; f_Q	I_R	R_{max}	$f_{res,min}$	Ordering code
nH				MHz	mA	Ω	MHz	
Core material: ceramic								
2.7	$\pm 10\% \triangleq K$	20	50	250	1000	0.03	6000	B82498B3279M000
5.6	$\pm 20\% \triangleq M$	25	60	250	900	0.04	6000	B82498B3569M000
6.8		30	70	250	800	0.05	5500	B82498B3689K000
8.2		35	75	250	700	0.06	5000	B82498B3829M000
10	$\pm 5\% \triangleq J$	40	80	250	700	0.06	4500	B82498B3100J000
12		40	85	250	700	0.06	4000	B82498B3120J000
15		40	85	250	670	0.07	3500	B82498B3150J000
18		45	90	250	670	0.07	3300	B82498B3180J000
22		45	85	250	600	0.09	2600	B82498B3220J000
27		50	90	250	600	0.09	2500	B82498B3270J000

Closer tolerances on request.

SMD
Characteristics and ordering codes

L_R	Tolerance	Q_{min}	Q_{typ} (at 800 MHz)	$f_L; f_Q$	I_R	R_{max}	$f_{res,min}$	Ordering code ¹⁾
nH				MHz	mA	Ω	MHz	

Core material: ceramic

33	$\pm 5\% \triangle J$	45	80	250	520	0.12	2150	B82498B3330J000
39		50	90	250	560	0.10	2050	B82498B3390J000
47		45	85	200	500	0.13	1900	B82498B3470J000
56	$\pm 2\% \triangle G$	45	60	200	480	0.14	1700	B82498B3560+000
68	$\pm 5\% \triangle J$	45	60	200	410	0.19	1550	B82498B3680+000
82		40	60	150	390	0.21	1430	B82498B3820+000
100		40	50	150	350	0.26	1310	B82498B3101+000
120		40	45	150	270	0.44	1210	B82498B3121+000
150		35	40	100	270	0.44	1120	B82498B3151+000
180		35	30	100	260	0.47	1030	B82498B3181+000
220		35	—	100	240	0.55	950	B82498B3221+000
270		35	—	100	180	1.0	870	B82498B3271+000
330		35	—	100	180	1.0	800	B82498B3331+000
390		35	—	100	130	1.9	730	B82498B3391+000
470		35	—	100	115	2.4	660	B82498B3471+000
560		35	—	100	100	3.2	600	B82498B3561+000

Core material: ferrite

680	$\pm 2\% \triangle G$	20	—	25.2	250	0.50	450	B82498B1681+000
820	$\pm 5\% \triangle J$	20	—	25.2	240	0.55	400	B82498B1821+000
1000		20	—	7.96	250	0.50	350	B82498B1102+000
1200		20	—	7.96	220	0.65	300	B82498B1122+000
1500		20	—	7.96	200	0.75	250	B82498B1152+000
1800		20	—	7.96	190	0.85	250	B82498B1182+000
2200		20	—	7.96	130	1.7	200	B82498B1222+000
2700		20	—	7.96	120	2.0	200	B82498B1272+000
3300		20	—	7.96	100	3.3	200	B82498B1332+000
3900		20	—	7.96	95	3.6	150	B82498B1392+000
4700		20	—	7.96	90	3.8	150	B82498B1472+000

Closer tolerances on request.

1) Replace the + by the code letter for the required inductance tolerance.

SMD

Q factor versus frequency f (ceramic core)

measured with RF LCR meter
Agilent 4286A, typical values at 20 °C

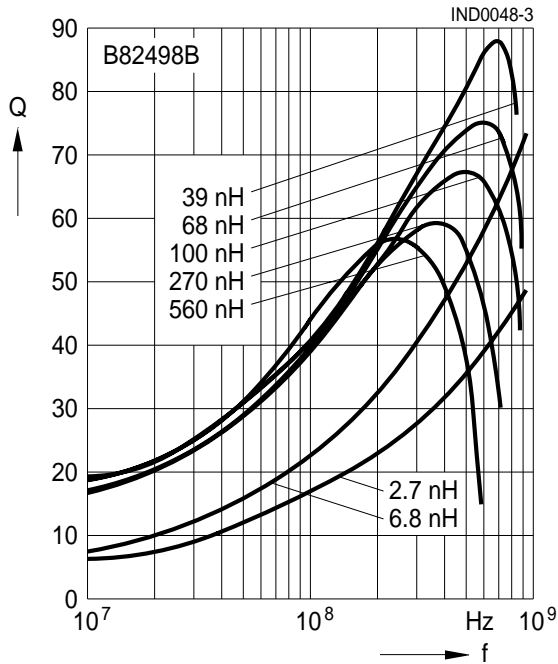

Q factor versus frequency f (ferrite core)

measured with RF LCR meter
Agilent 4286A, typical values at 20 °C

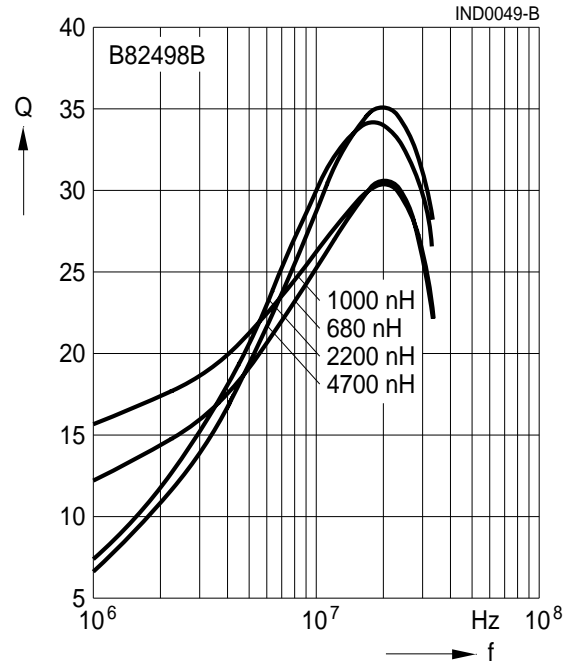

Inductance L versus DC load current I_{DC}

measured with RF LCR meter
Agilent 4275A, typical values at 20 °C

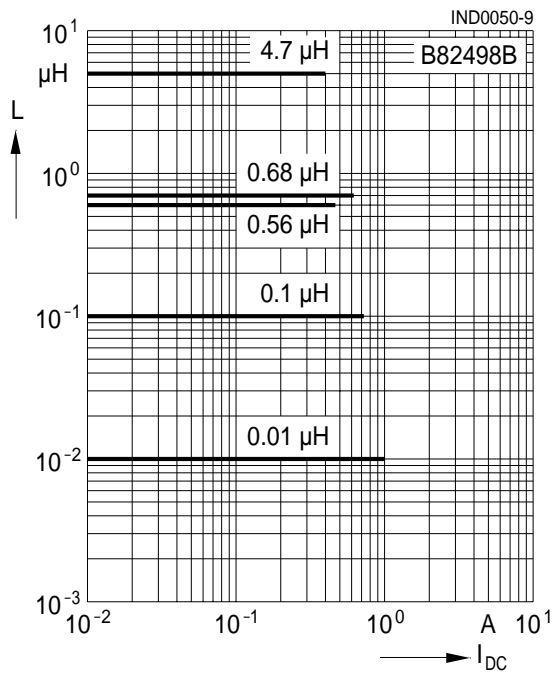

Current derating I_{op}/I_R versus ambient temperature T_A

(rated temperature T_R = 85 °C)

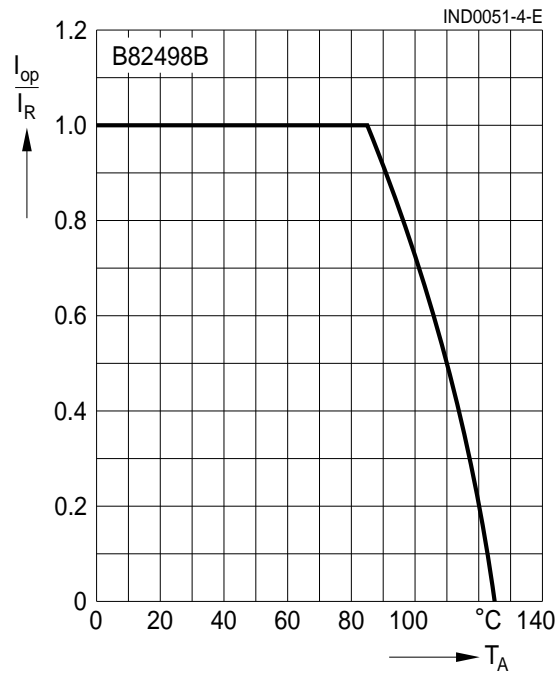

Cautions and warnings

- Please note the recommendations in our Inductors data book (latest edition) and in the data sheets.
 - Particular attention should be paid to the derating curves given there.
 - The soldering conditions should also be observed. Temperatures quoted in relation to wave soldering refer to the pin, not the housing.
- If the components are to be washed varnished it is necessary to check whether the washing varnish agent that is used has a negative effect on the wire insulation, any plastics that are used, or on glued joints. In particular, it is possible for washing varnish agent residues to have a negative effect in the long-term on wire insulation.
- The following points must be observed if the components are potted in customer applications:
 - Many potting materials shrink as they harden. They therefore exert a pressure on the plastic housing or core. This pressure can have a deleterious effect on electrical properties, and in extreme cases can damage the core or plastic housing mechanically.
 - It is necessary to check whether the potting material used attacks or destroys the wire insulation, plastics or glue.
 - The effect of the potting material can change the high-frequency behaviour of the components.
- Ferrites are sensitive to direct impact. This can cause the core material to flake, or lead to breakage of the core.
- Even for customer-specific products, conclusive validation of the component in the circuit can only be carried out by the customer.

Important notes

The following applies to all products named in this publication:

1. Some parts of this publication contain **statements about the suitability of our products for certain areas of application**. These statements are based on our knowledge of typical requirements that are often placed on our products in the areas of application concerned. We nevertheless expressly point out **that such statements cannot be regarded as binding statements about the suitability of our products for a particular customer application**.

As a rule, EPCOS is either unfamiliar with individual customer applications or less familiar with them than the customers themselves. For these reasons, it is always ultimately incumbent on the customer to check and decide whether an EPCOS product with the properties described in the product specification is suitable for use in a particular customer application.

2. We also point out that **in individual cases, a malfunction of electronic components or failure before the end of their usual service life cannot be completely ruled out in the current state of the art, even if they are operated as specified**. In customer applications requiring a very high level of operational safety and especially in customer applications in which the malfunction or failure of an electronic component could endanger human life or health (e.g. in accident prevention or life-saving systems), it must therefore be ensured by means of suitable design of the customer application or other action taken by the customer (e.g. installation of protective circuitry or redundancy) that no injury or damage is sustained by third parties in the event of malfunction or failure of an electronic component.

3. **The warnings, cautions and product-specific notes must be observed.**

4. In order to satisfy certain technical requirements, **some of the products described in this publication may contain substances subject to restrictions in certain jurisdictions (e.g. because they are classed as hazardous)**. Useful information on this will be found in our Material Data Sheets on the Internet (www.epcos.com/material). Should you have any more detailed questions, please contact our sales offices.

5. We constantly strive to improve our products. Consequently, **the products described in this publication may change from time to time**. The same is true of the corresponding product specifications. Please check therefore to what extent product descriptions and specifications contained in this publication are still applicable before or when you place an order.

We also **reserve the right to discontinue production and delivery of products**. Consequently, we cannot guarantee that all products named in this publication will always be available.

The aforementioned does not apply in the case of individual agreements deviating from the foregoing for customer-specific products.

6. Unless otherwise agreed in individual contracts, **all orders are subject to the current version of the “General Terms of Delivery for Products and Services in the Electrical Industry” published by the German Electrical and Electronics Industry Association (ZVEI)**.

7. The trade names EPCOS, BAOKE, Alu-X, CeraDiode, CSMP, CSSP, CTVS, DSSP, MiniBlue, MKK, MLSC, MotorCap, PCC, PhaseCap, PhaseCube, PhaseMod, SIFERRIT, SIFI, SIKOREL, SilverCap, SIMDAD, SIMID, SineFormer, SIOV, SIP5D, SIP5K, ThermoFuse, WindCap are **trademarks registered or pending** in Europe and in other countries. Further information will be found on the Internet at www.epcos.com/trademarks.