

## Features

- High FSK Sensitivity: -106 dBm at 20 kBaud/-109.5 dBm at 2.4 kBaud (433.92 MHz)
- High ASK Sensitivity: -112.5 dBm at 10 kBaud/-116.5 dBm at 2.4 kBaud (433.92 MHz)
- Low Supply Current: 10.5 mA in RX and TX Mode (3 V/TX with 5 dBm)
- Data Rate 1 to 20 kBaud Manchester FSK, 1 to 10 kBaud Manchester ASK
- ASK/FSK Receiver Uses a Low-IF Architecture with High Selectivity, Blocking and Low Intermodulation (Typical Blocking 55 dB at  $\pm 750$  kHz/61 dB at  $\pm 1.5$  MHz and 70 dB at  $\pm 10$  MHz, System I1dBCP = -30 dBm/System IIP3 = -20 dBm)
- 226 kHz IF Frequency with 30 dB Image Rejection and 170 kHz Usable IF Bandwidth
- Transmitter Uses Closed Loop Fractional-N Synthesizer for FSK Modulation with a High PLL Bandwidth and an Excellent Isolation between PLL and PA
- Tolerances of XTAL Compensated by Fractional-N Synthesizer with 800 Hz RF Resolution
- Integrated RX/TX-Switch, Single-ended RF Input and Output
- RSSI (Received Signal Strength Indicator)
- Communication to Microcontroller with SPI Interface Working at Maximum 500 kBit/s
- Configurable Self Polling and RX/TX Protocol Handling with FIFO-RAM Buffering of Received and Transmitted Data
- 5 Push Button Inputs and One Wake-up Input are Active in Power-down Mode
- Integrated XTAL Capacitors
- PA Efficiency: up to 38% (433 MHz/10 dBm/3 V)
- Low Inband Sensitivity Change of Typically  $\pm 1.8$  dB within  $\pm 58$  kHz Center Frequency Change in the Complete Temperature and Supply Voltage Range
- Supply Voltage Switch, Supply Voltage Regulator, Reset Generation, Clock/Interrupt Generation and Low Battery Indicator for Microcontroller
- Fully Integrated PLL with Low Phase Noise VCO and PLL Loop Filter
- Sophisticated Threshold Control and Quasi Peak Detector Circuit in the Data Slicer
- Power Management via Different Operation Modes
- 433.92 MHz, 868.3 MHz and 315 MHz without External VCO and PLL Components
- Inductive Supply with Voltage Regulator if Battery is Empty (AUX Mode)
- Efficient XTO Start-up Circuit ( $> -1.5$  k $\Omega$  Worst Case Start Impedance)
- Changing of Modulation Type ASK/FSK and Data Rate without Component Changes
- Minimal External Circuitry Requirements for Complete System Solution
- Adjustable Output Power: 0 to 10 dBm Adjusted and Stabilized with External Resistor
- ESD Protection at all Pins (2 kV HBM, 200 V MM)
- Supply Voltage Range: 2.4 V to 3.6 V or 4.4 V to 6.6 V
- Temperature Range: -40°C to +105°C
- Small 7  $\times$  7 mm QFN48 Package

## Applications

- Automotive Keyless Entry and Passive Entry Go Systems
- Access Control Systems
- Remote Control Systems
- Alarm and Telemetry Systems
- Energy Metering
- Home Automation

## Benefits

- No SAW Device Needed in Key Fob Designs to Meet Automotive Specifications
- Low System Cost Due to Very High System Integration Level
- Only One Crystal Needed in System
- Less Demanding Specification for the Microcontroller Due to Handling of Power-down Mode, Delivering of Clock, Reset, Low Battery Indication and Complete Handling of Receive/Transmit Protocol and Polling
- Single-ended Design with High Isolation of PLL/VCO from PA and the Power Supply Allows a Loop Antenna in the Key Fob to Surround the Whole Application



## UHF ASK/FSK Transceiver

ATA5811  
ATA5812

Preliminary

Rev. 4689B-RKE-04/04



## General Description

The ATA5811/ATA5812 is a highly integrated UHF ASK/FSK single-channel half-duplex transceiver with low power consumption supplied in a small QFN48 package. The receive part is built as a fully integrated low-IF receiver, whereas direct PLL modulation with the fractional-N synthesizer is used for FSK transmission and switching of the power amplifier for ASK transmission.

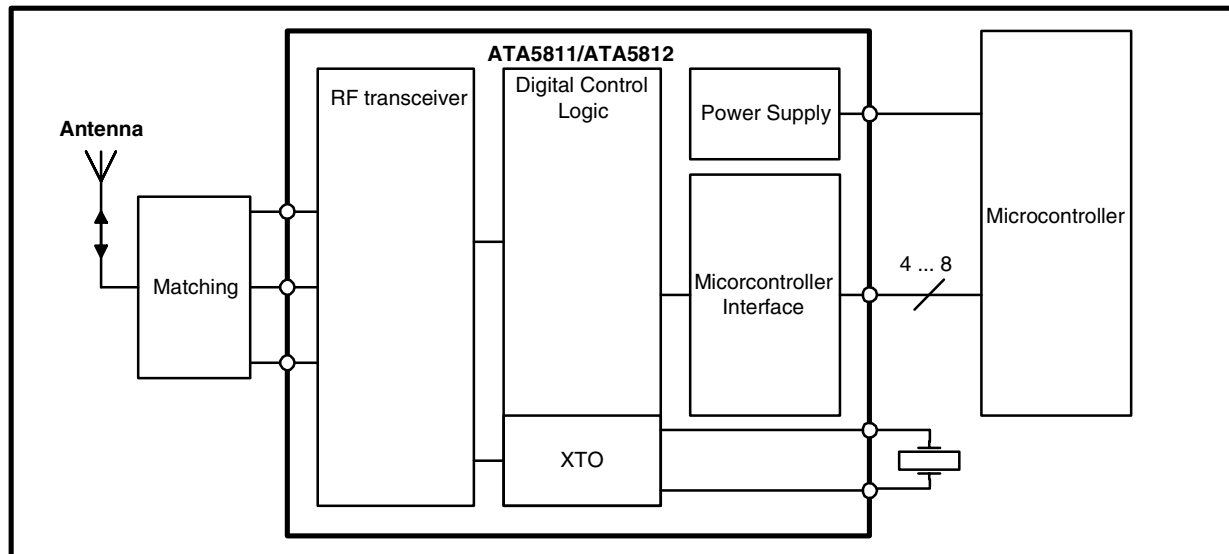
The device supports data rates of 1 kBaud to 20 kBaud (FSK) and 1 kBaud to 10 kBaud (ASK) in Manchester, Bi-phase and other codes in transparent mode. The ATA5811 can be used in the 433 MHz to 435 MHz and the 868 MHz to 870 MHz band, the ATA5812 in the 314 MHz to 316 MHz band. The very high system integration level results in few numbers of external components needed.

Due to its blocking and selectivity performance, together with the additional 15 dB to 20 dB loss and the narrow bandwidth of a typical key fob loop antenna, a bulky blocking SAW is not needed in the key fob or sensor application. Additionally, the building blocks needed for a typical RKE and access control system on both sides, the base and the mobile stations, are fully integrated.

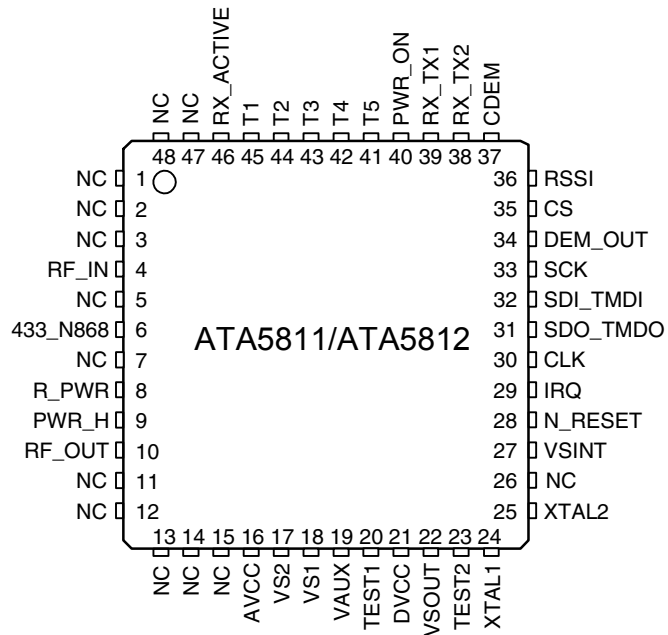
Its digital control logic with self polling and protocol generation enables a fast challenge response systems without using a high-performance microcontroller. Therefore, the ATA5811/ATA5812 contains a FIFO buffer RAM and can compose and receive the physical messages themselves. This provides more time for the microcontroller to carry out other functions such as calculating crypto algorithms, composing the logical messages and controlling other devices. Due to that, a standard 4-/8-bit microcontroller without special periphery and clocked with the CLK output of about 4.5 MHz is sufficient to control the communication link. This is especially valid for passive entry and access control systems, where within less than 100 ms several challenge response communications with arbitration of the communication partner have to be handled.

It is hence possible to design bi-directional RKE and access control systems with a fast challenge response crypto function with the same PCB board size and with the same current consumption as uni-directional RKE systems.

**Figure 1.** System Block Diagram



**Figure 2.** Pinning QFN48



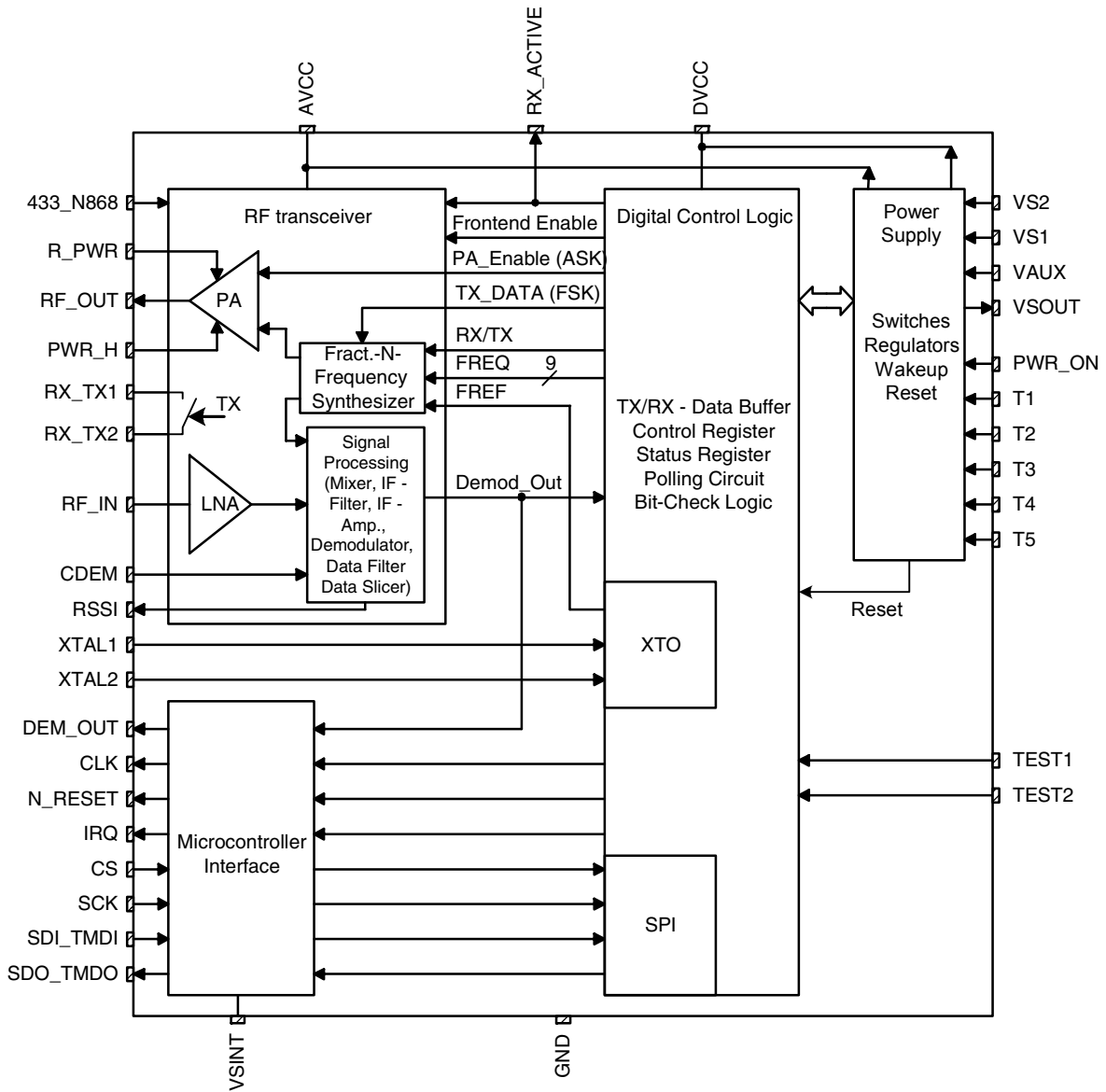
## Pin Description

Pin	Symbol	Function
1	NC	Not connected
2	NC	Not connected
3	NC	Not connected
4	RF_IN	RF input
5	NC	Not connected
6	433_N868	Selects RF input/output frequency range
7	NC	Not connected
8	R_PWR	Resistor to adjust output power
9	PWR_H	Pin to select output power
10	RF_OUT	RF output
11	NC	Not connected
12	NC	Not connected
13	NC	Not connected
14	NC	Not connected
15	NC	Not connected
16	AVCC	Blocking of the analog voltage supply
17	VS2	Power supply input for voltage range 4.4 V to 6.6 V
18	VS1	Power supply input for voltage range 2.4 V to 3.6 V

## Pin Description (Continued)

Pin	Symbol	Function
19	VAUX	Auxiliary supply voltage input
20	TEST1	Test input, at GND during operation
21	DVCC	Blocking of the digital voltage supply
22	VSOUT	Output voltage power supply for external devices
23	TEST2	Test input, at GND during operation
24	XTAL1	Reference crystal
25	XTAL2	Reference crystal
26	NC	Not connected
27	VSINT	Microcontroller Interface supply voltage
28	N_RESET	Output pin to reset a connected microcontroller
29	IRQ	Interrupt request
30	CLK	Output to clock a connected microcontroller
31	SDO_TMDO	Serial data out/transparent mode data out
32	SDI_TMDI	Serial data in/transparent mode data in
33	SCK	Serial clock
34	DEM_OUT	Demodulator open drain output signal
35	CS	Chip select for serial interface
36	RSSI	Output of the RSSI amplifier
37	CDEM	Capacitor to adjust the lower cut-off frequency data filter
38	RX_TX2	GND pin to decouple LNA in TX mode
39	RX_TX1	Switch pin to decouple LNA in TX mode
40	PWR_ON	Input to switch on the system (active high)
41	T1	Key input 1 (can also be used to switch on the system (active low))
42	T2	Key input 2 (can also be used to switch on the system (active low))
43	T3	Key input 3 (can also be used to switch on the system (active low))
44	T4	Key input 4 (can also be used to switch on the system (active low))
45	T5	Key input 5 (can also be used to switch on the system (active low))
46	RX_ACTIVE	Indicates RX operation mode
47	NC	Not connected
48	NC	Not connected
	GND	Ground/backplane

Figure 3. Block Diagram





## Typical Car or Sensor Base-station Application

Figure 5. Typical RKE Car or Sensor Base-station Application, 433.92 MHz

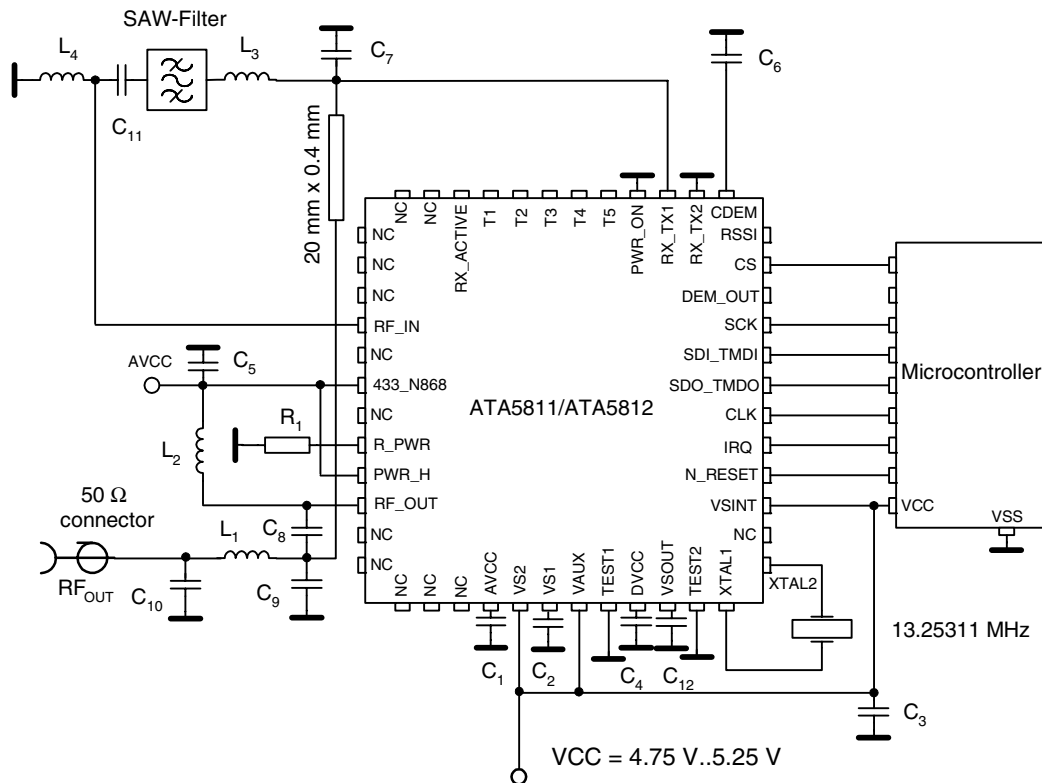


Figure 5 shows a typical 433.92 MHz  $V_{CC} = 4.75\text{ V}$  to  $5.25\text{ V}$  RKE car or sensor base-station application. The external components are 12 capacitors, 1 resistor, 4 inductors, a SAW filter and a crystal.  $C_1$  and  $C_3$  to  $C_4$  are 68 nF voltage supply blocking capacitors.  $C_2$  and  $C_{12}$  are 2.2  $\mu\text{F}$  supply blocking capacitors for the internal voltage regulators.  $C_5$  is a 10 nF supply blocking capacitor.  $C_6$  is a 15 nF fixed capacitor used for the internal quasi peak detector and for the highpass frequency of the data filter.  $C_7$  to  $C_{11}$  are RF matching capacitors in the range of 1 pF to 33 pF.  $L_2$  to  $L_4$  are matching inductors of about 5.6 nH to 56 nH. A load capacitor for the crystal of 9 pF is integrated.  $R_1$  is typically 22 k $\Omega$  and sets the output power at RF\_OUT to about 10 dBm. Since a quarter wave or PCB antenna, which has high efficiency and wide band operation, is typically used here, it is recommended to use a SAW filter to achieve high sensitivity in case of powerful out-of-band blockers.  $L_1$ ,  $C_{10}$  and  $C_9$  together form a lowpass filter, which is needed to filter out the harmonics in the transmitted signal to meet regulations. An internally regulated voltage at pin VSOUT can be used in case the microcontroller only supports 3.3 V operation, a blocking capacitor with a value of  $C_{12} = 2.2\ \mu\text{F}$  has to be connected to VSOUT in any case.

## Typical Key Fob Application, 2 Batteries

Figure 6. Typical RKE Key Fob Application, 433.92 MHz, 2 Batteries

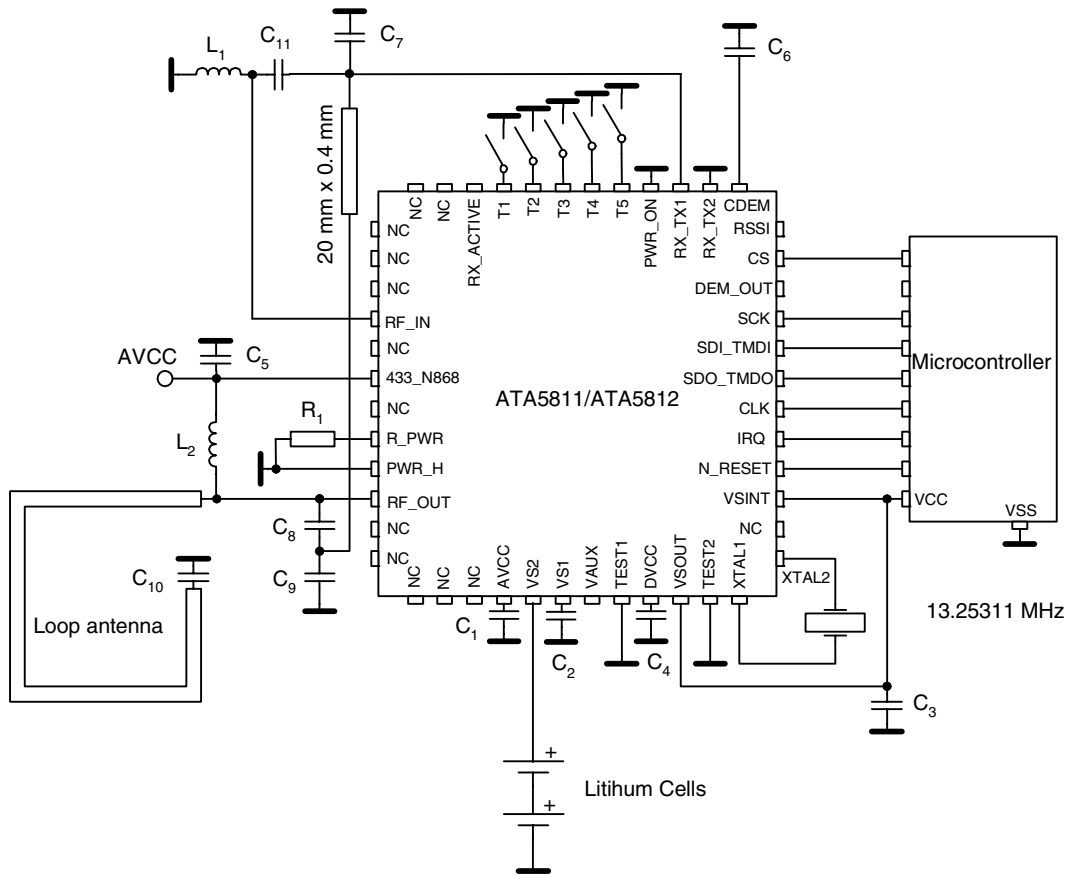


Figure 6 shows a typical 433.92 MHz 2-battery RKE key fob or sensor application. The external components are 11 capacitors, 1 resistor, 2 inductors and a crystal.  $C_1$  and  $C_4$  are 68 nF voltage supply blocking capacitors.  $C_2$  and  $C_3$  are 2.2  $\mu$ F supply blocking capacitors for the internal voltage regulators.  $C_5$  is a 10 nF supply blocking capacitor.  $C_6$  is a 15 nF fixed capacitor used for the internal quasi peak detector and for the highpass frequency of the data filter.  $C_7$  to  $C_{11}$  are RF matching capacitors in the range of 1 pF to 33 pF.  $L_1$  is a matching inductor of about 5.6 nH to 56 nH.  $L_2$  is a feed inductor of about 120 nH. A load capacitor for the crystal of 9 pF is integrated.  $R_1$  is typically 22 k $\Omega$  and sets the output power to about 5.5 dBm.



## RF Transceiver

According to Figure 3 on page 5, the RF transceiver consists of an LNA (Low-Noise Amplifier), PA (Power Amplifier), RX/TX switch, fractional-N frequency synthesizer and the signal processing part with mixer, IF filter, IF amplifier, FSK/ASK demodulator, data filter and data slicer.

In receive mode the LNA pre-amplifies the received signal which is converted down to 226 kHz, filtered and amplified before it is fed into an FSK/ASK demodulator, data filter and data slicer. The RSSI (Received Signal Strength Indicator) signal and the raw digital output signal of the demodulator are available at the pins RSSI and DEM\_OUT. The demodulated data signal Demod\_Out is fed to the digital control logic where it is evaluated and buffered as described in section "Digital Control Logic".

In transmit mode the fractional-N frequency synthesizer generates the TX frequency which is fed to the PA. In ASK mode the PA is modulated by the signal PA\_Enable. In FSK mode the PA is enabled and the signal TX\_DATA (FSK) modulates the fractional-N frequency synthesizer. The frequency deviation is digitally controlled and internally fixed to about  $\pm 16$  kHz (see Table 12 on page 24 for exact values). The transmit data can also be buffered as described in section "Digital Control Logic". A lock detector within the synthesizer ensures that the transmission will only start if the synthesizer is locked.

The RX/TX switch can be used to combine the LNA input and the PA output to a single antenna with a minimum of losses.

Transparent modes without buffering of RX and TX data are also available to allow protocols and coding schemes other than the internal supported Manchester encoding.

## Low-IF Receiver

The receive path consists of a fully integrated low-IF receiver. It fulfills the sensitivity, blocking, selectivity, supply voltage and supply current specification needed to manufacture an automotive key fob without the use of SAW blocking filter (see Figure 4 on page 6). The receiver can be connected to the roof antenna in the car when using an additional blocking SAW front-end filter as shown in Figure 5 on page 7.

At 433.92 MHz the receiver has a typical system noise figure of 7.0 dB, a system 11dBCP of -30 dBm and a system IIP3 of -20 dBm. There is no AGC or switching of the LNA needed, thus, a better blocking performance is achieved. This receiver uses an IF (Intermediate Frequency) of 226 kHz, the typical image rejection is 30 dB and the typical 3 dB IF filter bandwidth is 185 kHz ( $f_{IF} = 226 \text{ kHz} \pm 92.5 \text{ kHz}$ ,  $f_{lo\_IF} = 133.5 \text{ kHz}$  and  $f_{hi\_IF} = 318.5 \text{ kHz}$ ). The demodulator needs a signal to Gaussian noise ratio of 8 dB for 20 kBaud Manchester with  $\pm 16$  kHz frequency deviation in FSK mode, thus, the resulting sensitivity at 433.92 MHz is typically -106 dBm at 20 kBaud Manchester.

Due to the low phase noise and spurious of the synthesizer in receive mode<sup>(1)</sup> together with the eighth order integrated IF filter the receiver has a better selectivity and blocking performance than more complex double superhet receivers but without external components and without numerous spurious receiving frequencies.

A low-IF architecture is also less sensitive to second-order intermodulation (IIP2) than direct conversion receivers where every pulse or AM-modulated signal (especially the signals from TDMA systems like GSM) demodulates to the receiving signal band at second-order non-linearities.

Note: 1. -120 dBC/Hz at  $\pm 1$  MHz and -75 dBC at  $\pm F_{REF}$  at 433.92 MHz

## Input Matching at RF\_IN

The measured input impedances as well as the values of a parallel equivalent circuit of these impedances can be seen in Table 1. The highest sensitivity is achieved with power matching of these impedances to the source impedance of 50 Ω

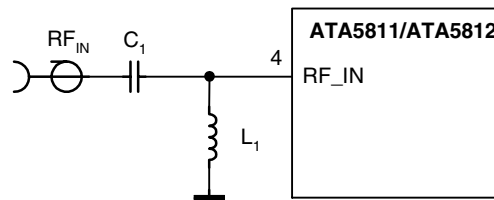
**Table 1.** Measured Input Impedances of the RF\_IN Pin

$f_{RF}/\text{MHz}$	$Z(\text{RF\_IN})$	$R_p//C_p$
315	$(44-j233)\Omega$	1278 Ω//2.1 pF
433.92	$(32-j169)\Omega$	925 Ω//2.1 pF
868.3	$(21-j78)\Omega$	311 Ω//2.2 pF

The matching of the LNA Input to 50 Ω was done with the circuit according to Figure 7 and with the values given in Table 2. The reflection coefficients were always  $\leq 10$  dB. Note that value changes of  $C_1$  and  $L_1$  may be necessary to for compensate individual board layouts. The measured typical FSK and ASK Manchester code sensitivities with a Bit Error Rate (BER) of  $10^{-3}$  are shown in Table 3 on page 11 and Table 4 on page 11. These measurements were done with inductors having a quality factor according to Table 2, resulting in estimated matching losses of 1.0 dB at 315 MHz, 1.2 dB at 433.92 MHz and 0.6 dB at 868.3 MHz. These losses can be estimated when calculating the parallel equivalent resistance of the inductor with  $R_{\text{loss}} = 2 \times \pi \times f \times L \times Q_L$  and the matching loss with  $10 \log(1+R_p/R_{\text{loss}})$ .

With an ideal inductor, for example, the sensitivity at 433.92 MHz/FSK/20 kBaud/  $\pm 16$  kHz/Manchester can be improved from -106 dBm to -107.2 dBm. The sensitivity depends on the control logic which examines the incoming data stream. The examination limits must be programmed in control registers 5 and 6. The measurements in Table 3 on page 11 and Table 4 on page 11 are based on the values of registers 5 and 6 according to Table 39 on page 57.

**Figure 7.** Input Matching to 50 Ω



**Table 2.** Input Matching to 50 Ω

$f_{RF}/\text{MHz}$	$C_1/\text{pF}$	$L_1/\text{nH}$	$Q_{L1}$
315	2.2	56	43
433.92	1.8	27	40
868.3	1.2	6.8	58

**Table 3.** Measured Sensitivity FSK,  $\pm 16$  kHz, Manchester, dBm, BER =  $10^{-3}$

RF Frequency	BR_Range_0 1.0 kBaud	BR_Range_0 2.4 kBaud	BR_Range_1 5.0 kBaud	BR_Range_2 10 kBaud	BR_Range_3 20 kBaud
315 MHz	-110.0 dBm	-110.5 dBm	-109.0 dBm	-108.0 dBm	-107.0 dBm
433.92 MHz	-109.0 dBm	-109.5 dBm	-108.0 dBm	-107.0 dBm	-106.0 dBm
868.3 MHz	-106.0 dBm	-106.5 dBm	-105.5 dBm	-104.0 dBm	-103.5 dBm

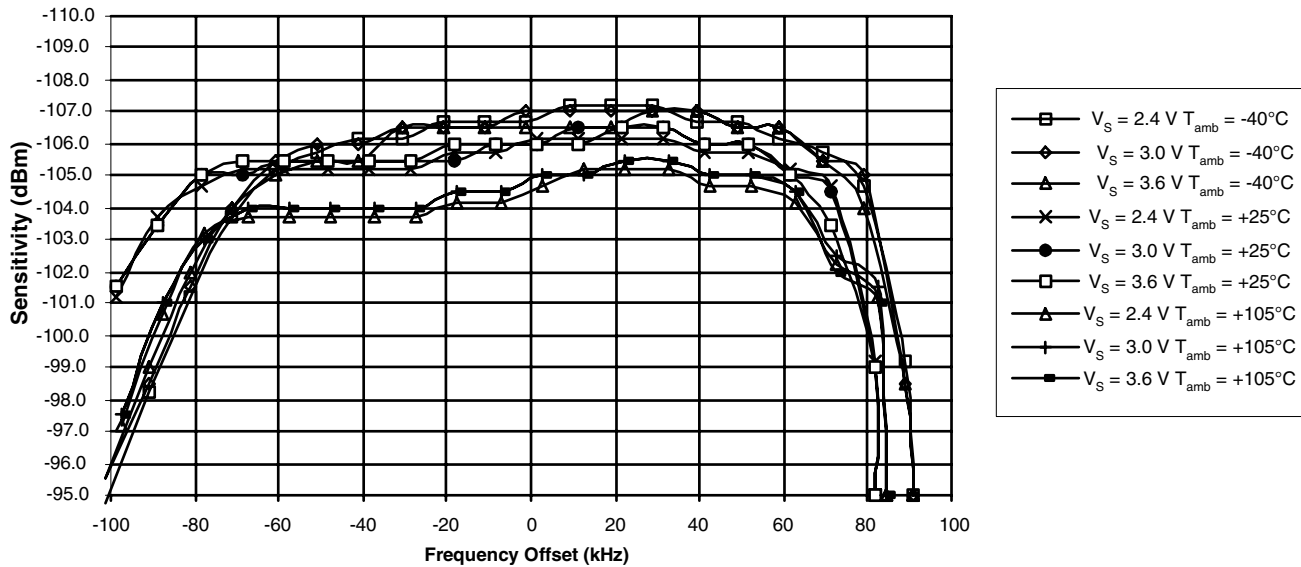
**Table 4.** Measured Sensitivity 100% ASK, Manchester, dBm, BER =  $10^{-3}$

RF Frequency	BR_Range_0 1.0 kBaud	BR_Range_0 2.4 kBaud	BR_Range_1 5.0 kBaud	BR_Range_2 10 kBaud
315 MHz	-117.0 dBm	-117.5 dBm	-115 dBm	-113.5 dBm
433.92 MHz	-116.0 dBm	-116.5 dBm	-114.0 dBm	-112.5 dBm
868.3 MHz	-112.5 dBm	-113.0 dBm	-111.5 dBm	-109.5 dBm

## Sensitivity versus Supply Voltage, Temperature and Frequency Offset

To calculate the behavior of a transmission system it is important to know the reduction of the sensitivity due to several influences. The most important are frequency offset due to crystal oscillator (XTO) and crystal frequency (XTAL) errors, temperature and supply voltage dependency of the noise figure and IF filter bandwidth of the receiver. Figure 8 shows the typical sensitivity at 433.92 MHz/FSK/20kBaud/ $\pm 16$  kHz/Manchester versus the frequency offset between transmitter and receiver with  $T_{amb} = -40^{\circ}\text{C}$ ,  $+25^{\circ}\text{C}$  and  $+105^{\circ}\text{C}$  and supply voltage  $V_{S1} = V_{S2} = 2.4$  V, 3.0 V and 3.6 V.

**Figure 8.** Measured Sensitivity 433.92 MHz/FSK/20 kBaud/ $\pm 16$  kHz/Manchester versus Frequency Offset, Temperature and Supply Voltage



As can be seen in Figure 8 on page 11 the supply voltage has almost no influence. The temperature has an influence of about +1.5/-0.7 dB and a frequency offset of  $\pm 65$  kHz also influences by about  $\pm 1$  dB. All these influences, combined with the sensitivity of a typical IC, are then within a range of -103.7 dBm and -107.3 dBm over temperature, supply voltage and frequency offset which is -105.5 dBm  $\pm 1.8$ dB. The integrated IF filter has an additional production tolerance of only  $\pm 7$  kHz, hence, a frequency offset between the receiver and the transmitter of  $\pm 58$  kHz can be accepted for XTAL and XTO tolerances.

Note: For the demodulator used in the ATA5811/ATA5812, the tolerable frequency offset does not change with the data frequency, hence, the value of  $\pm 58$  kHz is valid for up to 1 kBaud.

This small sensitivity spread over supply voltage, frequency offset and temperature is very unusual in such a receiver. It is achieved by an internal, very fast and automatic frequency correction in the FSK demodulator after the IF filter, which leads to a higher system margin. This frequency correction tracks the input frequency very quickly, if however, the input frequency makes a larger step (e.g., if the system changes between different communication partners), the receiver has to be restarted. This can be done by switching back to Idle mode and then again to RX mode. For that purpose, an automatic mode is also available. This automatic mode switches to Idle mode and back into RX mode every time a bit error occurs (see section "Digital Control Logic").

## Frequency Accuracy of the Crystals

The XTO is an amplitude regulated Pierce oscillator with integrated load capacitors. The initial tolerances (due to the frequency tolerance of the XTAL, the integrated capacitors on XTAL1, XTAL2 and the XTO's initial transconductance gm) can be compensated to a value within  $\pm 0.5$  ppm by measuring the CLK output frequency and programming the control registers 2 and 3 (see Table 20 on page 35 and Table 23 on page 36). The XTO then has a remaining influence of less than  $\pm 2$  ppm over temperature and supply voltage due to the bandgap controlled gm of the XTO.

The needed frequency stability of the used crystals over temperature and aging is hence  $\pm 58$  kHz/433.92 MHz -  $2 \times \pm 2.5$  ppm =  $\pm 128.66$  ppm for 433.92 MHz and  $\pm 58$  kHz/868.3 MHz -  $2 \times \pm 2.5$  ppm =  $\pm 61.8$  ppm for 868.3 MHz. Thus, the used crystals in receiver and transmitter each need to be better than  $\pm 64.33$  ppm for 433.92 MHz and  $\pm 30.9$  ppm for 868.3 MHz. In access control systems it may be advantageous to have a more tight tolerance at the base-station in order to relax the requirement for the key fob.

## RX Supply Current versus Temperature and Supply Voltage

Table 5 shows the typical supply current at 433.92 MHz of the transceiver in RX mode versus supply voltage and temperature with VS = VS1 = VS2. As you can see the supply current at 2.4 V and -40°C is less than the typical one which helps because this is also the operation point where a lithium cell has the worst performance. The typical supply current at 315 MHz or 868.3 MHz in RX mode is about the same as for 433.92 MHz.

**Table 5.** Measured 433.92 MHz Receive Supply Current in FSK Mode

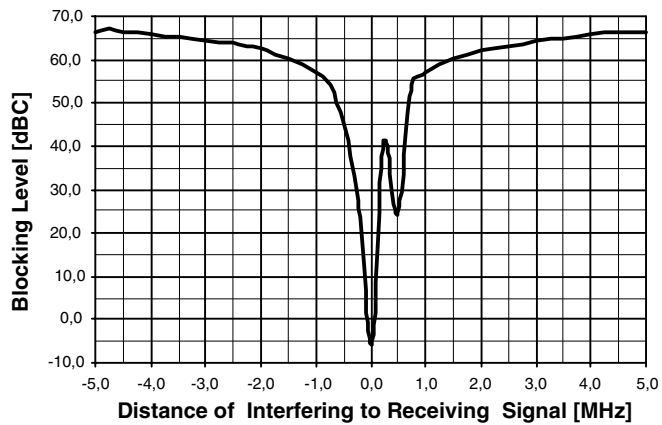
VS =	2.4 V	3.0 V	3.6 V
T <sub>amb</sub> = -40°C	8.4 mA	8.8 mA	9.2 mA
T <sub>amb</sub> = 25°C	9.9 mA	10.3 mA	10.8 mA
T <sub>amb</sub> = 105°C	11.4 mA	11.9 mA	12.4 mA

## Blocking, Selectivity

As can be seen in Figure 9 on page 13 and Figure 10 on page 13, the receiver can receive signals 3 dB higher than the sensitivity level in presence of very large blockers of -47 dBm/-34 dBm with small frequency offsets of  $\pm 1$ /  $\pm 10$  MHz.

Figure 9 shows narrow band blocking and Figure 10 wide band blocking characteristics. The measurements were done with a useful signal of 433.92 MHz/FSK/20 kBaud/±16 kHz/Manchester with a level of -106 dBm + 3 dB = -103 dBm which is 3 dB above the sensitivity level. The figures show how much a continuous wave signal can be larger than -103 dBm until the BER is higher than  $10^{-3}$ . The measurements were done at the 50 Ω input according to Figure 7 on page 10. At 1 MHz, for example, the blocker can be 56 dB higher than -103 dBm which is -103 dBm + 56 dB = -47 dBm. These values, together with the good intermodulation performance, avoid the need for a SAW filter in the key fob application.

**Figure 9.** Narrow Band 3 dB Blocking Characteristic at 433.92 MHz



**Figure 10.** Wide Band 3 dB Blocking Characteristic at 433.92 MHz

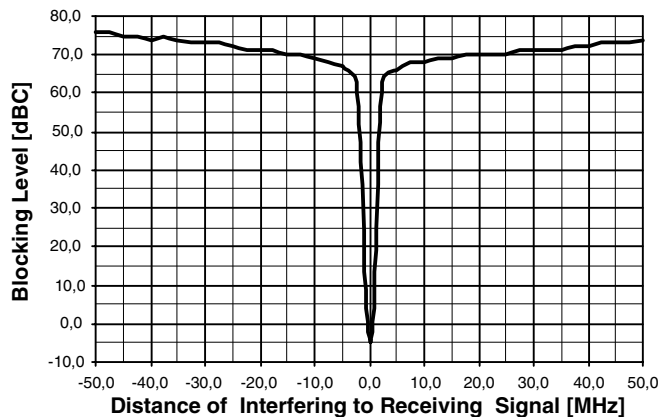


Figure 11 on page 14 shows the blocking measurement close to the received frequency to illustrate the selectivity and image rejection. This measurement was done 6 dB above the sensitivity level with a useful signal of 433.92 MHz/FSK/20kBaud/±16 kHz/Manchester with a level of -106 dBm + 6 dB = -100 dBm. The figure shows to which extent a continuous wave signal can surpass -100 dBm until the BER is higher than  $10^{-3}$ . For example, at 1 MHz the blocker can then be 59 dB higher than -100 dBm which is -100 dBm + 59 dB = -41 dBm.

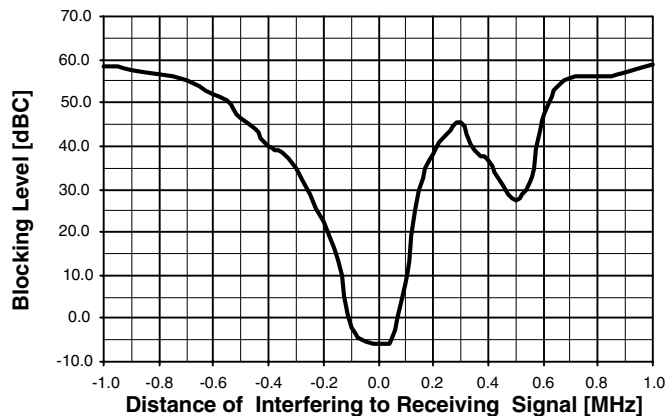
Table 6 shows the blocking performance measured relative to -100 dBm for some other frequencies. Note that sometimes the blocking is measured relative to the sensitivity level (dBS) instead of the carrier (dBC).

**Table 6.** Blocking 6 dB Above Sensitivity Level with BER < 10<sup>-3</sup>

Frequency Offset	Blocker Level	Blocking
+0.75 MHz	-45 dBm	55 dBC/61 dBS
-0.75 MHz	-45 dBm	55 dBC/61 dBS
+1.5 MHz	-38 dBm	62 dBC/68 dBS
-1.5 MHz	-38 dBm	62 dBC/68 dBS
+10 MHz	-30 dBm	70 dBC/76 dBS
-10 MHz	-30 dBm	70 dBC/76 dBS

The ATA5811/ATA5812 can also receive FSK and ASK modulated signals if they are much higher than the I1dBCP. It can typically receive useful signals at 10 dBm. This is often referred to as the nonlinear dynamic range which is the maximum to minimum receiving signal which is 116 dB for 20 kbaud Manchester. This value is useful if two transceivers have to communicate and are very close to each other.

**Figure 11.** Close In 6 dB Blocking Characteristic and Image Response at 433.92 MHz



This high blocking performance makes it even possible for some applications using quarter wave whip antennas to use a simple LC band-pass filter instead of a SAW filter in the receiver. When designing such an LC filter take into account that the 3 dB blocking at 433.92 MHz/2 = 216.96 MHz is 43 dBC and at 433.92 MHz/3 = 144.64 MHz is 48 dBC and at 2 × (433.92 MHz + 226 kHz) + -226 kHz = 868.066 MHz/868.518 MHz is 56 dBC. And especially that at 3 × (433.92 MHz + 226 kHz)+226 kHz = 1302.664 MHz the receiver has its second LO harmonic receiving frequency with only 12 dBC blocking.

### Inband Disturbers, Data Filter, Quasi Peak Detector, Data Slicer

If a disturbing signal falls into the received band or a blocker is not continuous wave the performance of a receiver strongly depends on the circuits after the IF filter. Hence the demodulator, data filter and data slicer are important in that case.

The data filter of the ATA5811/ATA5812 implies a quasi peak detector. This results in a good suppression of the above mentioned disturbers and exhibits a good carrier to Gaussian noise performance. The required useful signal to disturbing signal ratio to be received with a BER of  $10^{-3}$  is less than 12 dB in ASK mode and less than 3 dB (BR\_Range\_0 ... BR\_Range\_2)/6 dB (BR\_Range\_3) in FSK mode. Due to the many different waveforms possible these numbers are measured for signal as well as for disturbers with peak amplitude values. Note that these values are worst case values and are valid for any type of modulation and modulating frequency of the disturbing signal as well as the receiving signal. For many combinations, lower carrier to disturbing signal ratios are needed.

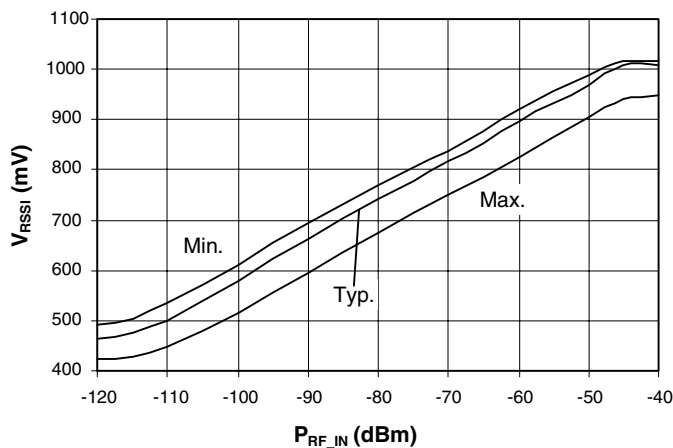
## DEM\_OUT Output

The internal raw output signal of the demodulator Demod\_Out is available at pin DEM\_OUT. DEM\_OUT is an open drain output and must be connected to a pull-up resistor if it is used (typically 100 k $\Omega$ ) otherwise no signal is present at that pin.

## RSSI Output

The output voltage of the pin RSSI is an analog voltage, proportional to the input power level. Using the RSSI output signal, the signal strength of different transmitters can be distinguished. The usable dynamic range of the RSSI amplifier is 70 dB, the input power range  $P(RF_{IN})$  is -115 dBm to -45 dBm and the gain is 8 mV/dB. Figure 12 shows the RSSI characteristic of a typical device at 433.92 MHz with  $VS1 = VS2 = 2, 4 V$  to 3, 6 V and  $T_{amb} = -40^{\circ}C$  to  $+105^{\circ}C$  with a matched input according to Table 2 on page 10 and Figure 7 on page 10. At 868.3 MHz about 2.7 dB more signal level and at 315 MHz about 1 dB less signal level is needed for the same RSSI results.

**Figure 12.** Typical RSSI Characteristic versus Temperature and Supply Voltage



## Frequency Synthesizer

The synthesizer is a fully integrated fractional-N design with internal loop filters for receive and transmit mode. The XTO frequency  $f_{XTO}$  is the reference frequency FREF for the synthesizer. The bits FR0 to FR8 in control registers 2 and 3 (see Table 20 on page 35 and Table 23 on page 36) are used to adjust the deviation of  $f_{XTO}$ . In transmit mode, at 433.92 MHz, the carrier has a phase noise of -111 dBC/Hz at 1 MHz and spurious at FREF of -66 dBC with a high PLL loop bandwidth allowing the direct modulation of the carrier with 20 kBaud Manchester data. Due to the closed loop modulation any spurious caused by this modulation are effectively filtered out as can be seen in Figure 15 on page 17. In RX mode the synthesizer has a phase noise of -120 dBC/Hz at 1 MHz and spurious of -75 dBC.

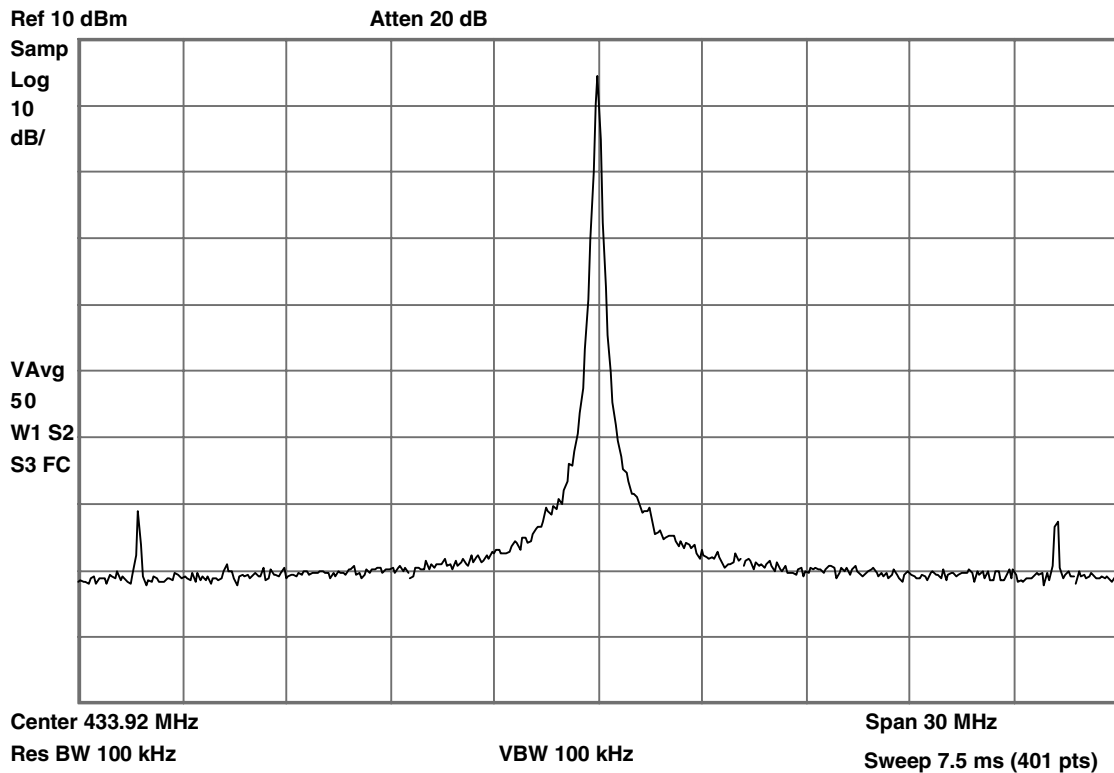
The initial tolerances of the crystal oscillator due to crystal tolerances, internal capacitor tolerances and the parasitics of the board have to be compensated at manufacturing setup with control registers 2 and 3 as can be seen in Table 12 on page 24. The other control words for the synthesizer needed for ASK, FSK and receive/transmit switching are calculated internally. The RF (Radio Frequency) resolution is equal to the XTO frequency divided by 16384 which is 777.1 Hz at 315.0 MHz, 808.9 Hz at 433.92 MHz and 818.59 Hz at 868.3 MHz.

### FSK/ASK Transmission

Due to the fast modulation capability of the synthesizer and the high resolution, the carrier can be internally FSK modulated which simplifies the application of the transceiver. The deviation of the transmitted signal is  $\pm 20$  digital frequency steps of the synthesizer which is equal to  $\pm 15.54$  kHz for 315 MHz,  $\pm 16.17$  kHz for 433.92 MHz and  $\pm 16.37$  kHz for 868.3 MHz.

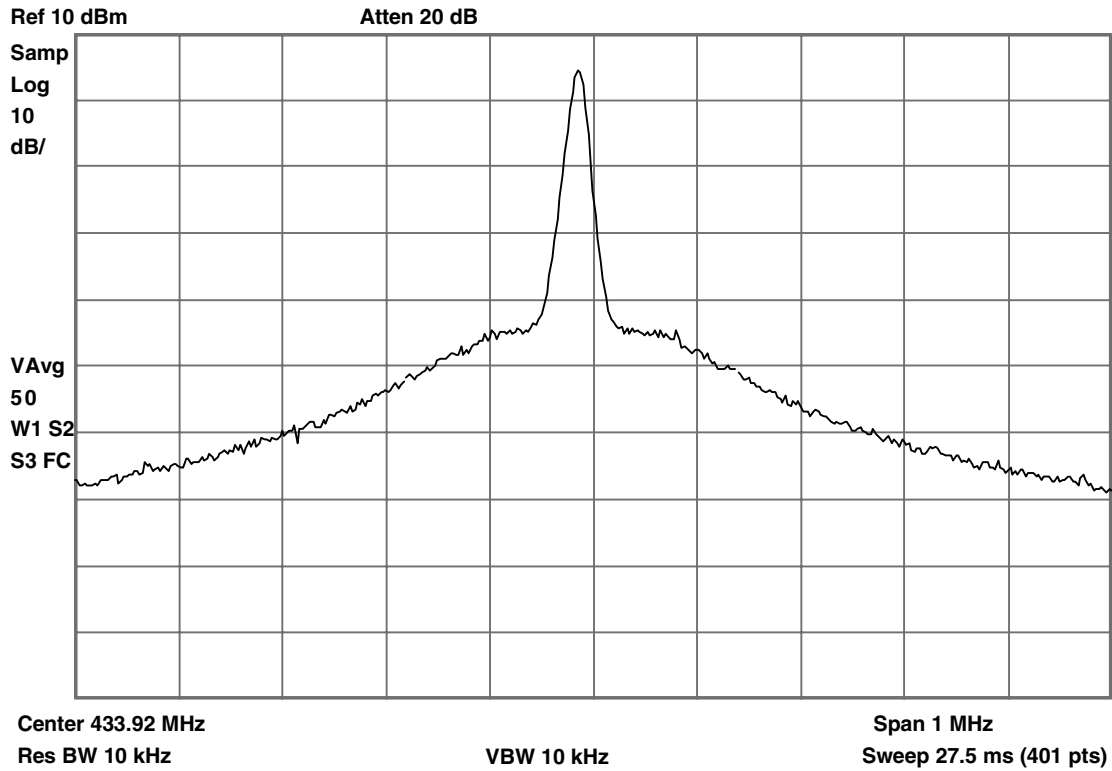
Due to closed loop modulation with PLL filtering the modulated spectrum is very clean, meeting ETSI and CEPT regulations when using a simple LC filter for the power amplifier harmonics as it is shown in Figure 5 on page 7. In ASK mode the frequency is internally connected to the center of the FSK transmission and the power amplifier is switched on and off to perform the modulation. Figure 13 to Figure 15 on page 17 show the spectrum of the FSK modulation with pseudo random data with 20 kBaud/ $\pm 16.17$  kHz/Manchester and 5 dBm output power.

**Figure 13.** FSK-modulated TX Spectrum (20 kBaud/ $\pm 16.17$  kHz/Manchester Code)

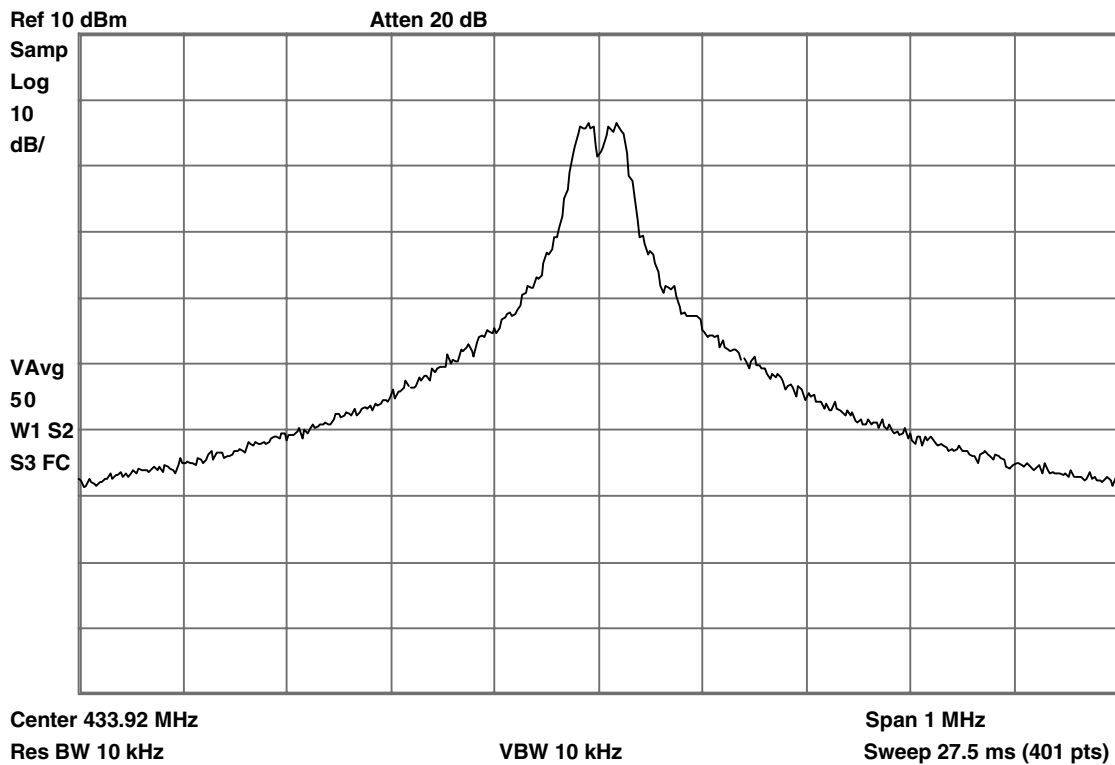




**Figure 14.** Unmodulated TX Spectrum  $f_{FSK\_L}$



**Figure 15.** FSK-modulated TX Spectrum (20 kBaud/±16.17 kHz/Manchester Code)



## Output Power Setting and PA Matching at RF\_OUT

The Power Amplifier (PA) is a single-ended open collector stage which delivers a current pulse which is nearly independent of supply voltage, temperature and tolerances due to bandgap stabilization. Resistor  $R_1$ , see Figure 16 on page 19, sets a reference current which controls the current in the PA. A higher resistor value results in a lower reference current, a lower output power and a lower current consumption of the PA. The usable range of  $R_1$  is 15 k $\Omega$  to 56 k $\Omega$ . Pin PWR\_H switches the output power range between about 0 dBm to 5 dBm (PWR\_H = GND) and 5 dBm to 10 dBm (PWR\_H = AVCC) by multiplying this reference current with a factor 1 (PWR\_H = GND) and 2.5 (PWR\_H = AVCC) which corresponds to about 5 dB more output power.

If the PA is switched off in TX mode, the current consumption without output stage with  $VS1 = VS2 = 3\text{ V}$ ,  $T_{\text{amb}} = 25^\circ\text{C}$  is typically 6.5 mA for 868.3 MHz and 6.95 mA for 315 MHz and 433.92 MHz.

The maximum output power is achieved with optimum load resistances  $R_{L\text{opt}}$  according to Table 7 on page 19 with compensation of the 1.0 pF output capacitance of the RF\_OUT pin by absorbing it into the matching network consisting of  $L_1$ ,  $C_1$ ,  $C_3$  as shown in Figure 16 on page 19. There must be also a low resistive DC path to AVCC to deliver the DC current of the power amplifier's last stage. The matching of the PA output was done with the circuit according to Figure 16 on page 19 with the values in Table 7 on page 19. Note that value changes of these elements may be necessary to compensate for individual board layouts.

Example:

According to Table 7 on page 19, with a frequency of 433.92 MHz and output power of 11 dBm the overall current consumption is typically 17.8 mA hence the PA needs 17.8 mA - 6.95 mA = 10.85 mA in this mode which corresponds to an overall power amplifier efficiency of the PA of  $(10^{(11\text{dBm}/10)} \times 1\text{ mW}) / (3\text{ V} \times 10.85\text{ mA}) \times 100\% = 38.6\%$  in this case.

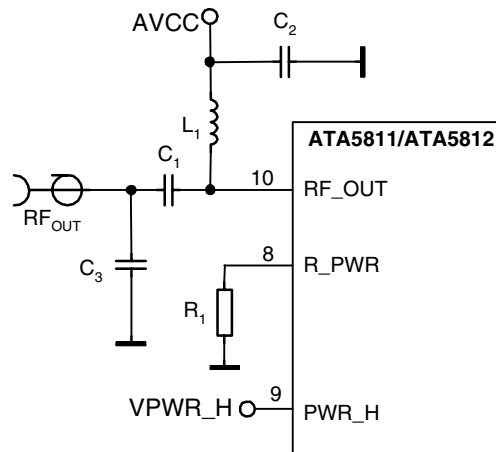
Using a higher resistor in this example of  $R_1 = 1.091 \times 22\text{ k}\Omega = 24\text{ k}\Omega$  results in 9.1% less current in the PA of 10.85 mA / 1.091 = 9.95 mA and  $10 \times \log(1.091) = 0.38\text{ dB}$  less output power if using a new load resistance of  $300\ \Omega \times 1.091 = 327\ \Omega$ . The resulting output power is then 11 dBm - 0.38 dB = 10.6 dBm and the overall current consumption is 6.95 mA + 9.95 mA = 16.9 mA.

The values of Table 7 on page 19 were measured with standard multi-layer chip inductors with quality factors Q according to Table 7 on page 19. Looking to the 433.92 MHz/11 dBm case with the quality factor of  $Q_{L1} = 43$  the loss in this inductor is estimated with the parallel equivalent resistance of the inductor  $R_{\text{loss}} = 2 \times \pi \times f \times L \times Q_{L1}$  and the matching loss with  $10 \log(1 + R_{L\text{opt}}/R_{\text{loss}})$  which is equal to 0.32 dB losses in this inductor. Taking this into account the PA efficiency is then 42% instead of 38.6%.

Be aware that the high power mode (PWR\_H = AVCC) can only be used with a supply voltage higher than 2.7 V, whereas the low power mode (PWR\_H = GND) can be used down to 2.4 V as can be seen in the section "Electrical Characteristics".

The supply blocking capacitor  $C_2$  (10 nF) has to be placed close to the matching network because of the RF current flowing through it.

**Figure 16.** Power Setting and Output Matching



**Table 7.** Measured Output Power and Current Consumption with VS1 = VS2 = 3 V, T<sub>amb</sub> = 25°C

Frequency (MHz)	TX Current (mA)	Output Power (dBm)	R1 (kΩ)	VPWR_H	R <sub>Lopt</sub> (Ω)	L1 (nH)	Q <sub>L1</sub>	C1 (pF)	C3 (pF)
315	8.5	0.4	56	GND	2500	82	28	1.5	0
315	10.5	5.7	27	GND	920	68	32	2.2	0
315	16.7	10.5	27	AVCC	350	56	35	3.9	0
433.92	8.6	0.1	56	GND	2300	56	40	0.75	0
433.92	11.2	6.2	22	GND	890	47	38	1.5	0
433.92	17.8	11	22	AVCC	300	33	43	2.7	0
868.3	9.3	-0.3	33	GND	1170	12	58	1.0	3.3
868.3	11.5	5.4	15	GND	471	15	54	1.0	0
868.3	16.3	9.5	22	AVCC	245	10	57	1.5	0

## Output Power and TX Supply Current versus Supply Voltage and Temperature

Table 8 on page 20 shows the measurement of the output power for a typical device with VS1 = VS2 = VS in the 433.92 MHz and 6.2 dBm case versus temperature and supply voltage measured according to Figure 16 on page 19 with components according to Table 7. As opposed to the receiver sensitivity the supply voltage has here the major impact on output power variations because of the large signal behavior of a power amplifier. Thus, a two battery system with voltage regulator or a 5 V system shows much less variation than a 2.4 V to 3.6 V one battery system because the supply voltage is then well within 3.0 V and 3.6 V.

The reason is that the amplitude at the output RF\_OUT with optimum load resistance is AVCC - 0.4 V and the power is proportional to (AVCC - 0.4 V)<sup>2</sup> if the load impedance is not changed. This means that the theoretical output power reduction if reducing the supply voltage from 3.0 V to 2.4 V is 10 log ((3 V - 0.4 V)<sup>2</sup> / (2.4 V - 0.4 V)<sup>2</sup>) = 2.2 dB. Table 8 on page 20 shows that principle behavior in the measurement. This is not the same case for higher voltages since here increasing the supply voltage from 3 V to 3.6 V should theoretical increase the power by 1.8 dB but only 0.8 dB in the measurement shows that the amplitude does not increase with the supply voltage because the load impedance is optimized for 3 V and the output amplitude stays more constant.

**Table 8.** Measured Output Power and Supply Current at 433.92 MHz, PWR\_H = GND

VS =	2.4 V	3.0 V	3.6 V
T <sub>amb</sub> = -40°C	10.19 mA 3.8 dBm	10.19 mA 5.5 dBm	10.78 mA 6.2 dBm
T <sub>amb</sub> = +25°C	10.62 mA 4.6 dBm	11.19 mA 6.2 dBm	11.79 mA 7.1 dBm
T <sub>amb</sub> = +105°C	11.4 mA 3.8 dBm	12.02 mA 5.4 dBm	12.73 mA 6.3 dBm

Table 9 shows the relative changes of the output power of a typical device compared to 3.0 V/25°C. As can be seen a temperature change to -40° as well as to +105° reduces the power by less than 1 dB due to the bandgap regulated output current. Measurements of all the cases in Table 7 on page 19 over temperature and supply voltage have shown about the same relative behavior as shown in Table 9

**Table 9.** Measurements of Typical Output Power Relative to 3 V/25°

VS =	2.4 V	3.0 V	3.6 V
T <sub>amb</sub> = -40°C	-2.4 dB	-0.7 dB	0 dB
T <sub>amb</sub> = +25°C	-1.6 dB	0 dB	+0.9 dB
T <sub>amb</sub> = +105°C	-2.4 dB	-0.8 dB	+0.1 dB

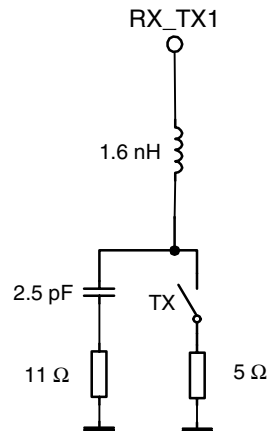
## RX/TX Switch

The RX/TX switch decouples the LNA from the PA in TX mode, and directs the received power to the LNA in RX mode. To do this, it has a low impedance to GND in TX mode and a high impedance to GND in RX mode. To design a proper RX/TX decoupling a linear simulation tool for radio frequency design together with the measured device impedances of Table 1 on page 10, Table 7 on page 19, Table 10 and Table 11 on page 22 should be used, but the exact element values have to be found on board. Figure 17 on page 21 shows an approximate equivalent circuit of the switch. The principal switching operation is described here according to the application of Figure 4 on page 6. The application of Figure 5 on page 7 works similarly.

**Table 10.** Impedance of the RX/TX Switch RX\_TX2 Shorted to GND

Frequency	Z(RX_TX1) TX Mode	Z(RX_TX1) RX Mode
315 MHz	(4.8 + j3.2) Ω	(11.3 - j214) Ω
433.92 MHz	(4.5 + j4.3) Ω	(10.3 - j153) Ω
868.3 MHz	(5 + j9) Ω	(8.9 - j73) Ω

Figure 17. Equivalent Circuit of the Switch



### Matching Network in TX Mode

In TX mode the 20 mm long and 0.4 mm wide transmission line which is much shorter than  $\lambda/4$  is approximately switched in parallel to the capacitor  $C_9$  to GND. The antenna connection between  $C_8$  and  $C_9$  has an impedance of about 50  $\Omega$  locking from the transmission line into the loop antenna with pin RF\_OUT,  $L_2$ ,  $C_{10}$ ,  $C_8$  and  $C_9$  connected (using a  $C_9$  without the added 7.6 pF as discussed later). The transmission line can be approximated with a 16 nH inductor in series with a 1.5  $\Omega$  resistor, the closed switch can be approximated according to Table 10 on page 20 with the series connection of 1.6 nH and 5  $\Omega$  in this mode. To have a parallel resonant high impedance circuit with little RF power going into it looking from the loop antenna into the transmission line a capacitor of about 7.6 pF to GND is needed at the beginning of the transmission line (this capacitor is later absorbed into  $C_9$  which is then higher as needed for 50  $\Omega$  transformation). To keep the 50  $\Omega$  impedance in RX mode at the end of this transmission line  $C_7$  has to be also about 7.6 pF. This reduces the TX power by about 0.5 dB at 433.92 MHz compared to the case where the LNA path is completely disconnected.

### Matching Network in RX Mode

In RX mode the RF\_OUT pin has a high impedance of about 7 k $\Omega$  in parallel with 1.0 pF at 433.92 MHz as can be seen in Table 11 on page 22. This together with the losses of the inductor  $L_2$  with 120 nH and  $Q_{L2} = 25$  gives about 3.7 k $\Omega$  loss impedance at RF\_OUT. Since the optimum load impedance in TX mode for the power amplifier at RF\_OUT is 890  $\Omega$  the loss associated with the inductor  $L_2$  and the RF\_OUT pin can be estimated to be  $10 \times \log(1 + 890/3700) = 0.95$  dB compared to the optimum matched loop antenna without  $L_2$  and RF\_OUT. The switch represents, in this mode at 433.92 MHz, about an inductor of 1.6 nH in series with the parallel connection of 2.5 pF and 2.0 k $\Omega$ . Since the impedance level at pin RX\_TX1 in RX mode is about 50  $\Omega$  this only negligibly dampens the received signal by about 0.1 dB. When matching the LNA to the loop antenna the transmission line and the 7.6 pF part of  $C_9$  has to be taken into account when choosing the values of  $C_{11}$  and  $L_1$  so that the impedance seen from the loop antenna into the transmission line with the 7.6 pF capacitor connected is 50  $\Omega$ . Since the loop antenna in RX mode is loaded by the LNA input impedance the loaded Q of the loop antenna is lowered by about a factor of 2 in RX mode hence the antenna bandwidth is higher than in TX mode.

**Table 11.** Impedance RF\_OUT Pin in RX Mode

Frequency	Z(RF_OUT)RX	R <sub>p</sub> /C <sub>p</sub>
315 MHz	36 Ω -j 502 Ω	7 kΩ // 1.0 pF
433.92 MHz	19 Ω -j 366 Ω	7 kΩ // 1.0 pF
868.3 MHz	2.8 Ω -j 141Ω	7 kΩ // 1.3 pF

Note that if matching to 50 Ω, like in Figure 5 on page 7, a high Q wire wound inductor with a Q > 70 should be used for L<sub>2</sub> to minimize its contribution to RX losses which will otherwise be dominant. The RX and TX losses will be in the range of 1.0 dB there.

## XTO

The XTO is an amplitude regulated Pierce oscillator type with integrated load capacitances (2 × 18 pF with a tolerance of ±17%) hence C<sub>Lmin</sub> = 7.4 pF and C<sub>Lmax</sub> = 10.6 pF. The XTO oscillation frequency f<sub>XTO</sub> is the reference frequency FREF for the fractional-N synthesizer. When designing the system in terms of receiving and transmitting frequency offset the accuracy of the crystal and XTO have to be considered.

The synthesizer can adjust the local oscillator frequency for more than ±150 ppm at 433.92 MHz/315 MHz and up to ±118 ppm at 868.3 MHz of initial frequency error in f<sub>XTO</sub>. This is done at nominal supply voltage and temperature with the control registers 2 and 3 (see Table 20 on page 35 and Table 23 on page 36). The remaining local oscillator tolerance at nominal supply voltage and temperature is then < ±0.5 ppm. A XTO frequency error of ±150 ppm/±118 ppm can hence be tolerated due to the crystal tolerance at 25°C and the tolerances of C<sub>L1</sub> and C<sub>L2</sub>. The XTO's gm has very low influence of less than ±2 ppm on the frequency at nominal supply voltage and temperature.

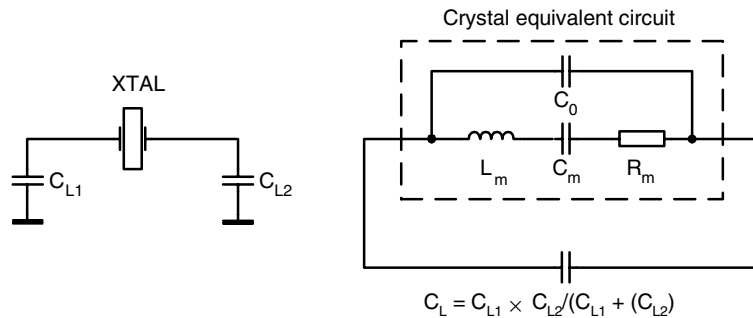
Over temperature and supply voltage, the XTO's additional pulling is only ±2 ppm if C<sub>m</sub> ≤ 7 fF. The XTAL versus temperature and its aging is then the main source of frequency error in the local oscillator.

The XTO frequency depends on XTAL properties and the load capacitances C<sub>L1,2</sub> at pin XTAL1 and XTAL2. The pulling of f<sub>XTO</sub> from the nominal f<sub>XTAL</sub> is calculated using the following formula:

$$P = \frac{C_m}{2} \times \frac{C_{LN} - C_L}{(C_0 + C_{LN}) \times (C_0 + C_L)} \times 10^6 \text{ ppm.}$$

C<sub>m</sub> is the crystal's motional, C<sub>0</sub> the shunt and C<sub>LN</sub> the nominal load capacitance of the XTAL found in its data sheet. C<sub>L</sub> is the total actual load capacitance of the crystal in the circuit and consists of C<sub>L1</sub> and C<sub>L2</sub> in series connection.

**Figure 18.** XTAL with Load Capacitance



With  $C_m \leq 14$  fF,  $C_0 \geq 1.5$  pF,  $C_{LN} = 9$  pF and  $C_L = 7.6$  pF to  $10.6$  pF the pulling amounts to  $P \leq \pm 100$  ppm and with  $C_m \leq 7$  fF,  $C_0 \geq 1.5$  pF,  $C_{LN} = 9$  pF and  $C_L = 7.4$  pF to  $10.6$  pF the pulling is  $P \leq \pm 50$  ppm.

Since typical crystals have less than  $\pm 50$  ppm tolerance at  $25^\circ$  the compensation is not critical.

$C_0$  of the XTAL has to be lower than  $C_{Lmin}/2 = 3.8$  pF for a Pierce oscillator type in order to not enter the steep region of pulling versus load capacitance where there is a risk of an unstable oscillation.

To ensure proper start-up behavior the small signal gain and thus the negative resistance provided by this XTO at start is very large, for example oscillation starts up even in worst case with a crystal series resistance of  $1.5$  k $\Omega$  at  $C_0 \leq 2.2$  pF with this XTO. The negative resistance is approximately given by

$$\text{Re}\{Z_{xtocore}\} = \text{Re}\left\{\frac{Z_1 \times Z_3 + Z_2 \times Z_3 + Z_1 \times Z_2 \times Z_3 \times g_m}{Z_1 + Z_2 + Z_3 + Z_1 \times Z_2 \times g_m}\right\}$$

with  $Z_1, Z_2$  as complex impedances at pin XTAL1 and XTAL2 hence

$$Z_1 = -j/(2 \times \pi \times f_{XTO} \times C_{L1}) + 5 \Omega \text{ and } Z_2 = -j/(2 \times \pi \times f_{XTO} \times C_{L2}) + 5 \Omega$$

$Z_3$  consists of crystals  $C_0$  in parallel with an internal  $110$  k $\Omega$  resistor hence

$$Z_3 = -j/(2 \times \pi \times f_{XTO} \times C_0) / 110 \text{ k}\Omega, g_m \text{ is the internal transconductance between XTAL1 and XTAL2 with typically } 19 \text{ ms at } 25^\circ\text{C}.$$

With  $f_{XTO} = 13.5$  MHz,  $g_m = 19$  ms,  $C_L = 9$  pF,  $C_0 = 2.2$  pF this results in a negative resistance of about  $2$  k $\Omega$ . The worst case for technological, supply voltage and temperature variations is then for  $C_0 \leq 2.2$  pF always higher than  $1.5$  k $\Omega$ .

Due to the large gain at start the XTO is able to meet a very low start-up time. The oscillation start-up time can be estimated with the time constant  $\tau$ .

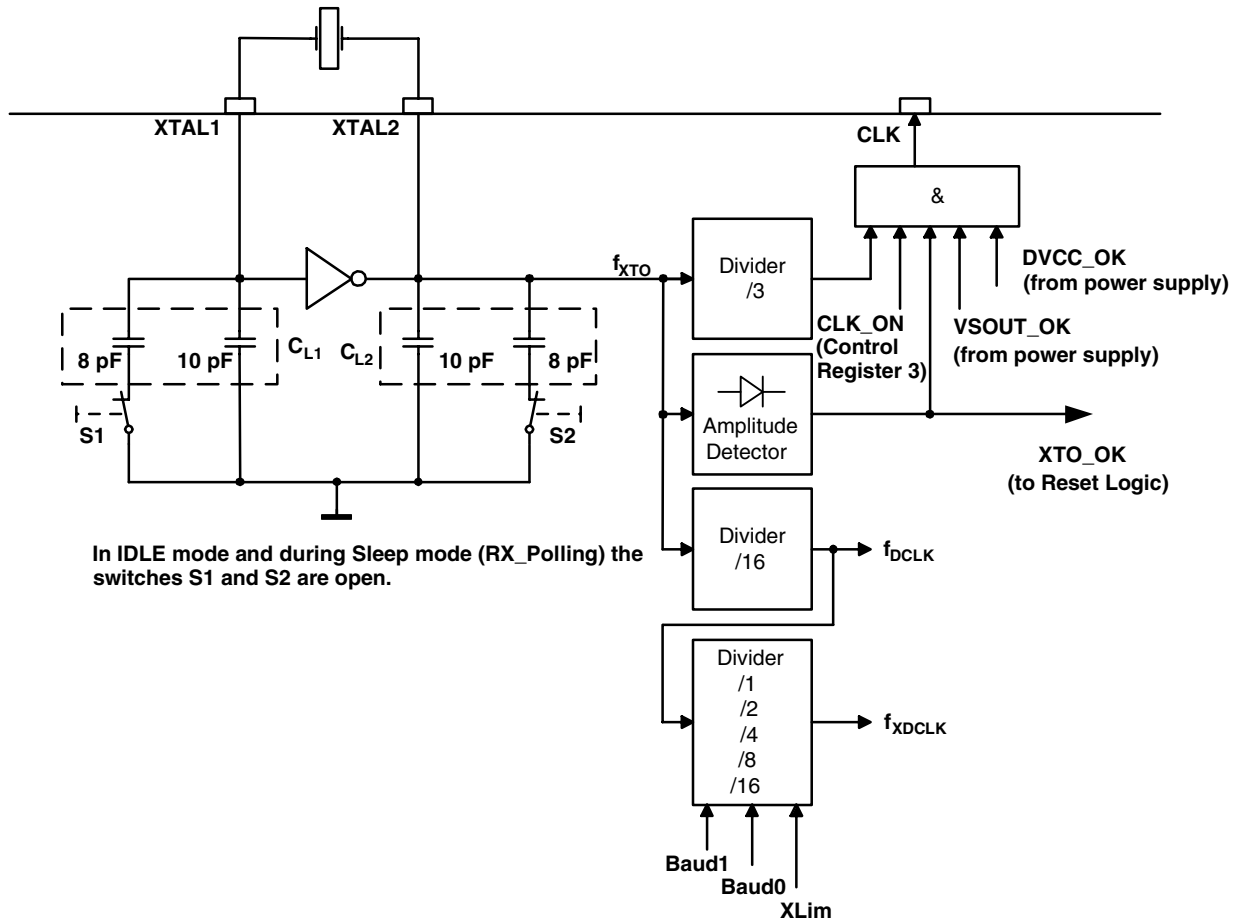
$$\tau = \frac{2}{4 \times \pi^2 \times f_m^2 \times C_m \times (\text{Re}(Z_{xtocore}) + R_m)}$$

After  $10 \tau$  to  $20 \tau$  an amplitude detector detects the oscillation amplitude and sets XTO\_OK to High if the amplitude is large enough, this sets N\_RESET to High and activates the CLK output if CLK\_ON in control register 3 is High (see Table 20 on page 35). Note that the necessary conditions of the VSOUT and DVCC voltage also have to be fulfilled (see Figure 19 on page 24 and Figure 21 on page 26).

To save current in Idle and sleep mode, the load capacitors partially are switched off in this modes with S1 and S2 seen in Figure 19 on page 24.

It is recommended to use a crystal with  $C_m = 4.0$  fF to  $7.0$  fF,  $C_{LN} = 9$  pF,  $R_m < 120 \Omega$  and  $C_0 = 1.5$  pF to  $2.2$  pF.

**Figure 19.** XTO Block Diagram



To find the right values used in the control registers 2 and 3 (see Table 20 on page 35 and Table 23 on page 36) the relationship between  $f_{XTO}$  and the  $f_{RF}$  is shown in Table 12. To determine the right content the frequency at pin CLK as well as the output frequency at RF\_OUT in ASK mode can be measured, then the  $FREQ$  value can be calculated according to Table 12 so that  $f_{RF}$  is exactly the desired radio frequency

**Table 12.** Calculation of  $f_{RF}$

Frequency (MHz)	Pin 6 433_N868	CREG1 Bit(4) FS	$f_{XTO}$ (MHz)	$f_{RF} = f_{TX\_ASK} = f_{RX}$	$f_{TX\_FSK\_L}$	$f_{TX\_FSK\_H}$
433.92	AVCC	0	13.25311	$f_{XTO} \times \left( 32, 5 + \frac{FREQ + 20,5}{16384} \right)$	$f_{RF} - 16.17$ kHz	$f_{RF} + 16.17$ kHz
868.3	GND	0	13.41191	$f_{XTO} \times \left( 64, 5 + \frac{FREQ + 20,5}{16384} \right)$	$f_{RF} - 16.37$ kHz	$f_{RF} + 16.37$ kHz
315.0	AVCC	1	12.73193	$f_{XTO} \times \left( 24, 5 + \frac{FREQ + 20,5}{16384} \right)$	$f_{RF} - 15.54$ kHz	$f_{RF} + 15.54$ kHz



The variable  $FREQ$  depends on  $FREQ2$  and  $FREQ3$ , which are defined by the bits  $FR0$  to  $FR8$  in control register 2 and 3 and is calculated as follows:

$$FREQ = 3584 + FREQ2 + FREQ3$$

Only the range of  $FREQ = 3803$  to  $4053$  of this register should be used because otherwise harmonics of  $f_{XTO}$  and  $f_{CLK}$  can cause interference with the received signals ( $FREQ_{min} = 3803$ ,  $FREQ_{max} = 4053$ ). The resulting tuning range is  $\pm 118$  ppm at  $868.3$  MHz and more than  $\pm 150$  ppm at  $433.92$  MHz or  $315$  MHz.

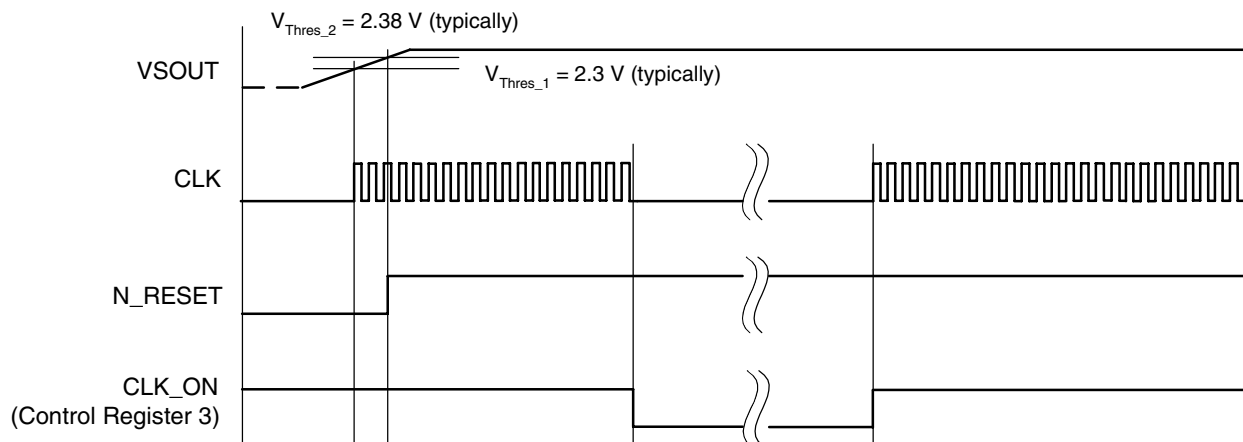
## Pin CLK

Pin CLK is an output to clock a connected microcontroller. The clock frequency  $f_{CLK}$  is calculated as follows:

$$f_{CLK} = \frac{f_{XTO}}{3}$$

Because the enabling of pin CLK is asynchronous the first clock cycle may be incomplete. The signal at CLK output has a nominal 50% duty cycle.

**Figure 20.** Clock Timing



## Basic Clock Cycle of the Digital Circuitry

The complete timing of the digital circuitry is derived from one clock. According to Figure 19 on page 24, this clock cycle  $T_{DCLK}$  is derived from the crystal oscillator (XTO) in combination with a divider.

$$f_{DCLK} = \frac{f_{XTO}}{16}$$

$T_{DCLK}$  controls the following application relevant parameters:

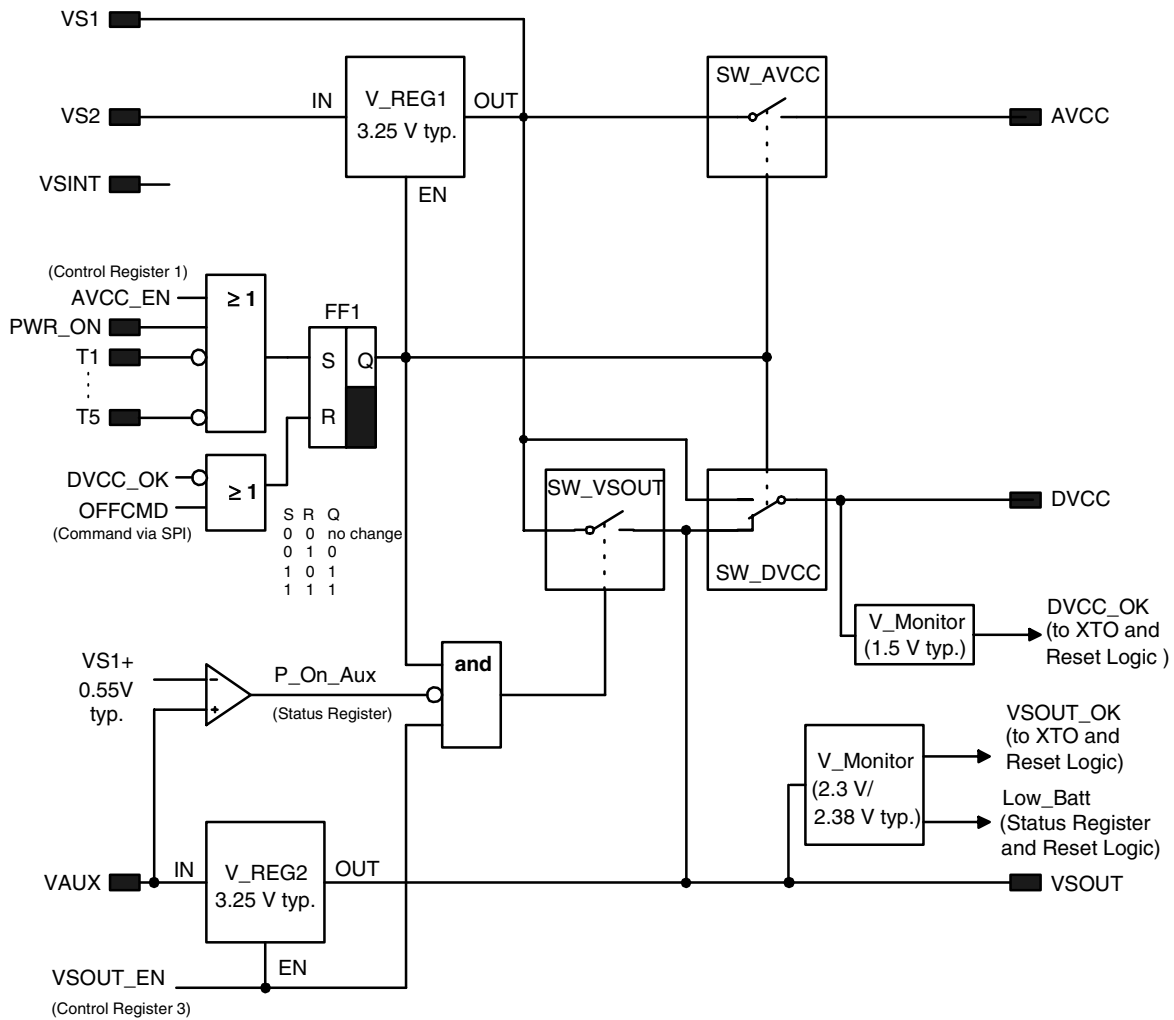
- Timing of the polling circuit including Bit-check
- TX baud rate

The clock cycle of the Bit-check and the TX baud rate depends on the selected baud-rate range ( $BR\_Range$ ) which is defined in control register 6 (see Table 33 on page 38) and  $XLim$  which is defined in control register 4 (see Table 26 on page 36). This clock cycle  $T_{XDCLK}$  is defined by the following formulas for further reference:

$$\begin{aligned}
 BR\_Range \Rightarrow \quad & BR\_Range\ 0: T_{XDCLK} = 8 \times T_{DCLK} \times XLim \\
 & BR\_Range\ 1: T_{XDCLK} = 4 \times T_{DCLK} \times XLim \\
 & BR\_Range\ 2: T_{XDCLK} = 2 \times T_{DCLK} \times XLim \\
 & BR\_Range\ 3: T_{XDCLK} = 1 \times T_{DCLK} \times XLim
 \end{aligned}$$

# Power Supply

Figure 21. Power Supply



The supply voltage range of the ATA5811/ATA5812 is 2.4 V to 3.6 V or 4.4 V to 6.6 V.

Pin VS1 is the supply voltage input for the range 2.4 V to 3.6 V and is used in battery applications using a single lithium 3 V cell. Pin VS2 is the voltage input for the range 4.4 V to 6.6 V (2 Battery Application and Car Applications) in this case the voltage regulator V\_REG1 regulates VS1 to typically 3.25 V. If the voltage regulator is active a blocking capacitor of 2.2  $\mu$ F has to be connected to VS1.

Pin VAUX is an input for an additional auxiliary voltage supply and can be connected e.g., to an inductive supply (see Figure 26 on page 32). This input can only be used together with a rectifier or as in the application of Figure 5 on page 7 and must otherwise be left open.

Pin VSINT is the voltage input for the Microcontroller\_Interface and must be connected to the power supply of the microcontroller. The voltage range of  $V_{VSINT}$  is 2.4 V to 5.25 V (see Figure 25 on page 31 and Figure 26 on page 32).

AVCC is the internal operation voltage of the RF transceiver and is fed via the switch SW\_AVCC by VS1. AVCC must be blocked with a 68 nF capacitor (see Figure 4 on page 6, Figure 5 on page 7 and Figure 6 on page 8).

DVCC is the internal operation voltage of the digital control logic and is fed via the switch SW\_DVCC by VS1 or VSOUT. DVCC must be blocked on pin DVCC with 68 nF (see Figure 4 on page 6, Figure 5 on page 7 and Figure 6 on page 8).

Pin VSOUT is a power supply output voltage for external devices (e.g., microcontroller) and is fed via the switch SW\_VSOUT by VS1 or via V\_REG2 by the auxiliary voltage supply VAUX. The voltage regulator V\_REG2 regulates VSOUT to typically 3.25 V. If the voltage regulator is active a blocking capacitor of 2.2  $\mu$ F has to be connected to VSOUT. VSOUT can be switched off by the VSOUT\_EN bit in control register 3 and is then reactivated by conditions found in Figure 22 on page 28.

Pin N\_RESET is set to low if the voltage  $V_{VSOUT}$  at pin VSOUT drops below 2.3 V (typically) and can be used as a reset signal for a connected microcontroller (see Figure 23 on page 30 and Figure 24 on page 31).

Pin PWR\_ON is an input to switch on the transceiver (active high).

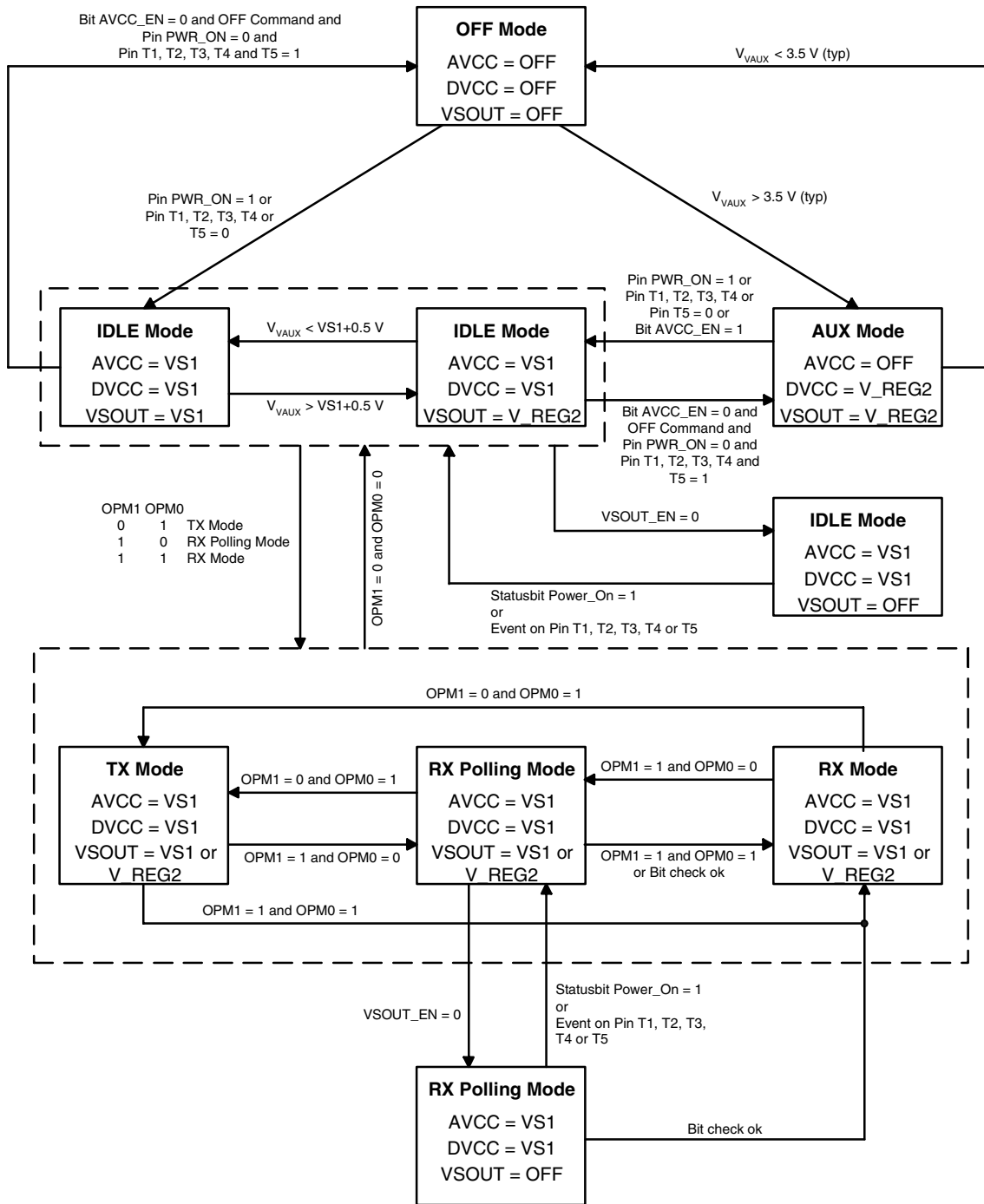
Pin T1 to T5 are inputs for push buttons and can also be used to switch on the transceiver (active low).

For current consumption reasons it is recommended to set T1 to T5 to GND or PWR\_ON to VCC only temporarily. Otherwise an additional current flows.

There are two voltage monitors generating the following signals (see Figure 21 on page 26):

- DVCC\_OK if DVCC > 1.5 V typically
- VSOUT\_OK if VSOUT >  $V_{Thres1}$  (2.3 V typically)
- Low\_Batt if VSOUT <  $V_{Thres2}$  (2.38 V typically)

**Figure 22. Flow Chart Operation Modes**



**OFF Mode**

After connecting the power supply (battery) to pin VS1 and/or VS2 and if the voltage on pin VAUX  $V_{VAUX} < 3.5\text{ V}$  (typically) the transceiver is in OFF mode. In OFF mode AVCC, DVCC and VSOUT are disabled, resulting in very low power consumption ( $I_{S\_OFF}$  is typically 10 nA). In OFF mode the transceiver is not programmable via the 4-wire serial interface.

## AUX Mode

The transceiver changes from OFF mode to AUX mode if the voltage at pin VAUX  $V_{VAUX} > 3.5$  V (typically). In AUX mode DVCC and VSOUT are connected to the auxiliary power supply input (VAUX) via the voltage regulator V\_REG2. In AUX mode the transceiver is programmable via the 4-wire serial interface, but no RX or TX operations are possible because AVCC = OFF.

The state transition OFF mode to AUX mode is indicated by an interrupt at pin IRQ and the status bit P\_On\_Aux = 1.

## Idle Mode

In Idle mode AVCC and DVCC are connected to the battery voltage (VS1).

From OFF mode the transceiver changes to Idle mode if pin PWR\_ON is set to 1 or pin T1, T2, T3, T4 or T5 is set to 0. This state transition is indicated by an interrupt at pin IRQ and the status bits Power\_On = 1 or ST1, ST2, ST3, ST4 or ST5 = 1.

From AUX mode the transceiver changes to Idle mode by setting AVCC\_EN = 1 in control register 1 via the 4-wire serial interface or if pin PWR\_ON is set to 1 or pin T1, T2, T3, T4 or T5 is set to 0.

VSOUT is either connected to VS1 or to the auxiliary power supply (V\_REG2).

If  $V_{VAUX} < VS1 + 0.5$  V, VSOUT is connected to VS1. If  $V_{VAUX} > VS1 + 0.5$  V, VSOUT is connected to V\_REG2 and the status bit P\_On\_Aux is set to 1.

In Idle mode the RF transceiver is disabled and the power consumption  $I_{S\_IDLE}$  is about 230  $\mu$ A (VSOUT OFF and CLK output OFF  $VS1 = VS2 = 3$  V). The exact value of this current is strongly dependent on the application and the exact operation mode, therefore check the section “Electrical Characteristics” for the appropriate application case.

Via the 4-wire serial interface a connected microcontroller can program the required parameter and enable the TX, RX polling or RX mode.

The transceiver can be set back to OFF mode by an OFF command via the 4-wire serial interface (the bit AVCC\_EN must be set to 0, the input level of pin PWR\_ON must be 0 and pin T1, T2, T3, T4 and T5 = 1 before writing the OFF command).

**Table 13.** Control Register 1

OPM1	OPM0	Function
0	0	Idle mode

## Reset Timing and Reset Logic

If the transceiver is switched on (OFF mode to Idle mode, OFF mode to AUX mode) DVCC and VSOUT are ramping up as illustrated in Figure 23 on page 30 (AVCC only ramps up if the transceiver is set to the Idle mode). The internal signal DVCC\_RESET resets the digital control logic and sets the control register to default values.

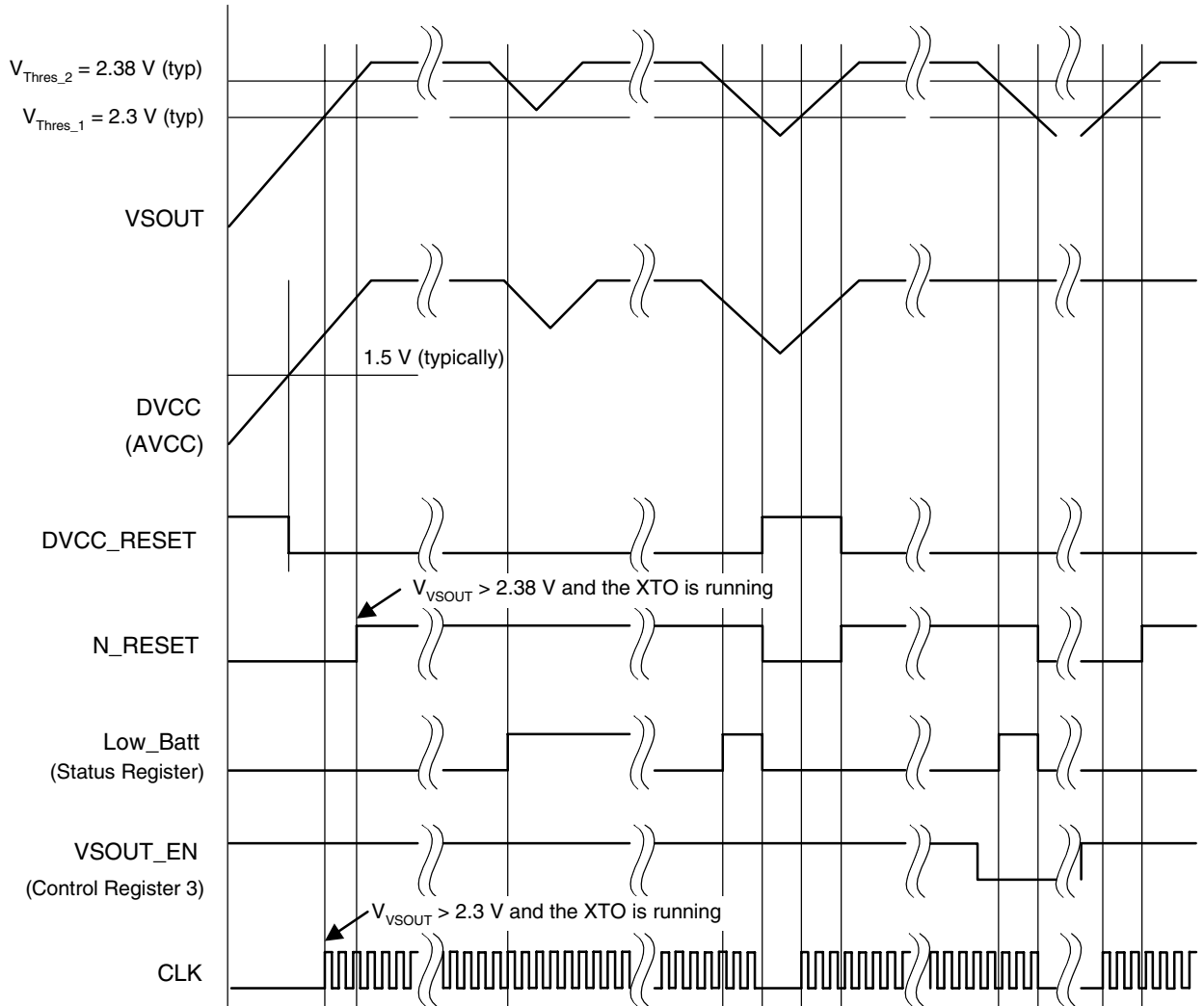
A voltage monitor generates a low level at pin N\_RESET until the voltage at pin VSOUT exceeds 2.38 V (typically) and the start-up time of the XTO has elapsed (amplitude detector, see Figure 19 on page 24). After the voltage at pin VSOUT exceeds 2.3 V (typically) and the start-up time of the XTO has elapsed the output clock at pin CLK is available. Because the enabling of pin CLK is asynchronous the first clock cycle may be incomplete.

The status bit Low\_Batt is set to 1 if the voltage at pin VSOUT  $V_{VSOUT}$  drops below  $V_{Thres\_2}$  (typically 2.38 V). Low\_Batt is set to 0 if  $V_{VSOUT}$  exceeds  $V_{Thres\_2}$  and the status register is read via the 4-wire serial interface or N\_RESET is set to low.

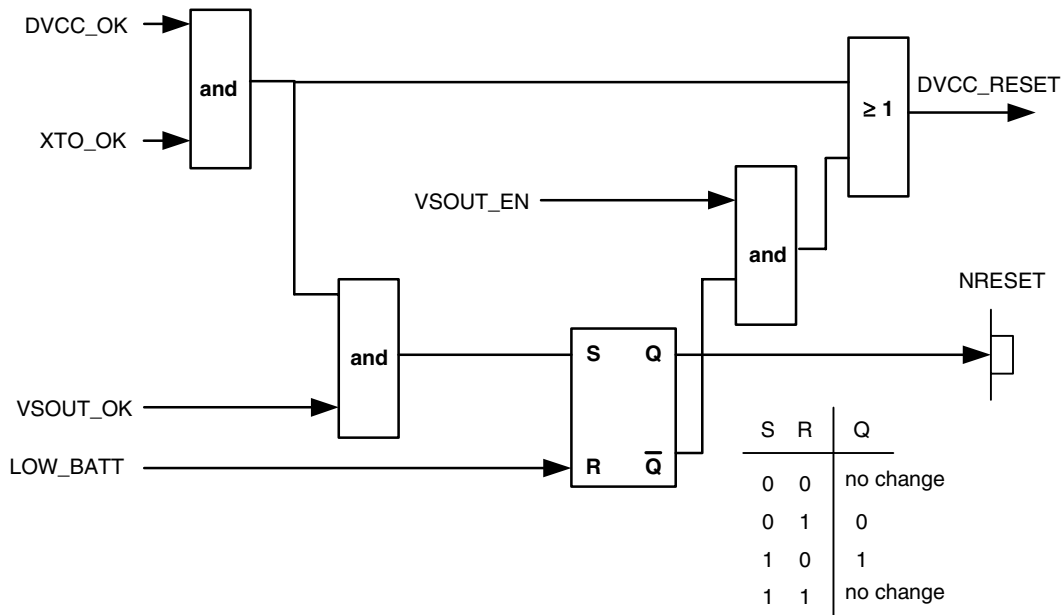
If  $V_{VSOUT}$  drops below  $V_{Thres\_1}$  (typically 2.3 V), N\_RESET is set to low. If bit VSOUT\_EN in control register 3 is 1, a DVCC\_RESET is also generated. If  $V_{VSOUT}$  was prior disabled by the connected microcontroller by setting bit VSOUT\_EN = 0, no DVCC\_RESET is generated.

Note: If  $VSOUT < V_{Thres\_1}$  (typically 2.3 V) the output of the pin CLK is low, the Microcontroller\_Interface is disabled and the transceiver is not programmable via the 4-wire serial interface.

**Figure 23. Reset Timing**



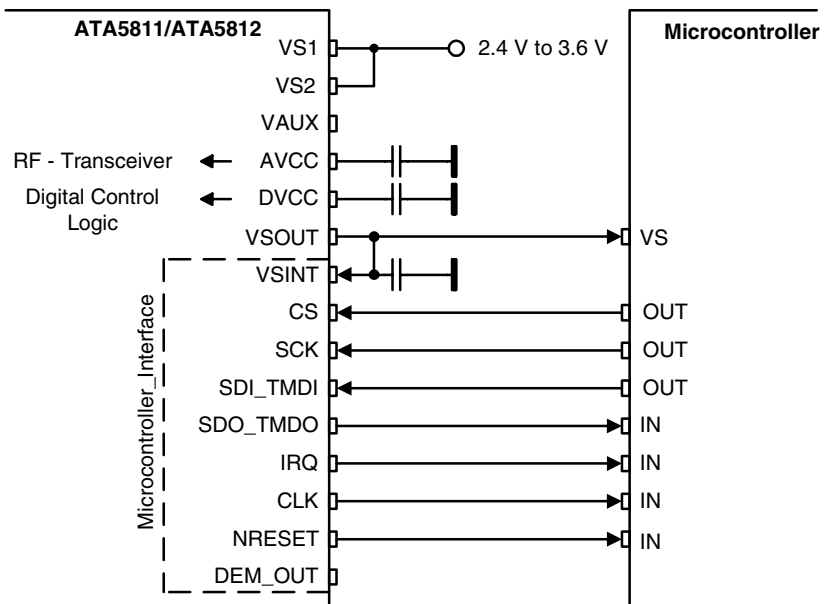
**Figure 24.** Reset Logic, SR Latch Generates the Hysteresis in the NRESET Signal



## 1-Battery Application

The supply voltage range is 2.4 V to 3.6 V and VAUX is not used.

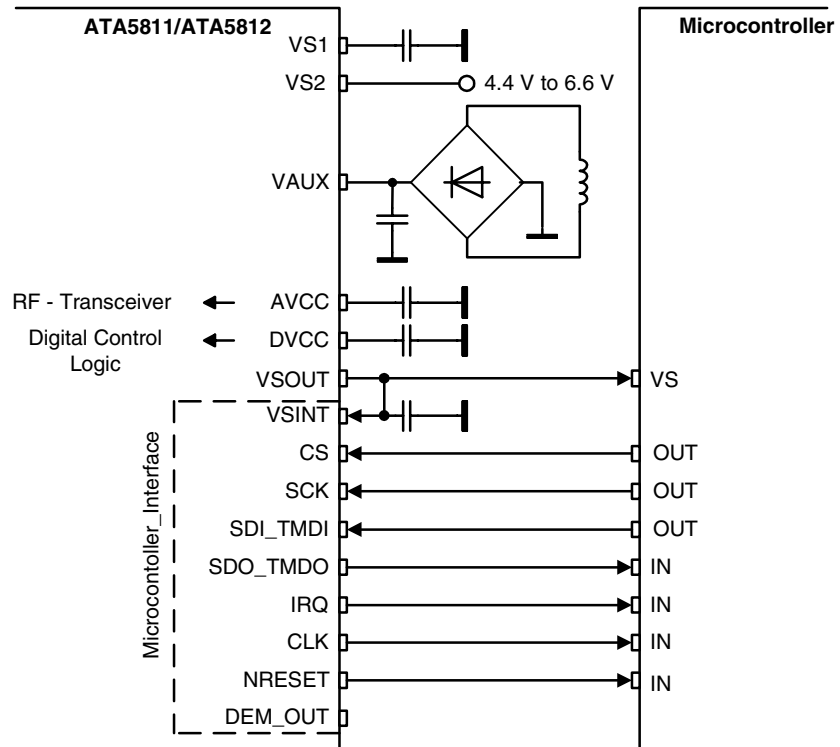
**Figure 25.** 1-Battery Application



## 2-Battery Application

The supply voltage range is 4.4 V to 6.6 V and VAUX is connected to an inductive supply.

**Figure 26.** 2-Battery Application with Inductive Emergency Supply



## Microcontroller Interface

The microcontroller interface is a level converter which converts all internal digital signals which are referred to the DVCC voltage, into the voltage used by the microcontroller. Therefore, the pin VSINT has to be connected to the supply voltage of the microcontroller.

This makes it possible to use the internal voltage regulator/switch at pin VSOUT as in Figure 4 on page 6 and Figure 6 on page 8 or to connect the microcontroller and the pin VSINT directly to the supply voltage of the microcontroller as in Figure 5 on page 7.

## Digital Control Logic

### Register Structure

The configuration of the transceiver is stored in RAM cells. The RAM contains a  $16 \times 8$ -bit TX/RX data buffer and a  $6 \times 8$ -bit control register and is write and readable via a 4-wire serial interface (CS, SCK, SDI\_TMDI, SDO\_TMDO).

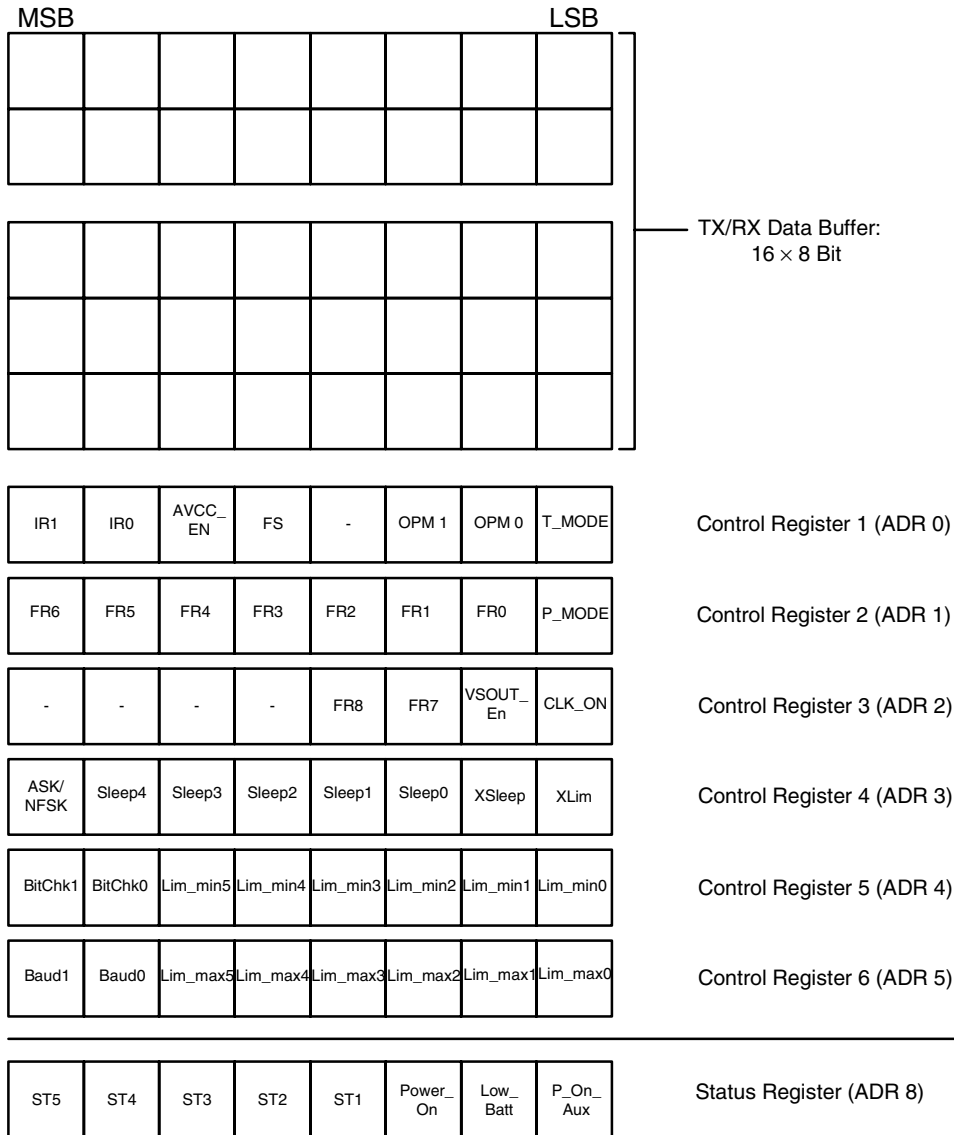
The  $1 \times 8$ -bit status register is not part of the RAM and is readable via the 4-wire serial interface.

The RAM and the status information is stored as long as the transceiver is in any active mode ( $DVCC = VS1$  or  $DVCC = V\_REG2$ ) and gets lost if the transceiver is in OFF mode ( $DVCC = OFF$ ).



After the transceiver is turned on via pin PWR\_ON = High, T1 = Low, T2 = Low, T3 = Low, T4 = Low or T5 = Low or the voltage at pin VAUX  $V_{VAUX} > 3.5$  V (typically) the control registers are in the default state.

**Figure 27.** Register Structure



## TX/RX Data Buffer

The TX/RX data buffer is used to handle the data transfer during RX and TX operations.

## Control Register

To use the transceiver in different applications it can be configured by a connected microcontroller via the 4-wire serial interface.

### Control Register 1 (ADR 0)

**Table 14.** Control Register 1 (Function of Bit 7 and Bit 6 in RX Mode)

IR1	IR0	Function (RX Mode)
0	0	Pin IRQ is set to 1 if 4 received bytes are in the TX/RX data buffer or a receiving error occurred
0	1	Pin IRQ is set to 1 if 8 received bytes are in the TX/RX data buffer or a receiving error occurred
1	0	Pin IRQ is set to 1 if 12 received bytes are in the TX/RX data buffer or a receiving error occurred (default)
1	1	Pin IRQ is set to 1 if a receiving error occurred

**Table 15.** Control Register 1 (Function of Bit 7 and Bit 6 in TX Mode)

IR1	IR0	Function (TX Mode)
0	0	Pin IRQ is set to 1 if 4 bytes still are in the TX/RX data buffer or the TX data buffer is empty
0	1	Pin IRQ is set to 1 if 8 bytes still are in the TX/RX data buffer or the TX data buffer is empty
1	0	Pin IRQ is set to 1 if 12 bytes still are in the TX/RX data buffer or the TX data buffer is empty (default)
1	1	Pin IRQ is set to 1 if the TX data buffer is empty

**Table 16.** Control Register 1 (Function of Bit 5)

AVCC_EN	Function
0	(default)
1	Enables AVCC, if the ATA5811/ATA5812 is in AUX mode

**Table 17.** Control Register 1 (Function of Bit 4)

FS	Function
0	433/868 MHz
1	315 MHz

**Table 18.** Control Register 1 (Function of Bit 2 and Bit 1)

OPM1	OPM0	Function
0	0	Idle mode (default)
0	1	TX mode
1	0	RX polling mode
1	1	RX mode

**Table 19.** Control Register 1 (Function of Bit 0)

T_MODE	Function
0	TX and RX function via TX/RX data buffer (default)
1	Transparent mode, TX/RX data buffer disabled, TX modulation data stream via pin SDI_TMDI, RX modulation data stream via pin SDO_TMDO

## Control Register 2 (ADR 1)

**Table 20.** Control Register 2 (Function of Bit 7, Bit 6, Bit 5, Bit 4, Bit 3, Bit 2 and Bit 1)

FR6	FR5	FR4	FR3	FR2	FR1	FR0	Function
0	0	0	0	0	0	0	FREQ2 = 0
0	0	0	0	0	0	1	FREQ2 = 1
.	.	.	.	.	.	.	
1	0	1	1	0	0	0	FREQ2 = 88 (default)
.	.	.	.	.	.	.	
1	1	1	1	1	1	1	FREQ2 = 127

Note: Tuning of  $f_{RF}$  LSB's (total 9 bits), frequency trimming, resolution of  $f_{RF}$  is  $f_{XTO}/16384$  which is approximately 800 Hz (see section "XTO", Table 12 on page 24)

**Table 21.** Control Register 2 (Function of Bit 0 in RX Mode)

P_MODE	Function (RX Mode)
0	Pin IRQ is set to 1 if the Bit-check is successful (default)
1	No effect on pin IRQ if the Bit-check is successful

**Table 22.** Control Register 2 (Function of Bit 0 in TX Mode)

P_MODE	Function (TX Mode)
0	Manchester modulator on (default)
1	Manchester modulator off (NRZ mode)

### Control Register 3 (ADR 2)

**Table 23.** Control Register 3 (Function of Bit 3 and Bit 2)

FR8	FR7	Function
0	0	FREQ3 = 0
0	1	FREQ3 = 128
1	0	FREQ3 = 256 (default)
1	1	FREQ3 = 384

Note: Tuning of  $f_{RF}$  MSB's

**Table 24.** Control Register 3 (Function of Bit 1)

VSOUT_EN	Function
0	Output voltage power supply for external devices off (pin VSOUT)
1	Output voltage power supply for external devices on (default)

Note: This bit is set to 1 if the Bit-check is ok (RX\_Polling, RX mode), an event at pin T1, T2, T3, T4 or T5 occurs or the bit Power\_On in the status register is 1.  
Setting VSOUT\_EN = 0 in AUX mode is not allowed

**Table 25.** Control Register 3 (Function of Bit 0)

CLK_ON	Function
0	Clock output off (pin CLK)
1	Clock output on (default)

Note: This bit is set to 1 if the Bit-check is ok (RX\_Polling, RX mode), an event at pin T1, T2, T3, T4 or T5 occurs or the bit Power\_On in the status register is 1.

### Control Register 4 (ADR 3)

**Table 26.** Control Register 4 (Function of Bit 7)

ASK_NFSK	Function
0	FSK mode (default)
1	ASK mode

**Table 27.** Control Register 4 (Function of Bit 6, Bit 5, Bit 4, Bit 3 and Bit 2)

Sleep4	Sleep3	Sleep2	Sleep1	Sleep0	Function Sleep ( $T_{Sleep} = Sleep \times 1024 \times T_{DCLK} \times X_{Sleep}$ )
0	0	0	0	0	0
0	0	0	0	1	1
.	.	.	.	.	
0	1	0	1	0	10 ( $T_{Sleep} = 10 \times 1024 \times T_{DCLK} \times X_{Sleep}$ ) (default)
.	.	.	.	.	
1	1	1	1	1	31

**Table 28.** Control Register 4 (Function of Bit 1)

XSleep	Function
0	$X_{Sleep} = 1$ ; extended $T_{Sleep}$ off (default)
1	$X_{Sleep} = 8$ ; extended $T_{Sleep}$ on

**Table 29.** Control Register 4 (Function of Bit 0)

XLim	Function
0	$X_{Lim} = 1$ ; extended $T_{Lim\_min}$ , $T_{Lim\_max}$ off (default)
1	$X_{Lim} = 2$ ; extended $T_{Lim\_min}$ , $T_{Lim\_max}$ on

## Control Register 5 (ADR 4)

**Table 30.** Control Register 5 (Function of Bit 7 and Bit 6)

BitChk1	BitChk0	Function
0	0	$N_{Bit-check} = 0$ (0 bits checked during Bit-check)
0	1	$N_{Bit-check} = 3$ (3 bits checked during Bit-check (default))
1	0	$N_{Bit-check} = 6$ (6 bits checked during Bit-check)
1	1	$N_{Bit-check} = 9$ (9 bits checked during Bit-check)

**Table 31.** Control Register 5 (Function of Bit 5, Bit 4, Bit 3, Bit 2, Bit 1 and Bit 0 in RX Mode)

Lim_min5	Lim_min4	Lim_min3	Lim_min2	Lim_min1	Lim_min0	Function (RX Mode) Lim_min (Lim_min < 10 are not applicable) ( $T_{Lim\_min} = Lim\_min \times T_{XDCLK}$ )
0	0	1	0	1	0	10
0	0	1	0	1	1	11
.	.	.	.	.	.	
0	1	0	0	0	0	16 ( $T_{Lim\_min} = 16 \times T_{XDCLK}$ ) (default)
.	.	.	.	.	.	
1	1	1	1	1	1	63

**Table 32.** Control Register 5 (Function of Bit 5, Bit 4, Bit 3, Bit 2, Bit 1 and Bit 0 in TX Mode)

Lim_min5	Lim_min4	Lim_min3	Lim_min2	Lim_min1	Lim_min0	Function (TX Mode) Lim_min (Lim_min < 10 are not applicable) (TX_Baudrate = 1/((Lim_min + 1) × T <sub>XDCLK</sub> × 2)
0	0	1	0	1	0	10
0	0	1	0	1	1	11
.	.	.	.	.	.	
0	1	0	0	0	0	16 (TX_Baudrate = 1/((16 + 1) × T <sub>XDCLK</sub> × 2) (default)
.	.	.	.	.	.	
1	1	1	1	1	1	63

**Control Register 6 (ADR 5)**

**Table 33.** Control Register 6 (Function of Bit 7 and Bit 6)

Baud1	Baud0	Function
0	0	Baud-rate range 0 (B0) 1.0 kBaud to 2.5 kBaud; T <sub>XDCLK</sub> = 8 × T <sub>DCLK</sub> × X <sub>Lim</sub>
0	1	Baud-rate range 1 (B1) 2.0 kBaud to 5.0 kBaud; T <sub>XDCLK</sub> = 4 × T <sub>DCLK</sub> × X <sub>Lim</sub>
1	0	Baud-rate range 2 (B2) 4.0 kBaud to 10.0 kBaud; T <sub>XDCLK</sub> = 2 × T <sub>DCLK</sub> × X <sub>Lim</sub> ; (default)
1	1	Baud-rate range 3 (B3) 8.0 kBaud to 20.0 kBaud; T <sub>XDCLK</sub> = 1 × T <sub>DCLK</sub> × X <sub>Lim</sub> ; Note that the receiver is not working with >10 kBaud in ASK mode

**Table 34.** Control Register 6 (Function of Bit 5, Bit 4, Bit 3, Bit 2, Bit 1 and Bit 0)

Lim_max5	Lim_max4	Lim_max3	Lim_max2	Lim_max1	Lim_max0	Function Lim_max (Lim_max < 12 Are Not Applicable) (T <sub>Lim_max</sub> = (Lim_max - 1) × T <sub>XDCLK</sub> )
0	0	1	1	0	0	12
0	0	1	1	0	1	13
.	.	.	.	.	.	
0	1	1	1	0	0	28 (T <sub>Lim_max</sub> = (28 - 1) × T <sub>XDCLK</sub> ) (default)
.	.	.	.	.	.	
1	1	1	1	1	1	63

## Status Register

The status register indicates the current status of the transceiver and is readable via the 4-wire serial interface. Setting Power\_On or P\_On\_Aux or an event on ST1, ST2, ST3, ST4 or ST5 is indicated by an IRQ.

Reading the status register resets the bits Power\_On, Low\_Batt, P\_On\_Aux and the IRQ

### Status Register (ADR 8)

**Table 35.** Status Register

Status Bit	Function
ST5	Status of pin T5 Pin T5 = 0 →ST5 = 1 Pin T5 = 1 →ST5 = 0 (see Figure 29 on page 41)
ST4	Status of pin T4 Pin T4 = 0 →ST4 = 1 Pin T4 = 1 →ST4 = 0 (see Figure 29 on page 41)
ST3	Status of pin T3 Pin T3 = 0 →ST3 = 1 Pin T3 = 1 →ST3 = 0 (see Figure 29 on page 41)
ST2	Status of pin T2 Pin T2 = 0 →ST2 = 1 Pin T2 = 1 →ST2 = 0 (see Figure 29 on page 41)
ST1	Status of pin T1 Pin T1 = 0 →ST1 = 1 Pin T1 = 1 →ST1 = 0 (see Figure 29 on page 41)
Power_On	Indicates that the transceiver was woken up by pin PWR_ON (rising edge on pin PWR_ON). During Power_On = 1, the bits VSOUT_EN and CLK_ON in control register 3 are set to 1. (see Figure 30 on page 42)
Low_Batt	Indicates that output voltage on pin VSOUT is too low ( $V_{VSOUT} < 2.38$ V typically) (see Figure 31 on page 43)
P_On_Aux	Indicates that the auxiliary supply voltage on pin VAUX is high enough to operate. State transition: a) OFF mode →AUX mode (see Figure 22 on page 28) b) Idle mode (VSOUT = VS1) →Idle mode (VSOUT = V_REG2) (see Figure 32 on page 44)

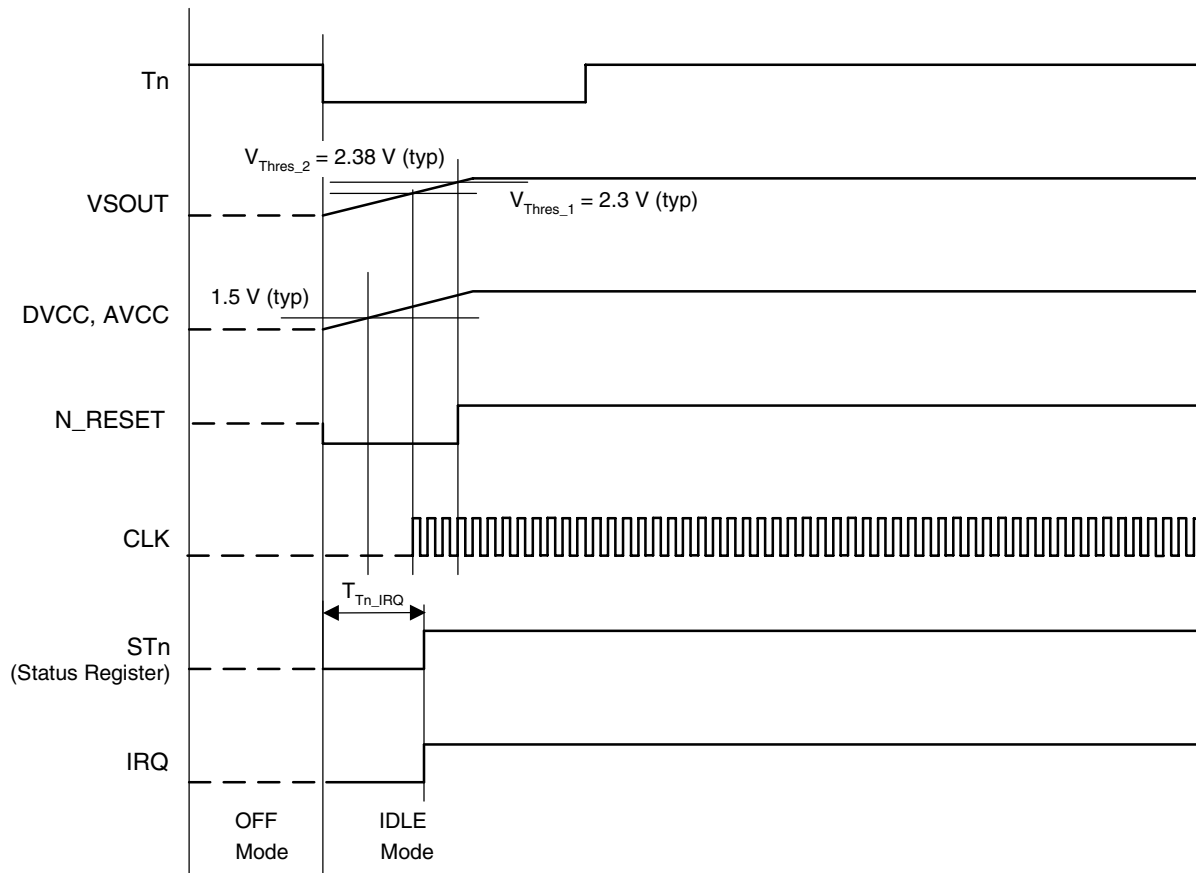
## Pin Tn

To switch the transceiver from OFF to Idle mode, pin Tn must set to 0 (maximum  $0.2 \times V_{VS2}$ ) for at least  $T_{Tn\_IRQ}$  (see Figure 28). The transceiver recognize the negative edge, sets pin N\_RESET to low and switches on DVCC, AVCC and the power supply for external devices VSOUT.

If  $V_{DVCC}$  exceeds 1.5 V (typically) and the XTO is settled, the digital control logic is active and sets the status bit STn to 1 and an interrupt is issued ( $T_{Tn\_IRQ}$ ).

After the voltage on pin VSOUT exceeds 2.3 V (typically) and the start-up time of the XTO is elapsed the output clock on pin CLK is available. Because the enabling of pin CLK is asynchronous the first clock cycle may be incomplete. N\_RESET is set to high if  $V_{VSOUT}$  exceeds 2.38 V (typically) and the XTO is settled.

**Figure 28.** Timing Pin Tn, Status Bit STn





If the transceiver is in any active mode (Idle, AUX, TX, RX, RX\_Polling), an integrated debounce logic is active. If there is an event on pin T<sub>n</sub> a debounce counter is set to 0 ( $T = 0$ ) and started. The status is updated, an interrupt is issued and the debounce counter is stopped after reaching the counter value  $T = 8195 \times T_{DCLK}$ .

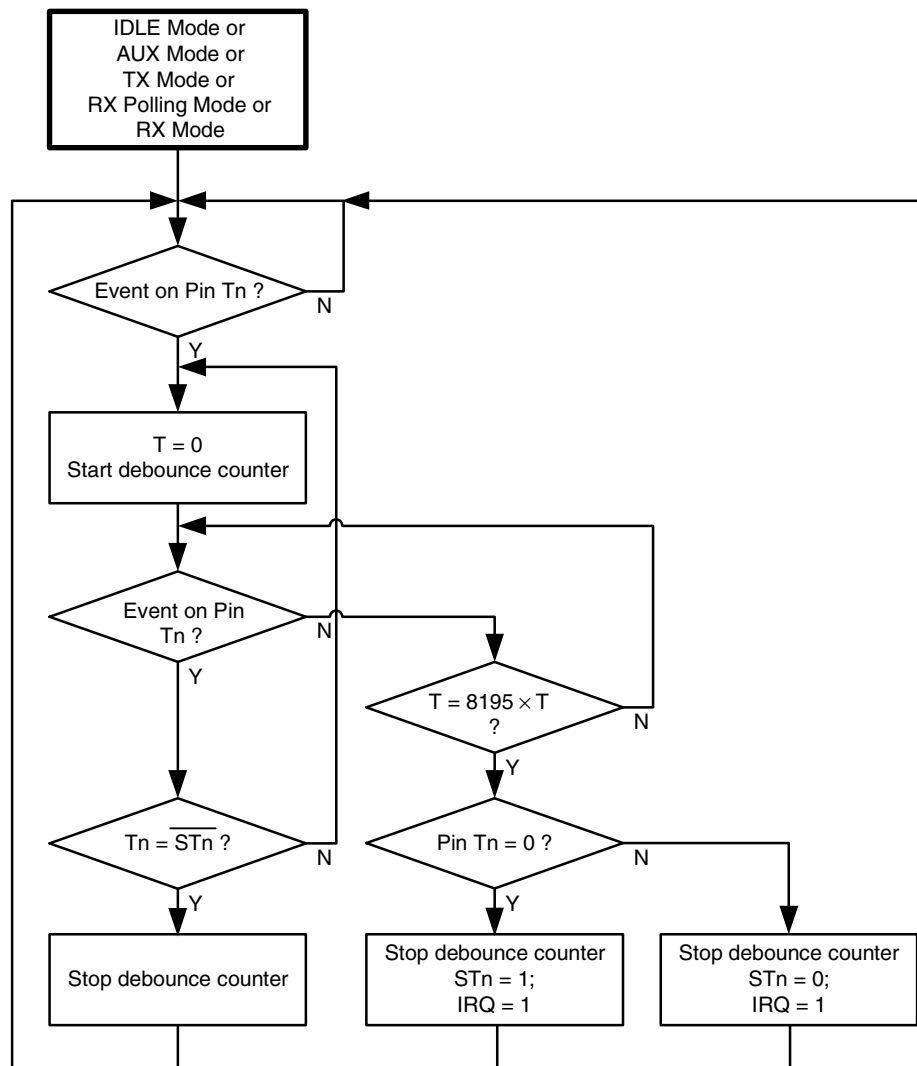
An event on the same key input before reaching  $T = 8195 \times T_{DCLK}$  stops the debounce counter. An event on an other key input before reaching  $T = 8195 \times T_{DCLK}$  resets and restarts the debounce counter.

While the debounce counter is running, the bits VSOUT\_EN and CLK\_ON in control register 3 are set to 1.

The interrupt is deleted after reading the status register or executes the command Delete\_IRQ.

If a pin T<sub>n</sub> is not used, it can be left open because of an internal pull-up resistor (typically 50 kΩ).

**Figure 29.** Timing Flow Pin T<sub>n</sub>, Status Bit ST<sub>n</sub>



## Pin PWR\_ON

To switch the transceiver from OFF to Idle mode, pin PWR\_ON must set to 1 (minimum  $0.8 \times V_{VS2}$ ) for at least  $T_{PWR\_ON}$  (see Figure 30). The transceiver recognize the positive edge, sets pin N\_RESET to low and switches on DVCC, AVCC and the power supply for external devices VSOUT.

If  $V_{DVCC}$  exceeds 1.5 V (typically) and the XTO is settled, the digital control logic is active and sets the status bit Power\_On to 1 and an interrupt is issued ( $T_{PWR\_ON\_IRQ\_1}$ ).

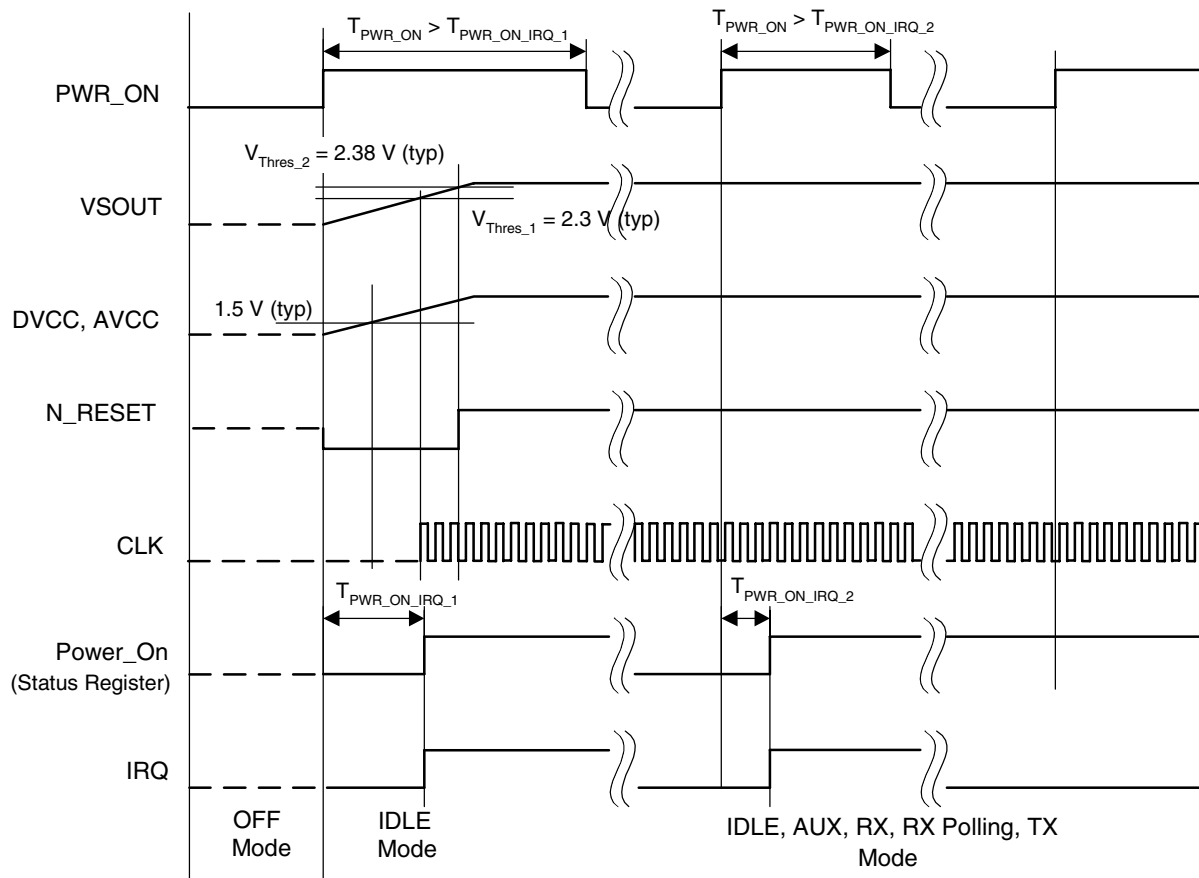
After the voltage on pin VSOUT exceeds 2.3 V (typically) and the start-up time of the XTO is elapsed the output clock on pin CLK is available. Because the enabling of pin CLK is asynchronous the first clock cycle may be incomplete. N\_RESET is set to high if  $V_{VSOUT}$  exceeds 2.38 V (typically) and the XTO is settled.

If the transceiver is in any active mode (Idle, AUX, RX, RX\_Polling, TX), a positive edge on pin PWR\_ON sets Power\_On to 1 (after  $T_{PWR\_ON\_IRQ\_2}$ ). The state transition Power\_On 0  $\rightarrow$  1 generates an interrupt. If Power\_On is still 1 during the positive edge on pin PWR\_ON no interrupt is issued. Power\_On and the interrupt is deleted after reading the status register.

During Power\_On = 1, the bits VSOUT\_EN and CLK\_ON in control register 3 are set to 1.

Note: It is not possible to set the transceiver to OFF mode by setting pin PWR\_ON to 0. If pin PWR\_ON is not used, it must be connected to GND.

**Figure 30.** Timing Pin PWR\_ON, Status Bit Power\_On

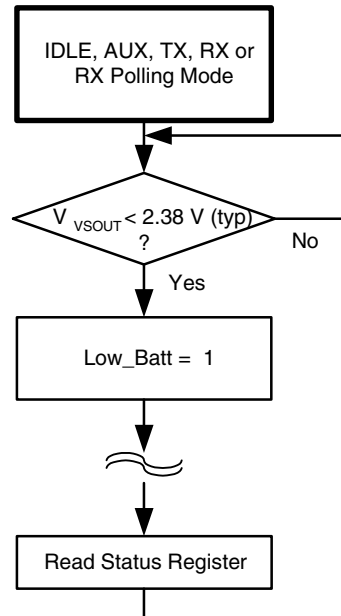


## Low Battery Indicator

The status bit Low\_Batt is set to 1 if the voltage on pin VSOUT  $V_{VSOUT}$  drops under 2.38 V (typically).

Low\_Batt is set to 0 if  $V_{VSOUT}$  exceeds  $V_{Thres\_2}$  and the status register is read via the 4-wire serial interface (see Figure 23 on page 30).

**Figure 31.** Timing Status Bit Low\_Batt



## Pin VAUX

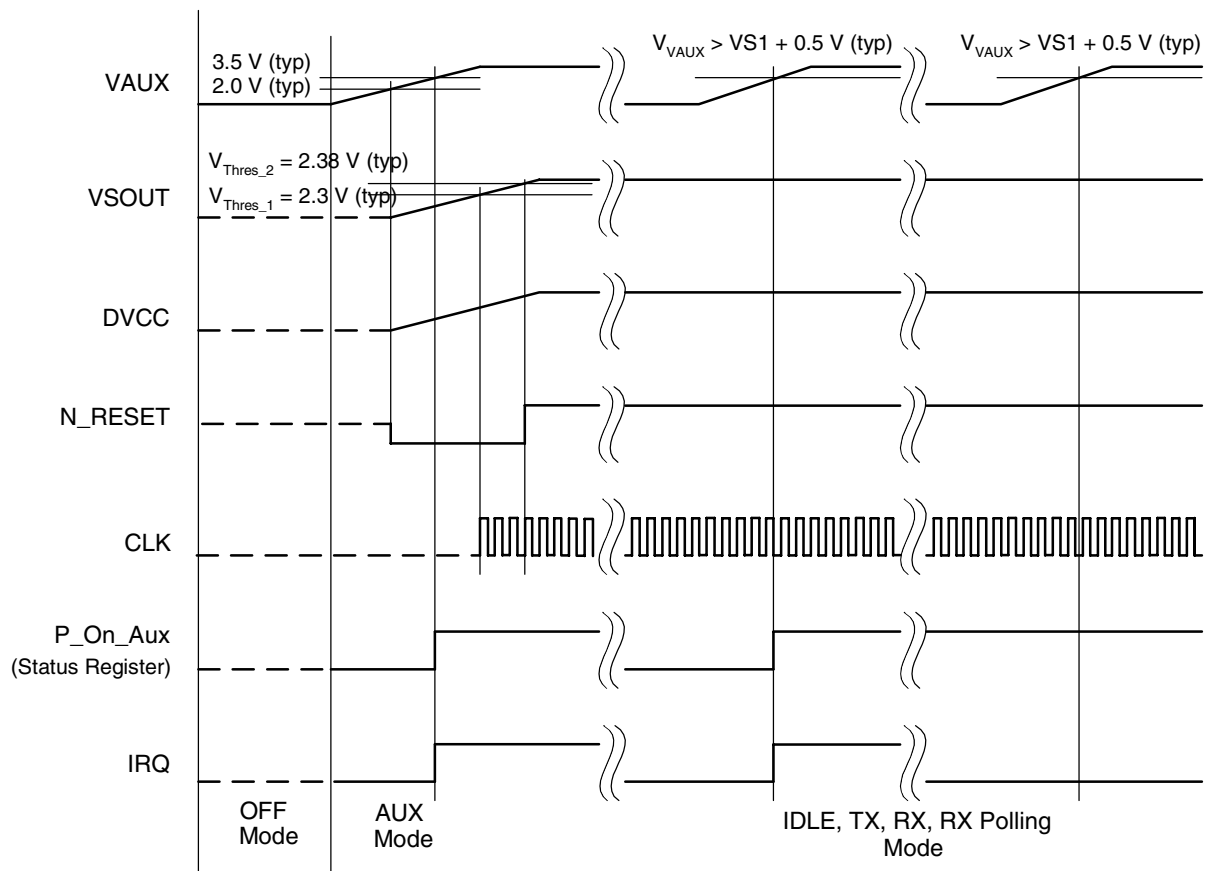
To switch the transceiver from OFF to AUX mode, the voltage on pin VAUX  $V_{VAUX}$  must exceed 3.5 V (typically) (see Figure 32). If  $V_{VAUX}$  exceeds 2 V (typically) pin N\_RESET is set to low, DVCC and the power supply for external devices VSOUT are switched on.

If  $V_{VAUX}$  exceeds 3.5 V (typically) the status bit P\_On\_Aux is set to 1 and an interrupt is issued.

After the voltage on pin VSOUT exceeds 2.3 V (typically) and the start-up time of the XTO is elapsed the output clock on pin CLK is available. Because the enabling of pin CLK is asynchronous the first clock cycle may be incomplete. N\_RESET is set to high if  $V_{VSOUT}$  exceeds 2.38 V (typically) and the XTO is settled.

If the transceiver is in any active mode (Idle, TX, RX, RX\_Polling), a positive edge on pin VAUX and  $V_{VAUX} > VS1 + 0.5 V$  sets P\_On\_Aux to 1. The state transition P\_On\_Aux 0 → 1 generates an interrupt. If P\_On\_Aux is still 1 during the positive edge on pin VAUX no interrupt is issued. P\_On\_Aux and the interrupt is deleted after reading the status register.

**Figure 32.** Timing Pin VAUX, Status Bit P\_On\_Aux



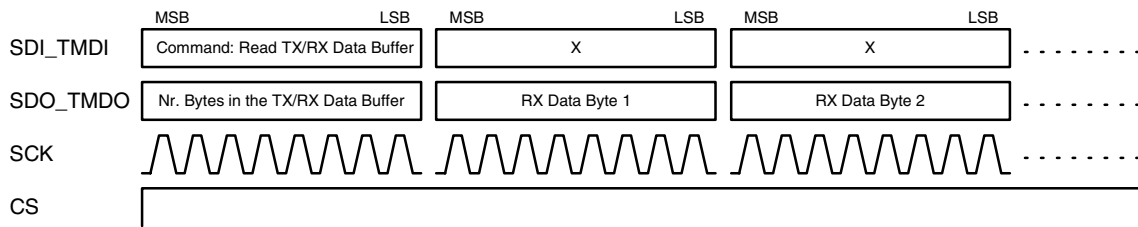
## Transceiver Configuration

The configuration of the transceiver takes place via a 4-wire serial interface (CS, SCK, SDI\_TMDI, SDO\_TMDO) and is organized in 8-bit units. The configuration is initiated with a 8-bit command. While shifting the command into pin SDI\_TMDI, the number of bytes in the TX/RX data buffer are available on pin SDO\_TMDO. The read and write commands are followed by one or more 8-bit data units. Each 8-bit data transmission begins with the MSB. The serial interface is in reset state if the level on pin CS = Low.

### Command: Read TX/RX Data Buffer

During a RX operation the user can read the received bytes in the TX/RX data buffer successively.

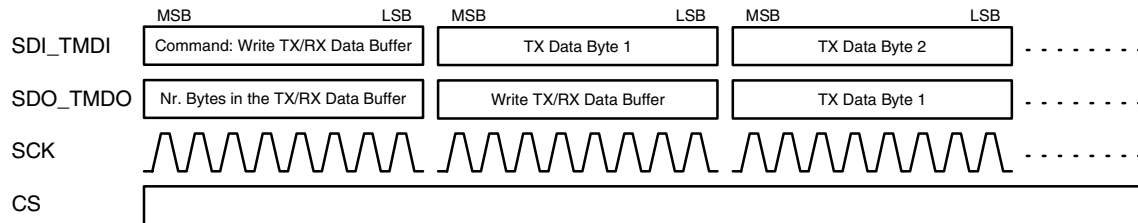
Figure 33. Read TX/RX Data Buffer



### Command: Write TX/RX Data Buffer

During a TX operation the user can write the bytes in the TX/RX data buffer successively. An echo of the command and the TX data bytes are provided for the microcontroller on pin SDO\_TMDO.

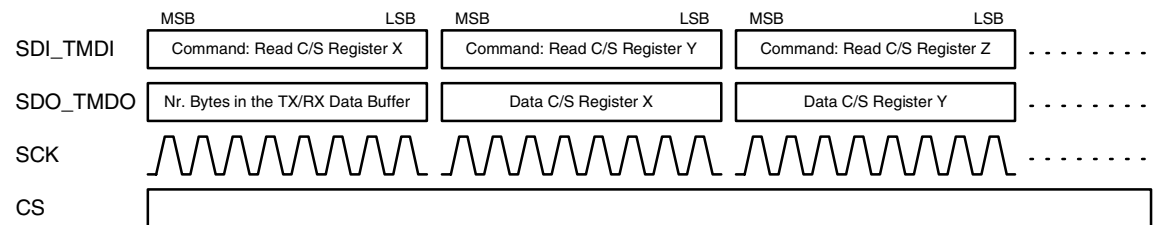
Figure 34. Write TX/RX Data Buffer



### Command: Read Control/Status Register

The control and status registers can be read individually or successively.

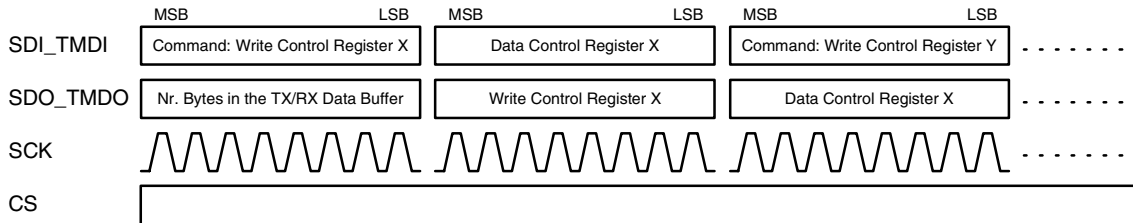
Figure 35. Read Control/Status Register



**Command:  
Write Control Register**

The control registers can be written individually or successively. An echo of the command and the data bytes are provided for the microcontroller on pin SDO\_TMDO.

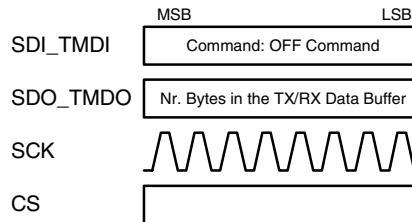
**Figure 36.** Write Control Register



**Command:  
OFF Command**

If AVCC\_EN in control register 1 is 0, the input level on pin PWR\_ON is low and on the key inputs Tn is high, the OFF command sets the transceiver in the OFF mode.

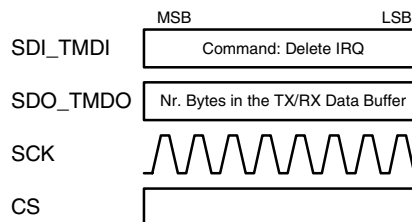
**Figure 37.** OFF Command



**Command: Delete IRQ**

The delete IRQ command sets pin IRQ to low.

**Figure 38.** Delete IRQ



**Command Structure**

The three most significant bits of the command (Bit 5 to Bit 7) indicates the command type. Bit 0 to Bit 4 describes the target address when reading or writing a control or status register. In all other commands Bit 0 to Bit 4 have no effect and should be set to 0 for compatibility reasons with future products.

**Table 36.** Command Structure

Command	MSB								LSB
	Bit 7	Bit 6	Bit 5	Bit 4	Bit 3	Bit 2	Bit 1	Bit 0	
Read TX/RX data buffer	0	0	0	x	x	x	x	x	
Write TX/RX data buffer	0	0	1	x	x	x	x	x	
Read control/status register	0	1	0	A4	A3	A2	A1	A0	
Write control register	0	1	1	A4	A3	A2	A1	A0	
OFF command	1	0	0	X	X	X	X	X	
Delete IRQ	1	0	1	X	X	X	X	X	
Not used	1	1	0	X	X	X	X	X	
Not used	1	1	1	X	X	X	X	X	

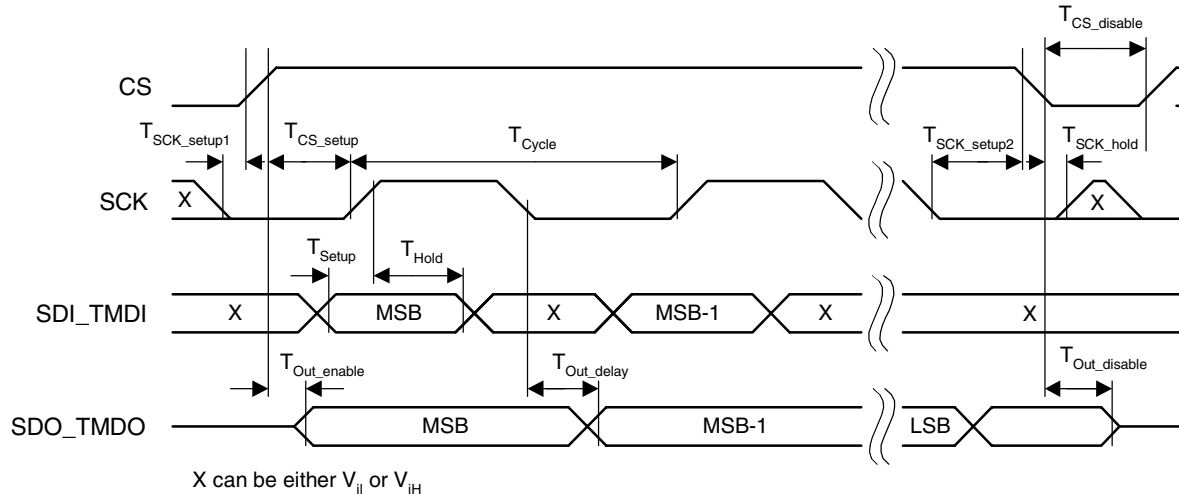
## 4-wire Serial Interface

The 4-wire serial interface consists of the Chip Select (CS), the Serial Clock (SCK), the Serial Data Input (SDI\_TMDI) and the Serial Data Output (SDO\_TMDO). Data is transmitted/received bit by bit in synchronization with the serial clock.

Note: If the output level on pin N\_RESET is low, no data communication with the microcontroller is possible.

When CS is low and the transparent mode is inactive ( $T\_MODE = 0$ ), SDO\_TMDO is in a high-impedance state. When CS is low and the transparent mode is active ( $T\_MODE = 1$ ), the RX data stream is available on pin SDO\_TMDO.

**Figure 39.** Serial Timing



## Operation Modes

### RX Operation

The transceiver is set to RX operation with the bits OPM0 and OPM1 in control register 1

**Table 37.** Control Register 1

OPM1	OPM0	Function
1	0	RX polling mode
1	1	RX mode

The transceiver is designed to consume less than 1 mA in RX operation while being sensitive to signals from a corresponding transmitter. This is achieved via the polling circuit. This circuit enables the signal path periodically for a short time. During this time the Bit-check logic verifies the presence of a valid transmitter signal. Only if a valid signal is detected the transceiver remains active and transfers the data to the connected microcontroller. This transfer takes place either via the TX/RX data buffer or via the pin SDO\_TMDO. If there is no valid signal present the transceiver is in sleep mode most of the time resulting in low current consumption. This condition is called RX polling mode. A connected microcontroller can be disabled during this time.

All relevant parameters of the polling logic can be configured by the connected microcontroller. This flexibility enables the user to meet the specifications in terms of current consumption, system response time, data rate etc.

In RX mode the RF transceiver is enabled permanently and the Bit-check logic verifies the presence of a valid transmitter signal. If a valid signal is detected the transceiver transfers the data to the connected microcontroller. This transfer takes place either via the TX/RX data buffer or via the pin SDO\_TMDO.

### RX Polling Mode

If the transceiver is in RX polling mode it stays in a continuous cycle of three different modes. In sleep mode the RF transceiver is disabled for the time period  $T_{\text{Sleep}}$  while consuming low current of  $I_S = I_{\text{IDLE}_X}$ . During the start-up period,  $T_{\text{Startup\_PLL}}$  and  $T_{\text{Startup\_Sig\_Proc}}$ , all signal processing circuits are enabled and settled. In the following Bit-check mode, the incoming data stream is analyzed bit by bit contra a valid transmitter signal. If no valid signal is present, the transceiver is set back to sleep mode after the period  $T_{\text{Bit-check}}$ . This period varies check by check as it is a statistical process. An average value for  $T_{\text{Bit-check}}$  is given in the electrical characteristics. During  $T_{\text{Startup\_PLL}}$  the current consumption is  $I_S = I_{\text{RX}_X}$ . During  $T_{\text{Startup\_Sig\_Proc}}$  and  $T_{\text{Bit-check}}$  the current consumption is  $I_S = I_{\text{Startup\_Sig\_Proc}_X}$ . The condition of the transceiver is indicated on pin RX\_ACTIVE (see Figure 40 on page 50 and Figure 41 on page 51). The average current consumption in RX polling mode  $I_P$  is different in 1 battery application, 2 battery application or car application. To calculate  $I_P$  the index X must be replaced by VS1, 2 in 1 battery application, VS2 in 2 battery application or VS2, VAUX in car application (see section "Electrical Characteristics")

$$I_P = \frac{I_{\text{IDLE}_X} \times T_{\text{Sleep}} + I_{\text{Startup\_PLL}_X} \times T_{\text{Startup\_PLL}} + I_{\text{RX}_X} \times (T_{\text{Startup\_Sig\_Proc}} + T_{\text{Bitcheck}})}{T_{\text{Sleep}} + T_{\text{Startup\_PLL}} + T_{\text{Startup\_Sig\_Proc}} + T_{\text{Bit-check}}}$$



To save current it is recommended CLK and  $V_{VSOUT}$  be disabled during RX polling mode.  $I_P$  does not include the current of the Microcontroller\_Interface  $I_{VSINT}$  and the current of an external device connected to pin VSOUT (e.g., microcontroller). If CLK and/or VSOUT is enabled during RX polling mode the current consumption is calculated as follows:

$$I_{S\_Poll} = I_P + I_{VSINT} + I_{EXT}$$

During  $T_{Sleep}$ ,  $T_{Startup\_PLL}$  and  $T_{Startup\_Sig\_Proc}$  the transceiver is not sensitive to a transmitter signal. To guarantee the reception of a transmitted command the transmitter must start the telegram with an adequate preburst. The required length of the preburst  $T_{Presturb}$  depends on the polling parameters  $T_{Sleep}$ ,  $T_{Startup\_PLL}$ ,  $T_{Startup\_Sig\_Proc}$  and  $T_{Bit\_check}$ . Thus,  $T_{Bit\_check}$  depends on the actual bit rate and the number of bits ( $N_{Bit\_check}$ ) to be tested

$$T_{Presturb} \geq T_{Sleep} + T_{Startup\_PLL} + T_{Startup\_Sig\_Proc} + T_{Bit\_check}$$

### Sleep Mode

The length of period  $T_{Sleep}$  is defined by the 5-bit word sleep in control register 4, the extension factor  $X_{Sleep}$  defined by the bit XSleep in control register 4 and the basic clock cycle  $T_{DCLK}$ . It is calculated to be:

$$T_{Sleep} = Sleep \times 1024 \times T_{DCLK} \times X_{Sleep}$$

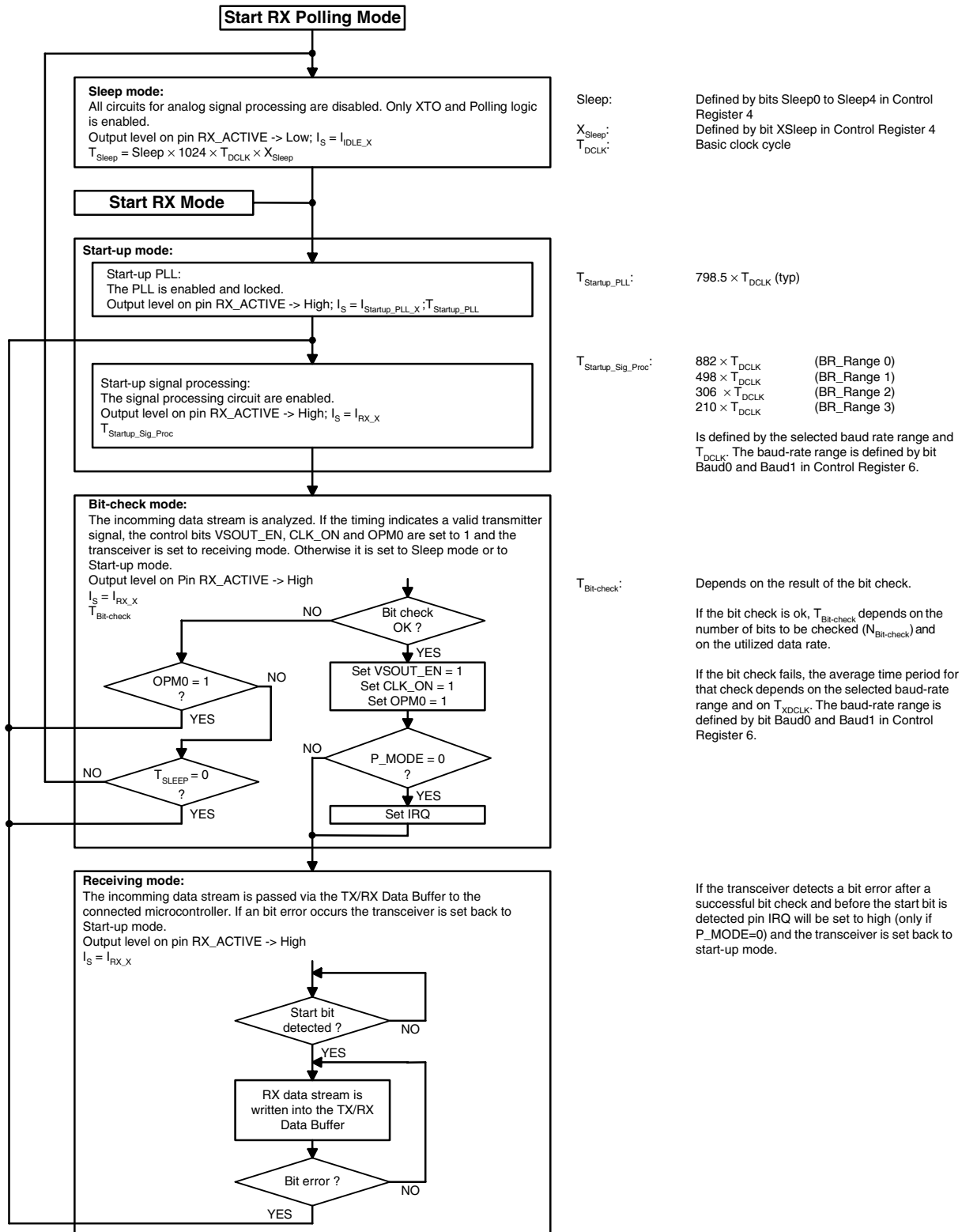
In US and European applications, the maximum value of  $T_{Sleep}$  is about 38 ms if  $X_{Sleep}$  is set to 1 (which is done by setting the bit XSleep in control register 4 to 0). The time resolution is about 1.2 ms in that case. The sleep time can be extended to about 300 ms by setting  $X_{Sleep}$  to 8 (which is done by setting XSleep in control register 4 to 1), the time resolution is then about 9.6 ms.

### Start-up Mode

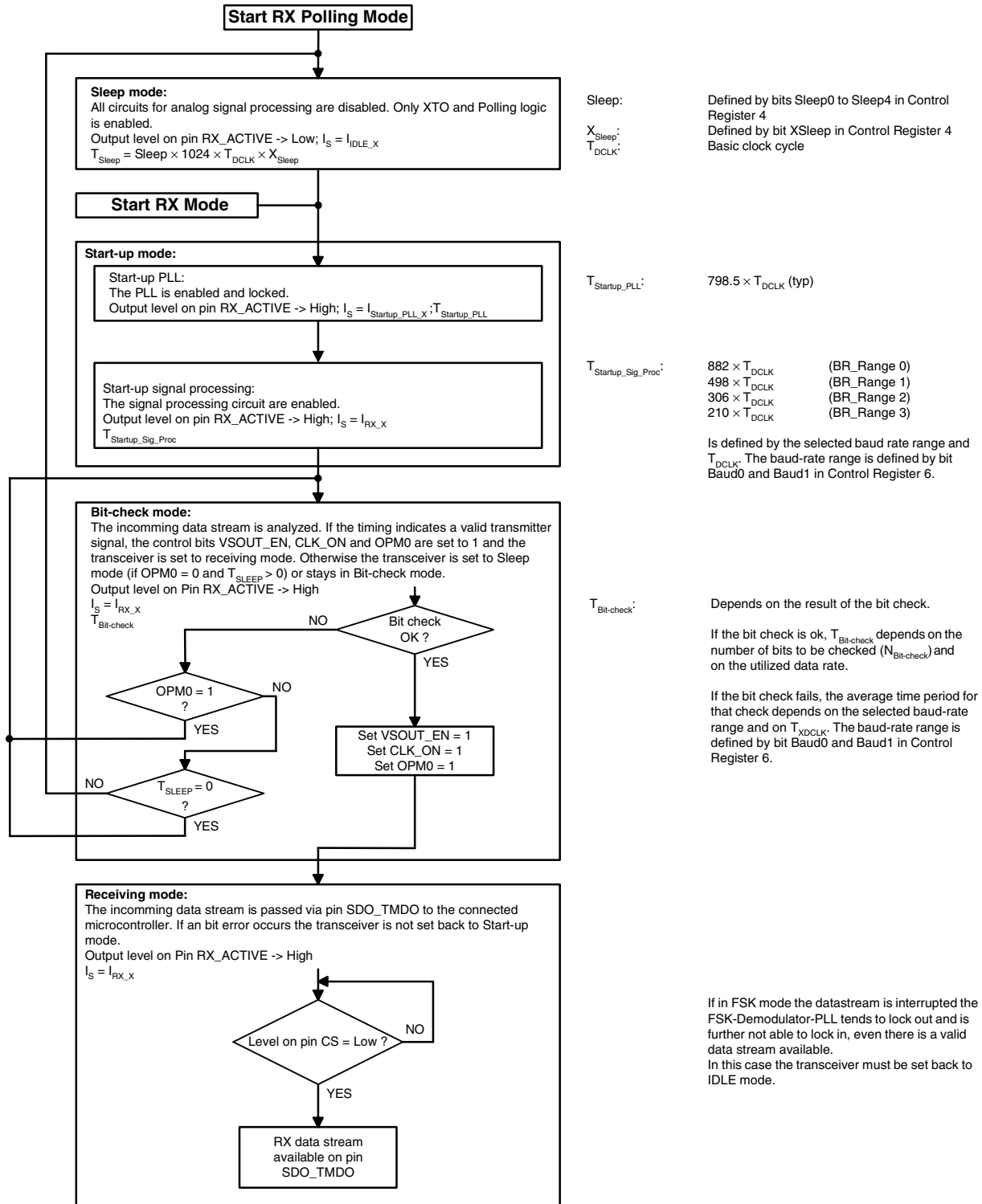
During  $T_{Startup\_PLL}$  the PLL is enabled and starts up. If the PLL is locked, the signal processing circuit starts up ( $T_{Startup\_Sig\_Proc}$ ). After the start-up time all circuits are in stable condition and ready to receive.



**Figure 40.** Flow Chart Polling Mode/RX Mode ( $T\_MODE = 1$ , Transparent Mode Inactive)



**Figure 41.** Flow Chart Polling Mode/RX Mode (T\_MODE = 1, Transparent Mode Active)



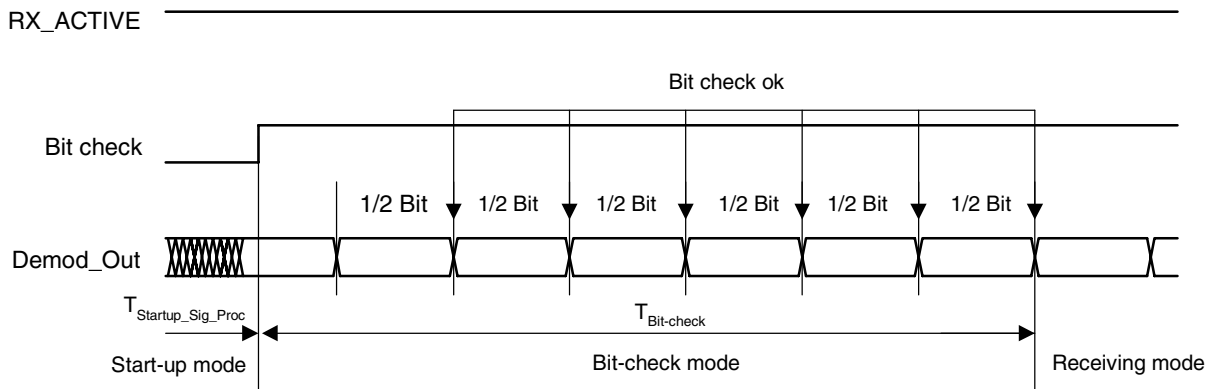
### Bit-check Mode

In Bit-check mode the incoming data stream is examined to distinguish between a valid signal from a corresponding transmitter and signals due to noise. This is done by subsequent time frame checks where the distance between 2 signal edges are continuously compared to a programmable time window. The maximum count of this edge to edge test before the transceiver switches to receiving mode is also programmable.

### Configuration the Bit-check

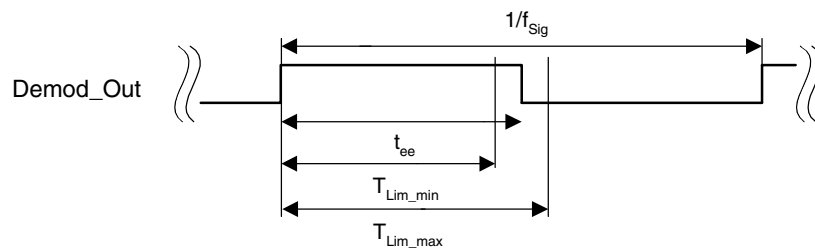
Assuming a modulation scheme that contains 2 edges per bit, two time frame checks are verifying one bit. This is valid for Manchester, Bi-phase and most other modulation schemes. The maximum count of bits to be checked can be set to 0, 3, 6 or 9 bits via the variable  $N_{\text{Bit-check}}$  in control register 5. This implies 0, 6, 12 and 18 edge to edge checks respectively. If  $N_{\text{Bit-check}}$  is set to a higher value, the transceiver is less likely to switch to receiving mode due to noise. In the presence of a valid transmitter signal, the Bit-check takes less time if  $N_{\text{Bit-check}}$  is set to a lower value. In RX polling mode, the Bit-check time is not dependent on  $N_{\text{Bit-check}}$ . Figure 42 shows an example where 3 bits are tested successful.

**Figure 42.** Timing Diagram for Complete Successful Bit-check (Number of Checked Bits: 3)



According to Figure 43, the time window for the Bit-check is defined by two separate time limits. If the edge to edge time  $t_{ee}$  is in between the lower Bit-check limit  $T_{\text{Lim\_min}}$  and the upper Bit-check limit  $T_{\text{Lim\_max}}$ , the check will be continued. If  $t_{ee}$  is smaller than limit  $T_{\text{Lim\_min}}$  or exceeds  $T_{\text{Lim\_max}}$ , the Bit-check will be terminated and the transceiver switches to sleep mode.

**Figure 43.** Valid Time Window for Bit-check



For the best noise immunity it is recommended to use a low span between  $T_{Lim\_min}$  and  $T_{Lim\_max}$ . This is achieved using a fixed frequency at a 50% duty cycle for the transmitter preburst. A '11111...' or a '10101...' sequence in Manchester or Bi-phase is a good choice concerning that advice. A good compromise between sensitivity and susceptibility to noise regarding the expected edge to edge time  $t_{ee}$  is a time window of  $\pm 38\%$ , to get the maximum sensitivity the time window should be  $\pm 50\%$  and then  $N_{Bit-check} \geq 6$ . Using preburst patterns that contain various edge to edge time periods, the Bit-check limits must be programmed according to the required span.

The Bit-check limits are determined by means of the formula below:

$$T_{Lim\_min} = Lim\_min \times T_{XDCLK}$$

$$T_{Lim\_max} = (Lim\_max - 1) \times T_{XDCLK}$$

$Lim\_min$  is defined by the bits  $Lim\_min\ 0$  to  $Lim\_min\ 5$  in control register 5.

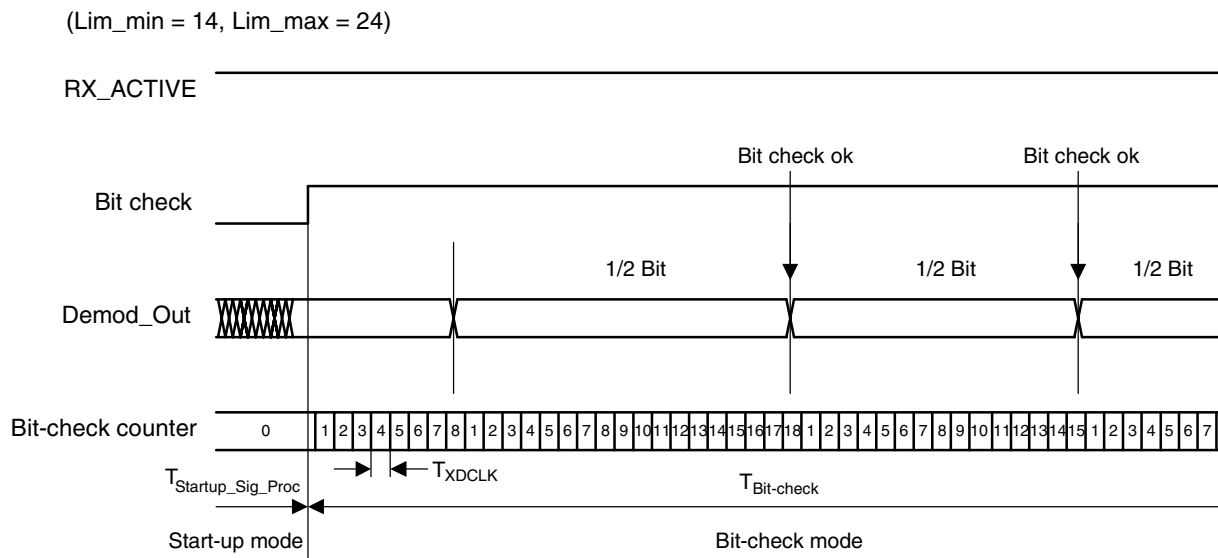
$Lim\_max$  is defined by the bits  $Lim\_max\ 0$  to  $Lim\_max\ 5$  in control register 6.

Using the above formulas,  $Lim\_min$  and  $Lim\_max$  can be determined according to the required  $T_{Lim\_min}$ ,  $T_{Lim\_max}$  and  $T_{XDCLK}$ . The time resolution defining  $T_{Lim\_min}$  and  $T_{Lim\_max}$  is  $T_{XDCLK}$ . The minimum edge to edge time  $t_{ee}$  is defined according to the section "Receiving Mode". The lower limit should be set to  $Lim\_min \geq 10$ . The maximum value of the upper limit is  $Lim\_max = 63$ .

Figure 44, Figure 45 on page 54, and Figure 46 on page 54 illustrate the Bit-check for the Bit-check limits  $Lim\_min = 14$  and  $Lim\_max = 24$ . The signal processing circuits are enabled during  $T_{Startup\_PLL}$  and  $T_{Startup\_Sig\_Proc}$ . The output of the ASK/FSK demodulator (Demod\_Out) is undefined during that period. When the Bit-check becomes active, the Bit-check counter is clocked with the cycle  $T_{XDCLK}$ .

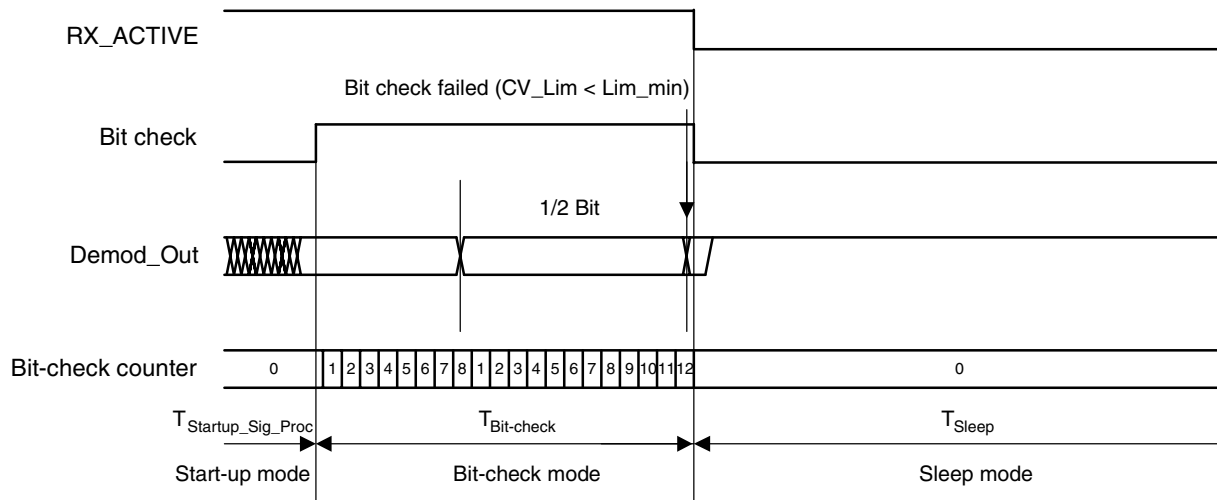
Figure 44 shows how the Bit-check proceeds if the Bit-check counter value  $CV\_Lim$  is within the limits defined by  $Lim\_min$  and  $Lim\_max$  at the occurrence of a signal edge. In Figure 45 on page 54 the Bit-check fails as the value  $CV\_Lim$  is lower than the limit  $Lim\_min$ . The Bit-check also fails if  $CV\_Lim$  reaches  $Lim\_max$ . This is illustrated in Figure 46 on page 54.

**Figure 44.** Timing Diagram During Bit-check



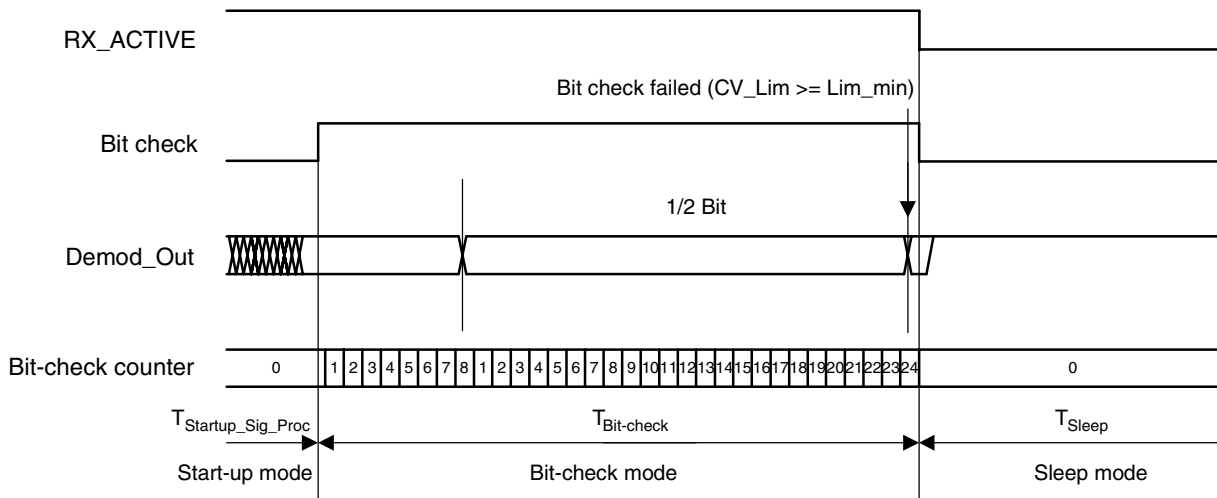
**Figure 45.** Timing Diagram for Failed Bit-check (Condition  $CV\_Lim < Lim\_min$ )

( $Lim\_min = 14, Lim\_max = 24$ )



**Figure 46.** Timing Diagram for Failed Bit-check (Condition:  $CV\_Lim \geq Lim\_max$ )

( $Lim\_min = 14, Lim\_max = 24$ )



**Duration of the Bit-check**

If no transmitter is present during the Bit-check, the output of the ASK/FSK demodulator delivers random signals. The Bit-check is a statistical process and  $T_{Bit-check}$  varies for each check. Therefore, an average value for  $T_{Bit-check}$  is given in the electrical characteristics.  $T_{Bit-check}$  depends on the selected baud rate range and on  $T_{XDCLK}$ . A higher baud-rate range causes a lower value for  $T_{Bit-check}$  resulting in a lower current consumption in RX polling mode.

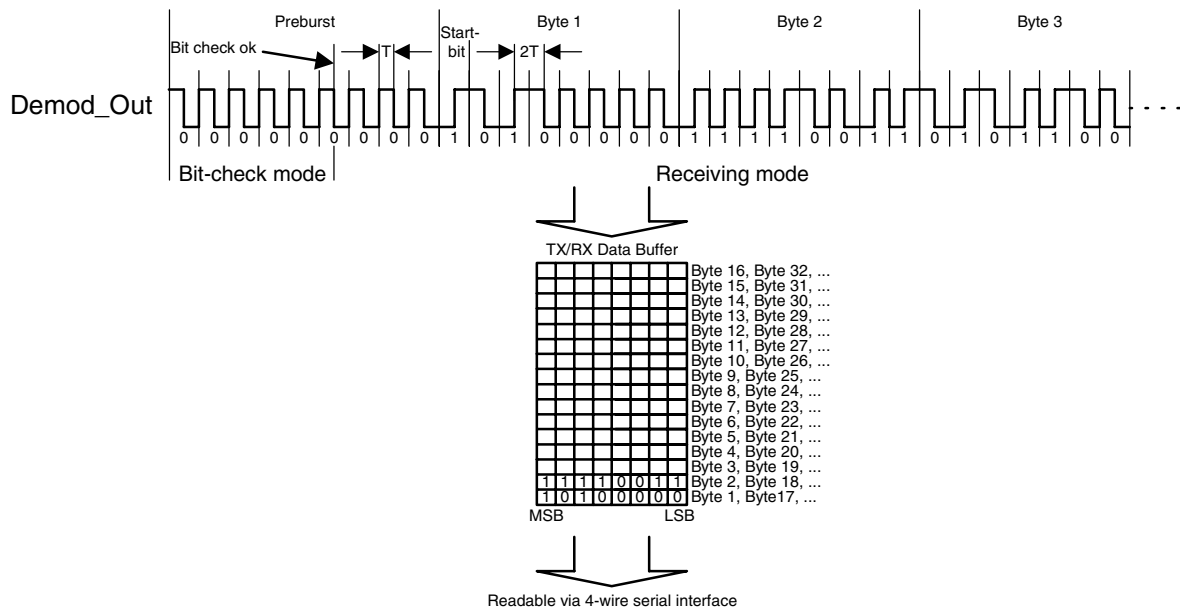


If the TX/RX data buffer control logic detects the start bit, the data stream is written in the TX/RX data buffer byte by byte. The start bit is part of the first data byte and must be different from the bits of the preburst. If the preburst consists of a sequence of '00000...', the start bit must be a 1. If the preburst consists of a sequence of '11111...', the start bit must be a 0.

If the data stream consists of more than 16 bytes, a buffer overflow occurs and the TX/RX data buffer control logic overwrites the bytes already stored in the TX/RX data buffer. So it is very important to ensure that the data is read in time so that no buffer overflow occurs in that case (see Figure 33 on page 45). There is a counter that indicates the number of received bytes in the TX/RX data buffer (see section "Transceiver Configuration"). If a byte is transferred to the microcontroller, the counter is decremented, if a byte is received, the counter is incremented. The counter value is available via the 4-wire serial interface.

An interrupt is issued, if the counter while counting forwards reaches the value defined by the control bits IR0 and IR1 in control register 1.

**Figure 48.** Receiving Mode (TMODE = 0)



If the TX/RX data buffer control logic detects a bit error, an interrupt is issued and the transceiver is set back to the start-up mode (see Figure 40 on page 50, Figure 41 on page 51 and Figure 49 on page 57).

Bit error: a)  $t_{ee} < T_{Lim\_min}$  or  $T_{Lim\_max} < t_{ee} < T_{Lim\_min\_2T}$  or  $t_{ee} > T_{Lim\_max\_2T}$

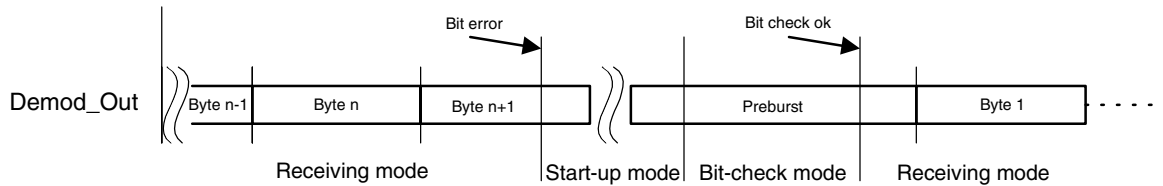
b) Logical error (no edge detected in the bit center)

Note: The byte consisting of the bit error will not be stored in the TX/RX data buffer. Thus it is not available via the 4-wire serial interface.

Writing the control register 1, 4, 5 or 6 during receiving mode resets the TX/RX data buffer control logic and the counter which indicates the number of received bytes. If the bits OPM0 and OPM1 are still '1' after writing to a control register, the transceiver changes to the start-up mode (start-up signal processing).



**Figure 49.** Bit Error (TMODE = 0)



**Table 38.** RX Modulation Scheme

Mode	ASK/_NFSK	T_MODE	RF <sub>IN</sub>	Bit in TX/RX Data Buffer	Level on Pin SD0_TMDO
RX	0	0	$f_{FSK\_L} \rightarrow f_{FSK\_H}$	1	Z
		0	$f_{FSK\_H} \rightarrow f_{FSK\_L}$	0	Z
		1	$f_{FSK\_H}$	-	1
		1	$f_{FSK\_L}$	-	0
	1	0	$f_{ASK\ off} \rightarrow f_{ASK\ on}$	1	Z
		0	$f_{ASK\ on} \rightarrow f_{ASK\ off}$	0	Z
		1	$f_{ASK\ on}$	-	1
		1	$f_{ASK\ off}$	-	0

**Recommended Lim<sub>min</sub> and Lim<sub>max</sub> for Maximum Sensitivity**

The sensitivity measurement in the section “Low-IF Receiver” in Table 3 on page 11 and Table 4 on page 11 have been done with the Lim<sub>min</sub> and Lim<sub>max</sub> values according to Table 39. These values are optimized for maximum sensitivity. Note that since these Limits are optimized for sensitivity the number of checked bit  $N_{Bit-check}$  has to be at least 6 to prevent the circuit from waking up to a often in polling mode due to noise.

**Table 39.** Recommended Lim<sub>min</sub> and Lim<sub>max</sub> Values for Different Baud Rates

$f_{RF} (f_{XTAL}) / MHz$	1.0 kBaud BR_Range_0/XLim = 1	2.4 kBaud BR_Range_0/XLim = 0	5 kBaud BR_Range_1/XLim = 0	10 Kbaud BR_Range_2/XLim = 0	20 kBaud BR_Range_3/XLim = 0
315.0 (12.73193)	Lim <sub>min</sub> = 13 (261 $\mu s$ ) Lim <sub>max</sub> = 38 (744 $\mu s$ )	Lim <sub>min</sub> = 12 (121 $\mu s$ ) Lim <sub>max</sub> = 34 (332 $\mu s$ )	Lim <sub>min</sub> = 11 (55 $\mu s$ ) Lim <sub>max</sub> = 32 (156 $\mu s$ )	Lim <sub>min</sub> = 11 (28 $\mu s$ ) Lim <sub>max</sub> = 32 (78 $\mu s$ )	Lim <sub>min</sub> = 11 (14 $\mu s$ ) Lim <sub>max</sub> = 31 (38 $\mu s$ )
433.92 (13.25311)	Lim <sub>min</sub> = 13 (251 $\mu s$ ) Lim <sub>max</sub> = 38 (715 $\mu s$ )	Lim <sub>min</sub> = 12 (116 $\mu s$ ) Lim <sub>max</sub> = 34 (319 $\mu s$ )	Lim <sub>min</sub> = 11 (53 $\mu s$ ) Lim <sub>max</sub> = 32 (150 $\mu s$ )	Lim <sub>min</sub> = 11 (27 $\mu s$ ) Lim <sub>max</sub> = 32 (75 $\mu s$ )	Lim <sub>min</sub> = 11 (13 $\mu s$ ) Lim <sub>max</sub> = 32 (37 $\mu s$ )
868.3 (13.41191)	Lim <sub>min</sub> = 13 (248 $\mu s$ ) Lim <sub>max</sub> = 38 (706 $\mu s$ )	Lim <sub>min</sub> = 12 (115 $\mu s$ ) Lim <sub>max</sub> = 34 (315 $\mu s$ )	Lim <sub>min</sub> = 11 (52 $\mu s$ ) Lim <sub>max</sub> = 32 (148 $\mu s$ )	Lim <sub>min</sub> = 11 (26 $\mu s$ ) Lim <sub>max</sub> = 32 (74 $\mu s$ )	Lim <sub>min</sub> = 11 (13 $\mu s$ ) Lim <sub>max</sub> = 32 (37 $\mu s$ )

## TX Operation

The transceiver is set to TX operation by using the bits OPM0 and OPM1 in the control register 1.

**Table 40.** Control Register 1

OPM1	OPM0	Function
0	1	TX mode

Before activating TX mode, the TX parameters (baud rate, modulation scheme ... ) must be selected as illustrated in Figure 50 on page 59. The baud rate depends on Baud 0 and Baud 1 in control register 6, Lim\_min0 to Lim\_min5 in control register 5 and XLIM in control register 4 (see section “Control Register”). The modulation is selected with ASK\_/NFSK in control register 4. The FSK frequency deviation is fixed to about  $\pm 16$  kHz. If P\_Mode is set to 1, the Manchester modulator is disabled and pattern mode is active (NRZ, see Table 41 on page 61).

After the transceiver is set to TX mode the start-up mode is active and the PLL is enabled. If the PLL is locked, the TX mode is active.

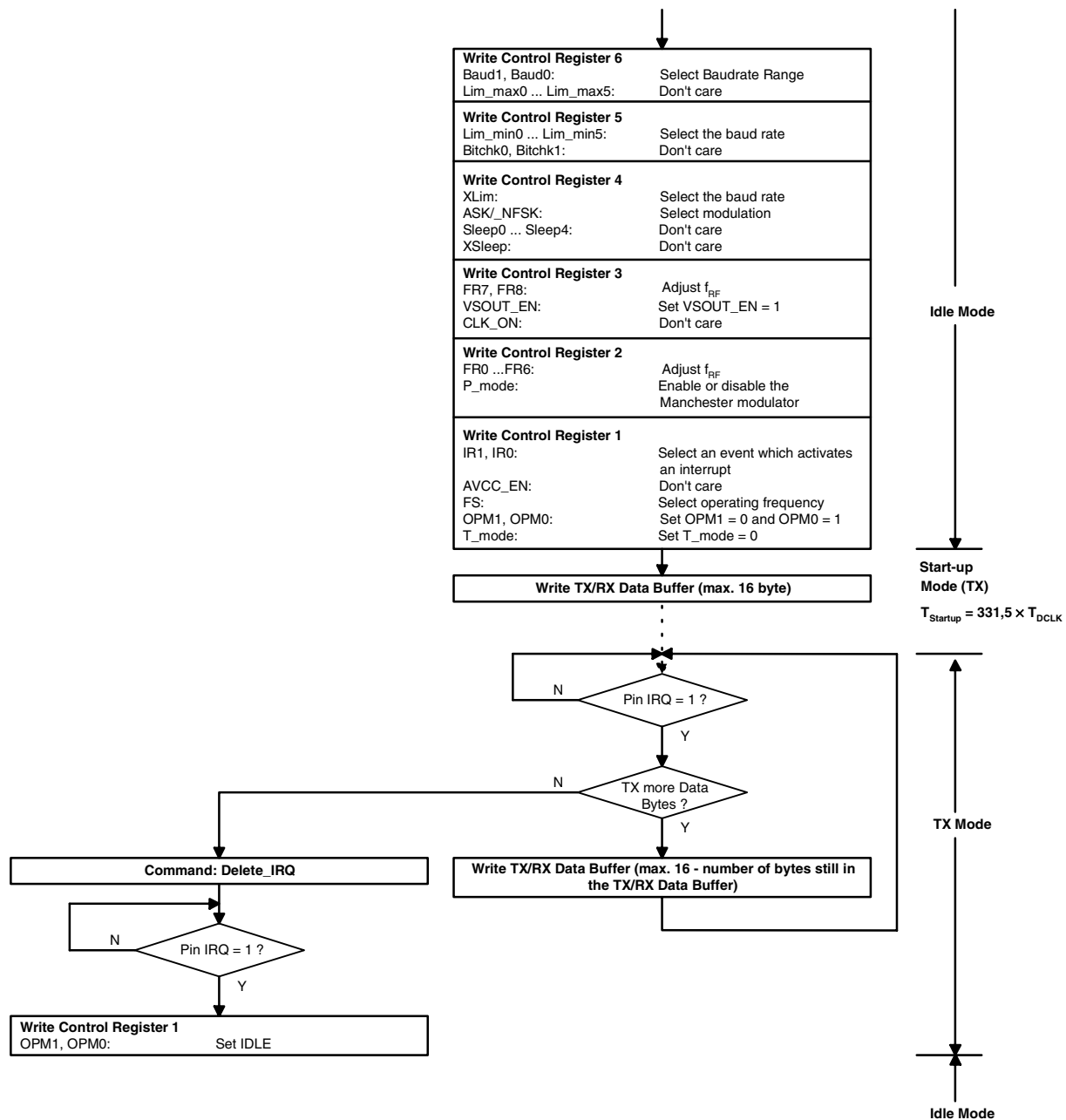
If the transceiver is in start-up or TX mode, the TX/RX data buffer can be loaded via the 4-wire serial interface. After the first byte is in the buffer and the TX mode is active, the transceiver starts transmitting automatically (beginning with the MSB). While transmitting it is permanently possible to load new data in the TX/RX data buffer. To prevent a buffer overflow or interruptions during transmitting the user must ensure that data is loaded at the same speed as it is transmitted.

There is a counter that indicates the number of bytes to be transmitted (see section “Transceiver Configuration”). If a byte is loaded, the counter is incremented, if a byte is transmitted, the counter is decremented. The counter value is available via the 4-wire serial interface. An IRQ is issued, if the counter while counting backwards reaches the value defined by the control bits IR0 and IR1 in control register 1.

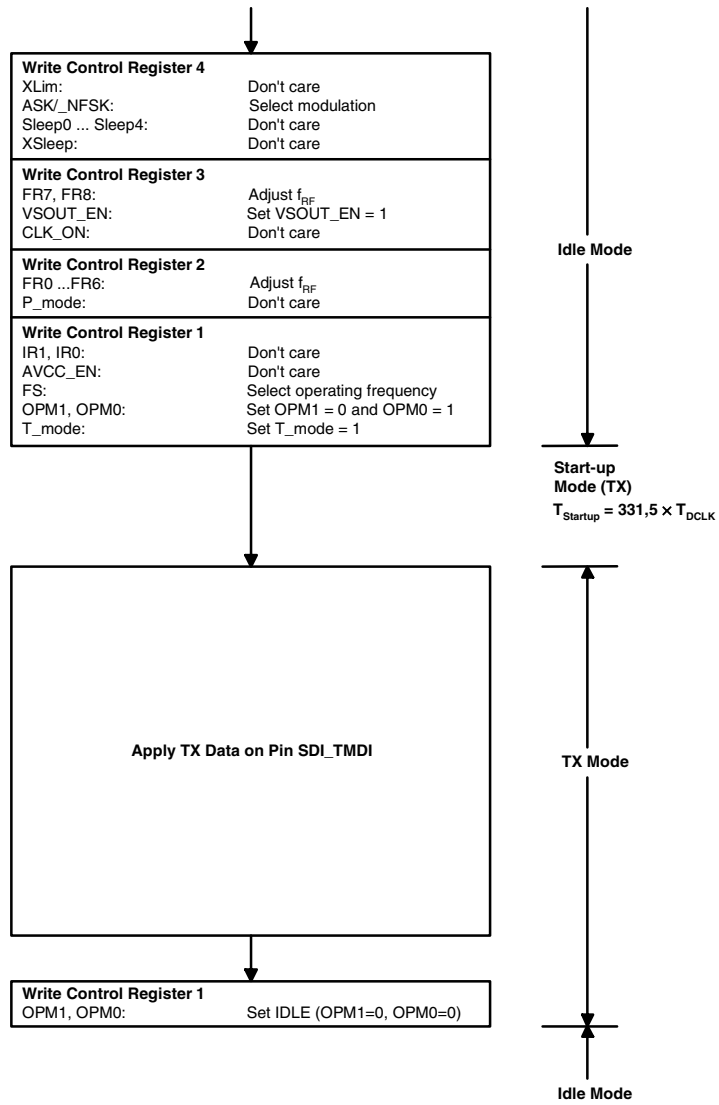
Note: Writing to the control register 1, 4, 5 or 6 during TX mode, resets the TX/RX data buffer and the counter which indicates the number of bytes to be transmitted.

If T\_Mode in control register 1 is set to 1, the transceiver is in TX transparent mode. In this mode the TX/RX data buffer is disabled and the TX data stream must be applied on pin SDI\_TMDI. Figure 50 on page 59 illustrates the flow chart of the TX transparent mode.

**Figure 50.** TX Operation (T\_MODE = 0)



**Figure 51. TX Transparent Mode (T\_MODE = 1)**



**Table 41. TX Modulation Schemes**

Mode	ASK/_NFSK	P_Mode	T_Mode	Bit in TX/RX Data Buffer	Level on Pin SDI_TMDI	RF <sub>OUT</sub>
TX	0	0	0	1	X	$f_{FSK\_L} \rightarrow f_{FSK\_H}$
		0	0	0	X	$f_{FSK\_H} \rightarrow f_{FSK\_L}$
		1	0	1	X	$f_{FSK\_H}$
		1	0	0	X	$f_{FSK\_L}$
		X	1	X	1	$f_{FSK\_H}$
		X	1	X	0	$f_{FSK\_L}$
	1	0	0	1	X	$f_{ASK} \text{ off} \rightarrow f_{ASK} \text{ on}$
		0	0	0	X	$f_{ASK} \text{ on} \rightarrow f_{ASK} \text{ off}$
		1	0	1	X	$f_{ASK} \text{ on}$
		1	0	0	X	$f_{ASK} \text{ off}$
		X	1	X	1	$f_{ASK} \text{ on}$
		X	1	X	0	$f_{ASK} \text{ off}$

## Interrupts

Via pin IRQ, the transceiver signals different operating conditions to a connected micro-controller. If a specific operating condition occurs, pin IRQ is set to high level.

If an interrupt occurs it is recommended to delete the interrupt be immediately deleted by reading the status register, thus the next possible interrupt doesn't get lost. If the Interrupt pin doesn't switch to low level by reading the status register the interrupt was triggered by the RX/TX data buffer. In this case read or write the RX/TX data buffer according to Table 42.

**Table 42. Interrupt Handling**

Operating Conditions Which Sets Pin IRQ to High Level	Operations Which Sets Pin IRQ to Low Level
<b>Events in Status Register</b>	
State transition of status bit STn (0 →1; 1 →0)	Read status register or Command Delete IRQ
Appearance of status bit Power_On (0 →1)	
Appearance of status bit P_On_Aux (0 →1)	
<b>Events During TX Operation (T_MODE = 0)</b>	
4, 8 or 12 Bytes are in the TX data buffer or the TX data buffer is empty (depends on IR0 and IR1 in control register 1).	Write TX data buffer or Write control register 1 or Write control register 4 or Write control register 5 or Write control register 6 or Command delete IRQ
<b>Events During RX Operation (T_MODE = 0)</b>	
4, 8 or 12 received bytes are in the RX data buffer or a receiving error is occurred (depends on IR0 and IR1 in control register 1).	Read RX data buffer or Write control register 1 or Write control register 4 or Write control register 5 or Write control register 6 or Command delete IRQ
Successful Bit-check (P_MODE = 0)	Command delete IRQ

## Absolute Maximum Ratings

Stresses beyond those listed under “Absolute Maximum Ratings” may cause permanent damage to the device. This is a stress rating only and functional operation of the device at these or any other conditions beyond those indicated in the operational sections of this specification is not implied. Exposure to absolute maximum rating conditions for extended periods may affect device reliability.

Parameters	Symbol	Min.	Max.	Unit
Junction temperature	$T_j$		150	°C
Storage temperature	$T_{stg}$	-55	+125	°C
Ambient temperature	$T_{amb}$	-40	+105	°C
Supply voltage VS2	$V_{MaxVS2}$	-0.3	+7.2	V
Supply voltage VS1	$V_{MaxVS1}$	-0.3	+4	V
Supply voltage VAUX	$V_{MaxVAUX}$	-0.3	+7.2	V
Supply voltage VSINT	$V_{MaxVSINT}$	-0.3	+5.5	V
ESD (Human Body Model ESD S 5.1) every pin	HBM	-2	+2	kV
ESD (Machine Model JEDEC A115A) every pin	MM	-200	+200	V
Maximum input level, input matched to 50 $\Omega$	$P_{in\_max}$		10	dBm

## Thermal Resistance

Parameters	Symbol	Value	Unit
Junction ambient	$R_{thJA}$	25	K/W

## Electrical Characteristics: General

All parameters refer to GND and are valid for  $T_{amb} = -40^{\circ}\text{C}$  to  $+105^{\circ}\text{C}$ ,  $V_{VS1} = V_{VS2} = 2.4\text{ V}$  to  $3.6\text{ V}$  (1-battery application),  $V_{VS2} = 4.4\text{ V}$  to  $6.6\text{ V}$  (2-battery application) and  $V_{VS2} = V_{VAUX} = 4.75\text{ V}$  to  $5.25\text{ V}$  (car application). Typical values are given at  $V_{VS1} = V_{VS2} = 3\text{ V}$  and  $T_{amb} = 25^{\circ}\text{C}$ ,  $f_{RF} = 433.92\text{ MHz}$  (1-battery application) unless otherwise specified. Details about current consumption, timing and digital pin properties can be found in the specific sections of the “Electrical Characteristics”.

No.	Parameters	Test Conditions	Pin <sup>(1)</sup>	Symbol	Min.	Typ.	Max.	Unit	Type*
<b>1</b>	<b>RX_TX_IDLE Mode</b>								
1.1	RF operating frequency range	ATA5811 $V_{433\_N868} = 0\text{ V}$	4, 10	$f_{RF}$	867		870	MHz	A
		ATA5811 $V_{433\_N868} = AVCC$	4, 10	$f_{RF}$	433		435	MHz	A
		ATA5812 $V_{433\_N868} = 0\text{ V}$	4, 10	$f_{RF}$	313		316	MHz	A
1.2	Supply current OFF mode	$V_{VS1} = V_{VS2} = 3\text{ V}$ , $V_{VSINT} = 0\text{ V}$ (1 battery) and $V_{VS2} = 6\text{ V}$ (2 battery) OFF mode is not available if $V_{VS2} = V_{VAUX} = 5\text{ V}$ $V_{VSINT} = 0\text{ V}$ (car)		$I_{S\_OFF}$		<10		nA	A
1.3	Supply current Idle mode	$V_{VSOUT}$ disabled, XTO running $V_{VS1} = V_{VS2} = 3\text{ V}$ (1 battery)		$I_{S\_IDLE}$		220		$\mu\text{A}$	B
		$V_{VS2} = 6\text{ V}$ (2 battery)		$I_{S\_IDLE}$		310		$\mu\text{A}$	B
		$V_{VS2} = V_{VAUX} = 5\text{ V}$ (car)		$I_{S\_IDLE}$		310		$\mu\text{A}$	B
1.4	System start-up time	From OFF mode to Idle mode including reset and XTO start-up (see Figure 30 on page 42) XTAL: $C_m = 5\text{ fF}$ , $C_0 = 1.8\text{ pF}$ , $R_m = 15\ \Omega$		$T_{PWR\_ON\_IRQ\_1}$		0.3		ms	C
1.5	RX start-up time	From Idle mode to receiving mode $N_{\text{Bit-check}} = 3$ Baud rate = 20 kBaud, BR_Range_3 (see Figure 40 on page 50, Figure 41 on page 51 and Figure 42 on page 52)		$T_{\text{Startup\_PLL}} + T_{\text{Startup\_Sig\_Proc}} + T_{\text{Bit-check}}$		1.39		ms	A
1.6	TX start-up time	From Idle mode to TX mode (see Figure 50 on page 59)		$T_{\text{Startup}}$		0.4		ms	A

\*) Type means: A = 100% tested, B = 100% correlation tested, C = Characterized on samples, D = Design parameter

Note: 1. Pin numbers in brackets mean they were measured with RF\_IN matched to  $50\ \Omega$  according to Figure 7 on page 10 with component values according to Table 2 on page 10 and RF\_OUT matched to  $50\ \Omega$  according to Figure 16 on page 19 with component values according to Table 7 on page 19.

## Electrical Characteristics: General (Continued)

All parameters refer to GND and are valid for  $T_{amb} = -40^{\circ}\text{C}$  to  $+105^{\circ}\text{C}$ ,  $V_{VS1} = V_{VS2} = 2.4\text{ V}$  to  $3.6\text{ V}$  (1-battery application),  $V_{VS2} = 4.4\text{ V}$  to  $6.6\text{ V}$  (2-battery application) and  $V_{VS2} = V_{VAUX} = 4.75\text{ V}$  to  $5.25\text{ V}$  (car application). Typical values are given at  $V_{VS1} = V_{VS2} = 3\text{ V}$  and  $T_{amb} = 25^{\circ}\text{C}$ ,  $f_{RF} = 433.92\text{ MHz}$  (1-battery application) unless otherwise specified. Details about current consumption, timing and digital pin properties can be found in the specific sections of the “Electrical Characteristics”.

No.	Parameters	Test Conditions	Pin <sup>(1)</sup>	Symbol	Min.	Typ.	Max.	Unit	Type*
<b>2</b>	<b>Receiver/RX Mode</b>								
2.1	Supply current RX mode	$f_{RF} = 433.92\text{ MHz}$ and $f_{RF} = 315\text{ MHz}$	17, 18	$I_{S\_RX}$		10.5		mA	A
		$f_{RF} = 868\text{ MHz}$	17, 18	$I_{S\_RX}$		10.3		mA	A
2.2	Supply current RX polling mode	$T_{Sleep} = 49.45\text{ ms}$ $X_{SLEEP} = 8$ , Sleep = 5 Baud rate = 20 kBaud FSK, $V_{VSOUT}$ disabled	17, 18	$I_P$		444		$\mu\text{A}$	B
2.3	Input sensitivity FSK $f_{RF} = 433.92\text{ MHz}$	FSK deviation $f_{DEV} = \pm 16\text{ kHz}$ limits according to Table 39 on page 57, BER = $10^{-3}$ $T_{amb} = 25^{\circ}\text{C}$							
		Baud rate 20 kBaud	(4)	$P_{REF\_FSK}$	-104.0	-106.0	-107.5	dBm	B
		Baud rate 2.4 kBaud	(4)	$P_{REF\_FSK}$	-107.5	-109.5	-111.0	dBm	B
2.4	Input sensitivity ASK $f_{RF} = 433.92\text{ MHz}$	ASK 100%, level of carrier limits according to Table 39 on page 57, BER = $10^{-3}$ $T_{amb} = 25^{\circ}\text{C}$							
		Baud rate 10 kBaud	(4)	$P_{REF\_ASK}$	-110.5	-112.5	-114.0	dBm	B
		Baud rate 2.4 kBaud	(4)	$P_{REF\_ASK}$	-114.5	-116.5	-118.0	dBm	B
2.5	Sensitivity change at $f_{RF} = 315.0\text{ MHz}$ $f_{RF} = 868.3\text{ MHz}$ compared to $f_{RF} = 433.92\text{ MHz}$	$f_{RF} = 433.92\text{ MHz}$ to $f_{RF} = 315.00\text{ MHz}$	(4)	$\Delta P_{REF1}$		-1.0		dB	B
		$f_{RF} = 433.92\text{ MHz}$ to $f_{RF} = 868.00\text{ MHz}$ $P = P_{REF\_ASK} + \Delta P_{REF1} +$ $\Delta P_{REF2}$ $P = P_{REF\_FSK} + \Delta P_{REF1} +$ $\Delta P_{REF2}$				+2.7			
2.6	Maximum frequency offset in FSK mode	Maximum frequency difference of $f_{RF}$ between receiver and transmitter in FSK mode ( $f_{RF}$ is the center frequency of the FSK signal with $f_{DEV} = \pm 16\text{ kHz}$ )	(4)	$\Delta f_{OFFSET}$	-58		+58	kHz	B

\*) Type means: A = 100% tested, B = 100% correlation tested, C = Characterized on samples, D = Design parameter

Note: 1. Pin numbers in brackets mean they were measured with RF\_IN matched to 50  $\Omega$  according to Figure 7 on page 10 with component values according to Table 2 on page 10 and RF\_OUT matched to 50  $\Omega$  according to Figure 16 on page 19 with component values according to Table 7 on page 19.



## Electrical Characteristics: General (Continued)

All parameters refer to GND and are valid for  $T_{amb} = -40^{\circ}\text{C}$  to  $+105^{\circ}\text{C}$ ,  $V_{VS1} = V_{VS2} = 2.4\text{ V}$  to  $3.6\text{ V}$  (1-battery application),  $V_{VS2} = 4.4\text{ V}$  to  $6.6\text{ V}$  (2-battery application) and  $V_{VS2} = V_{VAUX} = 4.75\text{ V}$  to  $5.25\text{ V}$  (car application). Typical values are given at  $V_{VS1} = V_{VS2} = 3\text{ V}$  and  $T_{amb} = 25^{\circ}\text{C}$ ,  $f_{RF} = 433.92\text{ MHz}$  (1-battery application) unless otherwise specified. Details about current consumption, timing and digital pin properties can be found in the specific sections of the “Electrical Characteristics”.

No.	Parameters	Test Conditions	Pin <sup>(1)</sup>	Symbol	Min.	Typ.	Max.	Unit	Type*
2.7	Sensitivity change versus temperature, supply voltage and frequency offset	FSK $f_{DEV} = \pm 16\text{ kHz}$ $\Delta f_{OFFSET} \leq \pm 58\text{ kHz}$ ASK 100% $\Delta f_{OFFSET} \leq 58\text{ kHz}$ $P = P_{REF\_ASK} + \Delta P_{REF1} + \Delta P_{REF2}$ $P = P_{REF\_FSK} + \Delta P_{REF1} + \Delta P_{REF2}$	(4)	$\Delta P_{REF2}$	+4.5		-1.5		B
2.8	Supported FSK frequency deviation	With up to 2 dB loss of sensitivity. Note that the tolerable frequency offset is for $f_{DEV} = \pm 22\text{ kHz}$ , 6 kHz lower than for $f_{DEV} = \pm 16\text{ kHz}$ hence $\Delta f_{OFFSET} \leq \pm 52\text{ kHz}$	(4)	$f_{DEV}$	$\pm 14$	$\pm 16$	$\pm 22$	kHz	B
2.9	System noise figure	$f_{RF} = 315\text{ MHz}$	(4)	NF		6.0		dB	B
		$f_{RF} = 433.92\text{ MHz}$	(4)	NF		7.0		dB	B
		$f_{RF} = 868.3\text{ MHz}$	(4)	NF		9.7		dB	B
2.10	Intermediate frequency	$f_{RF} = 868.3\text{ MHz}$		$f_{IF}$		226		kHz	A
		$f_{RF} = 433.92\text{ MHz}$		$f_{IF}$		223		kHz	A
		$f_{RF} = 315\text{ MHz}$		$f_{IF}$		227		kHz	A
2.11	System bandwidth	This value is for information only! Note that for crystal and system frequency offset calculations, $\Delta f_{OFFSET}$ must be used.	(4)	SBW		185		kHz	A
2.12	System outband 2nd-order input intercept point with respect to $f_{IF}$	$\Delta f_{meas1} = 1,800\text{ MHz}$ $\Delta f_{meas2} = 2,026\text{ MHz}$ $f_{IF} = \Delta f_{meas2} - \Delta f_{meas1}$	(4)	IIP2		+50		dBm	C
2.13	System outband 3rd-order input intercept point	$\Delta f_{meas1} = 1.8\text{ MHz}$ $\Delta f_{meas2} = 3.6\text{ MHz}$ $f_{RF} = 315\text{ MHz}$	(4)	IIP3		-22		dBm	C
		$f_{RF} = 433.92\text{ MHz}$	(4)	IIP3		-21		dBm	C
		$f_{RF} = 868.3\text{ MHz}$	(4)	IIP3		-17		dBm	C

\*) Type means: A = 100% tested, B = 100% correlation tested, C = Characterized on samples, D = Design parameter

Note: 1. Pin numbers in brackets mean they were measured with RF\_IN matched to  $50\ \Omega$  according to Figure 7 on page 10 with component values according to Table 2 on page 10 and RF\_OUT matched to  $50\ \Omega$  according to Figure 16 on page 19 with component values according to Table 7 on page 19.

## Electrical Characteristics: General (Continued)

All parameters refer to GND and are valid for  $T_{amb} = -40^{\circ}\text{C}$  to  $+105^{\circ}\text{C}$ ,  $V_{VS1} = V_{VS2} = 2.4\text{ V}$  to  $3.6\text{ V}$  (1-battery application),  $V_{VS2} = 4.4\text{ V}$  to  $6.6\text{ V}$  (2-battery application) and  $V_{VS2} = V_{VAUX} = 4.75\text{ V}$  to  $5.25\text{ V}$  (car application). Typical values are given at  $V_{VS1} = V_{VS2} = 3\text{ V}$  and  $T_{amb} = 25^{\circ}\text{C}$ ,  $f_{RF} = 433.92\text{ MHz}$  (1-battery application) unless otherwise specified. Details about current consumption, timing and digital pin properties can be found in the specific sections of the “Electrical Characteristics”.

No.	Parameters	Test Conditions	Pin <sup>(1)</sup>	Symbol	Min.	Typ.	Max.	Unit	Type*
2.14	System outband input 1 dB compression point	$\Delta f_{meas1} = 10\text{ MHz}$ $f_{RF} = 315\text{ MHz}$	(4)	I1dBCP		-31		dBm	C
		$f_{RF} = 433.92\text{ MHz}$	(4)	I1dBCP		-30		dBm	C
		$f_{RF} = 868.3\text{ MHz}$	(4)	I1dBCP		-27		dBm	C
2.15	LNA input impedance	$f_{RF} = 315\text{ MHz}$	4	$Z_{in\_LNA}$		(44 – j233)		$\Omega$	C
		$f_{RF} = 433.92\text{ MHz}$	4	$Z_{in\_LNA}$		(32 – j169)		$\Omega$	C
		$f_{RF} = 868.3\text{ MHz}$	4	$Z_{in\_LNA}$		(21 – j78)		$\Omega$	C
2.16	Maximum peak RF input level, ASK and FSK	BER < $10^{-3}$ , ASK: 100%	(4)	$P_{IN\_max}$	-10	+10		dBm	C
		FSK: $f_{DEV} = \pm 16\text{ kHz}$	(4)	$P_{IN\_max}$	-10	+10		dBm	C
2.17	LO spurious at LNA_IN	$f < 1\text{ GHz}$	(4)				-57	dBm	C
		$f > 1\text{ GHz}$	(4)				-47	dBm	C
		$f_{RF} = 315\text{ MHz}$	(4)			-100		dBm	C
		$f_{RF} = 433.92\text{ MHz}$	(4)			-97		dBm	C
		$f_{RF} = 868.3\text{ MHz}$	(4)			-84		dBm	C
2.18	Image rejection	Within the complete image band	(4)		20	30		dB	A
2.19	Useful signal to interferer ratio	Peak level of useful signal to peak level of interferer for BER < $10^{-3}$ with any modulation scheme of interferer							
		FSK BR_Ranges 0, 1, 2	(4)	$SNR_{FSK0-2}$		2	3	dB	B
		FSK BR_Range_3	(4)	$SNR_{FSK3}$		4	6	dB	B
		ASK ( $P_{RF} < P_{RFIN\_High}$ )	(4)	$SNR_{ASK}$		10	12	dB	B
2.20	RSSI output	Dynamic range	(4), 36	$D_{RSSI}$		70		dB	A
		Lower level of range $f_{RF} = 315\text{ MHz}$ $f_{RF} = 433.92\text{ MHz}$ $f_{RF} = 868.3\text{ MHz}$	(4), 36	$P_{RFIN\_Low}$		-116 -115 -112.3		dBm dBm dBm	A
		Upper level of range $f_{RF} = 315\text{ MHz}$ $f_{RF} = 433.92\text{ MHz}$ $f_{RF} = 868.3\text{ MHz}$	(4), 36	$P_{RFIN\_High}$		-46 -45 -42.3		dBm dBm dBm	A
		Gain	(4), 36		5.5	8.0	10.5	mV/dB	A
		Output voltage range	(4), 36	$OV_{RSSI}$	400		1100	mV	A
		2.21	Output resistance RSSI pin	RX mode TX mode	36	$R_{RSSI}$	8 32	10 40	12.5 50

\*) Type means: A = 100% tested, B = 100% correlation tested, C = Characterized on samples, D = Design parameter

Note: 1. Pin numbers in brackets mean they were measured with RF\_IN matched to 50  $\Omega$  according to Figure 7 on page 10 with component values according to Table 2 on page 10 and RF\_OUT matched to 50  $\Omega$  according to Figure 16 on page 19 with component values according to Table 7 on page 19.

## Electrical Characteristics: General (Continued)

All parameters refer to GND and are valid for  $T_{amb} = -40^{\circ}\text{C}$  to  $+105^{\circ}\text{C}$ ,  $V_{VS1} = V_{VS2} = 2.4\text{ V}$  to  $3.6\text{ V}$  (1-battery application),  $V_{VS2} = 4.4\text{ V}$  to  $6.6\text{ V}$  (2-battery application) and  $V_{VS2} = V_{VAUX} = 4.75\text{ V}$  to  $5.25\text{ V}$  (car application). Typical values are given at  $V_{VS1} = V_{VS2} = 3\text{ V}$  and  $T_{amb} = 25^{\circ}\text{C}$ ,  $f_{RF} = 433.92\text{ MHz}$  (1-battery application) unless otherwise specified. Details about current consumption, timing and digital pin properties can be found in the specific sections of the "Electrical Characteristics".

No.	Parameters	Test Conditions	Pin <sup>(1)</sup>	Symbol	Min.	Typ.	Max.	Unit	Type*
2.22	Blocking	Sensitivity (BER = $10^{-3}$ ) is reduced by 6 dB if a continuous wave blocking signal at $\pm\Delta f$ is $\Delta P_{Block}$ higher than the useful signal level (baud rate = 20 kBaud, FSK, $f_{DEV} \pm 16\text{kHz}$ , Manchester code)							
		$f_{RF} = 315\text{ MHz}$ $\Delta f \pm 0.75\text{ MHz}$ $\Delta f \pm 1.0\text{ MHz}$ $\Delta f \pm 1.5\text{ MHz}$ $\Delta f \pm 5\text{ MHz}$ $\Delta f \pm 10\text{ MHz}$	(4)	$\Delta P_{Block}$		56 60 63 69 71		dBC	C
		$f_{RF} = 433.92\text{ MHz}$ $\Delta f \pm 0.75\text{ MHz}$ $\Delta f \pm 1.0\text{ MHz}$ $\Delta f \pm 1.5\text{ MHz}$ $\Delta f \pm 5\text{ MHz}$ $\Delta f \pm 10\text{ MHz}$	(4)	$\Delta P_{Block}$		55 59 62 68 70		dBC	C
		$f_{RF} = 868.3\text{ MHz}$ $\Delta f \pm 0.75\text{ MHz}$ $\Delta f \pm 1.0\text{ MHz}$ $\Delta f \pm 1.5\text{ MHz}$ $\Delta f \pm 5\text{ MHz}$ $\Delta f \pm 10\text{ MHz}$	(4)	$\Delta P_{Block}$		50 53 57 67 69		dBC	C
2.23	CDEM	$C_6$ in Figure 4 on page 6, Figure 5 on page 7 and Figure 6 on page 8	37		-5%	15	+5%	nF	D
<b>3</b>	<b>Power Amplifier/TX Mode</b>								
3.1	Supply current TX mode power amplifier OFF	$f_{RF} = 868.3\text{ MHz}$		$I_{S\_TX\_PAOFF}$		6.50		mA	A
		$f_{RF} = 433.92\text{ MHz}$ and $f_{RF} = 315\text{ MHz}$		$I_{S\_TX\_PAOFF}$		6.95		mA	A

\*) Type means: A = 100% tested, B = 100% correlation tested, C = Characterized on samples, D = Design parameter

Note: 1. Pin numbers in brackets mean they were measured with RF\_IN matched to  $50\ \Omega$  according to Figure 7 on page 10 with component values according to Table 2 on page 10 and RF\_OUT matched to  $50\ \Omega$  according to Figure 16 on page 19 with component values according to Table 7 on page 19.

## Electrical Characteristics: General (Continued)

All parameters refer to GND and are valid for  $T_{amb} = -40^{\circ}\text{C}$  to  $+105^{\circ}\text{C}$ ,  $V_{VS1} = V_{VS2} = 2.4\text{ V}$  to  $3.6\text{ V}$  (1-battery application),  $V_{VS2} = 4.4\text{ V}$  to  $6.6\text{ V}$  (2-battery application) and  $V_{VS2} = V_{VAUX} = 4.75\text{ V}$  to  $5.25\text{ V}$  (car application). Typical values are given at  $V_{VS1} = V_{VS2} = 3\text{ V}$  and  $T_{amb} = 25^{\circ}\text{C}$ ,  $f_{RF} = 433.92\text{ MHz}$  (1-battery application) unless otherwise specified. Details about current consumption, timing and digital pin properties can be found in the specific sections of the “Electrical Characteristics”.

No.	Parameters	Test Conditions	Pin <sup>(1)</sup>	Symbol	Min.	Typ.	Max.	Unit	Type*
3.2	Output power 1	$V_{VS1} = V_{VS2} = 3\text{ V}$ $T_{amb} = 25^{\circ}\text{C}$ $V_{PWR\_H} = 0\text{ V}$  $f_{RF} = 315\text{ MHz}$ $R_{R\_PWR} = 56\text{ k}\Omega$ $R_{Lopt} = 2.5\text{ k}\Omega$  $f_{RF} = 433.92\text{ MHz}$ $R_{R\_PWR} = 56\text{ k}\Omega$ $R_{Lopt} = 2.3\text{ k}\Omega$  $f_{RF} = 868.3\text{ MHz}$ $R_{R\_PWR} = 30\text{ k}\Omega$ $R_{Lopt} = 1.3\text{ k}\Omega$  RF_OUT matched to $R_{Lopt} //$ $j/(2 \times \pi \times f_{RF} \times 1.0\text{ pF})$	(10)	$P_{REF1}$	-2.5	0	+2.5	dBm	B
3.3	Supply current TX mode power amplifier ON 1	PA on/0 dBm $f_{RF} = 315\text{ MHz}$	17, 18	$I_{S\_TX\_PAON1}$		8.5		mA	B
		$f_{RF} = 433.92\text{ MHz}$	17, 18	$I_{S\_TX\_PAON1}$		8.6		mA	B
		$f_{RF} = 868.3\text{ MHz}$	17, 18	$I_{S\_TX\_PAON1}$		9.6		mA	B
3.4	Output power 2	$V_{VS1} = V_{VS2} = 3\text{ V}$ $T_{amb} = 25^{\circ}\text{C}$ $V_{PWR\_H} = 0\text{ V}$  $f_{RF} = 315\text{ MHz}$ $R_{R\_PWR} = 30\text{ k}\Omega$ $R_{Lopt} = 1.0\text{ k}\Omega$  $f_{RF} = 433.92\text{ MHz}$ $R_{R\_PWR} = 27\text{ k}\Omega$ $R_{Lopt} = 1.1\text{ k}\Omega$  $f_{RF} = 868.3\text{ MHz}$ $R_{R\_PWR} = 16\text{ k}\Omega$ $R_{Lopt} = 0.5\text{ k}\Omega$  RF_OUT matched to $R_{Lopt} //$ $j/(2 \times \pi \times f_{RF} \times 1.0\text{ pF})$	(10)	$P_{REF2}$	3.5	5.0	6.5	dBm	B

\*) Type means: A = 100% tested, B = 100% correlation tested, C = Characterized on samples, D = Design parameter

Note: 1. Pin numbers in brackets mean they were measured with RF\_IN matched to  $50\ \Omega$  according to Figure 7 on page 10 with component values according to Table 2 on page 10 and RF\_OUT matched to  $50\ \Omega$  according to Figure 16 on page 19 with component values according to Table 7 on page 19.

## Electrical Characteristics: General (Continued)

All parameters refer to GND and are valid for  $T_{amb} = -40^{\circ}\text{C}$  to  $+105^{\circ}\text{C}$ ,  $V_{VS1} = V_{VS2} = 2.4\text{ V}$  to  $3.6\text{ V}$  (1-battery application),  $V_{VS2} = 4.4\text{ V}$  to  $6.6\text{ V}$  (2-battery application) and  $V_{VS2} = V_{VAUX} = 4.75\text{ V}$  to  $5.25\text{ V}$  (car application). Typical values are given at  $V_{VS1} = V_{VS2} = 3\text{ V}$  and  $T_{amb} = 25^{\circ}\text{C}$ ,  $f_{RF} = 433.92\text{ MHz}$  (1-battery application) unless otherwise specified. Details about current consumption, timing and digital pin properties can be found in the specific sections of the “Electrical Characteristics”.

No.	Parameters	Test Conditions	Pin <sup>(1)</sup>	Symbol	Min.	Typ.	Max.	Unit	Type*
3.5	Supply current TX mode power amplifier ON 2	PA on/5 dBm $f_{RF} = 315\text{ MHz}$	17, 18	$I_{S\_TX\_PAON2}$		10.3		mA	B
		$f_{RF} = 433.92\text{ MHz}$	17, 18	$I_{S\_TX\_PAON2}$		10.5		mA	B
		$f_{RF} = 868.3\text{ MHz}$	17, 18	$I_{S\_TX\_PAON2}$		11.2		mA	B
3.6	Output power 3	$V_{VS1} = V_{VS2} = 3\text{ V}$ $T_{amb} = 25^{\circ}\text{C}$ $V_{PWR\_H} = AVCC$  $f_{RF} = 315\text{ MHz}$ $R_{R\_PWR} = 30\text{ k}\Omega$ $R_{Lopt} = 0.38\text{ k}\Omega$  $f_{RF} = 433.92\text{ MHz}$ $R_{R\_PWR} = 27\text{ k}\Omega$ $R_{Lopt} = 0.36\text{ k}\Omega$  $f_{RF} = 868.3\text{ MHz}$ $R_{R\_PWR} = 20\text{ k}\Omega$ $R_{Lopt} = 0.22\text{ k}\Omega$  RF_OUT matched to $R_{Lopt} //$ $j/(2 \times \pi \times f_{RF} \times 1.0\text{ pF})$	(10)	$P_{REF3}$	8.5	10	11.5	dBm	B
3.7	Supply current TX mode power amplifier ON 3	PA on/10dBm $f_{RF} = 315\text{ MHz}$	17, 18	$I_{S\_TX\_PAON3}$		15.7		mA	B
		$f_{RF} = 433.92\text{ MHz}$	17, 18	$I_{S\_TX\_PAON3}$		15.8		mA	B
		$f_{RF} = 868.3\text{ MHz}$	17, 18	$I_{S\_TX\_PAON3}$		17.3		mA	B
3.8	Output power variation for full temperature and supply voltage range	$T_{amb} = -40^{\circ}\text{C}$ to $+105^{\circ}\text{C}$ $P_{out} = P_{REFX} + \Delta P_{REFX}$ $X = 1, 2$ or $3$ $V_{VS1} = V_{VS2} = 3.0\text{ V}$	(10)	$\Delta P_{REF}$		-0.8	-1.5	dB	B
		$V_{VS1} = V_{VS2} = 2.4\text{ V}$	(10)	$\Delta P_{REF}$			-3.5	dB	B
		$V_{VS1} = V_{VS2} = 2.7\text{ V}$	(10)	$\Delta P_{REF}$				-2.5	dB

\*) Type means: A = 100% tested, B = 100% correlation tested, C = Characterized on samples, D = Design parameter

Note: 1. Pin numbers in brackets mean they were measured with RF\_IN matched to  $50\ \Omega$  according to Figure 7 on page 10 with component values according to Table 2 on page 10 and RF\_OUT matched to  $50\ \Omega$  according to Figure 16 on page 19 with component values according to Table 7 on page 19.

## Electrical Characteristics: General (Continued)

All parameters refer to GND and are valid for  $T_{amb} = -40^{\circ}\text{C}$  to  $+105^{\circ}\text{C}$ ,  $V_{VS1} = V_{VS2} = 2.4\text{ V}$  to  $3.6\text{ V}$  (1-battery application),  $V_{VS2} = 4.4\text{ V}$  to  $6.6\text{ V}$  (2-battery application) and  $V_{VS2} = V_{VAUX} = 4.75\text{ V}$  to  $5.25\text{ V}$  (car application). Typical values are given at  $V_{VS1} = V_{VS2} = 3\text{ V}$  and  $T_{amb} = 25^{\circ}\text{C}$ ,  $f_{RF} = 433.92\text{ MHz}$  (1-battery application) unless otherwise specified. Details about current consumption, timing and digital pin properties can be found in the specific sections of the “Electrical Characteristics”.

No.	Parameters	Test Conditions	Pin <sup>(1)</sup>	Symbol	Min.	Typ.	Max.	Unit	Type*
3.9	Impedance RF_OUT in RX mode	$f_{RF} = 315\text{ MHz}$	10	$Z_{RF\_OUT\_RX}$		(36 -j502)		$\Omega$	C
		$f_{RF} = 433.92\text{ MHz}$	10	$Z_{RF\_OUT\_RX}$		(19 -j366)		$\Omega$	C
		$f_{RF} = 868.3\text{ MHz}$	10	$Z_{RF\_OUT\_RX}$		(2.8 -j141)		$\Omega$	C
3.10	Noise floor power amplifier	at $\pm 10\text{ MHz}$ /at 5 dBm $f_{RF} = 868.3\text{ MHz}$	(10)	$L_{TX10M}$		-125		dBc/Hz	C
		at $f_{RF} = 433.92\text{ MHz}$	(10)	$L_{TX10M}$		-126		dBc/Hz	C
		$f_{RF} = 315\text{ MHz}$	(10)	$L_{TX10M}$		-127		dBc/Hz	C
3.11	ASK modulation rate	This correspond to 10 kBaud Manchester coding and 20 kBaud NRZ coding		$f_{Data\_ASK}$			10	kHz	C
<b>4</b>	<b>XTO</b>								
4.1	Pulling XTO due to XTO, $C_{L1}$ and $C_{L2}$ tolerances	Pulling at nominal temperature and supply voltage $f_{XTAL} =$ resonant frequency of the XTAL $C_0 \geq 1.5\text{ pF}$ $R_m \leq 120\ \Omega$ $C_m \leq 7.0\text{ fF}$ $C_m \leq 14\text{ fF}$	24, 25	$\Delta f_{XTO1}$	-50 -100	$f_{XTAL}$	+50 +100	ppm	A
4.2	Transconductance XTO at start	At start-up, after start-up the amplitude is regulated to $V_{PPXTAL}$	24, 25	$g_{m, XTO}$		19		ms	B
4.3	XTO start-up time	$C_0 \leq 2.2\text{ pF}$ $C_m = 4.0\text{ fF}$ to $7.0\text{ fF}$ $R_m \leq 20\ \Omega$	24, 25	$T_{PWR\_ON\_IRQ\_1}$		300	800	$\mu\text{s}$	A
4.4	Maximum $C_0$ of XTAL	Required for stable operation with internal load capacitors	24, 25	$C_{0max}$			3.8	pF	D
4.5	Internal capacitors	$C_{L1}$ and $C_{L2}$	24, 25	$C_{L1}, C_{L2}$	14.8	18 pF	21.2	pF	B
4.6	Pulling of radio frequency $f_{RF}$ due to XTO, $C_{L1}$ and $C_{L2}$ versus temperature and supply changes	$1.5\text{ pF} \leq C_0 \leq 2.2\text{ pF}$ $C_m = 4.0\text{ fF}$ to $7.0\text{ fF}$ $R_m \leq 20\ \Omega$ PLL adjusted with FREQ at nominal temperature and supply voltage	4, 10	$\Delta f_{XTO2}$	-2		+2	ppm	C

\*) Type means: A = 100% tested, B = 100% correlation tested, C = Characterized on samples, D = Design parameter

Note: 1. Pin numbers in brackets mean they were measured with RF\_IN matched to  $50\ \Omega$  according to Figure 7 on page 10 with component values according to Table 2 on page 10 and RF\_OUT matched to  $50\ \Omega$  according to Figure 16 on page 19 with component values according to Table 7 on page 19.

## Electrical Characteristics: General (Continued)

All parameters refer to GND and are valid for  $T_{amb} = -40^{\circ}\text{C}$  to  $+105^{\circ}\text{C}$ ,  $V_{VS1} = V_{VS2} = 2.4\text{ V}$  to  $3.6\text{ V}$  (1-battery application),  $V_{VS2} = 4.4\text{ V}$  to  $6.6\text{ V}$  (2-battery application) and  $V_{VS2} = V_{VAUX} = 4.75\text{ V}$  to  $5.25\text{ V}$  (car application). Typical values are given at  $V_{VS1} = V_{VS2} = 3\text{ V}$  and  $T_{amb} = 25^{\circ}\text{C}$ ,  $f_{RF} = 433.92\text{ MHz}$  (1-battery application) unless otherwise specified. Details about current consumption, timing and digital pin properties can be found in the specific sections of the “Electrical Characteristics”.

No.	Parameters	Test Conditions	Pin <sup>(1)</sup>	Symbol	Min.	Typ.	Max.	Unit	Type*
4.7	Amplitude XTAL after start-up	$C_m = 5\text{ fF}$ , $C_0 = 1.8\text{ pF}$ $R_m = 15\ \Omega$							
		V(XTAL1, XTAL2) peak-to-peak value	24, 25	$V_{PPXTAL}$		700		mVpp	C
		V(XTAL1) peak-to-peak value	24, 25	$V_{PPXTAL}$		350		mVpp	C
4.8	Maximum series resistance $R_m$ of XTAL at start-up	$C_0 \leq 2.2\text{ pF}$ , start-up may take longer under these conditions	24, 25	$Z_{XTAL12\_START}$	-1,500	-2,000		$\Omega$	B
4.9	Maximum series resistance $R_m$ of XTAL after start-up	$C_0 \leq 2.2\text{ pF}$ $C_m = 4.0\text{ fF}$ to $7.0\text{ fF}$ $R_m \leq 20\ \Omega$	24, 25	$R_{m\_max}$		15	120	$\Omega$	B
4.10	Nominal XTAL load resonant frequency	FREQ = 3,928 $f_{RF} = 868.3\text{ MHz}$ $f_{RF} = 433.92\text{ MHz}$ $f_{RF} = 315\text{ MHz}$	24, 25	$f_{XTAL}$		13.41191 13.25311 12.73193		MHz MHz	D
4.11	External CLK frequency	FREQ = 3,928	30	$f_{CLK}$	$f_{CLK} = \frac{f_{XTO}}{3}$			MHz	D
		$f_{RF} = 868.3\text{ MHz}$ CLK division ratio = 3 CLK has nominal 50% duty cycle	30	$f_{CLK}$		4.471		MHz	D
		$f_{RF} = 433.92\text{ MHz}$ CLK division ratio = 3 CLK has nominal 50% duty cycle	30	$f_{CLK}$		4.41 8		MHz	D
		$f_{RF} = 315\text{ MHz}$ CLK division ratio = 3 CLK has nominal 50% duty cycle	30	$f_{CLK}$		4.244		MHz	D
4.12	DC voltage after start-up	$V_{DC}(XTAL1, XTAL2)$ XTO running (Idle mode, RX mode and TX mode)	24, 25	$V_{DCXTO}$	-150	-30		mV	

\*) Type means: A = 100% tested, B = 100% correlation tested, C = Characterized on samples, D = Design parameter

Note: 1. Pin numbers in brackets mean they were measured with RF\_IN matched to  $50\ \Omega$  according to Figure 7 on page 10 with component values according to Table 2 on page 10 and RF\_OUT matched to  $50\ \Omega$  according to Figure 16 on page 19 with component values according to Table 7 on page 19.

## Electrical Characteristics: General (Continued)

All parameters refer to GND and are valid for  $T_{amb} = -40^{\circ}\text{C}$  to  $+105^{\circ}\text{C}$ ,  $V_{VS1} = V_{VS2} = 2.4\text{ V}$  to  $3.6\text{ V}$  (1-battery application),  $V_{VS2} = 4.4\text{ V}$  to  $6.6\text{ V}$  (2-battery application) and  $V_{VS2} = V_{VAUX} = 4.75\text{ V}$  to  $5.25\text{ V}$  (car application). Typical values are given at  $V_{VS1} = V_{VS2} = 3\text{ V}$  and  $T_{amb} = 25^{\circ}\text{C}$ ,  $f_{RF} = 433.92\text{ MHz}$  (1-battery application) unless otherwise specified. Details about current consumption, timing and digital pin properties can be found in the specific sections of the “Electrical Characteristics”.

No.	Parameters	Test Conditions	Pin <sup>(1)</sup>	Symbol	Min.	Typ.	Max.	Unit	Type*
<b>5</b>	<b>Synthesizer</b>								
5.1	Spurious TX mode	At $\pm f_{CLK}$ , CLK enabled $f_{RF} = 315\text{ MHz}$ $f_{RF} = 433.92\text{ MHz}$ $f_{RF} = 868.3\text{ MHz}$		$SP_{TX}$		-72 -68 -70		dBC	A
		at $\pm f_{XTO}$ $f_{RF} = 315\text{ MHz}$ $f_{RF} = 433.92\text{ MHz}$ $f_{RF} = 868.3\text{ MHz}$		$SP_{TX}$		-70 -66 -60		dBC	A
5.2	Spurious RX mode	At $\pm f_{CLK}$ , CLK enabled $f_{RF} = 315\text{ MHz}$ $f_{RF} = 433.92\text{ MHz}$ $f_{RF} = 868.3\text{ MHz}$		$SP_{RX}$		< -75 < -75 < -75		dBC	A
		at $\pm f_{XTO}$ $f_{RF} = 315\text{ MHz}$ $f_{RF} = 433.92\text{ MHz}$ $f_{RF} = 868.3\text{ MHz}$		$SP_{RX}$		-75 -75 -68		dBC	A
5.3	In loop phase noise TX mode	Measured at 20 kHz distance to carrier $f_{RF} = 315\text{ MHz}$ $f_{RF} = 433.92\text{ MHz}$ $f_{RF} = 868.3\text{ MHz}$		$L_{TX20k}$		-85 -80 -75		dBC/Hz	A
5.4	Phase noise at 1M RX mode	$f_{RF} = 315\text{ MHz}$ $f_{RF} = 433.92\text{ MHz}$ $f_{RF} = 868.3\text{ MHz}$		$L_{RX1M}$		-121 -120 -113		dBC/Hz	A
5.5	Phase noise at 1M TX mode	$f_{RF} = 315\text{ MHz}$ $f_{RF} = 433.92\text{ MHz}$ $f_{RF} = 868.3\text{ MHz}$		$L_{TX1M}$		-113 -111 -107		dBC/Hz	A
5.6	Phase noise at 10M RX mode	Noise floor PLL		$L_{RX10M}$		-135		dBC/Hz	B
5.7	Loop bandwidth PLL TX mode	Frequency where the absolute value loop gain is equal to 1		$f_{Loop\_PLL}$		70		kHz	B
5.8	Frequency deviation TX mode	$f_{RF} = 315\text{ MHz}$ $f_{RF} = 433.92\text{ MHz}$ $f_{RF} = 868.3\text{ MHz}$		$f_{DEV\_TX}$		$\pm 15.54$ $\pm 16.17$ $\pm 16.37$		kHz	D
5.9	Frequency resolution	$f_{RF} = 315\text{ MHz}$ $f_{RF} = 433.92\text{ MHz}$ $f_{RF} = 868.3\text{ MHz}$	4, 10	$\Delta f_{Step\_PLL}$		777.1 808.9 818.6		Hz	D

\*) Type means: A = 100% tested, B = 100% correlation tested, C = Characterized on samples, D = Design parameter

Note: 1. Pin numbers in brackets mean they were measured with RF\_IN matched to 50  $\Omega$  according to Figure 7 on page 10 with component values according to Table 2 on page 10 and RF\_OUT matched to 50  $\Omega$  according to Figure 16 on page 19 with component values according to Table 7 on page 19.



## Electrical Characteristics: General (Continued)

All parameters refer to GND and are valid for  $T_{amb} = -40^{\circ}\text{C}$  to  $+105^{\circ}\text{C}$ ,  $V_{VS1} = V_{VS2} = 2.4\text{ V}$  to  $3.6\text{ V}$  (1-battery application),  $V_{VS2} = 4.4\text{ V}$  to  $6.6\text{ V}$  (2-battery application) and  $V_{VS2} = V_{VAUX} = 4.75\text{ V}$  to  $5.25\text{ V}$  (car application). Typical values are given at  $V_{VS1} = V_{VS2} = 3\text{ V}$  and  $T_{amb} = 25^{\circ}\text{C}$ ,  $f_{RF} = 433.92\text{ MHz}$  (1-battery application) unless otherwise specified. Details about current consumption, timing and digital pin properties can be found in the specific sections of the “Electrical Characteristics”.

No.	Parameters	Test Conditions	Pin <sup>(1)</sup>	Symbol	Min.	Typ.	Max.	Unit	Type*
5.10	FSK modulation rate	This correspond to 20 kBaud Manchester coding and 40 kBaud NRZ coding		$f_{Data\_FSK}$			20	kHz	B
<b>6</b>	<b>RX/TX Switch</b>								
6.1	Impedance RX mode	RX mode, pin 38 with short connection to GND, $f_{RF} = 0\text{ Hz (DC)}$	39	$Z_{Switch\_RX}$		23000		$\Omega$	A
		$f_{RF} = 315\text{ MHz}$	39	$Z_{Switch\_RX}$		(11.3 - j214)		$\Omega$	C
		$f_{RF} = 433.92\text{ MHz}$	39	$Z_{Switch\_RX}$		(10.3 - j153)		$\Omega$	C
		$f_{RF} = 868.3\text{ MHz}$	39	$Z_{Switch\_RX}$		(8.9 - j73)		$\Omega$	C
6.2	Impedance TX mode	TX mode, pin 38 with short connection to GND, $f_{RF} = 0\text{ Hz (DC)}$	39	$Z_{Switch\_TX}$		5		$\Omega$	A
		$f_{RF} = 315\text{ MHz}$	39	$Z_{Switch\_TX}$		(4.8 + j3.2)		$\Omega$	C
		$f_{RF} = 433.92\text{ MHz}$			(4.5 + j4.3)	C			
		$f_{RF} = 868.3\text{ MHz}$			(5 + j9)	C			
<b>7</b>	<b>Microcontroller Interface</b>								
7.1	Voltage range for microcontroller interface	$I_{VSINT} < 10\text{ }\mu\text{A}$ if CLK is disabled and all interface pins are in stable condition and unloaded	27, 28, 29, 30, 31, 32, 33, 34, 35		2.4		5.25	V	A
7.2	CLK output rise and fall time	$f_{CLK} < 4.5\text{ MHz}$ $C_L = 10\text{ pF}$ $C_L = \text{Load capacitance on pin CLK}$ $2.4\text{ V} \leq V_{VSINT} \leq 5.25\text{ V}$ 20% to 80% $V_{VSINT}$	30	$t_{rise}$  $t_{fall}$		20	30	ns	B
						20	30	ns	

\*) Type means: A = 100% tested, B = 100% correlation tested, C = Characterized on samples, D = Design parameter

Note: 1. Pin numbers in brackets mean they were measured with RF\_IN matched to  $50\text{ }\Omega$  according to Figure 7 on page 10 with component values according to Table 2 on page 10 and RF\_OUT matched to  $50\text{ }\Omega$  according to Figure 16 on page 19 with component values according to Table 7 on page 19.

## Electrical Characteristics: General (Continued)

All parameters refer to GND and are valid for  $T_{amb} = -40^{\circ}\text{C}$  to  $+105^{\circ}\text{C}$ ,  $V_{VS1} = V_{VS2} = 2.4\text{ V}$  to  $3.6\text{ V}$  (1-battery application),  $V_{VS2} = 4.4\text{ V}$  to  $6.6\text{ V}$  (2-battery application) and  $V_{VS2} = V_{VAUX} = 4.75\text{ V}$  to  $5.25\text{ V}$  (car application). Typical values are given at  $V_{VS1} = V_{VS2} = 3\text{ V}$  and  $T_{amb} = 25^{\circ}\text{C}$ ,  $f_{RF} = 433.92\text{ MHz}$  (1-battery application) unless otherwise specified. Details about current consumption, timing and digital pin properties can be found in the specific sections of the “Electrical Characteristics”.

No.	Parameters	Test Conditions	Pin <sup>(1)</sup>	Symbol	Min.	Typ.	Max.	Unit	Type*
7.4	Current consumption of the microcontroller interface	CLK enabled $V_{VSOUT}$ enabled  CLK disabled $V_{VSOUT}$ enabled  $V_{VSOUT}$ disabled  $C_L$ = Load capacitance on pin CLK (All interface pins, except pin CLK, are in stable condition and unloaded)	27	$I_{VSINT}$		$I_{VSINT} = \frac{(C_{CLK} + C_L) \times V_{VSINT} \times f_{XTO}}{3}$ $< 10\ \mu\text{A}$  $< 10\ \mu\text{A}$			
7.5	Internal equivalent capacitance	Used for current calculation	30, 27	CCLK		8		pF	B
<b>8 Power Supply General Definitions and AUX Mode</b>									
8.1	Current consumption of an external device connected to pin VSOUT			$I_{EXT}$		$I_{EXT} = I_{VSOUT} - I_{VSINT}$  $I_{EXT} = I_{VSOUT}$			
8.2	AUX mode								

\*) Type means: A = 100% tested, B = 100% correlation tested, C = Characterized on samples, D = Design parameter

Note: 1. Pin numbers in brackets mean they were measured with RF\_IN matched to  $50\ \Omega$  according to Figure 7 on page 10 with component values according to Table 2 on page 10 and RF\_OUT matched to  $50\ \Omega$  according to Figure 16 on page 19 with component values according to Table 7 on page 19.



## Electrical Characteristic: 1-Battery Application (Continued)

All parameters refer to GND and are valid for  $T_{amb} = -40^{\circ}\text{C}$  to  $+105^{\circ}\text{C}$ ,  $V_{VS1} = V_{VS2} = 2.4\text{ V}$  to  $3.6\text{ V}$  typical values at  $V_{VS1} = V_{VS2} = 3\text{ V}$  and  $T_{amb} = 25^{\circ}\text{C}$ . Application according to Figure 4 on page 6.  $f_{RF} = 315.0\text{ MHz}/433.92\text{ MHz}/868.3\text{ MHz}$  unless otherwise specified

No.	Parameters	Test Conditions	Pin	Symbol	Min.	Typ.	Max.	Unit	Type*
9.3	Power supply output voltage	1-battery application $V_{VS1} = V_{VS2} \geq 2.6\text{ V}$ VAUX open <sup>(1)</sup> $I_{VSOUT} \leq 13.5\text{ mA}$ (no voltage regulator to stabilize $V_{VSOUT}$ )  $V_{VS1} = V_{VS2} \geq 2.425\text{ V}$ VAUX open <sup>(1)</sup> $I_{VSOUT} \leq 1.5\text{ mA}$ (no voltage regulator to stabilize $V_{VSOUT}$ )	22	$V_{VSOUT}$	2.4		$V_{VS1}$	V	B
9.4	Supply voltage for microcontroller interface		27	$V_{VSINT}$	2.4		5.25	V	A
9.5	Threshold hysteresis	$V_{Thres\_2} - V_{Thres\_1}$	22	$\Delta V_{Thres}$	60	80	100	mV	B
9.6	Reset threshold voltage at pin VSOUT (N_RESET)		22	$V_{Thres\_1}$	2.18	2.3	2.42	V	A
9.7	Reset threshold voltage at pin VSOUT (Low_Batt)		22	$V_{Thres\_2}$	2.26	2.38	2.5	V	A
9.8	Supply current OFF mode	$V_{VS1} = V_{VS2} \leq 3.6\text{ V}$ $V_{VSINT} = 0\text{ V}$	17, 18, 22, 27	$I_{S\_OFF}$		2	350	nA	A
9.9	Current in Idle mode on pin VS1 and VS2	$V_{VS1} = V_{VS2} \leq 3\text{ V}$ $I_{VSOUT} = 0$  CLK enabled $V_{VSOUT}$ enabled  CLK disabled $V_{VSOUT}$ enabled  $V_{VSOUT}$ disabled	17, 18	$I_{IDLE\_VS1, 2}$		312	430	$\mu\text{A}$	A
						260	370	$\mu\text{A}$	B
						225	320	$\mu\text{A}$	B
9.10	Supply current Idle mode		17, 18, 22, 27	$I_{S\_IDLE}$	$I_{S\_IDLE} = I_{IDLE\_VS1, 2} + I_{VSINT} + I_{EXT}$				
9.11	Current in RX mode on pin VS1 and VS2	$V_{VS1} = V_{VS2} \leq 3\text{ V}$ $I_{VSOUT} = 0$	17, 18	$I_{RX\_VS1, 2}$		10.5	14	mA	A
9.12	Supply current RX mode	CLK enabled $V_{VSOUT}$ enabled	17, 18, 22, 27	$I_{S\_RX}$	$I_{S\_RX} = I_{RX\_VS1, 2} + I_{VSINT} + I_{EXT}$				

\*) Type means: A = 100% tested, B = 100% correlation tested, C = Characterized on samples, D = Design parameter

Note: 1. The voltage of VAUX may rise up to 2 V. The current  $I_{VAUX}$  may not exceed 100  $\mu\text{A}$ .

## Electrical Characteristic: 1-Battery Application (Continued)

All parameters refer to GND and are valid for  $T_{amb} = -40^{\circ}\text{C}$  to  $+105^{\circ}\text{C}$ ,  $V_{VS1} = V_{VS2} = 2.4\text{ V}$  to  $3.6\text{ V}$  typical values at  $V_{VS1} = V_{VS2} = 3\text{ V}$  and  $T_{amb} = 25^{\circ}\text{C}$ . Application according to Figure 4 on page 6.  $f_{RF} = 315.0\text{ MHz}/433.92\text{ MHz}/868.3\text{ MHz}$  unless otherwise specified

No.	Parameters	Test Conditions	Pin	Symbol	Min.	Typ.	Max.	Unit	Type*
9.13	Current during $T_{Startup\_PLL}$ on pin VS1 and VS2	$V_{VS1} = V_{VS2} \leq 3\text{ V}$ $I_{VSOUT} = 0$	17, 18	$I_{Startup\_PLL\_VS1,2}$		8.8	11.5	mA	C
9.14	Current in RX polling mode on pin VS1 and VS2	$I_P = \frac{I_{IDLE\_VS1,2} \times T_{SLEEP} + I_{Startup\_PLL\_VS1,2} \times T_{Startup\_PLL} + I_{RX\_VS1,2} \times (T_{Startup\_Sig\_Proc} + T_{Bitcheck})}{T_{Sleep} + T_{Startup\_PLL} + T_{Startup\_Sig\_Proc} + T_{Bitcheck}}$							
9.15	Supply current RX polling mode	CLK enabled $V_{VSOUT}$ enabled  CLK disabled $V_{VSOUT}$ enabled  $V_{VSOUT}$ disabled	17, 18, 22, 27	$I_{S\_Poll}$	$I_{S\_Poll} = I_P + I_{VSINT} + I_{EXT}$ $I_{S\_Poll} = I_P + I_{EXT}$ $I_{S\_Poll} = I_P$				
9.16	Current in TX mode on pin VS1 and VS2	$V_{VS1} = V_{VS2} \leq 3\text{ V}$ $I_{VSOUT} = 0$ $P_{out} = 5\text{ dBm}/10\text{ dBm}$ 315 MHz/5 dBm 315 MHz/10 dBm 433.92 MHz/5 dBm 433.92 MHz/10 dBm 868.3 MHz/5 dBm 868.3 MHz/10 dBm	17, 18	$I_{TX\_VS1\_VS2}$		10.3 15.7 10.5 15.8 11.2 17.3	13.4 20.5 13.5 20.5 14.5 22.5	mA	B
9.17	Supply current TX mode	CLK enabled $V_{VSOUT}$ enabled CLK disabled $V_{VSOUT}$ enabled	17, 18, 22, 27	$I_{S\_TX}$	$I_{S\_TX} = I_{TX\_VS1,2} + I_{VSINT} + I_{EXT}$ $I_{S\_TX} = I_{TX\_VS1,2} + I_{EXT}$				

\*) Type means: A = 100% tested, B = 100% correlation tested, C = Characterized on samples, D = Design parameter

Note: 1. The voltage of VAUX may rise up to 2 V. The current  $I_{VAUX}$  may not exceed 100  $\mu\text{A}$ .



## Electrical Characteristics: 2-Battery Application (Continued)

All parameters refer to GND and are valid for  $T_{amb} = -40\text{ }^{\circ}\text{C}$  to  $+105\text{ }^{\circ}\text{C}$ ,  $V_{VS2} = 4.4\text{ V}$  to  $6.6\text{ V}$  typical values at  $V_{VS2} = 6\text{ V}$  and  $T_{amb} = 25\text{ }^{\circ}\text{C}$ . Application according to Figure 6 on page 8.  $f_{RF} = 315.0\text{ MHz}/433.92\text{ MHz}/868.3\text{ MHz}$  unless otherwise specified

No.	Parameters	Test Conditions	Pin	Symbol	Min.	Typ.	Max.	Unit	Type*
10.11	Supply current RX mode	CLK enabled $V_{VSOUT}$ enabled	17, 22, 27	$I_{S\_RX}$	$I_{S\_RX} = I_{RX\_VS2} + I_{VSINT} + I_{EXT}$				
10.12	Current during $T_{Startup\_PLL}$ on pin VS2	$I_{VSOUT} = 0$	17	$I_{Startup\_PLL\_VS2}$		9.1	12	mA	C
10.13	Current in RX polling mode on on pin VS2	$I_P = \frac{I_{IDLE\_VS2} \times T_{SLEEP} + I_{Startup\_PLL\_VS2} \times T_{Startup\_PLL} + I_{RX\_VS2} \times (T_{Startup\_Sig\_Proc} + T_{Bitcheck})}{T_{Sleep} + T_{Startup\_PLL} + T_{Startup\_Sig\_Proc} + T_{Bitcheck}}$							
10.14	Supply current RX polling mode	CLK enabled $V_{VSOUT}$ enabled	17, 22, 27	$I_{S\_Poll}$	$I_{S\_Poll} = I_P + I_{VSINT} + I_{EXT}$				
		CLK disabled $V_{VSOUT}$ enabled			$I_{S\_Poll} = I_P + I_{EXT}$				
		$V_{VSOUT}$ disabled			$I_{S\_Poll} = I_P$				
10.15	Current in TX mode on pin VS2	$I_{VSOUT} = 0$	17, 19	$I_{TX\_VS2}$		10.7	13.9	mA	B
		$P_{out} = 5\text{ dBm}/10\text{ dBm}$				16.2	21.0		
		315 MHz/5 dBm				10.9	14.0		
		315 MHz/10 dBm				16.3	21.0		
		433.92 MHz/5 dBm				11.6	15.0		
		433.92 MHz/10 dBm				17.8	23.0		
10.16	Supply current TX mode	CLK enabled $V_{VSOUT}$ enabled	17, 22, 27	$I_{S\_TX}$	$I_{S\_TX} = I_{TX\_VS2} + I_{VSINT} + I_{EXT}$				
		CLK disabled			$I_{S\_TX} = I_{TX\_VS2} + I_{EXT}$				
		$V_{VSOUT}$ enabled							

\*) Type means: A = 100% tested, B = 100% correlation tested, C = Characterized on samples, D = Design parameter

Note: 1. The voltage of VAUX may rise up to 2 V. The current  $I_{VAUX}$  may not exceed 100  $\mu\text{A}$ .





## Electrical Characteristics: Car Application (Continued)

All parameters refer to GND and are valid for  $T_{amb} = -40^{\circ}\text{C}$  to  $+105^{\circ}\text{C}$ ,  $V_{VS2} = 4.75\text{ V}$  to  $5.25\text{ V}$ . Typical values at  $V_{VS2} = 5\text{ V}$  and  $T_{amb} = 25^{\circ}\text{C}$ . Application according to Figure 5 on page 7.  $f_{RF} = 315.0\text{ MHz}/433.92\text{ MHz}/868.3\text{ MHz}$  unless otherwise specified

No.	Parameters	Test Conditions	Pin	Symbol	Min.	Typ.	Max.	Unit	Type*
11.11	Current during $T_{Startup\_PLL}$ on pin VS2 and VAUX	$I_{VSOUT} = 0$	17, 19	$I_{Startup\_PLL\_VS2\_VAUX}$		9.1	12	mA	C
11.12	Current in RX_Polling_Mode on pin VS2 and VAUX $I_P = \frac{I_{IDLE\_VS2,VAUX} \times T_{SLEEP} + I_{Startup\_PLL\_VS2,VAUX} \times T_{Startup\_PLL} + I_{RX\_VS2,VAUX} \times (T_{Startup\_Sig\_Proc} + T_{Bitcheck})}{T_{Sleep} + T_{Startup\_PLL} + T_{Startup\_Sig\_Proc} + T_{Bitcheck}}$								
11.13	Supply current in RX polling mode	CLK enabled $V_{VSOUT}$ enabled  CLK disabled $V_{VSOUT}$ enabled  $V_{VSOUT}$ disabled	17, 19, 22, 27	$I_{S\_Poll}$		$I_{S\_Poll} = I_P + I_{VSINT} + I_{EXT}$ $I_{S\_Poll} = I_P + I_{EXT}$ $I_{S\_Poll} = I_P$			
11.14	Current in TX mode on pin VS2 and VAUX	$I_{VSOUT} = 0$ $P_{out} = 5\text{dBm}/10\text{dBm}$ 315 MHz/5dBm 315 MHz/10dBm 433.92 MHz/5dBm 433.92 MHz/10dBm 868.3 MHz/10dBm	17, 19	$I_{TX\_VS2\_VAUX}$		10.7 16.2 10.9 16.3 11.6 17.8	13.9 21.0 14.0 21.0 15.0 23.0	mA	B
11.15	Supply current in TX mode	CLK enabled $V_{VSOUT}$ enabled CLK disabled $V_{VSOUT}$ enabled	17, 19, 22, 27	$I_{S\_TX}$		$I_{S\_TX} = I_{TX\_VS2\_VAUX} + I_{VSINT} + I_{EXT}$ $I_{S\_TX} = I_{TX\_VS2\_VAUX} + I_{EXT}$			

\*) Type means: A = 100% tested, B = 100% correlation tested, C = Characterized on samples, D = Design parameter

## Digital Timing Characteristics

All parameters refer to GND and are valid for  $T_{amb} = -40^{\circ}\text{C}$  to  $+105^{\circ}\text{C}$ .  $V_{VS1} = V_{S2} = 2.4\text{ V}$  to  $3.6\text{ V}$  (1-battery application),  $V_{VS2} = 4.4\text{ V}$  to  $6.6\text{ V}$  (2-battery application) and  $V_{VS2} = 4.75\text{ V}$  to  $5.25\text{ V}$  (car application), typical values at  $V_{VS1} = V_{VS2} = 3\text{ V}$  and  $T_{amb} = 25^{\circ}\text{C}$  unless otherwise specified.

No.	Parameters	Test Conditions	Pin	Symbol	Min.	Typ.	Max.	Unit	Type*
<b>12</b>	<b>Basic Clock Cycle of the Digital Circuitry</b>								
12.1	Basic clock cycle			$T_{DCLK}$	$16/f_{XTO}$		$16/f_{XTO}$	$\mu\text{s}$	A
12.2	Extended basic clock cycle	XLIM = 0  BR_Range_0 BR_Range_1 BR_Range_2 BR_Range_3  XLIM = 1  BR_Range_0 BR_Range_1 BR_Range_2 BR_Range_3		$T_{XDCLK}$	8 4 2 1 $\times T_{DCLK}$		8 4 2 1 $\times T_{DCLK}$	$\mu\text{s}$	A
<b>13</b>	<b>RX Mode/RX Polling Mode</b>								
13.1	Sleep time	Sleep and XSleep are defined in control register 4		$T_{Sleep}$	$Sleep \times$ $X_{Sleep} \times$ $1024 \times$ $T_{DCLK}$		$Sleep \times$ $X_{Sleep} \times$ $1024 \times$ $T_{DCLK}$	ms	A
13.2	Start-up PLL RX mode	from Idle mode		$T_{Startup\_PLL}$		$798.5 \times$ $T_{DCLK}$	$798.5 \times$ $T_{DCLK}$	$\mu\text{s}$	A
13.3	Start-up signal processing	BR_Range_0 BR_Range_1 BR_Range_2 BR_Range_3		$T_{Startup\_Sig\_Proc}$	882 498 306 210 $\times T_{DCLK}$		882 498 306 210 $\times T_{DCLK}$		A
13.4	Time for Bit-check	Average time during polling. No RF signal applied. $f_{Signal} = 1/(2 \times t_{ee})$ Signal data rate Manchester (Lim_min and Lim_max up to $\pm 50\%$ of $t_{ee}$ , see Figure 43 on page 52) Bit-check time for a valid input signal $f_{Sig}$  $N_{Bit-check} = 0$ $N_{Bit-check} = 3$ $N_{Bit-check} = 6$ $N_{Bit-check} = 9$		$T_{Bit\_check}$		$1/f_{Signal}$		ms	C

\*) Type means: A = 100% tested, B = 100% correlation tested, C = Characterized on samples, D = Design parameter

## Digital Timing Characteristics (Continued)

All parameters refer to GND and are valid for  $T_{amb} = -40^{\circ}\text{C}$  to  $+105^{\circ}\text{C}$ .  $V_{VS1} = V_{S2} = 2.4\text{ V}$  to  $3.6\text{ V}$  (1-battery application),  $V_{VS2} = 4.4\text{ V}$  to  $6.6\text{ V}$  (2-battery application) and  $V_{VS2} = 4.75\text{ V}$  to  $5.25\text{ V}$  (car application), typical values at  $V_{VS1} = V_{VS2} = 3\text{ V}$  and  $T_{amb} = 25^{\circ}\text{C}$  unless otherwise specified.

No.	Parameters	Test Conditions	Pin	Symbol	Min.	Typ.	Max.	Unit	Type*
13.5	Baud-rate range	BR_Range = BR_Range0 BR_Range1 BR_Range2 BR_Range3		BR_Range	1.0 2.0 4.0 8.0		2.5 5.0 10.0 20.0	kBaud	A
13.6	Minimum time period between edges at pin SDO_TMDO in RX transparent mode	XLIM = 0  BR_Range_0 BR_Range_1 BR_Range_2 BR_Range_3  XLIM = 1  BR_Range_0 BR_Range_1 BR_Range_2 BR_Range_3	31	$T_{DATA\_min}$	$10 \times T_{XDCLK}$			$\mu\text{s}$	A
13.7	Edge-to-edge time period of the data signal for full sensitivity in RX mode	BR_Range_0 BR_Range_1 BR_Range_2 BR_Range_3		$T_{DATA}$	200 100 50 25		500 250 125 62.5	$\mu\text{s}$	B
<b>14</b>	<b>TX Mode</b>								
14.1	Start-up time	From Idle mode		$T_{Startup}$		$331.5 \times T_{DCLK}$	$331.5 \times T_{DCLK}$	$\mu\text{s}$	A
<b>15</b>	<b>Configuration of the Transceiver with 4-wire Serial Interface</b>								
15.1	CS set-up time to rising edge of SCK		33, 35	$T_{CS\_setup}$	$1.5 \times T_{DCLK}$			$\mu\text{s}$	A
15.2	SCK cycle time		33	$T_{Cycle}$	2			$\mu\text{s}$	A
15.3	SDI_TMDI set-up time to rising edge of SCK		32, 33	$T_{Setup}$	250			ns	C
15.4	SDI_TMDI hold time from rising edge of SCK		32, 33	$T_{Hold}$	250			ns	C
15.5	SDO_TMDO enable time from rising edge of CS		31, 35	$T_{Out\_enable}$			250	ns	C
15.6	SDO_TMDO output delay from falling edge of SCK	$C_L = 10\text{ pF}$	31, 35	$T_{Out\_delay}$			250	ns	C
15.7	SDO_TMDO disable time from falling edge of CS		31, 33	$T_{Out\_disable}$			250	ns	C
15.8	CS disable time period		35	$T_{CS\_disable}$	$1.5 \times T_{DCLK}$			$\mu\text{s}$	A

\*) Type means: A = 100% tested, B = 100% correlation tested, C = Characterized on samples, D = Design parameter

## Digital Timing Characteristics (Continued)

All parameters refer to GND and are valid for  $T_{amb} = -40^{\circ}\text{C}$  to  $+105^{\circ}\text{C}$ .  $V_{VS1} = V_{S2} = 2.4\text{ V}$  to  $3.6\text{ V}$  (1-battery application),  $V_{VS2} = 4.4\text{ V}$  to  $6.6\text{ V}$  (2-battery application) and  $V_{VS2} = 4.75\text{ V}$  to  $5.25\text{ V}$  (car application), typical values at  $V_{VS1} = V_{VS2} = 3\text{ V}$  and  $T_{amb} = 25^{\circ}\text{C}$  unless otherwise specified.

No.	Parameters	Test Conditions	Pin	Symbol	Min.	Typ.	Max.	Unit	Type*	
15.9	Time period SCK low to CS high		33, 35	$T_{SCK\_setup1}$	250			ns	C	
15.10	Time period SCK low to CS low		33, 35	$T_{SCK\_setup2}$	250			ns	C	
15.11	Time period CS low to SCK high		33, 35	$T_{SCK\_hold}$	250			ns	C	
<b>16</b>	<b>Start Time Push Button <math>T_n</math> and PWR_ON</b>									
	Timing of wake-up via PWR_ON or $T_n$									
16.1	PWR_ON high to positive edge on pin IRQ (see Figure 30 on page 42)	From OFF mode to Idle mode, applications according to Figure 4 on page 6, Figure 5 on page 7 and Figure 6 on page 8 XTAL: $C_m = 4..7\text{ fF}$ (typ. 5 fF) $C_0 < 2.2\text{ pF}$ (typ. 1.8 pF) $R_m \leq 120\ \Omega$ (typ. 15 $\Omega$ )  1-battery application $C_1 = C_2 = 68\text{ nF}$ $C_3 = C_4 = 68\text{ nF}$ $C_5 = 10\text{ nF}$  2-battery application $C_1 = C_4 = 68\text{ nF}$ $C_2 = C_3 = 2.2\ \mu\text{F}$ $C_5 = 10\text{ nF}$  Car application $C_1 = C_3 = C_4 = 68\text{ nF}$ $C_2 = C_{12} = 2.2\ \mu\text{F}$ $C_5 = 10\text{ nF}$	29, 40	$T_{PWR\_ON\_IRQ\_1}$			0.3  0.45  0.45	0.8  1.3  1.3	ms	B

\*) Type means: A = 100% tested, B = 100% correlation tested, C = Characterized on samples, D = Design parameter

## Digital Timing Characteristics (Continued)

All parameters refer to GND and are valid for  $T_{amb} = -40^{\circ}\text{C}$  to  $+105^{\circ}\text{C}$ .  $V_{VS1} = V_{VS2} = 2.4\text{ V}$  to  $3.6\text{ V}$  (1-battery application),  $V_{VS2} = 4.4\text{ V}$  to  $6.6\text{ V}$  (2-battery application) and  $V_{VS2} = 4.75\text{ V}$  to  $5.25\text{ V}$  (car application), typical values at  $V_{VS1} = V_{VS2} = 3\text{ V}$  and  $T_{amb} = 25^{\circ}\text{C}$  unless otherwise specified.

No.	Parameters	Test Conditions	Pin	Symbol	Min.	Typ.	Max.	Unit	Type*
16.2	PWR_ON high to positive edge on pin IRQ (see Figure 30 on page 42)	Every mode except OFF mode	29, 40	$T_{PWR\_ON\_IRQ\_2}$			$2 \times T_{DCLK}$	$\mu\text{s}$	A
16.3	$T_n$ low to positive edge on pin IRQ (see Figure 28 on page 40)	From OFF mode to Idle mode, applications according to Figure 4 on page 6, Figure 5 on page 7 and Figure 6 on page 8 XTAL: $C_m = 4..7\text{ fF}$ (typ 5 fF) $C_0 < 2.2\text{ pF}$ (typ 1.8 pF) $R_m \leq 20\ \Omega$ (typ 15 $\Omega$ )  1-battery application $C_1 = C_2 = 68\text{ nF}$ $C_3 = C_4 = 68\text{ nF}$ $C_5 = 10\text{ nF}$  2-battery application $C_1 = C_4 = 68\text{ nF}$ $C_2 = C_3 = 2.2\ \mu\text{F}$ $C_5 = 10\text{ nF}$  Car application $C_1 = C_3 = C_4 = 68\text{ nF}$ $C_2 = C_{12} = 2.2\ \mu\text{F}$ $C_5 = 10\text{ nF}$	29, 41, 42, 43, 44, 45	$T_{Tn\_IRQ}$		0.3  0.45  0.45	0.8  1.3  1.3	ms	B
16.4	Push button debounce time	Every mode except OFF mode	29, 41, 42, 43, 44, 45	$T_{Debounce}$	8195 $\times T_{DCLK}$		8195 $\times T_{DCLK}$	$\mu\text{s}$	A

\*) Type means: A = 100% tested, B = 100% correlation tested, C = Characterized on samples, D = Design parameter

## Digital Port Characteristics

All parameter refer to GND and valid for  $T_{amb} = -40\text{ °C}$  to  $+105\text{ °C}$ ,  $V_{VS1} = V_{S2} = 2.4\text{ V}$  to  $3.6\text{ V}$  (1 Battery Application) and  $V_{VS2} = 4.4\text{ V}$  to  $6.6\text{ V}$  (2 Battery Application) and  $V_{VS2} = 4.75\text{ V}$  to  $5.25\text{ V}$  (Car Application) typical values at  $V_{VS1} = V_{VS2} = 3\text{ V}$  and  $T_{amb} = 25\text{ °C}$  unless otherwise specified

No.	Parameters	Test Conditions	Pin	Symbol	Min.	Typ.	Max.	Unit	Type*
<b>17</b>	<b>Digital Ports</b>								
17.1	CS input -Low level input voltage	$V_{VSINT} = 2.4\text{ V}$ to $5.25\text{ V}$	35	$V_{ll}$			$0.2 \times V_{VSINT}$	V	A
	-High level input voltage	$V_{VSINT} = 2.4\text{ V}$ to $5.25\text{ V}$	35	$V_{lh}$	$0.8 \times V_{VSINT}$		$V_{VSINT}$	V	A
17.2	SCK input -Low level input voltage	$V_{VSINT} = 2.4\text{ V}$ to $5.25\text{ V}$	33	$V_{ll}$			$0.2 \times V_{VSINT}$	V	A
	-High level input voltage	$V_{VSINT} = 2.4\text{ V}$ to $5.25\text{ V}$	33	$V_{lh}$	$0.8 \times V_{VSINT}$		$V_{VSINT}$	V	A
17.3	SDI_TMDI input -Low level input voltage	$V_{VSINT} = 2.4\text{ V}$ to $5.25\text{ V}$	32	$V_{ll}$			$0.2 \times V_{VSINT}$	V	A
	-High level input voltage	$V_{VSINT} = 2.4\text{ V}$ to $5.25\text{ V}$	32	$V_{lh}$	$0.8 \times V_{VSINT}$		$V_{VSINT}$	V	A
17.4	TEST1 input	TEST1 input must always be directly connected to GND	20						D
17.5	TEST2 input	TEST2 input must always be direct connected to GND	23						D
17.6	PWR_ON input -Low level input voltage	Internal pull-down with series connection of $40\text{ k}\Omega \pm 20\%$ resistor and diode	40	$V_{ll}$			0.4	V	A
	-High level input voltage <sup>(1)</sup>	Internal pull-down with series connection of $40\text{ k}\Omega \pm 20\%$ resistor and diode	40	$V_{lh}$	$0.8 \times V_{VS2}$			V	A
17.7	Tn input -Low level input voltage	Internal pull-up resistor of $50\text{ k}\Omega \pm 20\%$	41, 42, 43, 44, 45	$V_{ll}$			$0.2 \times V_{VS2}$	V	A
	-High level input voltage <sup>(1)</sup>	Internal pull-up resistor of $50\text{ k}\Omega \pm 20\%$	41, 42, 43, 44, 45	$V_{lh}$	$\times V_{VS2} - 0.5\text{ V}$			V	A
17.8	433_N868 input -Low level input voltage		6	$V_{ll}$			0.25	V	A
	-Input current low		6	$I_{ll}$			-5	$\mu\text{A}$	A
	-High level input voltage		6	$V_{lh}$	1.7		AVCC	V	A
	-Input current high		6	$I_{lh}$			1	$\mu\text{A}$	A

\*) Type means: A = 100% tested, B = 100% correlation tested, C = Characterized on samples, D = Design parameter

Note: 1. If a logic high level is applied to this pin a minimum serial impedance of  $100\ \Omega$  must be ensured for proper operation over full temperature range.

## Digital Port Characteristics (Continued)

All parameter refer to GND and valid for  $T_{amb} = -40\text{ }^{\circ}\text{C}$  to  $+105\text{ }^{\circ}\text{C}$ ,  $V_{VS1} = V_{S2} = 2.4\text{ V}$  to  $3.6\text{ V}$  (1 Battery Application) and  $V_{VS2} = 4.4\text{ V}$  to  $6.6\text{ V}$  (2 Battery Application) and  $V_{VS2} = 4.75\text{ V}$  to  $5.25\text{ V}$  (Car Application) typical values at  $V_{VS1} = V_{VS2} = 3\text{ V}$  and  $T_{amb} = 25\text{ }^{\circ}\text{C}$  unless otherwise specified

No.	Parameters	Test Conditions	Pin	Symbol	Min.	Typ.	Max.	Unit	Type*
17.9	PWR_H input -Low level input voltage		9	$V_{ll}$			0.25	V	A
	-Input current low		9	$I_{ll}$			-5	$\mu\text{A}$	A
	-High level input voltage		9	$V_{lh}$	1.7		AVCC	V	A
	-Input current high		9	$I_{lh}$			1	$\mu\text{A}$	A
17.10	SDO_TMDO output -Saturation voltage low	$V_{VSINT} = 2.4\text{ V}$ to $5.25\text{ V}$ $I_{SDO\_TMDO} = 250\text{ }\mu\text{A}$	31	$V_{ol}$		0.15	0.4	V	B
	Saturation voltage high	$V_{VSINT} = 2.4\text{ V}$ to $5.25\text{ V}$ $I_{SDO\_TMDO} = -250\text{ }\mu\text{A}$	31	$V_{oh}$	$V_{VSINT} - 0.4$	$V_{VSINT} - 0.15$		V	B
17.11	IRQ output -Saturation voltage low	$V_{VSINT} = 2.4\text{ V}$ to $5.25\text{ V}$ $I_{IRQ} = 250\text{ }\mu\text{A}$	29	$V_{ol}$		0.15	0.4	V	B
	Saturation voltage high	$V_{VSINT} = 2.4\text{ V}$ to $5.25\text{ V}$ $I_{IRQ} = -250\text{ }\mu\text{A}$	29	$V_{oh}$	$V_{VSINT} - 0.4$	$V_{VSINT} - 0.15$		V	B
17.12	CLK output -Saturation voltage low	$V_{VSINT} = 2.4\text{ V}$ to $5.25\text{ V}$ $I_{CLK} = 100\text{ }\mu\text{A}$ internal series resistor of $1\text{ k}\Omega$ for spurious reduction in PLL	30	$V_{ol}$		0.15	0.4	V	B
	Saturation voltage high	$V_{VSINT} = 2.4\text{ V}$ to $5.25\text{ V}$ $I_{CLK} = -100\text{ }\mu\text{A}$ internal series resistor of $1\text{ k}\Omega$ for spurious reduction in PLL	30	$V_{oh}$	$V_{VSINT} - 0.4$	$V_{VSINT} - 0.15$		V	B
17.13	N_RESET output -Saturation voltage low	$V_{VSINT} = 2.4\text{ V}$ to $5.25\text{ V}$ $I_{N\_RESET} = 250\text{ }\mu\text{A}$	28	$V_{ol}$		0.15	0.4	V	B
	-Saturation voltage high	$V_{VSINT} = 2.4\text{ V}$ to $5.25\text{ V}$ $I_{N\_RESET} = -250\text{ }\mu\text{A}$	28	$V_{oh}$	$V_{VSINT} - 0.4$	$V_{VSINT} - 0.15$		V	B
17.14	RX_ACTIVE output -Saturation voltage high	$V_{VSINT} = 2.4\text{ V}$ to $5.25\text{ V}$ $I_{RX\_ACTIVE} = -1.5\text{ mA}$	46	$V_{oh}$	$V_{AVCC} - 0.5\text{ V}$	$V_{AVCC} - 0.15\text{ V}$		V	B
	-Saturation voltage low	$V_{VSINT} = 2.4\text{ V}$ to $5.25\text{ V}$ $I_{RX\_ACTIVE} = 25\text{ }\mu\text{A}$	46	$V_{ol}$		0.25	0.4	V	B
17.15	DEM_OUT output Saturation voltage low	Open drain output $I_{DEM\_OUT} = 250\text{ }\mu\text{A}$	34	$V_{ol}$		0.15	0.4	V	B

\*) Type means: A = 100% tested, B = 100% correlation tested, C = Characterized on samples, D = Design parameter

Note: 1. If a logic high level is applied to this pin a minimum serial impedance of  $100\text{ }\Omega$  must be ensured for proper operation over full temperature range.

## Ordering Information

Extended Type Number	Package	Remarks
ATA5811-PLQC	QFN48	7 mm × 7 mm
ATA5812-PLQC	QFN48	7 mm × 7 mm

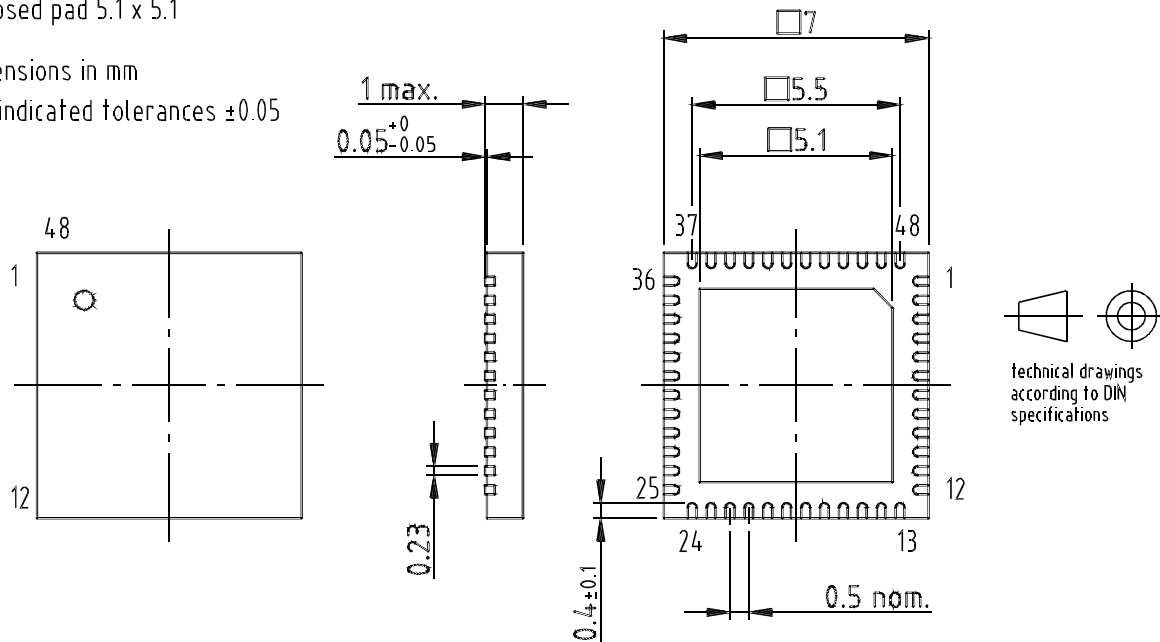
## Package Information

Package: QFN 48 7x7

Exposed pad 5.1 x 5.1

Dimensions in mm

Not indicated tolerances  $\pm 0.05$



Drawing-No.: 6.543-5089.02-4

Issue: 1; 14.01.03



<b>Table of Contents</b>	<b><i>Features</i> .....</b>	<b><i>1</i></b>
	<b><i>Applications</i> .....</b>	<b><i>1</i></b>
	<b><i>Benefits</i> .....</b>	<b><i>1</i></b>
	<b><i>General Description</i> .....</b>	<b><i>2</i></b>
	<b><i>Pin Description</i> .....</b>	<b><i>3</i></b>
	<b><i>Application Circuits</i> .....</b>	<b><i>6</i></b>
	Typical Key Fob or Sensor Application with 1 Battery .....	6
	Typical Car or Sensor Base-station Application .....	7
	Typical Key Fob Application, 2 Batteries .....	8
	RF Transceiver .....	9
	XTO .....	22
	Power Supply .....	26
	Microcontroller Interface .....	32
	Digital Control Logic .....	32
	Transceiver Configuration .....	45
	Operation Modes .....	48
	<b><i>Absolute Maximum Ratings</i> .....</b>	<b><i>62</i></b>
	<b><i>Thermal Resistance</i> .....</b>	<b><i>62</i></b>
	<b><i>Electrical Characteristics: General</i> .....</b>	<b><i>63</i></b>
	<b><i>Electrical Characteristic: 1-Battery Application</i> .....</b>	<b><i>75</i></b>
	<b><i>Electrical Characteristics: 2-Battery Application</i> .....</b>	<b><i>78</i></b>
	<b><i>Electrical Characteristics: Car Application</i> .....</b>	<b><i>80</i></b>
	<b><i>Digital Timing Characteristics</i> .....</b>	<b><i>82</i></b>
	<b><i>Digital Port Characteristics</i> .....</b>	<b><i>86</i></b>
	<b><i>Ordering Information</i> .....</b>	<b><i>88</i></b>
	<b><i>Package Information</i> .....</b>	<b><i>88</i></b>





## Atmel Corporation

2325 Orchard Parkway  
San Jose, CA 95131, USA  
Tel: 1(408) 441-0311  
Fax: 1(408) 487-2600

## Regional Headquarters

### Europe

Atmel Sarl  
Route des Arsenalux 41  
Case Postale 80  
CH-1705 Fribourg  
Switzerland  
Tel: (41) 26-426-5555  
Fax: (41) 26-426-5500

### Asia

Room 1219  
Chinachem Golden Plaza  
77 Mody Road Tsimshatsui  
East Kowloon  
Hong Kong  
Tel: (852) 2721-9778  
Fax: (852) 2722-1369

### Japan

9F, Tonetsu Shinkawa Bldg.  
1-24-8 Shinkawa  
Chuo-ku, Tokyo 104-0033  
Japan  
Tel: (81) 3-3523-3551  
Fax: (81) 3-3523-7581

## Atmel Operations

### Memory

2325 Orchard Parkway  
San Jose, CA 95131, USA  
Tel: 1(408) 441-0311  
Fax: 1(408) 436-4314

### Microcontrollers

2325 Orchard Parkway  
San Jose, CA 95131, USA  
Tel: 1(408) 441-0311  
Fax: 1(408) 436-4314

La Chantrerie  
BP 70602  
44306 Nantes Cedex 3, France  
Tel: (33) 2-40-18-18-18  
Fax: (33) 2-40-18-19-60

### ASIC/ASSP/Smart Cards

Zone Industrielle  
13106 Rousset Cedex, France  
Tel: (33) 4-42-53-60-00  
Fax: (33) 4-42-53-60-01

1150 East Cheyenne Mtn. Blvd.  
Colorado Springs, CO 80906, USA  
Tel: 1(719) 576-3300  
Fax: 1(719) 540-1759

Scottish Enterprise Technology Park  
Maxwell Building  
East Kilbride G75 0QR, Scotland  
Tel: (44) 1355-803-000  
Fax: (44) 1355-242-743

### RF/Automotive

Theresienstrasse 2  
Postfach 3535  
74025 Heilbronn, Germany  
Tel: (49) 71-31-67-0  
Fax: (49) 71-31-67-2340

1150 East Cheyenne Mtn. Blvd.  
Colorado Springs, CO 80906, USA  
Tel: 1(719) 576-3300  
Fax: 1(719) 540-1759

### Biometrics/Imaging/Hi-Rel MPU/ High Speed Converters/RF Datacom

Avenue de Rochepleine  
BP 123  
38521 Saint-Egreve Cedex, France  
Tel: (33) 4-76-58-30-00  
Fax: (33) 4-76-58-34-80

---

### Literature Requests

[www.atmel.com/literature](http://www.atmel.com/literature)

**Disclaimer:** Atmel Corporation makes no warranty for the use of its products, other than those expressly contained in the Company's standard warranty which is detailed in Atmel's Terms and Conditions located on the Company's web site. The Company assumes no responsibility for any errors which may appear in this document, reserves the right to change devices or specifications detailed herein at any time without notice, and does not make any commitment to update the information contained herein. No licenses to patents or other intellectual property of Atmel are granted by the Company in connection with the sale of Atmel products, expressly or by implication. Atmel's products are not authorized for use as critical components in life support devices or systems.

© Atmel Corporation 2004. All rights reserved.

Atmel® and combinations thereof are the registered trademarks of Atmel Corporation or its subsidiaries.

Other terms and product names may be the trademarks of others.



Printed on recycled paper.

4689B-RKE-04/04