

VOLTAGE REGULATOR WITH ON/OFF SWITCH

FEATURES

- Low Dropout Voltage
- Pass Transistor Terminals Available
- Very Low Standby Current (ON, No Load)
- Very Low (<200 nA) Current in OFF Mode
- Low Output Noise
- Internal Thermal Shutdown
- Short Circuit Protection
- Available on Tape and Reel

DESCRIPTION

The TK115xx series devices are low power, linear regulators with electronic ON/OFF switches. Both active HIGH and active LOW control pins are provided.

An internal PNP pass-transistor is used in order to achieve low dropout voltage (typically 200 mV at 80 mA load current). A base drive is available at pin 7 for connection of an external pass transistor should higher current (up to 1 A) or lower dropout voltage is required.

ABSOLUTE MAXIMUM RATINGS

Supply Voltage	16 V
Load Current	180 mA
Power Dissipation (Note 1)	600 mW
Storage Temperature Range	-55 to +150 °C
Operating Temperature Range	-30 to +80 °C
Lead Soldering Temp. (10 sec.)	260 °C
Junction Temperature	150 °C

Note 1: Derate output power by 4.8 mW/°C for operation above 25 °C.

APPLICATIONS

- Cordless Telephones
- Pagers
- Battery Powered Systems
- Personal Communications Equipment
- Portable Instrumentation
- Radio Control Systems
- Toys
- Low Voltage Systems
- Portable Consumer Equipment

An internal thermal shutdown circuit limits the junction temperature to below 150 °C. The load current is internally monitored, and the device will shut down in the presence of a short circuit at the output.

The TK115xx series is available in plastic surface mount SOP-8 packages.

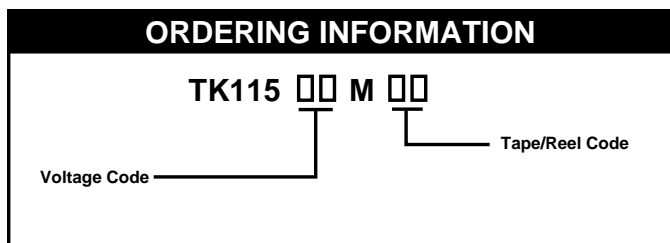

VOLTAGE CODE		TAPE/REEL CODE
30 = 3.0 V	45 = 4.5 V	BX : Bulk/Bag
32 = 3.25 V	47 = 4.75 V	TL : Tape Left
35 = 3.5 V	50 = 5.0 V	MG : Magazine
37 = 3.75 V	55 = 5.5 V	
40 = 4.0 V	80 = 8.0 V	

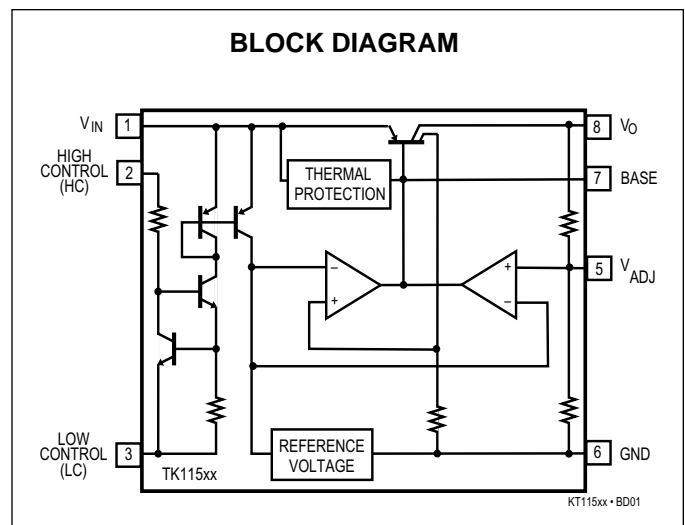
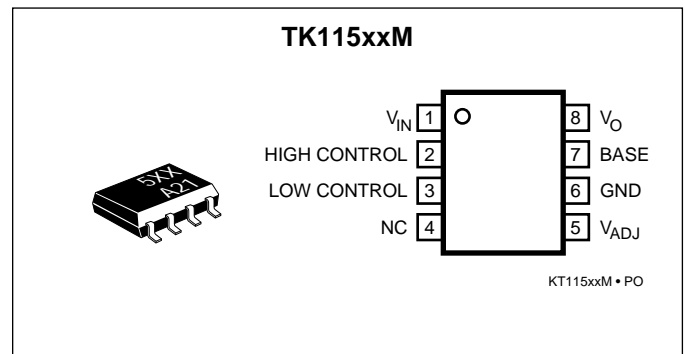

TK115xx

TEST CIRCUIT 1

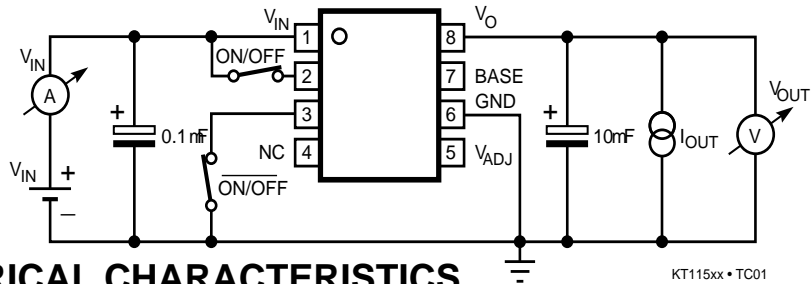

TK11530 ELECTRICAL CHARACTERISTICS

KT115xx • TC01

SYMBOL	PARAMETER	TEST CONDITIONS	MIN	TYP	MAX	UNITS
I_{CC1}	Supply Current 1	$V_{IN} = 4.0 \text{ V}, I_O = 0 \text{ mA}$		500	900	μA
I_{CC2}	Supply Current 2	$V_{IN} = 2.5 \text{ V}, I_O = 0 \text{ mA}$		1.4	2.5	mA
I_{CCS}	Standby Supply Current	$V_{IN} = 14 \text{ V}, \text{Output Off}$		0.2	2.0	μA
V_O	Output Voltage	$V_{IN} = 4.0 \text{ V}, I_O = 30 \text{ mA}$	2.9	3.0	3.1	V
V_{DROP}	Voltage Dropout	$I_O = 60 \text{ mA}$		0.13	0.35	V
I_O	Output Current	$V_O = 2.7 \text{ V}$	100	130		mA
I_{OR}	Recommended Output Current				100	mA
LinReg	Line Regulation	$V_{IN} = 4\text{V} \rightarrow 9 \text{ V}$		5.0	30	mV
LoaReg	Load Regulation	$I_O = 0 \text{ to } 30 \text{ mA}, V_{IN} = 4.0 \text{ V}$ (Note 1)		18	50	mV
		$I_O = 0 \text{ to } 60 \text{ mA}, V_{IN} = 4.0 \text{ V}$ (Note 1)		36	80	mV
RR	Ripple Regulation	100 mVrms, $f = 400 \text{ Hz}$, $V_{IN} = 4.5 \text{ V}, I_O = 10 \text{ mA}$		55		dB
$\Delta V_O / \Delta T_A$	V_O Temperature Coefficient	$V_{IN} = 4.5 \text{ V}, I_O = 10 \text{ mA}$, $-20 \text{ }^\circ\text{C} \leq T_A \leq 75 \text{ }^\circ\text{C}$		± 0.3		$\text{mV}/^\circ\text{C}$
V_{NO}	Output Noise Voltage	$10 \text{ Hz} \leq f \leq 100 \text{ kHz}, I_O = 10 \text{ mA}$		180		μVrms
I_B	Base Terminal Current	$V_{IN} = 4.0 \text{ V}$	6	14	35	mA
Active High Control Terminal						
I_{HC}	HC Terminal Current	Output On, Connect LC & GND		2	40	μA
V_{HC1}	HC Terminal Voltage 1	Output On, Connect LC & GND	2.4		V_{IN}	V
V_{HC2}	HC Terminal Voltage 2	Output Off, Connect LC & GND	0		0.6	V
Active Low Control Terminal						
I_{LC}	LC Terminal Current	Output On, Connect HC & GND		35	120	μA
V_{LC1}	LC Terminal Voltage 1	Output On, Connect HC & GND	0		$V_{IN} - 2.5$	V
V_{LC2}	LC Terminal Voltage 2	Output Off, Connect HC & GND	$V_{IN} - 0.2$		V_{IN}	V

Note 1: This is a pulse measurement where T_J is constant. The output change due to temperature is not included.

TK11532 ELECTRICAL CHARACTERISTICS

SYMBOL	PARAMETER	TEST CONDITIONS	MIN	TYP	MAX	UNITS
I_{CC1}	Supply Current 1	$V_{IN} = 4.2\text{ V}$, $I_O = 0\text{ mA}$		500	900	μA
I_{CC2}	Supply Current 2	$V_{IN} = 2.5\text{ V}$, $I_O = 0\text{ mA}$		1.4	2.5	mA
I_{CCS}	Standby Supply Current	$V_{IN} = 14\text{ V}$, Output Off		0.2	2.0	μA
V_O	Output Voltage	$V_{IN} = 4.2\text{ V}$, $I_O = 30\text{ mA}$	3.15	3.25	3.35	V
V_{DROP}	Voltage Dropout	$I_O = 60\text{ mA}$		0.13	0.35	V
I_O	Output Current	$V_O = 2.95\text{ V}$	100	130		mA
I_{OR}	Recommended Output Current				100	mA
LinReg	Line Regulation	$V_{IN} = 4.2\text{ V} \rightarrow 9.2\text{ V}$		6.0	30	mV
LoaReg	Load Regulation	$I_O = 0\text{ to }30\text{ mA}$, $V_{IN} = 4.2\text{ V}$ (Note 1)		20	50	mV
		$I_O = 0\text{ to }60\text{ mA}$, $V_{IN} = 4.2\text{ V}$ (Note 1)		40	80	mV
RR	Ripple Regulation	100 mVrms, $f = 400\text{ Hz}$, $V_{IN} = 4.7\text{ V}$, $I_O = 10\text{ mA}$		55		dB
$\Delta V_O / \Delta T_A$	V_O Temperature Coefficient	$V_{IN} = 4.7\text{ V}$, $I_O = 10\text{ mA}$, $-20\text{ }^\circ\text{C} \leq T_A \leq 75\text{ }^\circ\text{C}$		± 0.3		mV/ $^\circ\text{C}$
V_{NO}	Output Noise Voltage	10 Hz $\leq f \leq$ 100 kHz, $I_O = 10\text{ mA}$		180		μVrms
I_B	Base Terminal Current	$V_{IN} = 4.2\text{ V}$	6	14	35	mA
Active High Control Terminal						
I_{HC}	HC Terminal Current	Output On, Connect LC & GND		2	40	μA
V_{HC1}	HC Terminal Voltage 1	Output On, Connect LC & GND	2.4		V_{IN}	V
V_{HC2}	HC Terminal Voltage 2	Output Off, Connect LC & GND	0		0.6	V
Active Low Control Terminal						
I_{LC}	LC Terminal Current	Output On, Connect HC & GND		35	120	μA
V_{LC1}	LC Terminal Voltage 1	Output On, Connect HC & GND	0		$V_{IN}-2.5$	V
V_{LC2}	LC Terminal Voltage 2	Output Off, Connect HC & GND	$V_{IN}-0.2$		V_{IN}	V

Note 1: This is a pulse measurement where T_j is constant. The output change due to temperature is not included.

TK11535 ELECTRICAL CHARACTERISTICS

SYMBOL	PARAMETER	TEST CONDITIONS	MIN	TYP	MAX	UNITS
I_{CC1}	Supply Current 1	$V_{IN} = 4.5\text{ V}$, $I_O = 0\text{ mA}$		500	900	μA
I_{CC2}	Supply Current 2	$V_{IN} = 2.5\text{ V}$, $I_O = 0\text{ mA}$		1.4	2.5	mA
I_{CCS}	Standby Supply Current	$V_{IN} = 14\text{ V}$, Output Off		0.2	2.0	μA
V_O	Output Voltage	$V_{IN} = 4.5\text{ V}$, $I_O = 30\text{ mA}$	3.38	3.5	3.62	V
V_{DROP}	Voltage Dropout	$I_O = 60\text{ mA}$		0.13	0.35	V
I_O	Output Current	$V_O = 3.2\text{ V}$	100	130		mA
I_{OR}	Recommended Output Current				100	mA
LinReg	Line Regulation	$V_{IN} = 4.5\text{ V} \rightarrow 9.5\text{ V}$		6.0	30	mV
LoaReg	Load Regulation	$I_O = 0\text{ to }30\text{ mA}$, $V_{IN} = 4.5\text{ V}$ (Note 1)		20	55	mV
		$I_O = 0\text{ to }60\text{ mA}$, $V_{IN} = 4.5\text{ V}$ (Note 1)		40	95	mV
RR	Ripple Regulation	100 mVrms, $f = 400\text{ Hz}$, $V_{IN} = 5.0\text{ V}$, $I_O = 10\text{ mA}$		55		dB
$\Delta V_O/\Delta T_A$	V_O Temperature Coefficient	$V_{IN} = 5.0\text{ V}$, $I_O = 10\text{ mA}$, $-20\text{ }^\circ\text{C} \leq T_A \leq 75\text{ }^\circ\text{C}$		± 0.3		mV/ $^\circ\text{C}$
V_{NO}	Output Noise Voltage	10 Hz $\leq f \leq$ 100 kHz, $I_O = 10\text{ mA}$		180		μVrms
I_B	Base Terminal Current	$V_{IN} = 4.5\text{ V}$	6	14	35	mA
Active High Control Terminal						
I_{HC}	HC Terminal Current	Output On, Connect LC & GND		2	40	μA
V_{HC1}	HC Terminal Voltage 1	Output On, Connect LC & GND	2.4		V_{IN}	V
V_{HC2}	HC Terminal Voltage 2	Output Off, Connect LC & GND	0		0.6	V
Active Low Control Terminal						
I_{LC}	LC Terminal Current	Output On, Connect HC & GND		35	120	μA
V_{LC1}	LC Terminal Voltage 1	Output On, Connect HC & GND	0		$V_{IN}-2.5$	V
V_{LC2}	LC Terminal Voltage 2	Output Off, Connect HC & GND	$V_{IN}-0.2$		V_{IN}	V

Note 1: This is a pulse measurement where T_j is constant. The output change due to temperature is not included.

TK11537 ELECTRICAL CHARACTERISTICS

SYMBOL	PARAMETER	TEST CONDITIONS	MIN	TYP	MAX	UNITS
I_{CC1}	Supply Current 1	$V_{IN} = 4.75 \text{ V}$, $I_O = 0 \text{ mA}$		500	900	μA
I_{CC2}	Supply Current 2	$V_{IN} = 3.3 \text{ V}$, $I_O = 0 \text{ mA}$		1.4	2.5	mA
I_{CCS}	Standby Supply Current	$V_{IN} = 14 \text{ V}$, Output Off		0.2	2.0	μA
V_O	Output Voltage	$V_{IN} = 4.75 \text{ V}$, $I_O = 30 \text{ mA}$	3.625	3.75	3.88	V
V_{DROP}	Voltage Dropout	$I_O = 60 \text{ mA}$		0.13	0.35	V
I_O	Output Current	$V_O = 3.45 \text{ V}$	100	130		mA
I_{OR}	Recommended Output Current				100	mA
LinReg	Line Regulation	$V_{IN} = 4.75 \text{ V} \rightarrow 9.75 \text{ V}$		6.0	30	mV
LoaReg	Load Regulation	$I_O = 0 \text{ to } 30 \text{ mA}$, $V_{IN} = 4.75 \text{ V}$ (Note 1)		20	55	mV
		$I_O = 0 \text{ to } 60 \text{ mA}$, $V_{IN} = 4.75 \text{ V}$ (Note 1)		40	95	mV
RR	Ripple Regulation	100 mVrms, $f = 400 \text{ Hz}$, $V_{IN} = 5.25 \text{ V}$, $I_O = 10 \text{ mA}$		55		dB
$\Delta V_O / \Delta T_A$	V_O Temperature Coefficient	$V_{IN} = 5.25 \text{ V}$, $I_O = 10 \text{ mA}$, $-20 \text{ }^\circ\text{C} \leq T_A \leq 75 \text{ }^\circ\text{C}$		± 0.3		$\text{mV}/^\circ\text{C}$
V_{NO}	Output Noise Voltage	$10 \text{ Hz} \leq f \leq 100 \text{ kHz}$, $I_O = 10 \text{ mA}$		180		μVrms
I_B	Base Terminal Current	$V_{IN} = 4.75 \text{ V}$	6	14	35	mA
Active High Control Terminal						
I_{HC}	HC Terminal Current	Output On, Connect LC & GND		2	40	μA
V_{HC1}	HC Terminal Voltage 1	Output On, Connect LC & GND	2.4		V_{IN}	V
V_{HC2}	HC Terminal Voltage 2	Output Off, Connect LC & GND	0		0.6	V
Active Low Control Terminal						
I_{LC}	LC Terminal Current	Output On, Connect HC & GND		35	120	μA
V_{LC1}	LC Terminal Voltage 1	Output On, Connect HC & GND	0		$V_{IN}-2.5$	V
V_{LC2}	LC Terminal Voltage 2	Output Off, Connect HC & GND	$V_{IN}-0.2$		V_{IN}	V

Note 1: This is a pulse measurement where T_j is constant. The output change due to temperature is not included.

TK11540 ELECTRICAL CHARACTERISTICS

SYMBOL	PARAMETER	TEST CONDITIONS	MIN	TYP	MAX	UNITS
I_{CC1}	Supply Current 1	$V_{IN} = 5.0 \text{ V}$, $I_O = 0 \text{ mA}$		500	900	μA
I_{CC2}	Supply Current 2	$V_{IN} = 3.0 \text{ V}$, $I_O = 0 \text{ mA}$		1.4	2.5	mA
I_{CCS}	Standby Supply Current	$V_{IN} = 14 \text{ V}$, Output Off		0.2	2.0	μA
V_O	Output Voltage	$V_{IN} = 5.0 \text{ V}$, $I_O = 30 \text{ mA}$	3.88	4.0	4.12	V
V_{DROP}	Voltage Dropout	$I_O = 60 \text{ mA}$		0.13	0.35	V
I_O	Output Current	$V_O = 3.7 \text{ V}$	100	130		mA
I_{OR}	Recommended Output Current				100	mA
LinReg	Line Regulation	$V_{IN} = 5.0 \text{ V} \rightarrow 10.0 \text{ V}$		8.0	40	mV
LoaReg	Load Regulation	$I_O = 0 \text{ to } 30 \text{ mA}$, $V_{IN} = 5.0 \text{ V}$ (Note 1)		24	60	mV
		$I_O = 0 \text{ to } 60 \text{ mA}$, $V_{IN} = 5.0 \text{ V}$ (Note 1)		48	100	mV
RR	Ripple Regulation	100 mVrms, $f = 400 \text{ Hz}$, $V_{IN} = 5.5 \text{ V}$, $I_O = 10 \text{ mA}$		55		dB
$\Delta V_O / \Delta T_A$	V_O Temperature Coefficient	$V_{IN} = 5.5 \text{ V}$, $I_O = 10 \text{ mA}$, $-20 \text{ }^\circ\text{C} \leq T_A \leq 75 \text{ }^\circ\text{C}$		± 0.4		mV/ $^\circ\text{C}$
V_{NO}	Output Noise Voltage	10 Hz $\leq f \leq$ 100 kHz, $I_O = 10 \text{ mA}$		180		μVrms
I_B	Base Terminal Current	$V_{IN} = 5.0 \text{ V}$	6	14	35	mA
Active High Control Terminal						
I_{HC}	HC Terminal Current	Output On, Connect LC & GND		2	40	μA
V_{HC1}	HC Terminal Voltage 1	Output On, Connect LC & GND	2.4		V_{IN}	V
V_{HC2}	HC Terminal Voltage 2	Output Off, Connect LC & GND	0		0.6	V
Active Low Control Terminal						
I_{LC}	LC Terminal Current	Output On, Connect HC & GND		35	120	μA
V_{LC1}	LC Terminal Voltage 1	Output On, Connect HC & GND	0		$V_{IN}-2.5$	V
V_{LC2}	LC Terminal Voltage 2	Output Off, Connect HC & GND	$V_{IN}-0.2$		V_{IN}	V

Note 1: This is a pulse measurement where T_j is constant. The output change due to temperature is not included.

TK11545 ELECTRICAL CHARACTERISTICS

SYMBOL	PARAMETER	TEST CONDITIONS	MIN	TYP	MAX	UNITS
I_{CC1}	Supply Current 1	$V_{IN} = 5.5\text{ V}$, $I_O = 0\text{ mA}$		500	900	μA
I_{CC2}	Supply Current 2	$V_{IN} = 3.5\text{ V}$, $I_O = 0\text{ mA}$		1.4	2.5	mA
I_{CCS}	Standby Supply Current	$V_{IN} = 14\text{ V}$, Output Off		0.2	2.0	μA
V_O	Output Voltage	$V_{IN} = 5.5\text{ V}$, $I_O = 30\text{ mA}$	4.36	4.5	4.64	V
V_{DROP}	Voltage Dropout	$I_O = 60\text{ mA}$		0.13	0.35	V
I_O	Output Current	$V_O = 4.2\text{ V}$	100	130		mA
I_{OR}	Recommended Output Current				100	mA
LinReg	Line Regulation	$V_{IN} = 5.5\text{ V} \rightarrow 10.5\text{ V}$		8.0	40	mV
LoaReg	Load Regulation	$I_O = 0\text{ to }30\text{ mA}$, $V_{IN} = 5.5\text{ V}$ (Note 1)		25	65	mV
		$I_O = 0\text{ to }60\text{ mA}$, $V_{IN} = 5.5\text{ V}$ (Note 1)		55	110	mV
RR	Ripple Regulation	100 mVrms, $f = 400\text{ Hz}$, $V_{IN} = 6.0\text{ V}$, $I_O = 10\text{ mA}$		55		dB
$\Delta V_O / \Delta T_A$	V_O Temperature Coefficient	$V_{IN} = 6.0\text{ V}$, $I_O = 10\text{ mA}$, $-20\text{ }^\circ\text{C} \leq T_A \leq 75\text{ }^\circ\text{C}$		± 0.5		mV/ $^\circ\text{C}$
V_{NO}	Output Noise Voltage	10 Hz $\leq f \leq$ 100 kHz, $I_O = 10\text{ mA}$		180		μVrms
I_B	Base Terminal Current	$V_{IN} = 5.5\text{ V}$	6	14	35	mA
Active High Control Terminal						
I_{HC}	HC Terminal Current	Output On, Connect LC & GND		2	40	μA
V_{HC1}	HC Terminal Voltage 1	Output On, Connect LC & GND	2.4		V_{IN}	V
V_{HC2}	HC Terminal Voltage 2	Output Off, Connect LC & GND	0		0.6	V
Active Low Control Terminal						
I_{LC}	LC Terminal Current	Output On, Connect HC & GND		35	120	μA
V_{LC1}	LC Terminal Voltage 1	Output On, Connect HC & GND	0		$V_{IN}-2.5$	V
V_{LC2}	LC Terminal Voltage 2	Output Off, Connect HC & GND	$V_{IN}-0.2$		V_{IN}	V

Note 1: This is a pulse measurement where T_j is constant. The output change due to temperature is not included.

TK11547 ELECTRICAL CHARACTERISTICS

SYMBOL	PARAMETER	TEST CONDITIONS	MIN	TYP	MAX	UNITS
I_{CC1}	Supply Current 1	$V_{IN} = 5.7 \text{ V}, I_O = 0 \text{ mA}$		500	900	μA
I_{CC2}	Supply Current 2	$V_{IN} = 3.7 \text{ V}, I_O = 0 \text{ mA}$		1.4	2.5	mA
I_{CCS}	Standby Supply Current	$V_{IN} = 14 \text{ V}, \text{Output Off}$		0.2	2.0	μA
V_O	Output Voltage	$V_{IN} = 5.7 \text{ V}, I_O = 30 \text{ mA}$	4.6	4.75	4.9	V
V_{DROP}	Voltage Dropout	$I_O = 60 \text{ mA}$		0.13	0.35	V
I_O	Output Current	$V_O = 4.45 \text{ V}$	100	130		mA
I_{OR}	Recommended Output Current				100	mA
LinReg	Line Regulation	$V_{IN} = 5.7 \text{ V} \rightarrow 10.7 \text{ V}$		8.0	40	mV
LoaReg	Load Regulation	$I_O = 0 \text{ to } 30 \text{ mA}, V_{IN} = 5.7 \text{ V}$ (Note 1)		25	70	mV
		$I_O = 0 \text{ to } 60 \text{ mA}, V_{IN} = 5.7 \text{ V}$ (Note 1)		50	120	mV
RR	Ripple Regulation	100 mVrms, $f = 400 \text{ Hz}$, $V_{IN} = 6.2 \text{ V}, I_O = 10 \text{ mA}$		55		dB
$\Delta V_O / \Delta T_A$	V_O Temperature Coefficient	$V_{IN} = 6.2 \text{ V}, I_O = 10 \text{ mA}$, $-20 \text{ }^\circ\text{C} \leq T_A \leq 75 \text{ }^\circ\text{C}$		± 0.6		mV/ $^\circ\text{C}$
V_{NO}	Output Noise Voltage	10 Hz $\leq f \leq$ 100 kHz, $I_O = 10 \text{ mA}$		180		μVrms
I_B	Base Terminal Current	$V_{IN} = 5.7 \text{ V}$	6	14	35	mA
Active High Control Terminal						
I_{HC}	HC Terminal Current	Output On, Connect LC & GND		2	40	μA
V_{HC1}	HC Terminal Voltage 1	Output On, Connect LC & GND	2.4		V_{IN}	V
V_{HC2}	HC Terminal Voltage 2	Output Off, Connect LC & GND	0		0.6	V
Active Low Control Terminal						
I_{LC}	LC Terminal Current	Output On, Connect HC & GND		35	120	μA
V_{LC1}	LC Terminal Voltage 1	Output On, Connect HC & GND	0		$V_{IN}-2.5$	V
V_{LC2}	LC Terminal Voltage 2	Output Off, Connect HC & GND	$V_{IN}-0.2$		V_{IN}	V

Note 1: This is a pulse measurement where T_j is constant. The output change due to temperature is not included.

TK11550 ELECTRICAL CHARACTERISTICS

SYMBOL	PARAMETER	TEST CONDITIONS	MIN	TYP	MAX	UNITS
I_{CC1}	Supply Current 1	$V_{IN} = 6.0 \text{ V}$, $I_O = 0 \text{ mA}$		500	900	μA
I_{CC2}	Supply Current 2	$V_{IN} = 4.0 \text{ V}$, $I_O = 0 \text{ mA}$		1.4	2.5	mA
I_{CCS}	Standby Supply Current	$V_{IN} = 14 \text{ V}$, Output Off		0.2	2.0	μA
V_O	Output Voltage	$V_{IN} = 6.0 \text{ V}$, $I_O = 30 \text{ mA}$, $T_A = 25 \text{ }^\circ\text{C}$	4.85	5.0	5.15	V
V_{DROP}	Voltage Dropout	$I_O = 60 \text{ mA}$		0.13	0.35	V
I_O	Output Current	$V_O = 4.7 \text{ V}$	100	130		mA
I_{OR}	Recommended Output Current				100	mA
LinReg	Line Regulation	$V_{IN} = 6.0 \text{ V} \rightarrow 11 \text{ V}$		8.0	40	mV
LoaReg	Load Regulation	$I_O = 0 \text{ to } 30 \text{ mA}$, $V_{IN} = 6.0 \text{ V}$ (Note 1)		25	70	mV
		$I_O = 0 \text{ to } 60 \text{ mA}$, $V_{IN} = 6.0 \text{ V}$ (Note 1)		50	120	mV
RR	Ripple Regulation	100 mVrms, $f = 400 \text{ Hz}$, $V_{IN} = 6.5 \text{ V}$, $I_O = 10 \text{ mA}$		55		dB
$\Delta V_O / \Delta T_A$	V_O Temperature Coefficient	$V_{IN} = 6.5 \text{ V}$, $I_O = 10 \text{ mA}$, $-20 \text{ }^\circ\text{C} \leq T_A \leq 75 \text{ }^\circ\text{C}$		± 0.6		mV/ $^\circ\text{C}$
V_{NO}	Output Noise Voltage	10 Hz $\leq f \leq$ 100 kHz, $I_O = 10 \text{ mA}$		180		μVrms
I_B	Base Terminal Current	$V_{IN} = 6.0 \text{ V}$	6	14	35	mA
Active High Control Terminal						
I_{HC}	HC Terminal Current	Output On, Connect LC & GND		2	40	μA
V_{HC1}	HC Terminal Voltage 1	Output On, Connect LC & GND	2.4		V_{IN}	V
V_{HC2}	HC Terminal Voltage 2	Output Off, Connect LC & GND	0		0.6	V
Active Low Control Terminal						
I_{LC}	LC Terminal Current	Output On, Connect HC & GND		35	120	μA
V_{LC1}	LC Terminal Voltage 1	Output On, Connect HC & GND	0		$V_{IN}-2.5$	V
V_{LC2}	LC Terminal Voltage 2	Output Off, Connect HC & GND	$V_{IN}-0.2$		V_{IN}	V

Note 1: This is a pulse measurement where T_j is constant. The output change due to temperature is not included.

TK11555 ELECTRICAL CHARACTERISTICS

SYMBOL	PARAMETER	TEST CONDITIONS	MIN	TYP	MAX	UNITS
I_{CC1}	Supply Current 1	$V_{IN} = 6.5 \text{ V}$, $I_O = 0 \text{ mA}$		500	900	μA
I_{CC2}	Supply Current 2	$V_{IN} = 4.5 \text{ V}$, $I_O = 0 \text{ mA}$		1.4	2.5	mA
I_{CCS}	Standby Supply Current	$V_{IN} = 14 \text{ V}$, Output Off		0.2	2.0	μA
V_O	Output Voltage	$V_{IN} = 6.5 \text{ V}$, $I_O = 30 \text{ mA}$	5.225	5.5	5.665	V
V_{DROP}	Voltage Dropout	$I_O = 60 \text{ mA}$		0.13	0.35	V
I_O	Output Current	$V_O = 5.2 \text{ V}$	100	130		mA
I_{OR}	Recommended Output Current				100	mA
LinReg	Line Regulation	$V_{IN} = 6.5 \text{ V} \rightarrow 11.5 \text{ V}$		8.0	40	mV
LoaReg	Load Regulation	$I_O = 0 \text{ to } 30 \text{ mA}$, $V_{IN} = 6.5 \text{ V}$ (Note 1)		25	70	mV
		$I_O = 0 \text{ to } 60 \text{ mA}$, $V_{IN} = 6.5 \text{ V}$ (Note 1)		50	120	mV
RR	Ripple Regulation	100 mVrms, $f = 400 \text{ Hz}$, $V_{IN} = 7.0 \text{ V}$, $I_O = 10 \text{ mA}$		55		dB
$\Delta V_O / \Delta T_A$	V_O Temperature Coefficient	$V_{IN} = 7.0 \text{ V}$, $I_O = 10 \text{ mA}$, $-20 \text{ }^\circ\text{C} \leq T_A \leq 75 \text{ }^\circ\text{C}$		± 0.6		mV/ $^\circ\text{C}$
V_{NO}	Output Noise Voltage	10 Hz $\leq f \leq$ 100 kHz, $I_O = 10 \text{ mA}$		180		μVrms
I_B	Base Terminal Current	$V_{IN} = 6.5 \text{ V}$	6	14	35	mA
Active High Control Terminal						
I_{HC}	HC Terminal Current	Output On, Connect LC & GND		2	40	μA
V_{HC1}	HC Terminal Voltage 1	Output On, Connect LC & GND	2.4		V_{IN}	V
V_{HC2}	HC Terminal Voltage 2	Output Off, Connect LC & GND	0		0.6	V
Active Low Control Terminal						
I_{LC}	LC Terminal Current	Output On, Connect HC & GND		35	120	μA
V_{LC1}	LC Terminal Voltage 1	Output On, Connect HC & GND	0		$V_{IN}-2.5$	V
V_{LC2}	LC Terminal Voltage 2	Output Off, Connect HC & GND	$V_{IN}-0.2$		V_{IN}	V

Note 1: This is a pulse measurement where T_j is constant. The output change due to temperature is not included.

TK11580 ELECTRICAL CHARACTERISTICS

SYMBOL	PARAMETER	TEST CONDITIONS	MIN	TYP	MAX	UNITS
I_{CC1}	Supply Current 1	$V_{IN} = 9.0\text{ V}$, $I_O = 0\text{ mA}$		500	900	μA
I_{CC2}	Supply Current 2	$V_{IN} = 7.0\text{ V}$, $I_O = 0\text{ mA}$		1.4	2.5	mA
I_{CCS}	Standby Supply Current	$V_{IN} = 14\text{ V}$, Output Off		0.2	2.0	μA
V_O	Output Voltage	$V_{IN} = 9.0\text{ V}$, $I_O = 30\text{ mA}$	7.76	8.0	8.24	V
V_{DROP}	Voltage Dropout	$I_O = 60\text{ mA}$		0.13	0.35	V
I_O	Output Current	$V_O = 7.7\text{ V}$	100	130		mA
I_{OR}	Recommended Output Current				100	mA
LinReg	Line Regulation	$V_{IN} = 9.0\text{ V} \rightarrow 14.0\text{ V}$		16.0	40	mV
LoaReg	Load Regulation	$I_O = 0\text{ to }30\text{ mA}$, $V_{IN} = 9.0\text{ V}$ (Note 1)		35	110	mV
		$I_O = 0\text{ to }60\text{ mA}$, $V_{IN} = 9.0\text{ V}$ (Note 1)		70	200	mV
RR	Ripple Regulation	100 mVrms, $f = 400\text{ Hz}$, $V_{IN} = 9.5\text{ V}$, $I_O = 10\text{ mA}$		55		dB
$\Delta V_O / \Delta T_A$	V_O Temperature Coefficient	$V_{IN} = 9.5\text{ V}$, $I_O = 10\text{ mA}$, $-20\text{ }^\circ\text{C} \leq T_A \leq 75\text{ }^\circ\text{C}$		± 1.0		mV/ $^\circ\text{C}$
V_{NO}	Output Noise Voltage	10 Hz $\leq f \leq$ 100 kHz, $I_O = 10\text{ mA}$		180		μVrms
I_B	Base Terminal Current	$V_{IN} = 9.0\text{ V}$	6	14	35	mA
Active High Control Terminal						
I_{HC}	HC Terminal Current	Output On, Connect LC & GND		2	40	μA
V_{HC1}	HC Terminal Voltage 1	Output On, Connect LC & GND	2.4		V_{IN}	V
V_{HC2}	HC Terminal Voltage 2	Output Off, Connect LC & GND	0		0.6	V
Active Low Control Terminal						
I_{LC}	LC Terminal Current	Output On, Connect HC & GND		35	120	μA
V_{LC1}	LC Terminal Voltage 1	Output On, Connect HC & GND	0		$V_{IN}-2.5$	V
V_{LC2}	LC Terminal Voltage 2	Output Off, Connect HC & GND	$V_{IN}-0.2$		V_{IN}	V

Note 1: This is a pulse measurement where T_j is constant. The output change due to temperature is not included.

TYPICAL PERFORMANCE CHARACTERISTICS

COMMON CHARACTERISTICS

$T_A = 25^\circ\text{C}$ unless otherwise specified

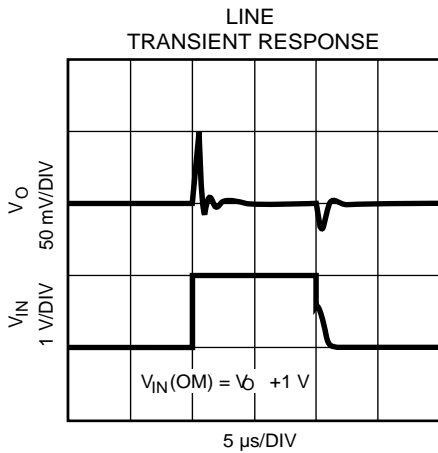
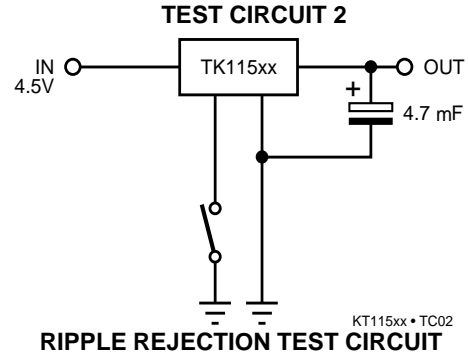
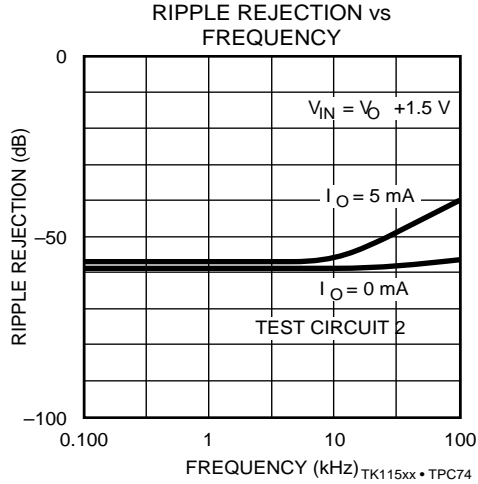

TK115xx • TPC71

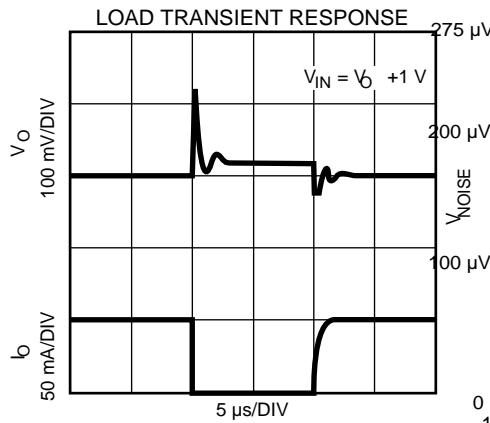

TK115xx • TPC72

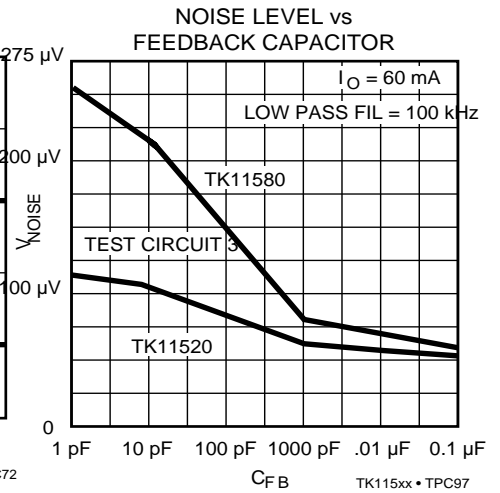

TK115xx • TPC97

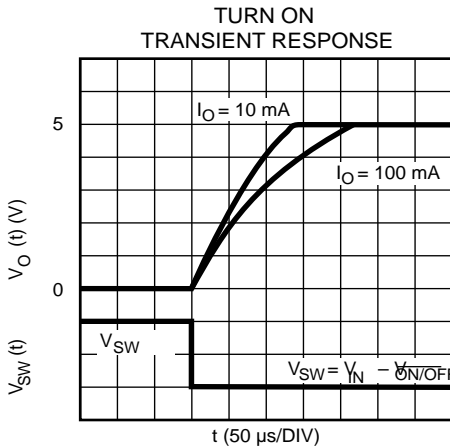

TK115xx • TPC73

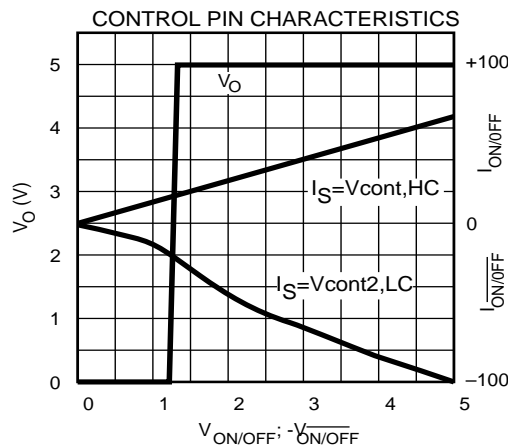

TK115xx • TPC75

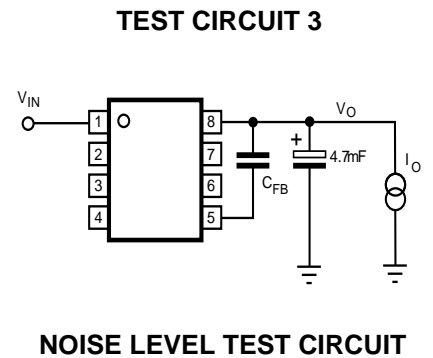

COMMON CHARACTERISTICS WITH EXTERNAL CURRENT BOOST TRANSISTOR (NEC 2SA733 OR TOSHIBA 2SA1244)

$T_A = 25\text{ }^\circ\text{C}$ unless otherwise specified

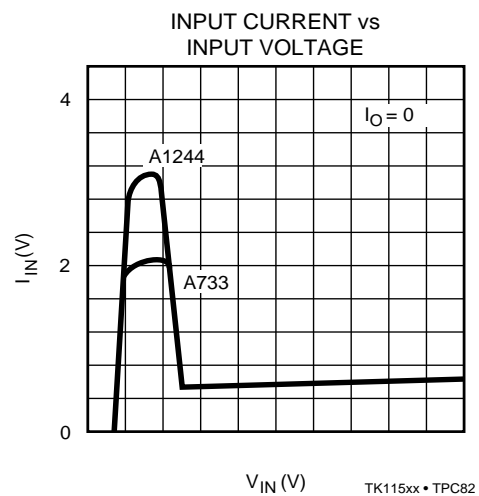
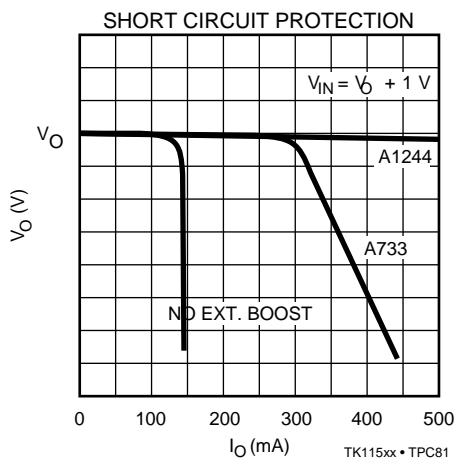
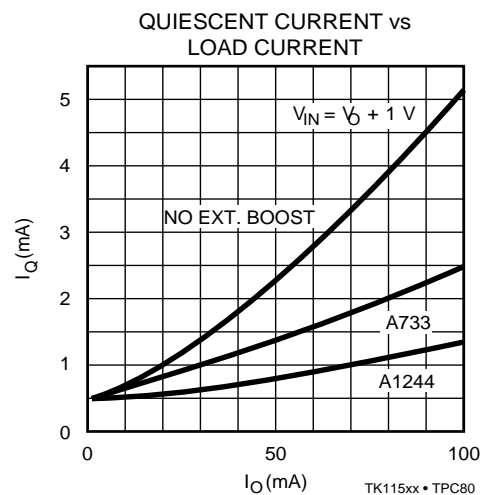
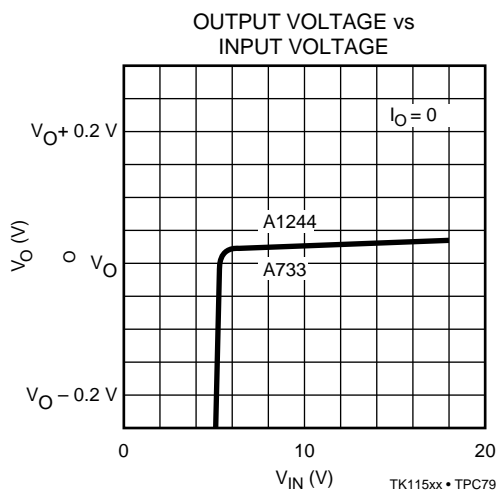
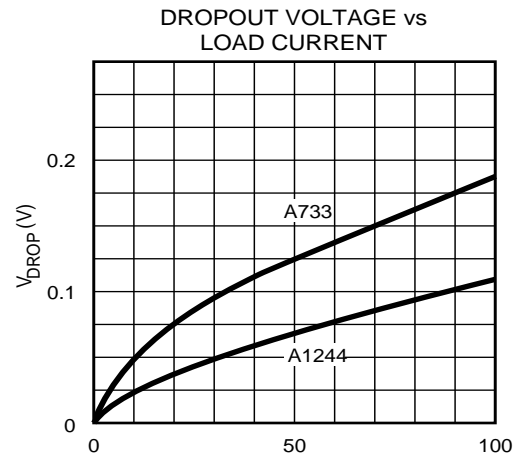
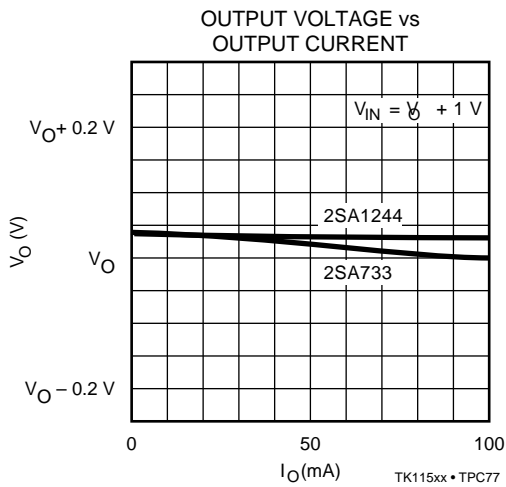

VOLTAGE ADJUSTMENT

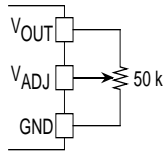

For large adjustment range use a 50 K potentiometer. This method gives good results when a voltage lower than the rated output is needed.

For small changes in output voltage use R1 to increase the output voltage or R2 to decrease the output voltage. The graph at right shows the approximate resistance values. The initial output voltage is indicated on the graph. (3 V = TK11530 etc.)

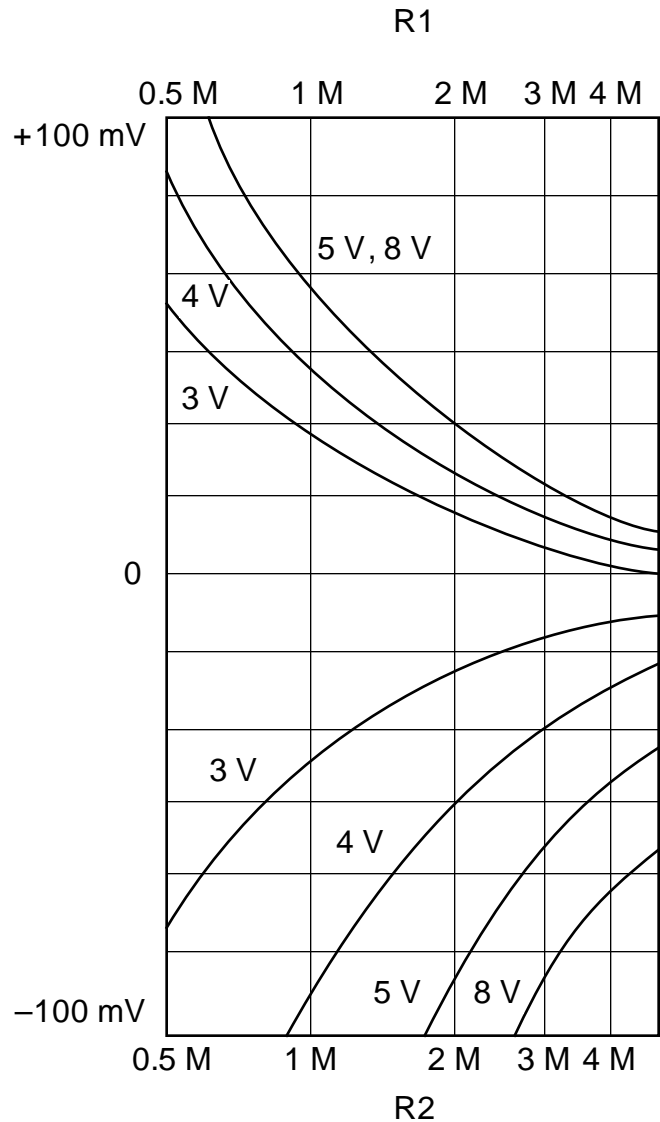
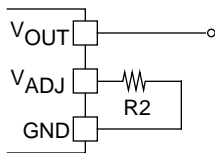
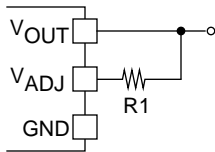

$T_A = 25\text{ }^\circ\text{C}$ unless otherwise specified

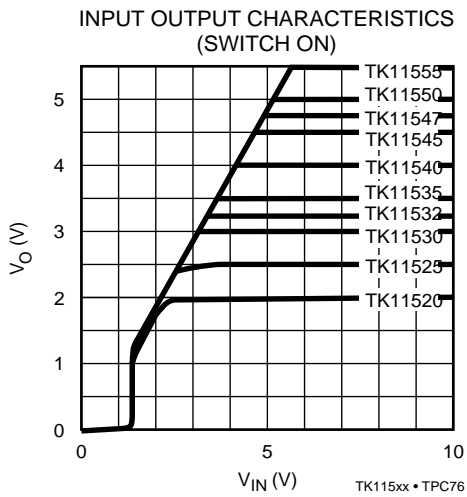
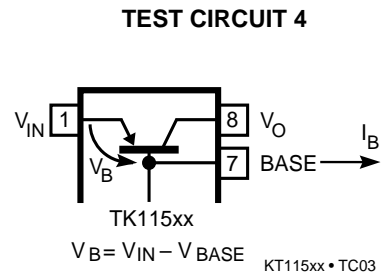
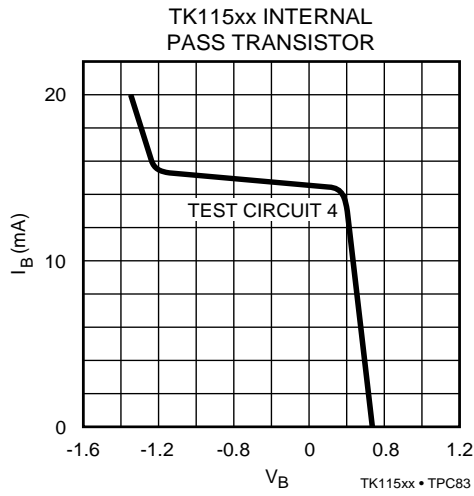

TYPICAL PERFORMANCE CHARACTERISTICS (CONT.)

TEMPERATURE CHARACTERISTICS

$T_A = 25^\circ\text{C}$ unless otherwise specified

TK11530
OUTPUT VOLTAGE vs
TEMPERATURE

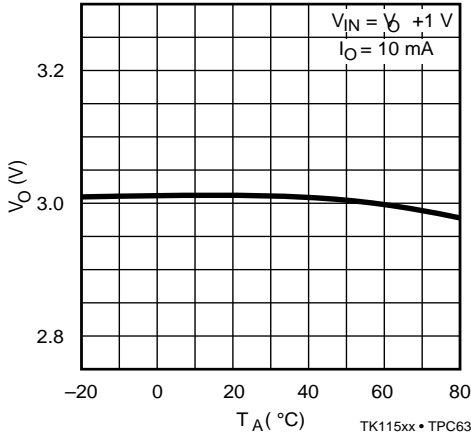

TK11532
OUTPUT VOLTAGE vs
TEMPERATURE

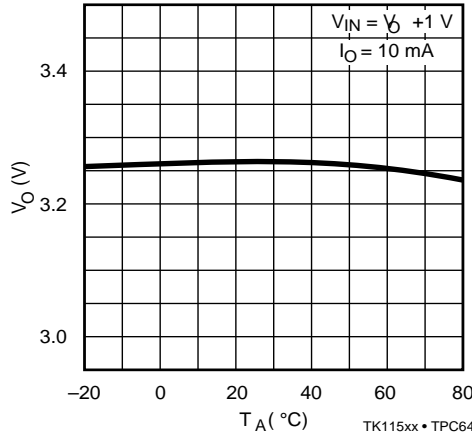

TK11535
OUTPUT VOLTAGE vs
TEMPERATURE

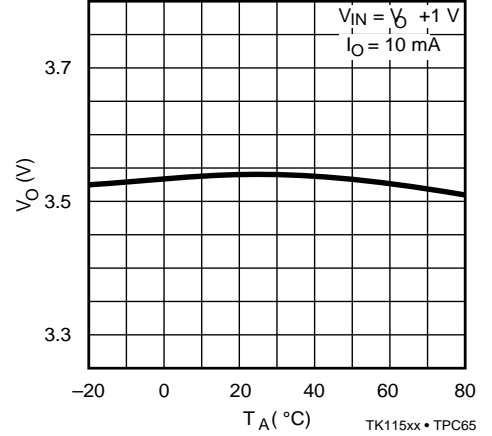

TK11537
OUTPUT VOLTAGE vs
TEMPERATURE

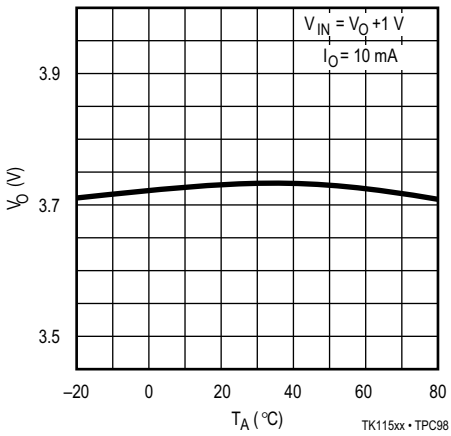

TK11540
OUTPUT VOLTAGE vs
TEMPERATURE

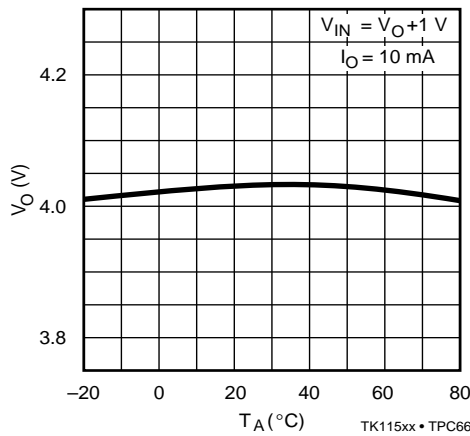

TK11545
OUTPUT VOLTAGE vs
TEMPERATURE

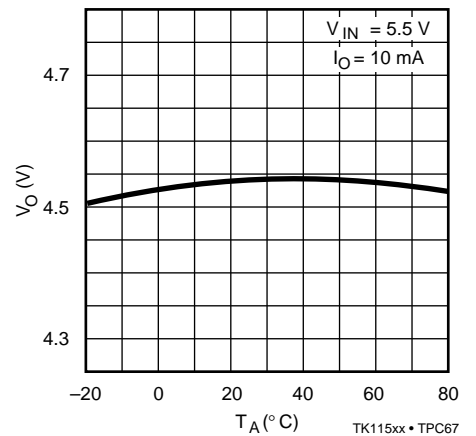

TK11547
OUTPUT VOLTAGE vs
TEMPERATURE

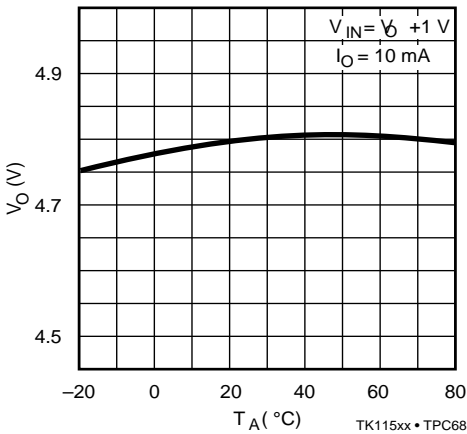

TK11550
OUTPUT VOLTAGE vs
TEMPERATURE

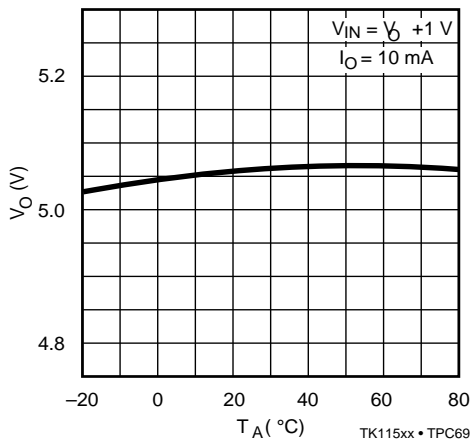

TK11555
OUTPUT VOLTAGE vs
TEMPERATURE

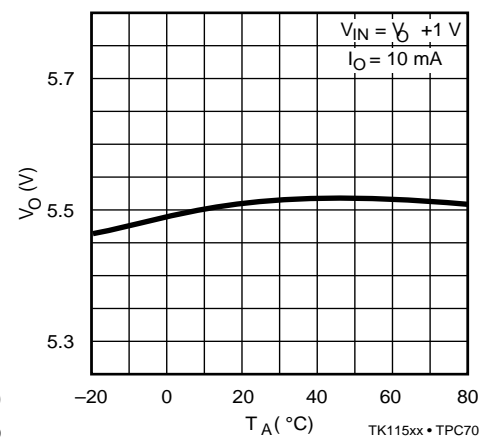

TYPICAL PERFORMANCE CHARACTERISTICS (CONT.)

TEMPERATURE CHARACTERISTICS (CONT.)

$T_A = 25\text{ }^\circ\text{C}$ unless otherwise specified

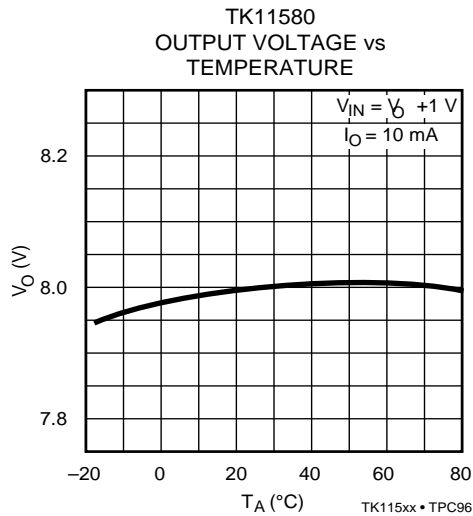

TK11530

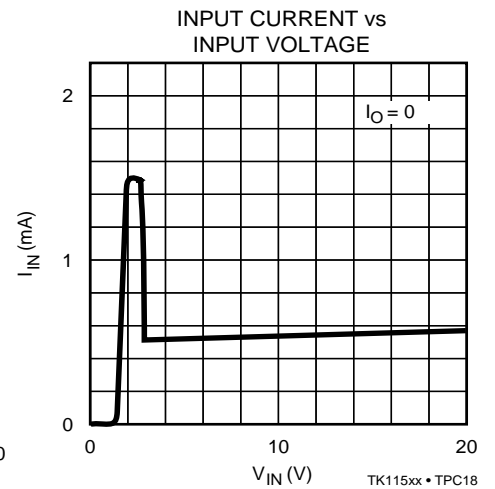
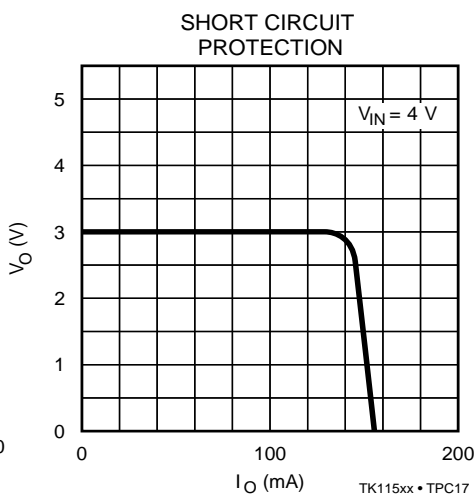
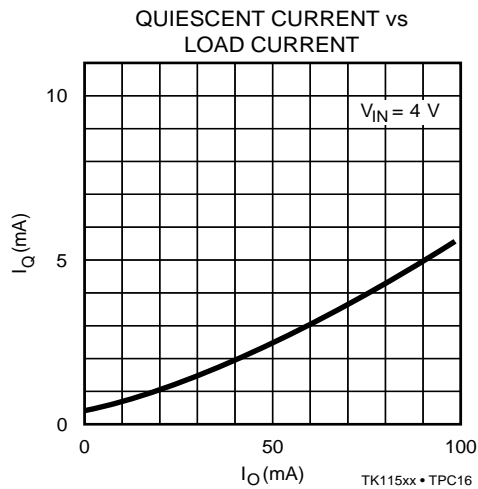
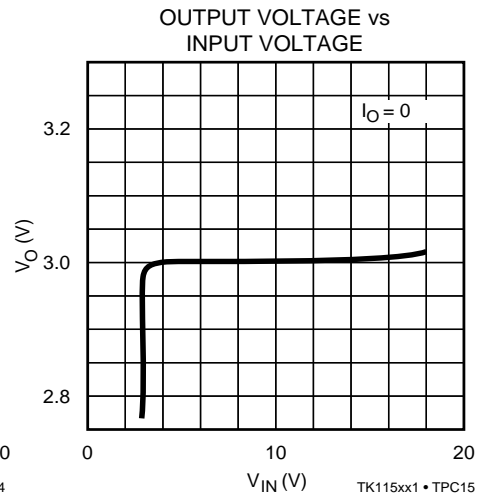
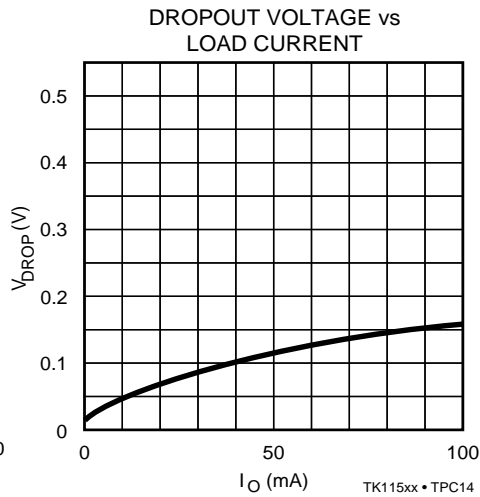
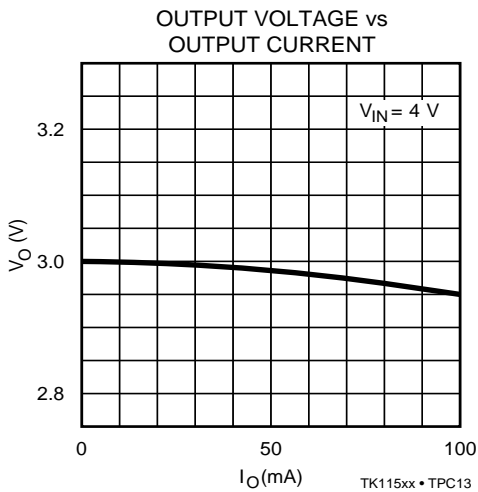

TYPICAL PERFORMANCE CHARACTERISTICS (CONT.)

TK11532

$T_A = 25\text{ }^\circ\text{C}$ unless otherwise specified

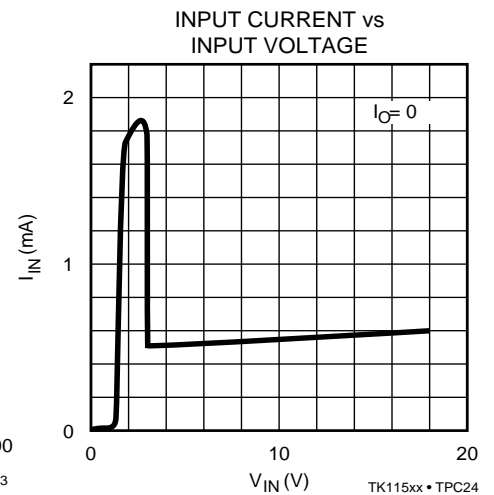
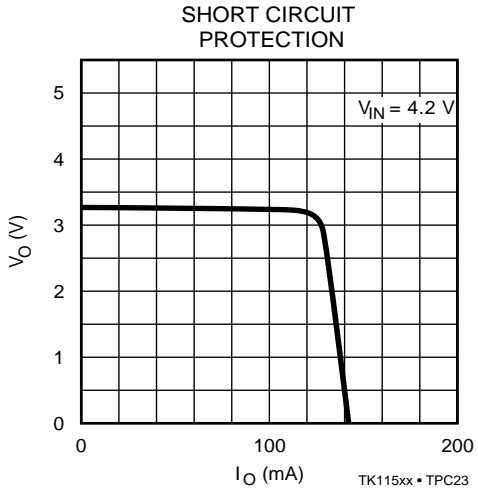
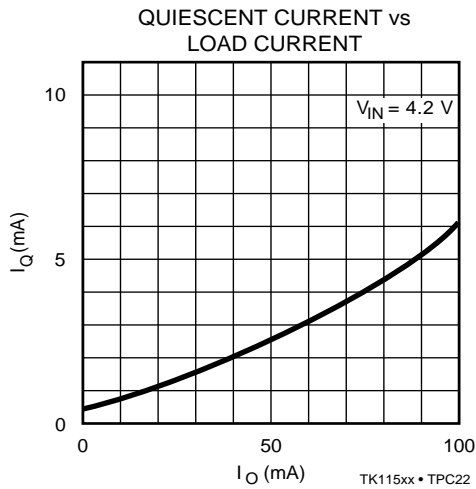
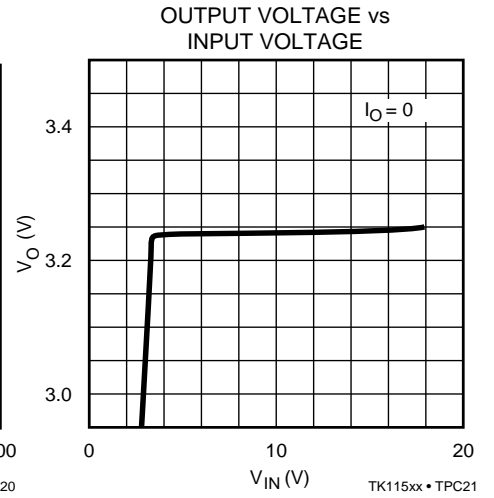
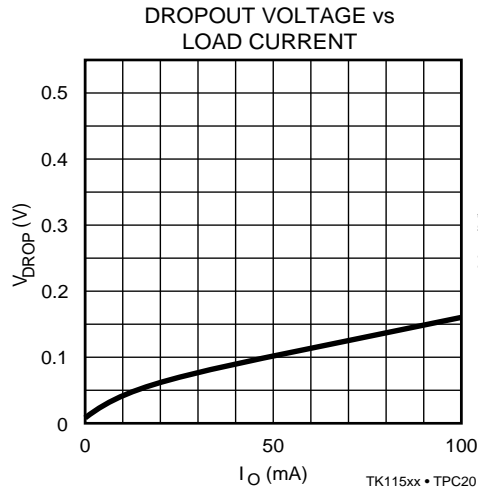
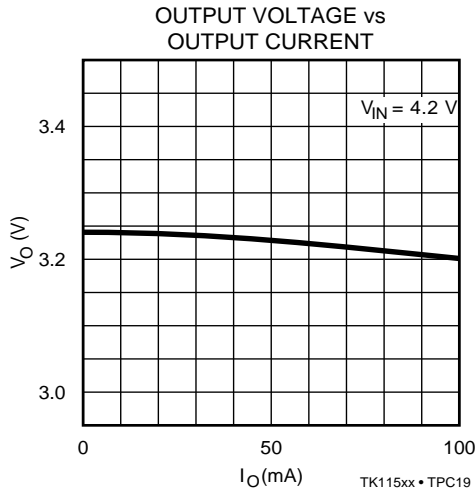

TK11535

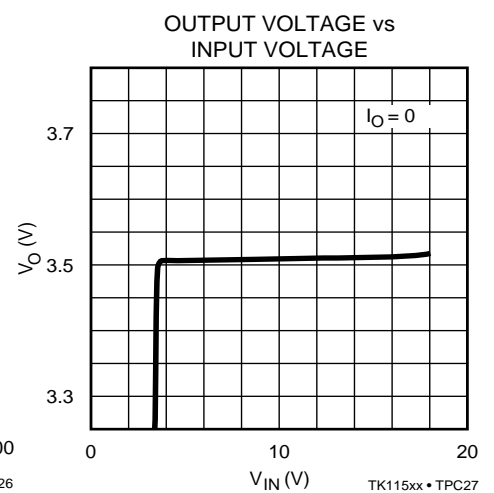
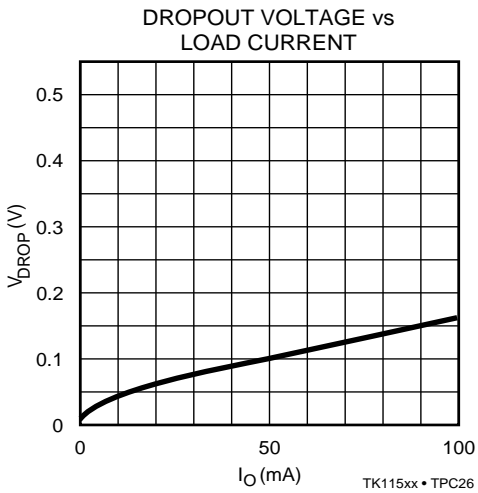
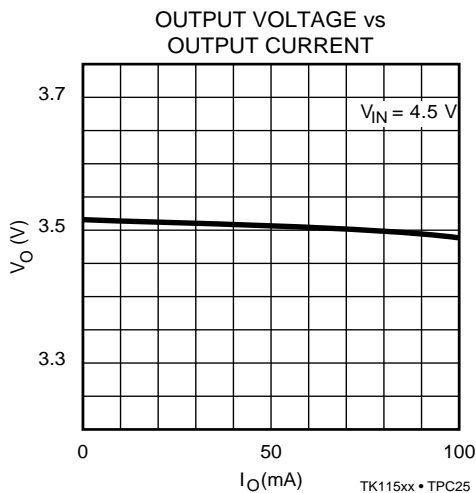

TYPICAL PERFORMANCE CHARACTERISTICS (CONT.)

TK11535 (CONT.)

$T_A = 25\text{ }^\circ\text{C}$ unless otherwise specified

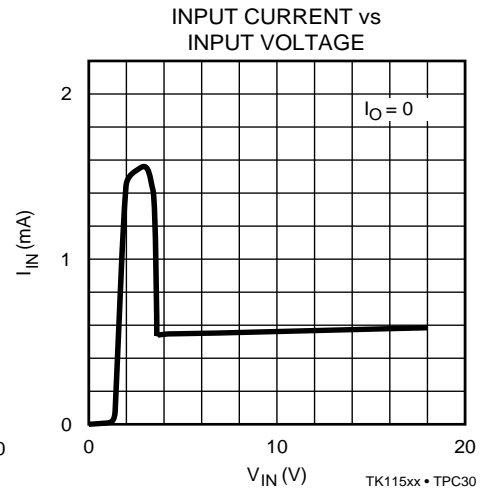
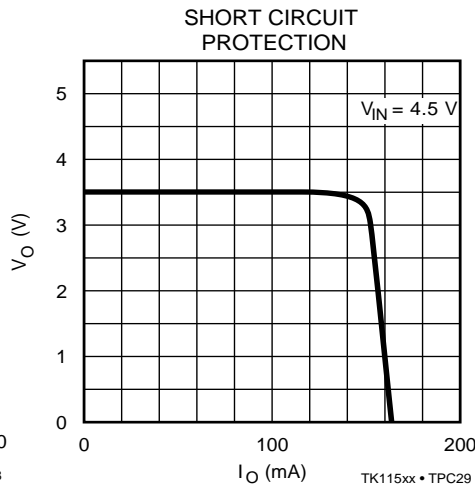
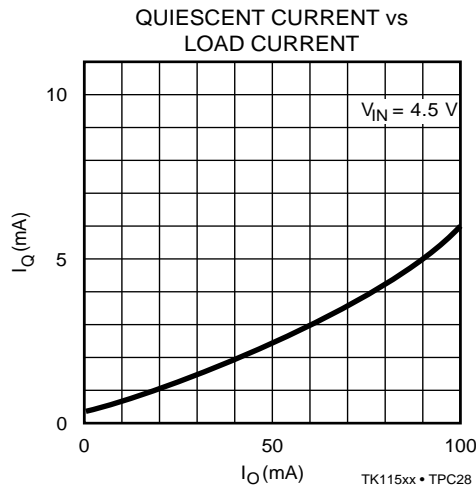

TK11537

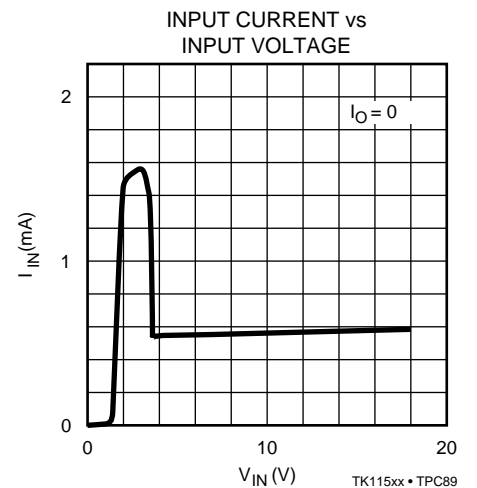
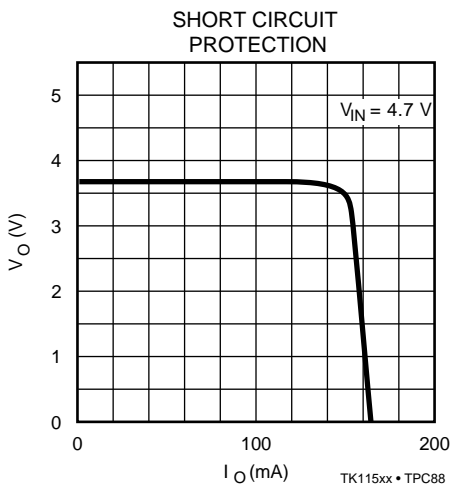
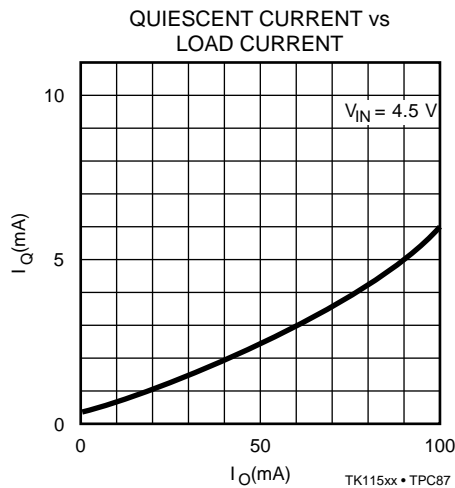
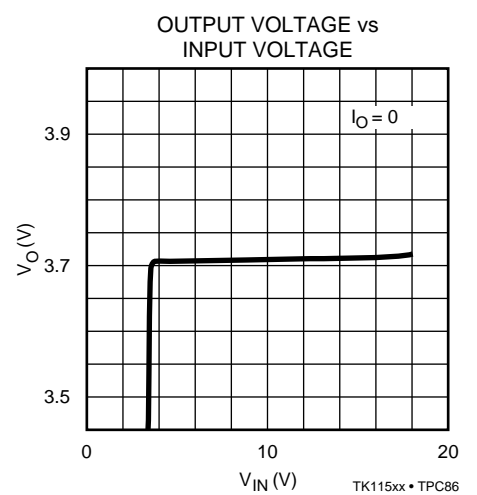
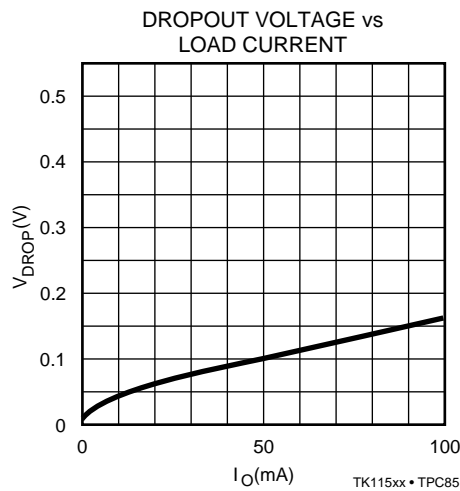
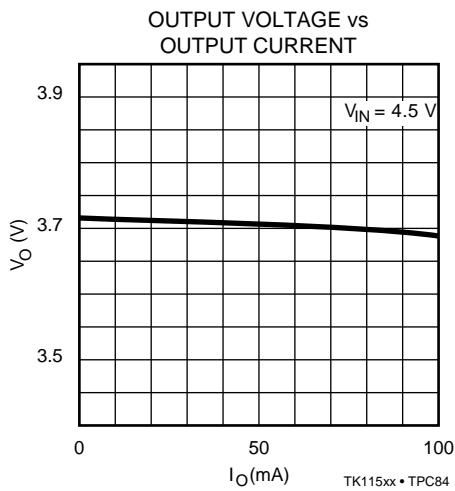

TK115xx

TYPICAL PERFORMANCE CHARACTERISTICS (CONT.)

TK11540

$T_A = 25\text{ }^\circ\text{C}$ unless otherwise specified

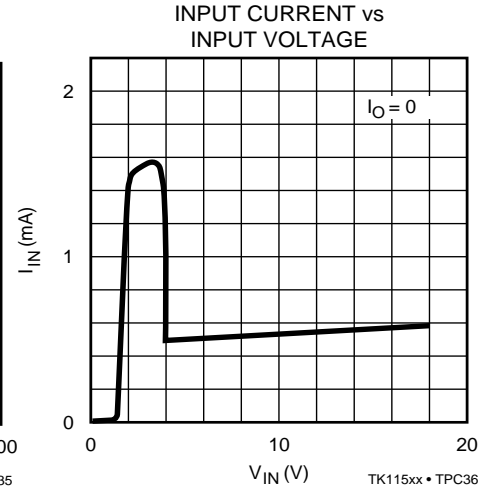
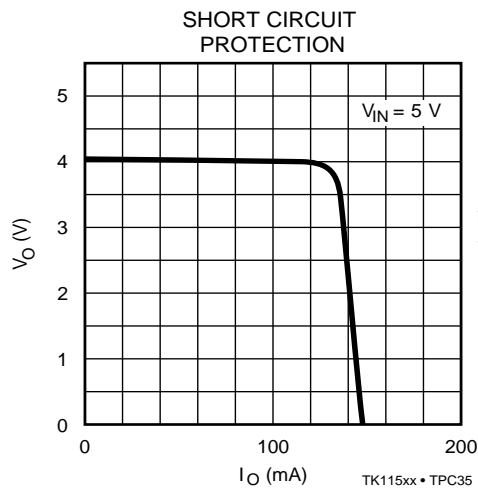
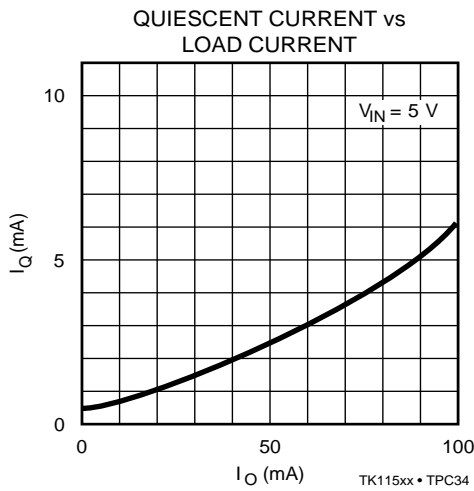
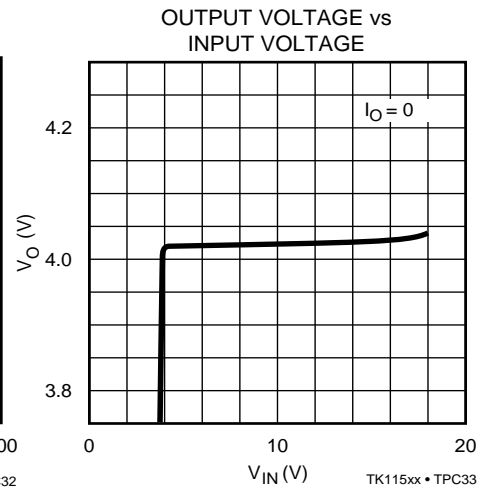
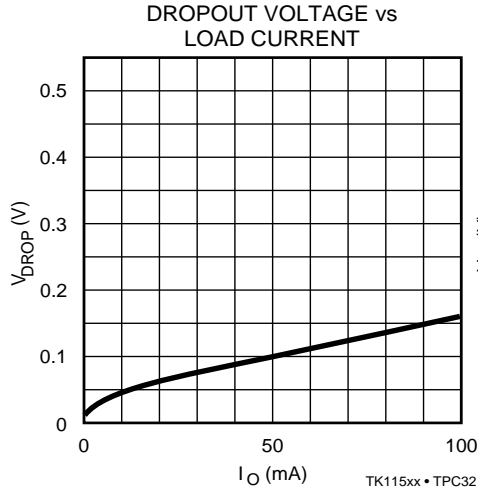
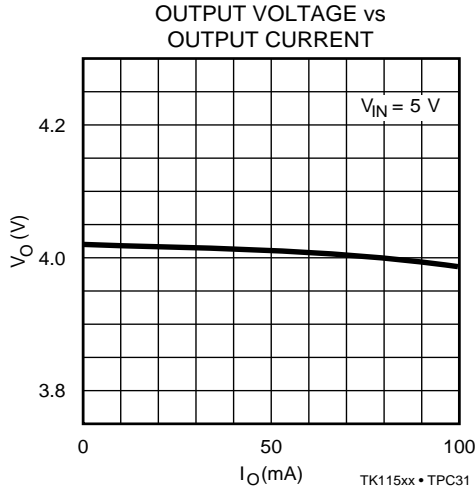

TK11545

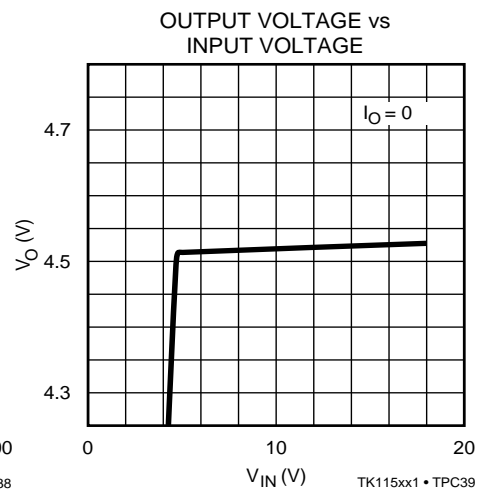
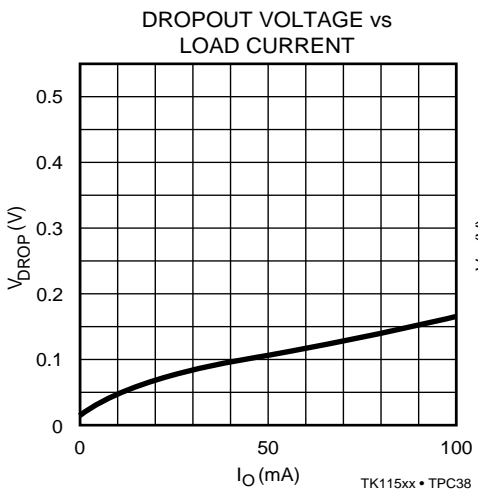
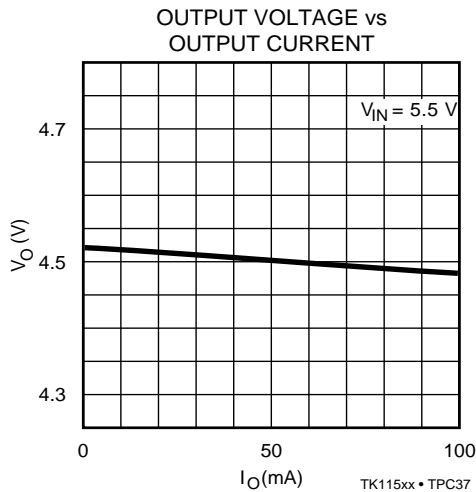

TYPICAL PERFORMANCE CHARACTERISTICS (CONT.)

TK11545 (CONT.)

$T_A = 25\text{ }^\circ\text{C}$ unless otherwise specified

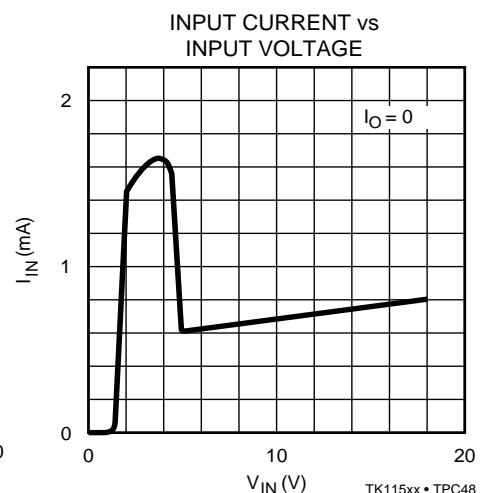
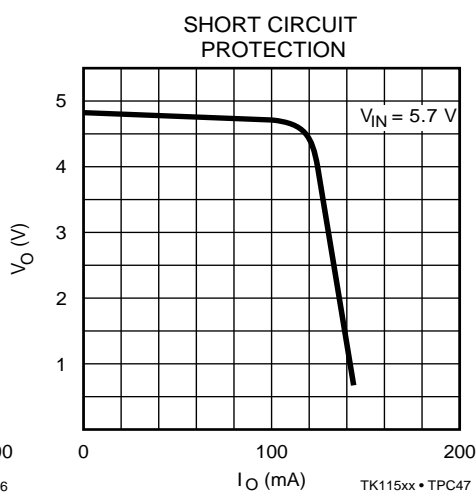
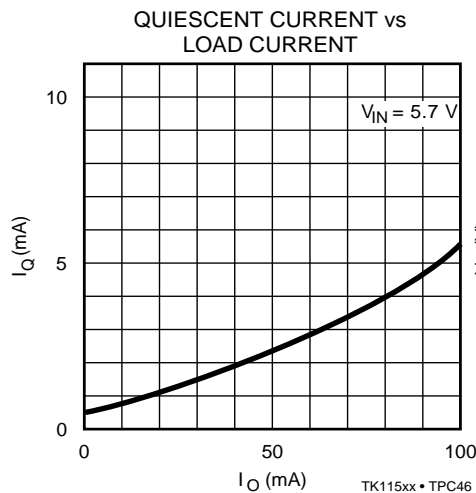
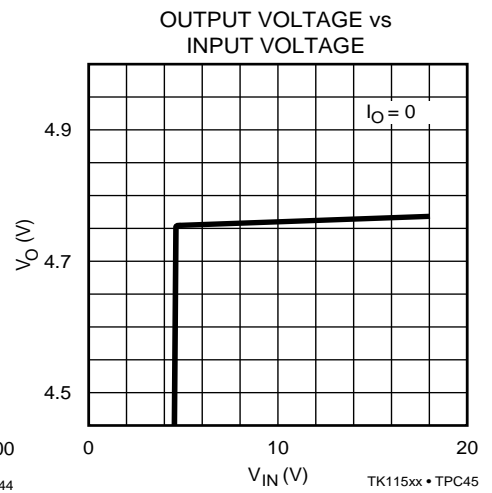
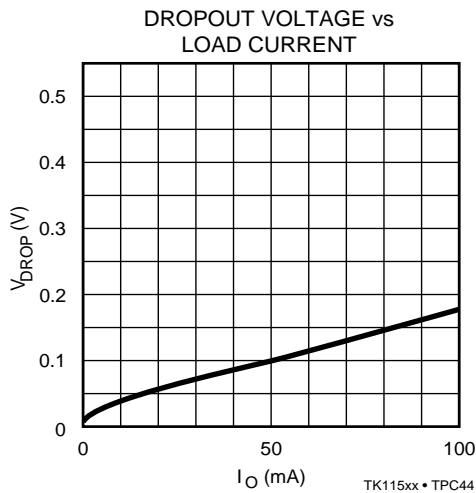
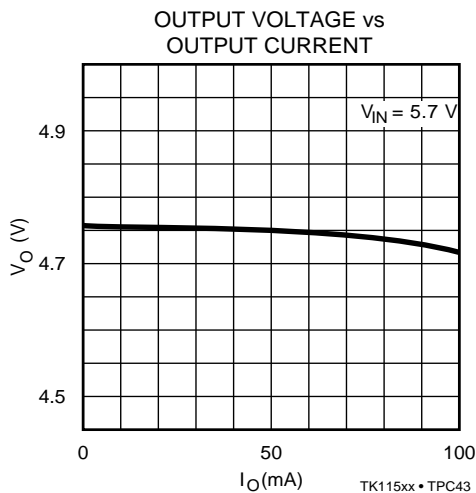
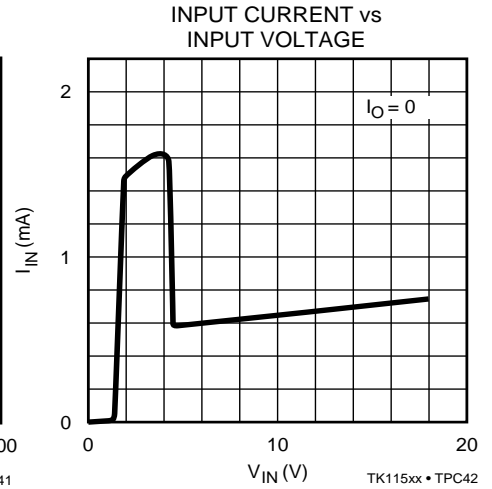
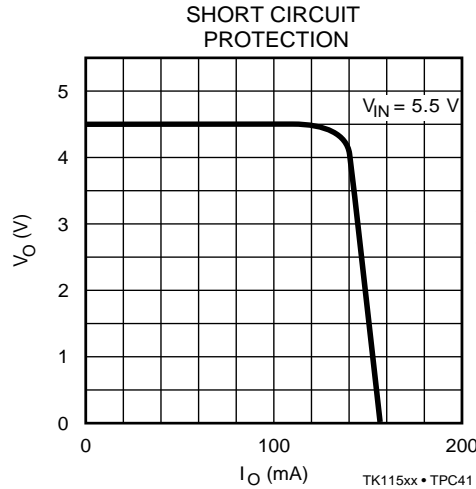
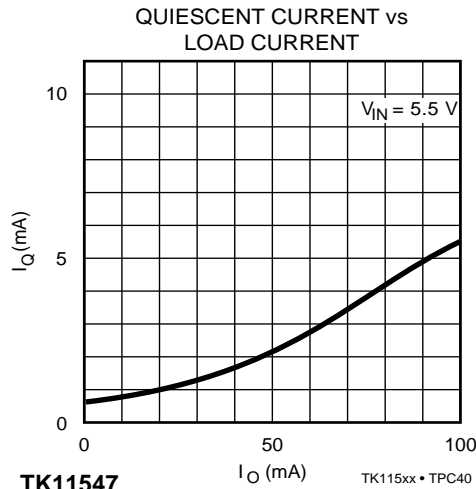

TK115xx

TYPICAL PERFORMANCE CHARACTERISTICS (CONT.)

TK11550

$T_A = 25\text{ }^\circ\text{C}$ unless otherwise specified

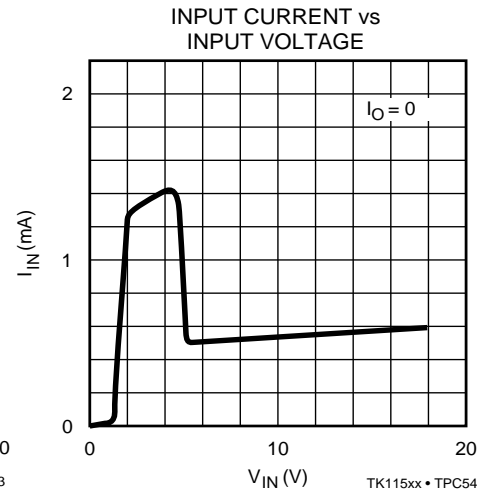
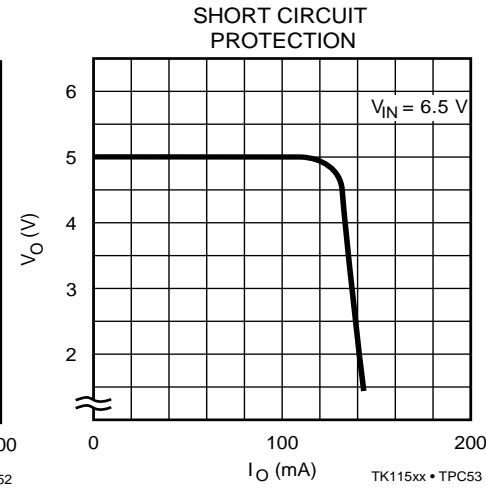
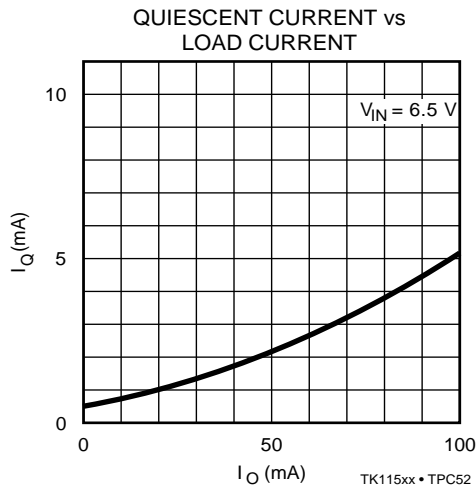
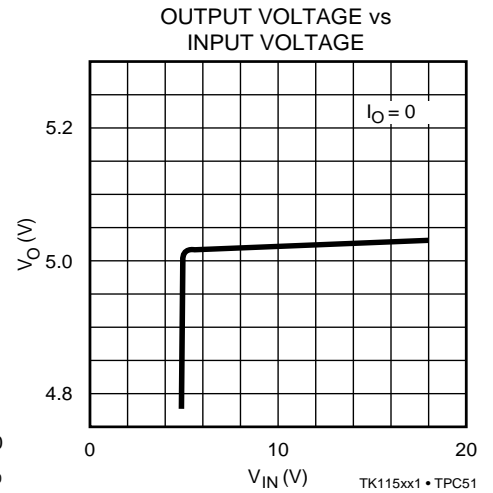
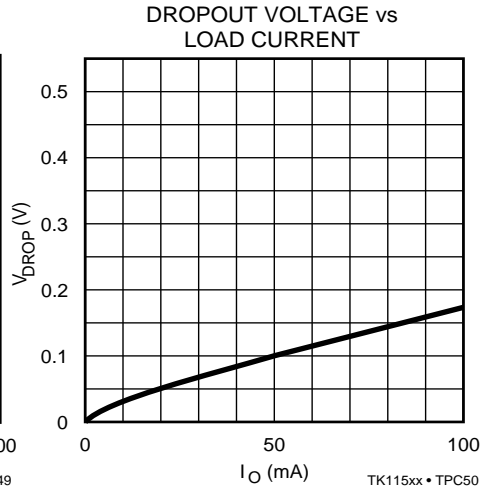
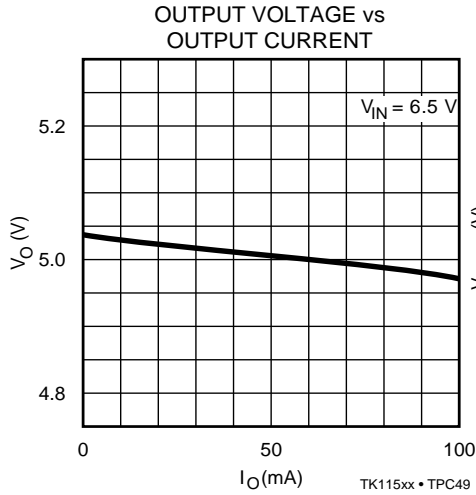

TK11555

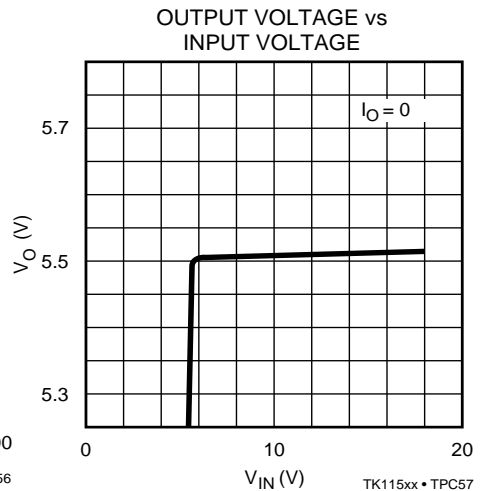
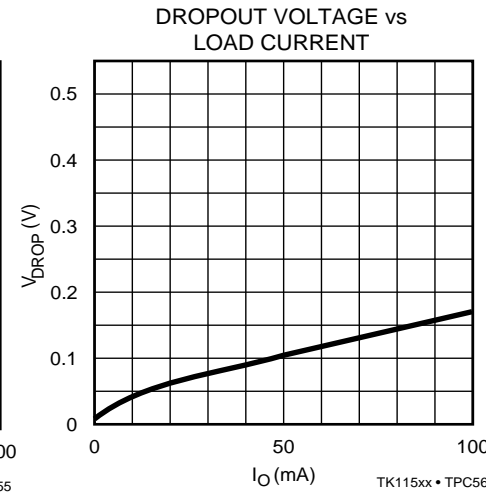
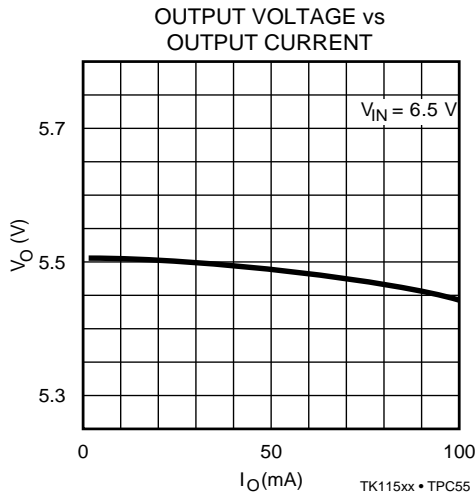

TYPICAL PERFORMANCE CHARACTERISTICS (CONT.)

TK11555 (CONT.)

$T_A = 25\text{ }^\circ\text{C}$ unless otherwise specified

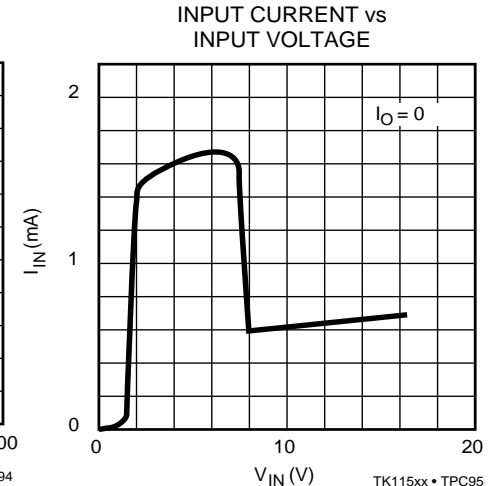
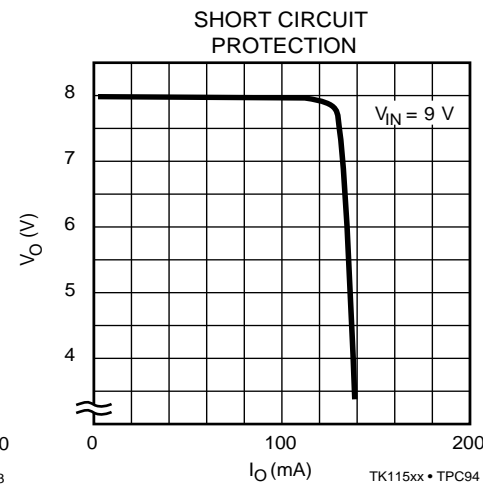
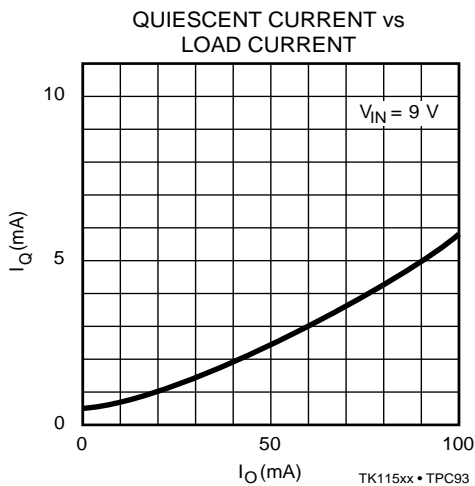
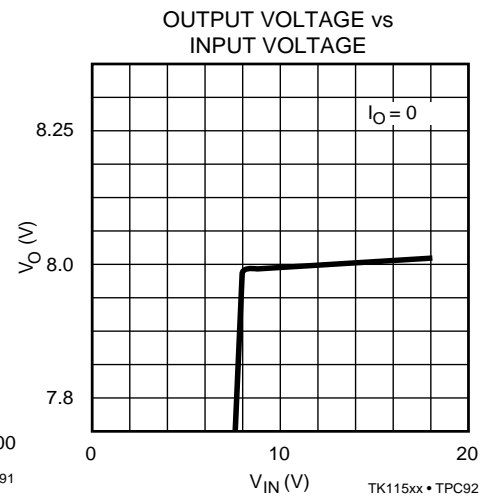
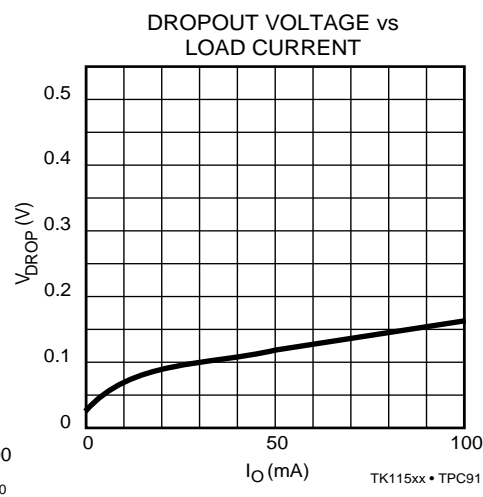
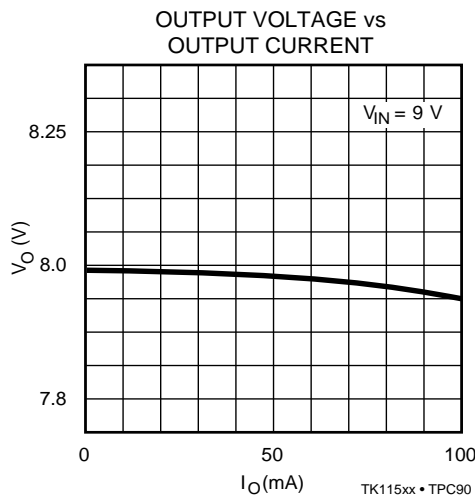
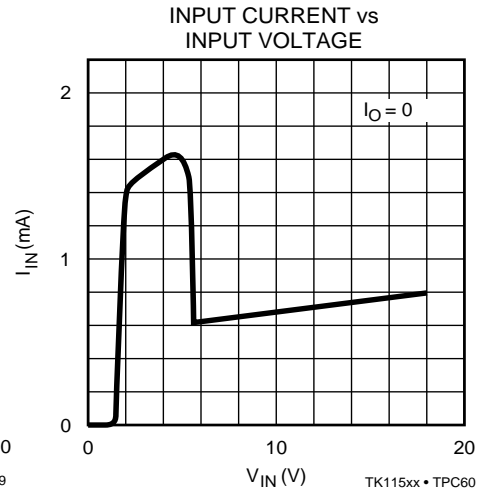
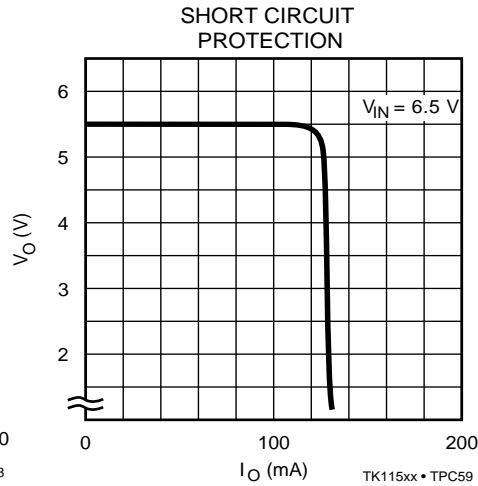
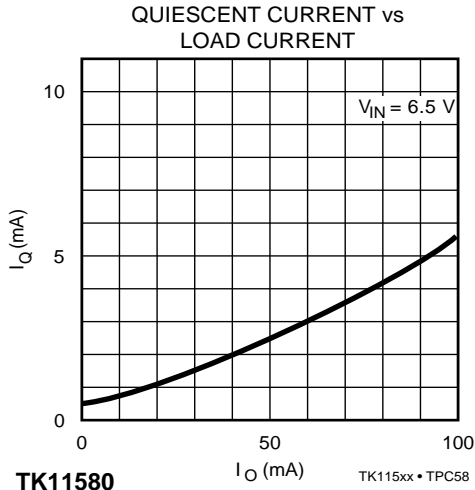

TYPICAL APPLICATIONS

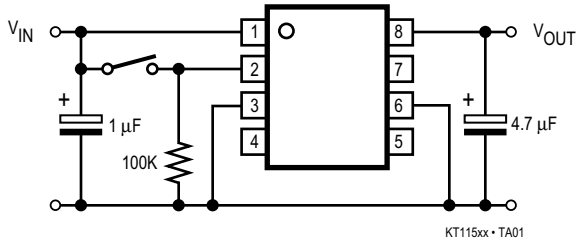

ACTIVE HIGH CONTROL

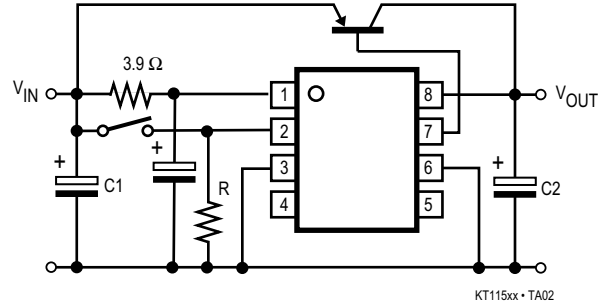

ACTIVE HIGH CONTROL WITH CURRENT BOOST

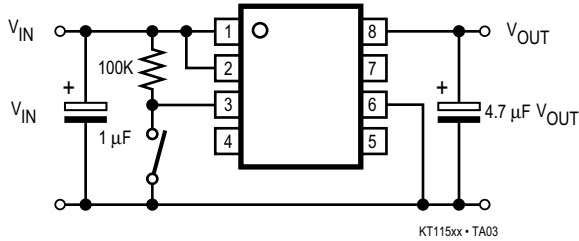

ACTIVE LOW CONTROL

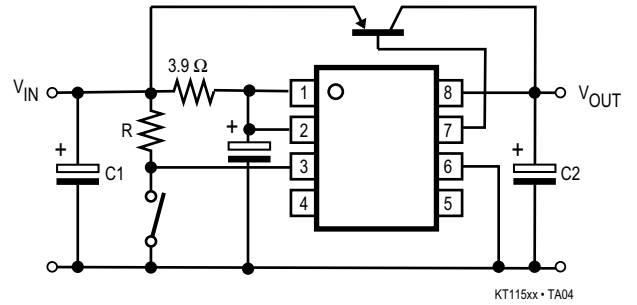

ACTIVE LOW CONTROL WITH CURRENT BOOST

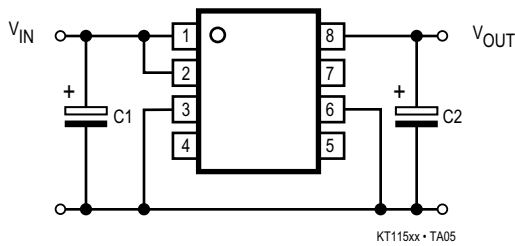

NO SWITCH CONTROL

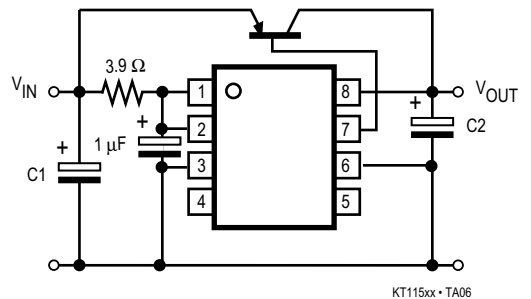

NO SWITCH CONTROL WITH CURRENT BOOST

TYPICAL APPLICATIONS (CONT.)

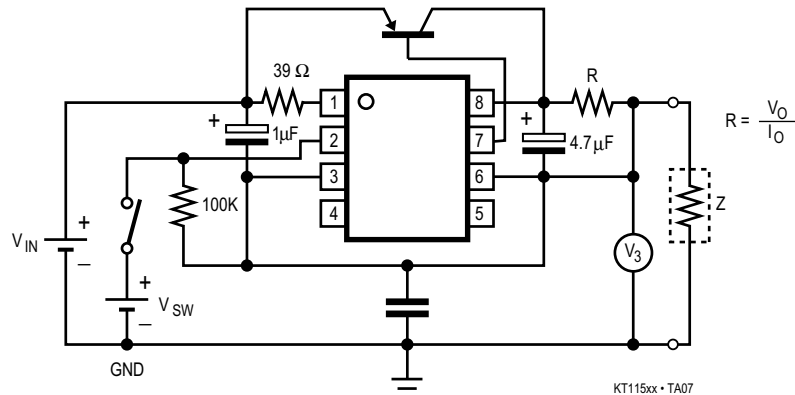

CURRENT MODE REGULATOR WITH ON/OFF CONTROL AND CURRENT BOOST

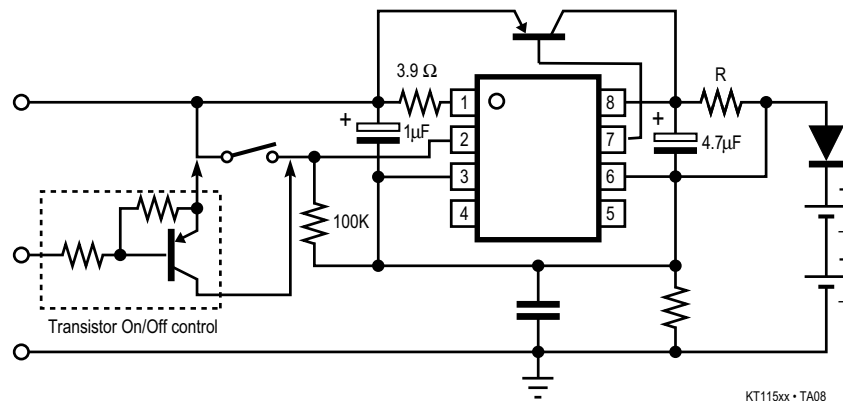

BATTERY CHARGER WITH ON/OFF CONTROL AND CURRENT BOOST

APPLICATION HINTS

Maximize copper foil area connecting to all IC pins for optimum performance. Place input and output bypass capacitors close to the GND pin. For best transient behavior and lowest output impedance, use as large a capacitor value as possible. The temperature coefficient of the capacitance and Equivalent Series Resistance

(ESR) should be taken into account. These parameters can influence power supply noise and ripple rejection. In extreme cases, oscillation may occur. In order to maintain stability, the output bypass capacitor value should be minimum 1 μF for Tantalum electrolytic or 4.7 μF for Aluminum electrolytic at $T_A = 25^\circ\text{C}$.

PACKAGE OUTLINE

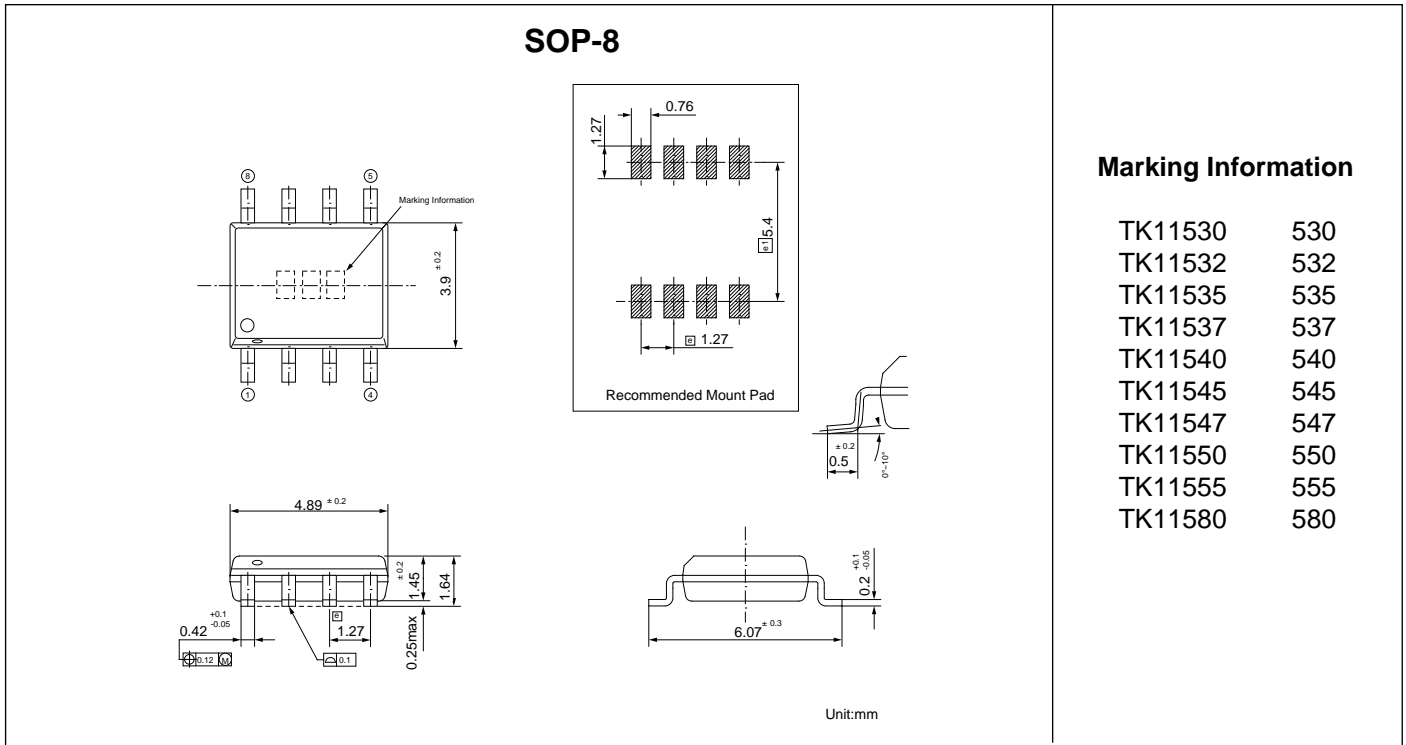

Marking Information

TK11530	530
TK11532	532
TK11535	535
TK11537	537
TK11540	540
TK11545	545
TK11547	547
TK11550	550
TK11555	555
TK11580	580

The information furnished by TOKO, Inc. is believed to be accurate and reliable. However, TOKO reserves the right to make changes or improvements in the design, specification or manufacture of its products without further notice. TOKO does not assume any liability arising from the application or use of any product or circuit described herein, nor for any infringements of patents or other rights of third parties which may result from the use of its products. No license is granted by implication or otherwise under any patent or patent rights of TOKO, Inc.



YOUR LOCAL REPRESENTATIVE IS:

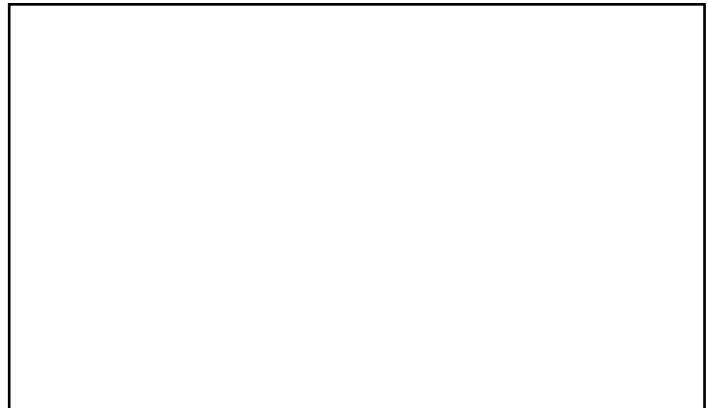

TOKO, Inc.
 1-17, Higashi-yukigaya 2-chome
 Ohta-ku, Tokyo
 145 Japan
 Tel: (03) 3727-1161
 Fax: (03) 3728-4690, 4697