

Filtered Modular Jacks - PCRJ Series

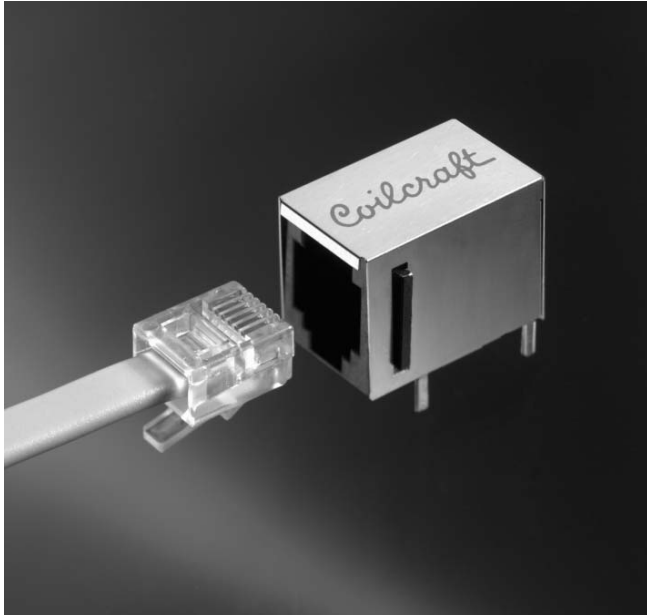

This product is not RoHS-compliant. Contact Coilcraft for current status or possible alternatives.

These filtered jacks virtually eliminate conducted and radiated noise in voice or data lines. And they suppress noise at the best possible spot for incoming and outgoing signals.

Available in RJ-45, -14 and -11 versions, they use a single high impedance magnetic structure to filter multiple signal lines simultaneously, providing common mode noise reduction without affecting the desired signal — something ferrite beads or sleeves can't achieve.

The -1 series jacks reduce common mode noise by 45 dB at 100 MHz while passing signals up to 48 MHz without attenuation; the -2 versions provide 20 dB attenuation at 100 MHz and pass differential mode signals up to 140 MHz.

The jacks come standard with a solderable shield and match standard industry footprints. Custom models are available to meet specific response characteristics.

Specifications

Part number	Number of positions	Number of contacts loaded	Current max (mA)	Schematic
PCRJ11-1	6	2	500	A
PCRJ14-1	6	4	500	B
PCRJ11-2	6	2	500	A
PCRJ14-2	6	4	500	C
PCRJ454-2	8	4	500	D
PCRJ458-1	8	8	500	E
PCRJ458-2	8	8	500	E

1. Operating temperature range -40°C to +85°C
2. Electrical specifications at 25°C

PCRJ11 and 14

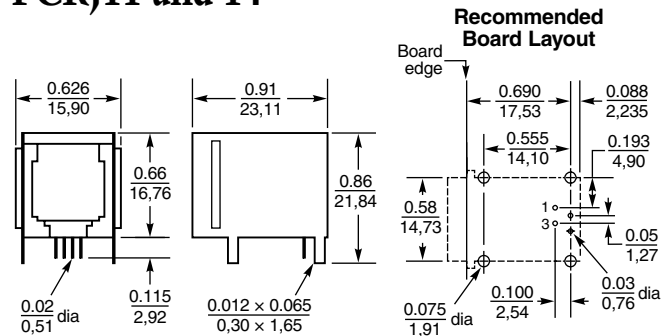

Schematics

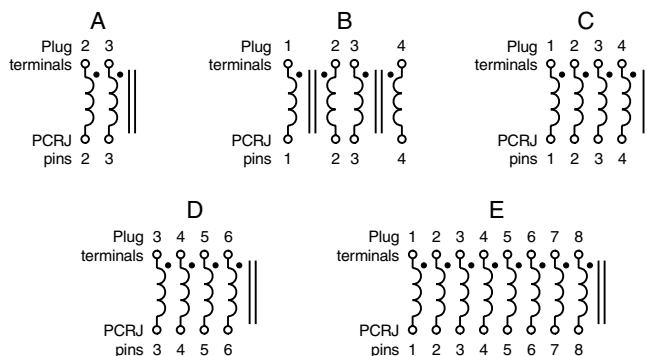

PCRJ454 and 458

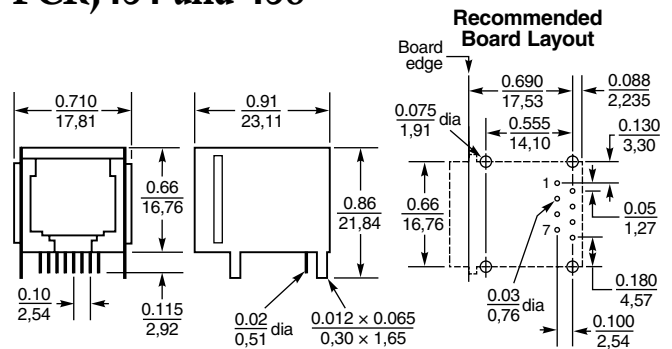

Specifications subject to change without notice. Please check our website for latest information. Document 189-1 Revised 04/07/09

1102 Silver Lake Road Cary, Illinois 60013 Phone 847/639-6400 Fax 847/639-1469
E-mail info@coilcraft.com Web <http://www.coilcraft.com>

-1 Series Performance

Typical Attenuation*

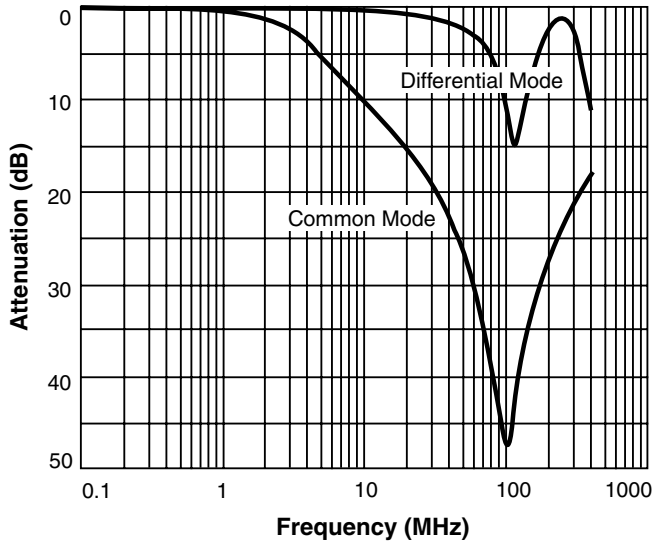

Typical Impedance vs Frequency

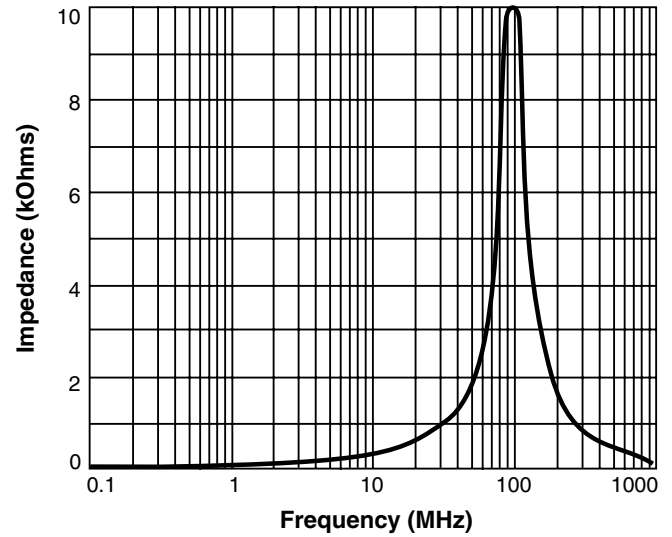

-2 Series Performance

Typical Attenuation*

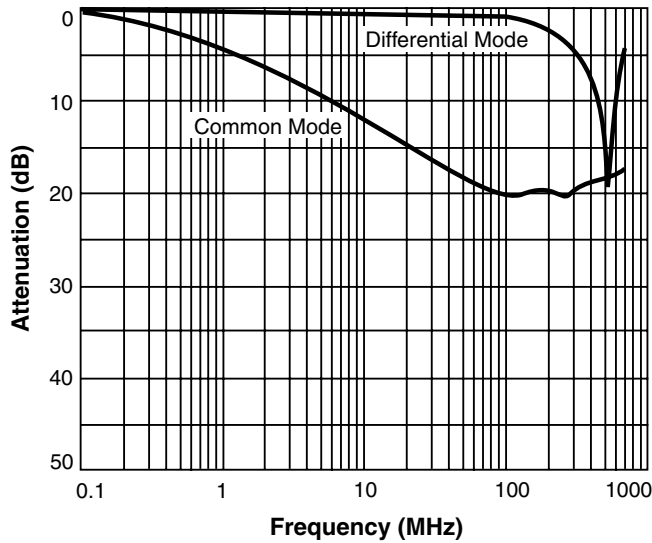

Typical Impedance vs Frequency

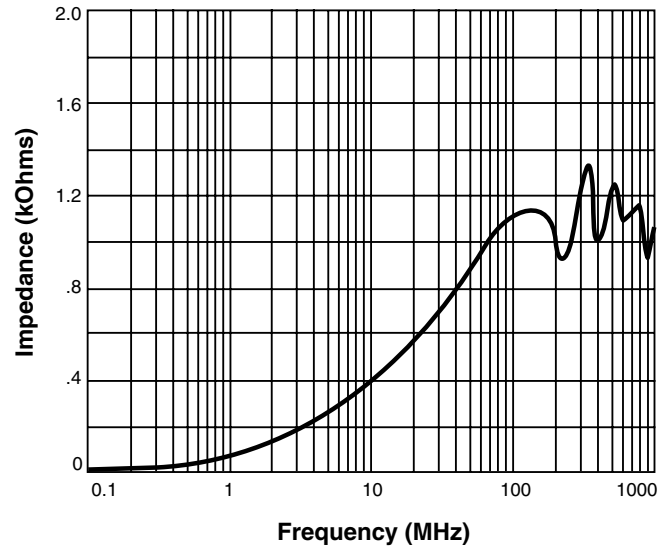

*measured on Agilent/HP8753D network analyzer. Ref: 50 Ohms.



Specifications subject to change without notice.
Please check our website for latest information. Document 189-2 Revised 04/07/09

1102 Silver Lake Road Cary, Illinois 60013 Phone 847/639-6400 Fax 847/639-1469
E-mail info@coilcraft.com Web http://www.coilcraft.com