

### DESCRIPTION

The EV0035 is the evaluation board for the MP1523, which is designed for driving up to six (6) series WLEDs from a single cell Lithium Ion battery. The board is set up to obtain 20mA LED current. The current can be adjusted by varying the resistor R2.

The MP1523 uses current limited, variable frequency architecture to regulate the LED current while maintaining high efficiency. The BIAS pin measures the output voltage and turns off the converter if an over voltage condition is present to prevent damage due to an open circuit condition. The LED current is measured with an external current sense resistor. The low 0.4V full-scale regulation threshold and 0.5Ω power switch minimize power loss to improve efficiency.

### ELECTRICAL SPECIFICATIONS

Parameter	Symbol	Value	Units
Input Voltage	$V_{IN}$	2.7 – 25	V
# of WLEDs		up to 6	
LED Current	$I_{LED}$	20	mA

### FEATURES

- 2.7V to 25V Input Voltage Range
- Drives up to 6 Series White LEDs
- Surface-Mount Components
- Fully Assembled and Tested

### APPLICATIONS

- Cell Phones
- Handheld Computers and PDAs
- Digital Still and Video Cameras
- Small LCD Displays

"MPS" and "The Future of Analog IC Technology" are Trademarks of Monolithic Power Systems, Inc.

### EV0035 EVALUATION BOARD



(L x W x H) 2.0" x 1.4" x 0.5"  
(5.0cm x 3.5 x 1.2cm)

Board Number	MPS IC Number
EV0035	MP1523DT

Efficiency vs  $V_{IN}$

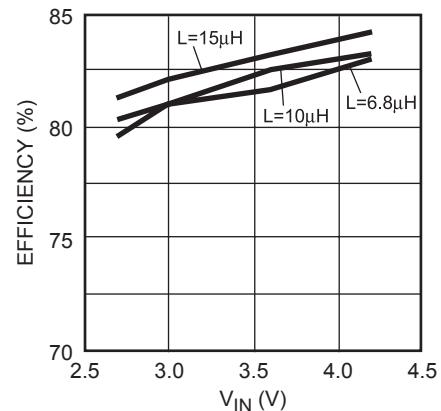

EV0035\_AC01

## EVALUATION BOARD SCHEMATIC

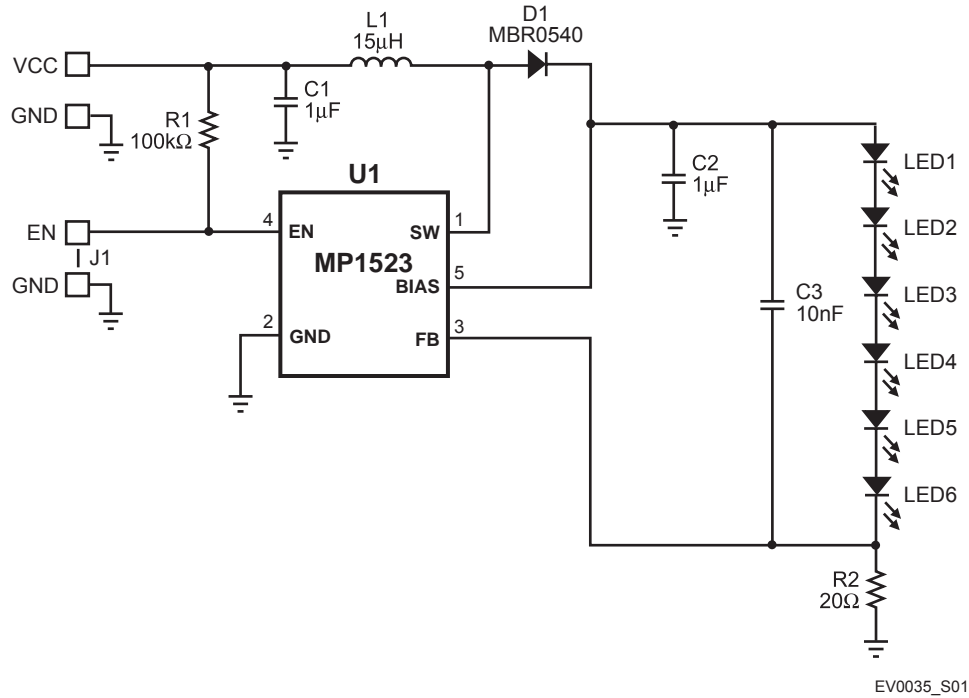

## EV0035 BILL OF MATERIALS

Qty	Ref	Value	Description	Package	Manufacturer	Part Number
2	C1, C2	1μF	Ceramic Cap., 50V, X7R	1206	TDK	C3216X7R1H105K
1	C3	10nF	Ceramic Cap., 50V, X7R	0603	TDK	C1608X7R1H103K
1	D1		Diode Schottky, 40V, 500mA	SOD-123	ON Semiconductor	MBR0540T1
6	LED1 to LED6		Not Stuffed			
1	L1	15μH	Inductor, 450mA	SMD	Sumida	CDRH3D16-150NC
1	R1	100kΩ	Film Res., 5%	0603	Panasonic	ERJ-3GEYJ104V
1	R2	20Ω	Film Res., 5%	0603	Panasonic	ERJ-3GEYJ200V
1	U1		White LED Driver	SOT23-5	MPS	MP1523DT

## PRINTED CIRCUIT BOARD LAYOUT

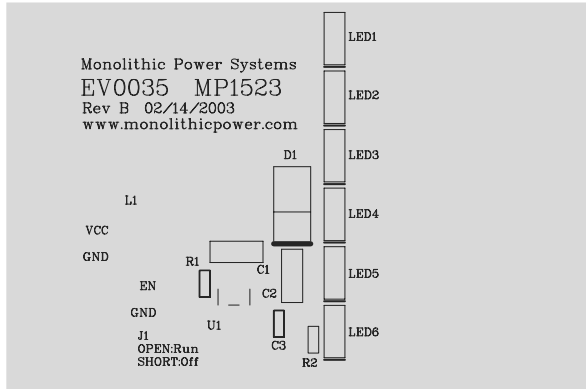

Figure 1—Top Silk Layer

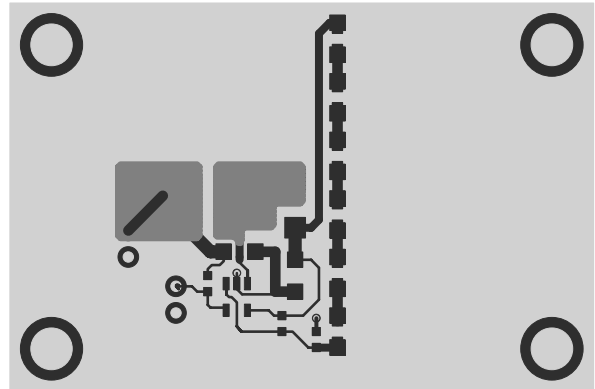

Figure 2—Top Layer



Figure 3—Bottom Layer

## QUICK START GUIDE

1. Solder LED1 – LED6 onto the board.
2. Connect VCC to the power source's positive output.
3. Connect GND to supply ground.
4. Remove the jumper J1 to allow the MP1523 to automatically start when power is applied. Place the shorting clip across J1 to disable the MP1523. A logic signal may be applied to EN to enable/disable the MP1523, provided the shorting clip is not installed across J1.
5. To dim the LEDs, remove the shorting clip from J1 and apply a PWM signal to the EN pin. Adjusting the duty cycle of the PWM signal determines the brightness of the LEDs.

**NOTICE:** The information in this document is subject to change without notice. Please contact MPS for current specifications. Users should warrant and guarantee that third party Intellectual Property rights are not infringed upon when integrating MPS products into any application. MPS will not assume any legal responsibility for any said applications.