

FEATURES

- Ultra-low Noise for RF Application
- Ultra-Fast Response in Line/Load Transient
- $0.01\mu\text{A}$ Standby Current When Shutdown.
- Low Dropout: 210mV@300mA
- Wide Operating Voltage Ranges: 2V to 6V
- TTL-logic-Controlled Shutdown Input
- Low Temperature Coefficient
- Current Limiting Protection
- Thermal Shutdown Protection
- Only 1 μF Output Capacitor Required for Stability
- High Power Supply Rejection Ratio
- Custom Voltage Available
- Fast output discharge
- Available in 5-Lead SOT-23 and SC-70 Package

- Hand-Held Instruments
- PCMCIA Cards
- MP3/MP4/MP5 Players
- Portable Information Appliances

DESCRIPTION

The BL9198 is designed for portable RF and wireless applications with demanding performance and space requirements. The BL9198 performance is optimized for battery-powered systems to deliver ultra low noise and low quiescent current. Regulator ground current increases only slightly in dropout, further prolonging the battery life. The BL9198 also works with low-ESR ceramic capacitors, reducing the amount of board space necessary for power applications, critical in hand-held wireless devices. The BL9198 consumes less than 0.01 μA in shutdown mode and has fast turn-on time less than 50 μs . The other features include ultra low dropout voltage, high output accuracy, current limiting protection, and high ripple rejection ratio. Available in the 5-lead SC-70 and SOT-23 packages.

APPLICATIONS

- Cellular and Smart Phones
- Battery-Powered Equipment
- Laptop, Palmtops, Notebook Computers

ORDERING INFORMATION

BL9198 XX X X XXX

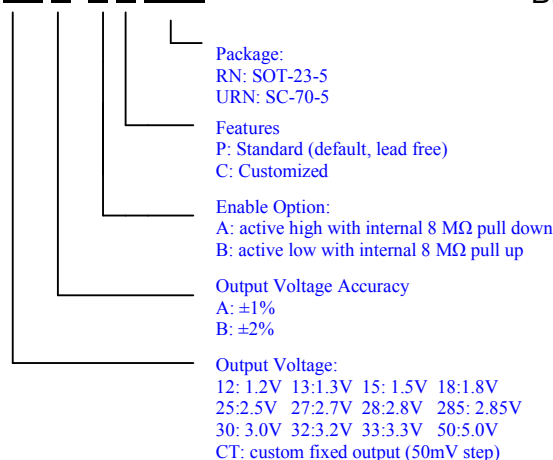

TYPICAL APPLICATION

BL9198 28 AA

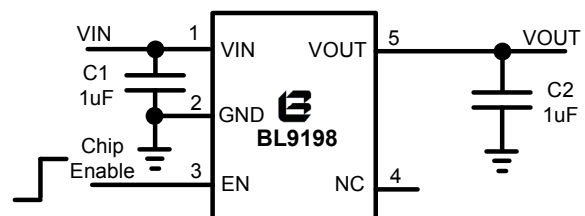

Application hints:

Output capacitor ($C2 \geq 2.2\mu\text{F}$) is recommended in BL9198-1.2V, BL9198-1.3V, BL9198-1.5V and BL9198-1.8V application to assure the stability of circuit.

Absolute Maximum Rating (Note 1)

Input Supply Voltage (VIN)	-0.3V to +6V	Maximum Junction Temperature	150°C
EN Pin Input Voltage	-0.3V to VIN	Operating Temperature Range <small>(Note2)</small>	-40°C to 85°C
Output Voltages	-0.3V to VIN+0.3V	Storage Temperature Range	-65°C to 125°C
Output Current	300mA	Lead Temperature (Soldering, 10s)	300°C

Package Information

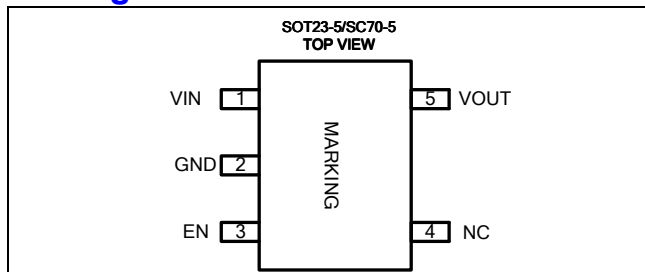

Part Number	Top Mark	Temp Range
BL9198-12	D A Y W <small>(Note3)</small>	-40°C to +85°C
BL9198-13	D B Y W	-40°C to +85°C
BL9198-15	D C Y W	-40°C to +85°C
BL9198-18	D D Y W	-40°C to +85°C
BL9198-25	D E Y W	-40°C to +85°C
BL9198-27	D F Y W	-40°C to +85°C
BL9198-28	D G Y W	-40°C to +85°C
BL9198-285	D H Y W	-40°C to +85°C
BL9198-30	D I Y W	-40°C to +85°C
BL9198-32	D J Y W	-40°C to +85°C
BL9198-33	D K Y W	-40°C to +85°C
BL9198-50	D L Y W	-40°C to +85°C

Thermal Resistance (Note 4):

Package	Θ_{JA}	Θ_{JC}
SOT23-5	250°C/W	130°C/W
SC70-5	333°C/W	170°C/W

A	B	C	D	E	F	G	H	I	J	K	L
1.2V	1.3V	1.5V	1.8V	2.5V	2.7V	2.8V	2.85V	3.0V	3.2V	3.3V	5.0V

Y	9	A	B	C	D
Year	2009	2010	2011	2012	2013

W	A	...	Y	Z	a	...	y	z
Week	1	...	25	26	27	...	51	52

Note 1: Absolute Maximum Ratings are those values beyond which the life of a device may be impaired.

Note 2: The BL9198 is guaranteed to meet performance specifications from 0°C to 70°C. Specifications over the -40°C to 85°C operating temperature range are assured by design, characterization and correlation with statistical process controls.

Note 3: D: Product code of BL9198 A-L; Voltage code Y; Year of wafer manufacturing W; Week of wafer manufacturing.

Note 4: Thermal Resistance is specified with approximately 1 square of 1 oz copper.

Pin Description

PIN	NAME	FUNCTION
1	VIN	Power Input Voltage.
2	GND	Ground.
3	EN	Chip Enable Pin with two options. A: active high with internal 8 MΩ pull down B: active low with internal 8 MΩ pull up
4	NC	No Connection.
5	VOUT	Output Voltage.

Block Diagram

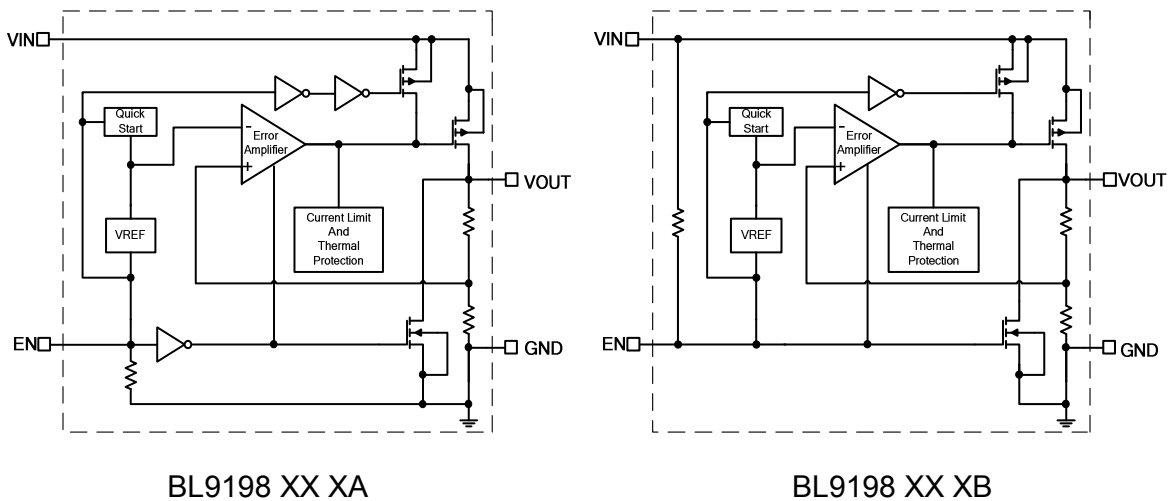

Electrical Characteristics (Note 5)

($V_{IN}=3.6V$, $V_{EN}=V_{IN}$, $C_{IN}=C_{OUT}=1\mu F$, $T_A=25^\circ C$, unless otherwise noted.)

Parameter	Symbol	Conditions	MIN	TYP	MAX	unit
Input Voltage	V_{IN}		2		6	V
Output Voltage Accuracy (Note 6)	ΔV_{OUT}	$V_{IN}=3.6V$, $I_{OUT}=1mA$	-1 -2		+1 +2	%
Current Limit	I_{LIM}	$R_{LOAD}=1\Omega$	400	430		mA
Quiescent Current	I_Q	$V_{EN}>1.2V$, $I_{OUT}=0mA$		90	130	μA
Dropout Voltage	V_{DROP}	$I_{OUT}=200mA$, $V_{OUT}=2.8V$		130	180	mV
		$I_{OUT}=300mA$, $V_{OUT}=2.8V$		210	300	
Line Regulation (Note 7)	ΔV_{LINE}	$V_{IN}=3.6V$ to $5.5V$ $I_{OUT}=1mA$		0.05	0.17	%/V
Load Regulation (Note 8)	ΔV_{LOAD}	$1mA < I_{OUT} < 300mA$			2	%/A
Output Voltage Temperature Coefficient (Note 9)	TC_{VOUT}	$I_{OUT}=1mA$		± 60		ppm/ $^\circ C$
Standby Current	I_{STBY}	$V_{EN}=GND$, Shutdown		0.01	1	μA
EN Input Bias Current	I_{IBSD}	$V_{EN}=GND$ or V_{IN}			500	nA
EN Input Threshold	Logic Low	V_{IL}	$V_{IN}=3V$ to $5.5V$, Shutdown		0.4	V
	Logic High	V_{IH}	$V_{IN}=3V$ to $5.5V$, Start up	1.2		V
Output Noise Voltage	e_{NO}	10Hz to 100KHz, $I_{OUT}=200mA$		100		μV_{RMS}
Power Supply Rejection Ratio	f=217Hz	PSRR	$I_{OUT}=100mA$		-78	dB
	f=1KHz				-72	
	f=10KHz				-52	
Thermal Shutdown Temperature	T_{SD}	Shutdown, Temp increasing		165		$^\circ C$
Thermal Shutdown Hysteresis	T_{SDHY}			30		$^\circ C$

Note 5: 100% production test at +25 $^\circ C$. Specifications over the temperature range are guaranteed by design and characterization.

Note 6: This IC includes two kinds of output voltage accuracy versions. A: $\pm 1\%$, B: $\pm 2\%$.

Note 7: Line regulation is calculated by
$$\Delta V_{LINE} = \left(\frac{V_{OUT1} - V_{OUT2}}{\Delta V_{IN} \times V_{OUT(normal)}} \right) \times 100$$

Where V_{OUT1} is the output voltage when $V_{IN}=5.5V$, and V_{OUT2} is the output voltage when $V_{IN}=3.6V$, $\Delta V_{IN}=1.9V$. $V_{OUT(normal)}=2.8V$.

Note 8: Load regulation is calculated by
$$\Delta V_{LOAD} = \left(\frac{V_{OUT1} - V_{OUT2}}{\Delta I_{OUT} \times V_{OUT(normal)}} \right) \times 100$$

Where V_{OUT1} is the output voltage when $I_{OUT}=1mA$, and V_{OUT2} is the output voltage when $I_{OUT}=300mA$. $\Delta I_{OUT}=0.299A$, $V_{OUT(normal)}=2.8V$.

Note 9: The temperature coefficient is calculated by
$$TC_{VOUT} = \frac{\Delta V_{OUT}}{\Delta T \times V_{OUT}}$$

Typical Performance Characteristics

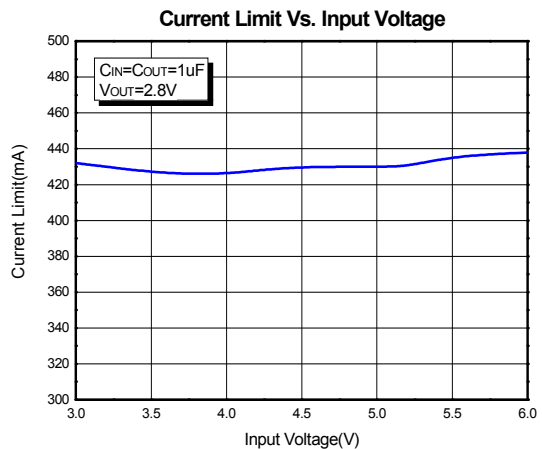
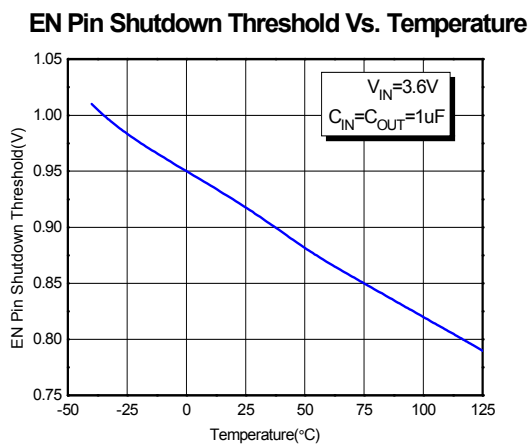
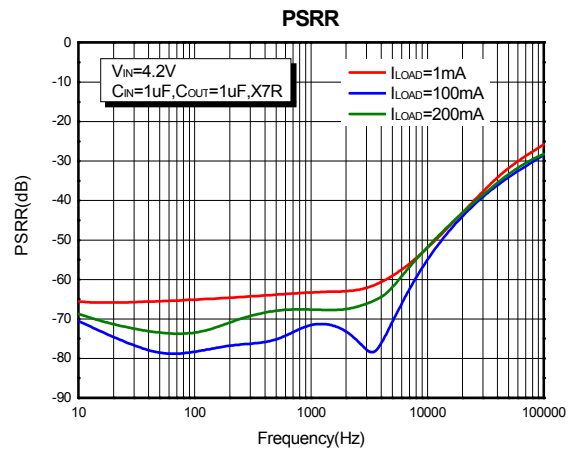
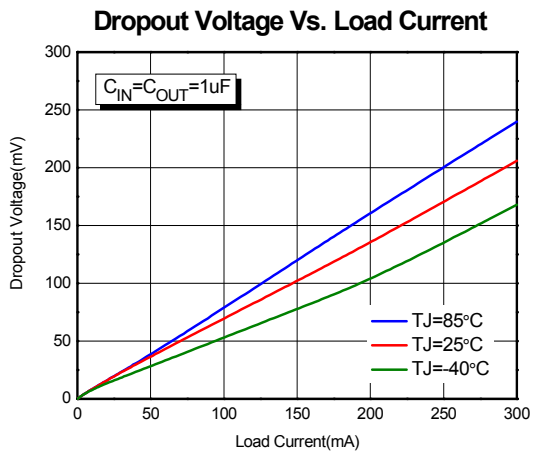
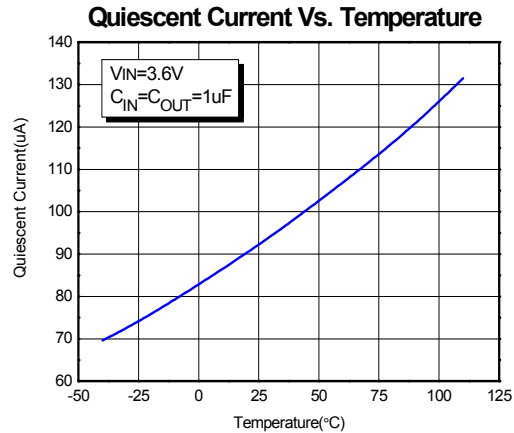
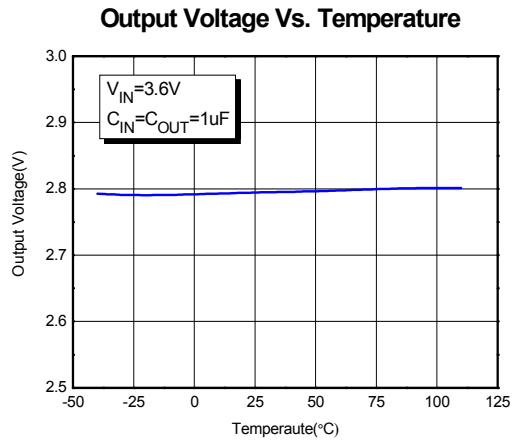

Load Transient Response

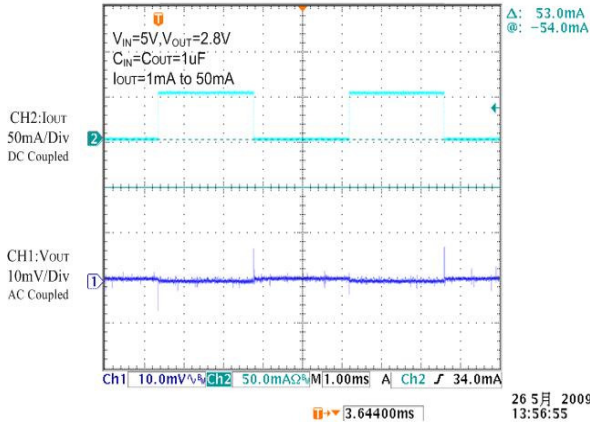

Load Transient Response

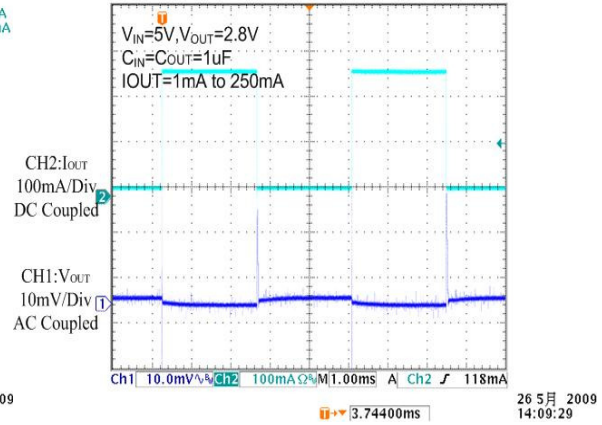

Line Transient Response

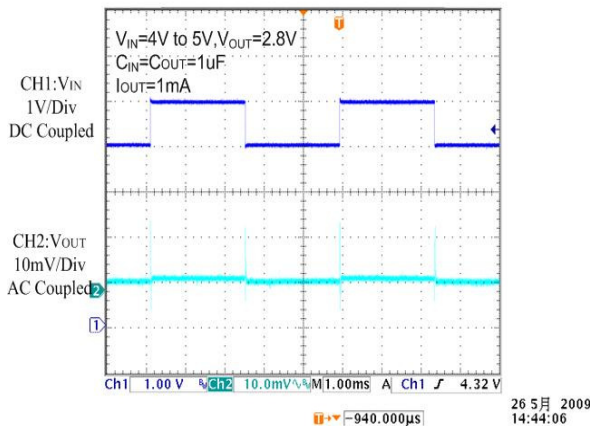

Line Transient Response

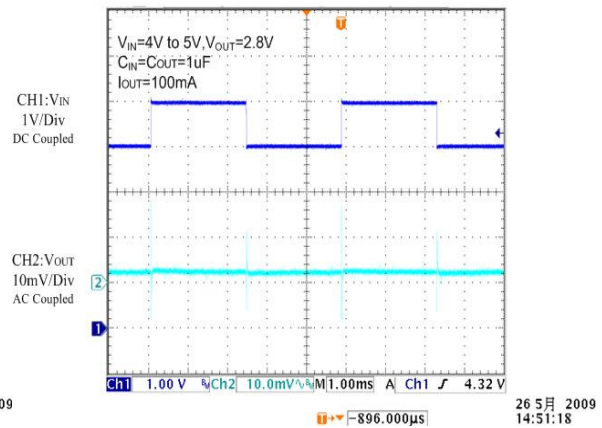

Start Up

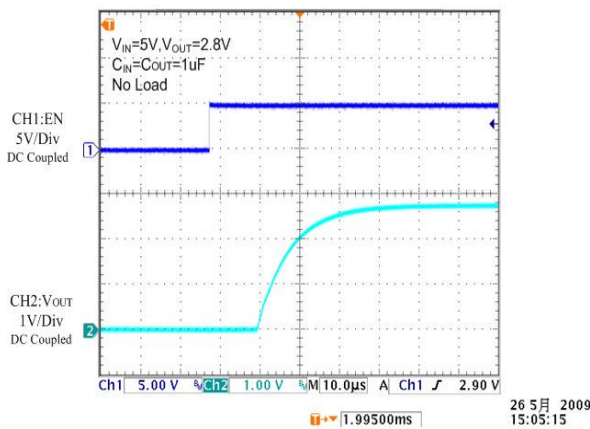

EN Pin Shutdown Response

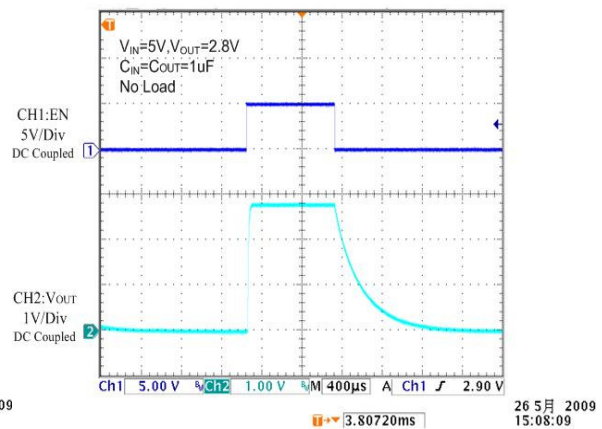

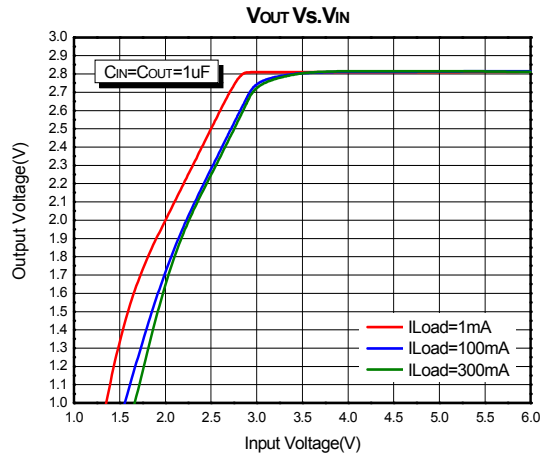

Applications Information

Like any low-dropout regulator, the external capacitors used with the BL9198 must be carefully selected for regulator stability and performance. Using a capacitor whose value is $> 1\mu\text{F}$ on the BL9198 input and the amount of capacitance can be increased without limit. The input capacitor must be located a distance of not more than 0.5 inch from the input pin of the IC and returned to a clean analog ground. Any good quality ceramic or tantalum can be used for this capacitor. The capacitor with larger value and lower ESR (equivalent series resistance) provides better PSRR and line-transient response. The output capacitor must meet both requirements for minimum amount of capacitance and ESR in all LDOs application. The BL9198 is designed specifically to work with low ESR ceramic output capacitor in space-saving and performance consideration. Using a ceramic capacitor whose value is at least $1\mu\text{F}$ with ESR is $> 25\text{m}\Omega$ on the BL9198 output ensures stability. The BL9198 still works well with output capacitor of other types due to the wide stable ESR range. Output capacitor of larger capacitance can reduce noise and improve load transient response, stability, and PSRR. The output capacitor should be located not more than 0.5 inch from the V_{OUT} pin of the BL9198 and returned to a clean analog ground.

Enable Function

The BL9198 features an LDO regulator enable/disable function. To assure the LDO regulator will switch on; the EN turn on control level must be greater than 1.2 volts. The LDO regulator will go into the shut-

down mode when the voltage on the EN pin falls below 0.4 volts. For to protect the system, the BL9198 have a quick discharge function. If the enable function is not needed in a specific application, it may be tied to V_{IN} to keep the LDO regulator in a continuously on state.

Thermal Considerations

Thermal protection limits power dissipation in BL9198. When the operation junction temperature exceeds 165°C , the OTP circuit starts the thermal shutdown function turn the pass element off. The pass element turns on again after the junction temperature cools by 30°C . For continue operation, do not exceed absolute maximum operation junction temperature 125°C . The power dissipation definition in device is:

$$P_{\text{D}}(\text{MAX}) = (T_{\text{J}}(\text{MAX}) - T_{\text{A}}) / \theta_{\text{JA}}$$

Where $T_{\text{J}}(\text{MAX})$ is the maximum operation junction temperature 125°C , T_{A} is the ambient temperature and the θ_{JA} is the junction to ambient thermal resistance. For recommended operating conditions specification of BL9198, where $T_{\text{J}}(\text{MAX})$ is the maximum junction temperature of the die (125°C) and T_{A} is the maximum ambient temperature. The junction to ambient thermal resistance (θ_{JA} is layout dependent) for SOT-23-5 package is $250^{\circ}\text{C}/\text{W}$, SC-70-5 package is $333^{\circ}\text{C}/\text{W}$, on standard JEDEC 51-3 thermal test board. The maximum power dissipation at $T_{\text{A}} = 25^{\circ}\text{C}$ can be calculated by following formula:

$$P_{\text{D}}(\text{MAX}) = (125^{\circ}\text{C} - 25^{\circ}\text{C}) / 333 = 300\text{mW} \text{ (SC-70-5)}$$

$$P_D(\text{MAX}) = (125^\circ\text{C} - 25^\circ\text{C}) / 250 = 400\text{mW} \quad (\text{SOT-23-5})$$

The maximum power dissipation depends on operating ambient temperature for fixed $T_J(\text{MAX})$ and thermal resistance θ_{JA} . It is also useful to calculate the junction of temperature of the BL9198 under a set of specific conditions. In this example let the Input voltage $V_{IN}=3.3\text{V}$, the output current $I_O=300\text{mA}$ and the case temperature $T_A=40^\circ\text{C}$ measured by a thermal couple during operation. The power dissipation for the $V_{OUT}=2.8\text{V}$ version of the BL9198 can be calculated as:

$$P_D = (3.3\text{V} - 2.8\text{V}) \times 300\text{mA} + 3.6\text{V} \times 100\mu\text{A} \\ = 150\text{mW}$$

And the junction temperature, T_J , can be calculated as follows:

$$T_J = T_A + P_D \times \theta_{JA} = 40^\circ\text{C} + 0.15\text{W} \times 250^\circ\text{C/W} \\ = 40^\circ\text{C} + 37.5^\circ\text{C} = 77.5^\circ\text{C} < T_J(\text{MAX}) = 125^\circ\text{C}$$

For this operating condition, T_J is lower than the absolute maximum operating junction temperature, 125°C , so it is safe to use the BL9198 in this configuration.

Layout considerations

To improve ac performance such as PSRR, output noise, and transient response, it is recommended that the PCB be designed with separate ground planes for V_{IN} and V_{OUT} , with each ground plane connected only at the GND pin of the device.

BL9198-2.8V Layout Circuit

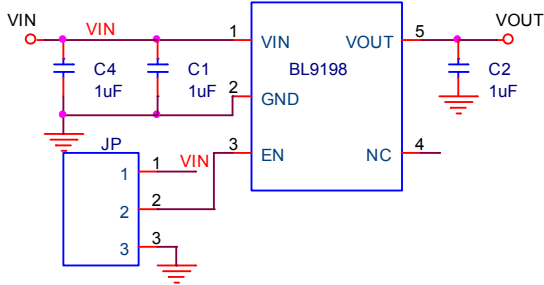

TOP Layer Layout

BOTTOM Layer Layout

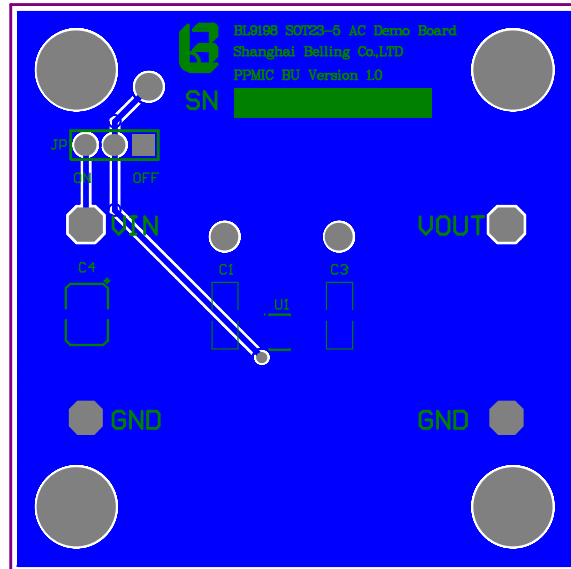
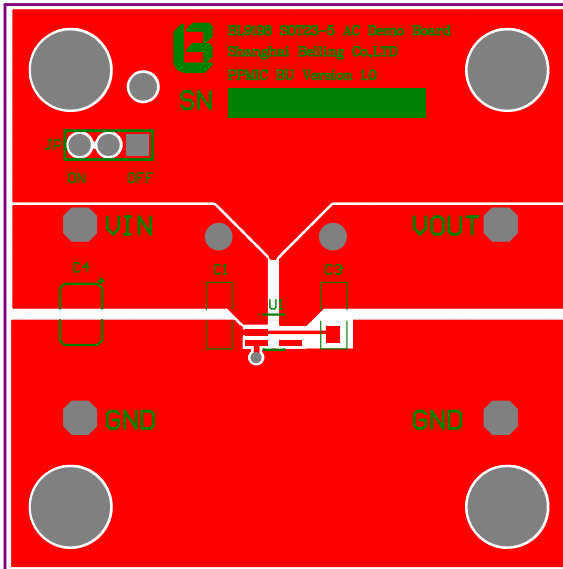

Package Description

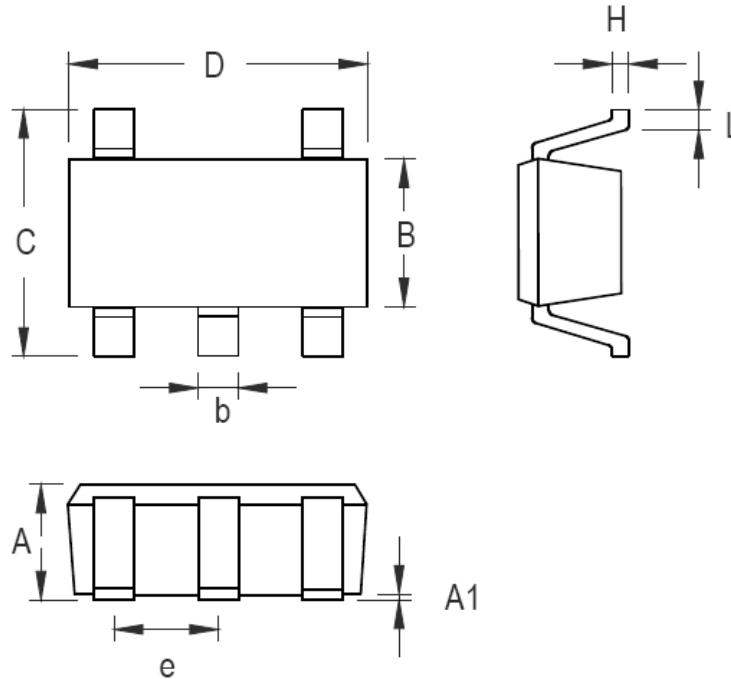

Symbol	Dimensions In Millimeters		Dimensions In Inches	
	Min	Max	Min	Max
A	0.800	1.100	0.031	0.044
A1	0.000	0.100	0.000	0.004
B	1.150	1.350	0.045	0.054
b	0.150	0.400	0.006	0.016
C	1.800	2.450	0.071	0.096
D	1.800	2.250	0.071	0.089
e	0.650		0.026	
H	0.080	0.260	0.003	0.010
L	0.210	0.460	0.008	0.018

SC-70-5 Surface Mount Package

Package type	SC70-5	Number of devices per reel	3000
Tape dimension			
Taping reel dimension			
Reel size			
Unit : mm (Inch)			

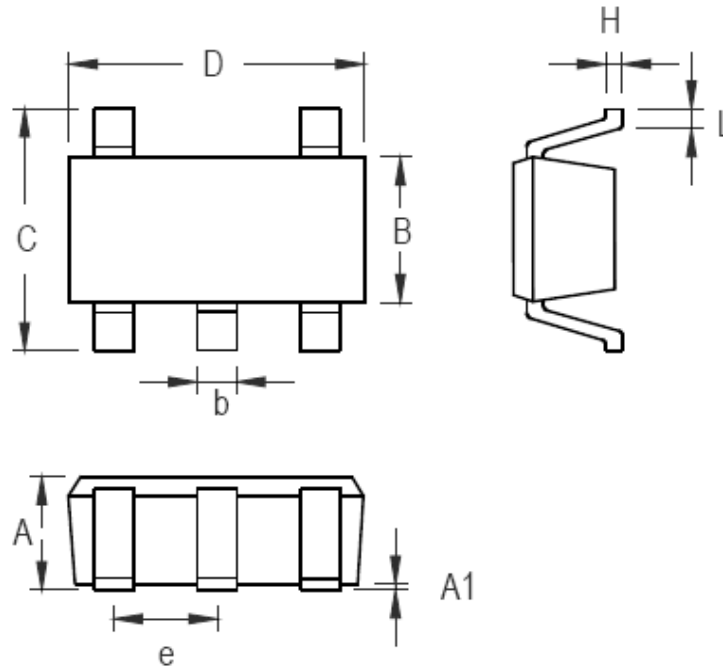

Symbol	Dimensions In Millimeters		Dimensions In Inches	
	Min	Max	Min	Max
A	0.889	1.295	0.035	0.051
A1	0.000	0.152	0.000	0.006
B	1.397	1.803	0.055	0.071
b	0.356	0.559	0.014	0.022
C	2.591	2.997	0.102	0.118
D	2.692	3.099	0.106	0.122
e	0.838	1.041	0.033	0.041
H	0.080	0.254	0.003	0.010
L	0.300	0.610	0.012	0.024

SOT-23-5 Surface Mount Package

