

PLEASE CHECK WWW.MOLEX.COM FOR LATEST PART INFORMATION

Part Number: [0503948200](#)
Status: **Active**
Overview: [milligrd](#)
Description: Milli-Grid™ Crimp Terminal, Bag, 0.76µm (30µ") Select Gold, Lead free

Documents:

[Drawing \(PDF\)](#) [RoHS Certificate of Compliance \(PDF\)](#)
[Product Specification PS-51110-001 \(PDF\)](#)

General

Product Family	Crimp Terminals
Series	50394
Crimp Quality Equipment	Yes
Overview	milligrd
Product Literature Order No	987650-1991
Product Name	Milli-Grid™

Physical

Gender	Female
Material - Metal	Phosphor Bronze
Material - Plating Mating	Gold
Material - Plating Termination	Nickel
Packaging Type	Bag
Plating min: Mating (µin)	30.4
Plating min: Mating (µm)	0.76
Plating min: Termination (µin)	80
Plating min: Termination (µm)	2
Termination Interface: Style	Crimp or Compression
Wire Insulation Diameter	1.40mm (.055") max.
Wire Size AWG	24, 26, 28, 30
Wire Size mm²	N/A

Material Info

Reference - Drawing Numbers

Product Specification	PS-51110-001
Sales Drawing	SD-50394-8***

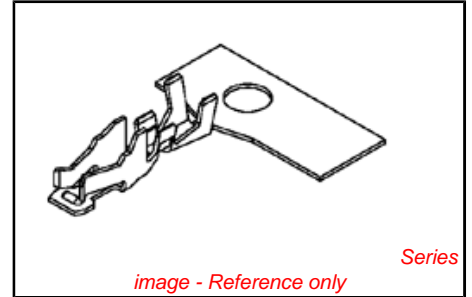

EU RoHS

ELV and RoHS Compliant
REACH SVHC
Contains SVHC: No
Halogen-Free Status
Halogen-Free

China RoHS



Need more information on product environmental compliance?

Email productcompliance@molex.com
 For a multiple part number RoHS Certificate of Compliance, [click here](#)

Please visit the [Contact Us](#) section for any non-product compliance questions.

Search Parts in this Series

[50394Series](#)

Use With

[51110 Crimp Housing](#)

Application Tooling | FAQ

Tooling specifications and manuals are found by selecting the products below. Crimp Height Specifications are then contained in the Application Tooling Specification document.

Global

Description	Product #
Hand Crimp Tool for Milli-Grid™ and MicroBlade Crimp Terminals	0638190100

PLEASE CHECK WWW.MOLEX.COM FOR LATEST PART INFORMATION

DWG. NO. SD 50394-8051
 CAD FILE S50394T.LDGN

DO NOT SCALE DRAWING

8 7 6 5 4 3 2 1

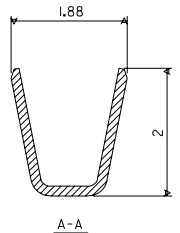
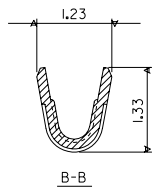
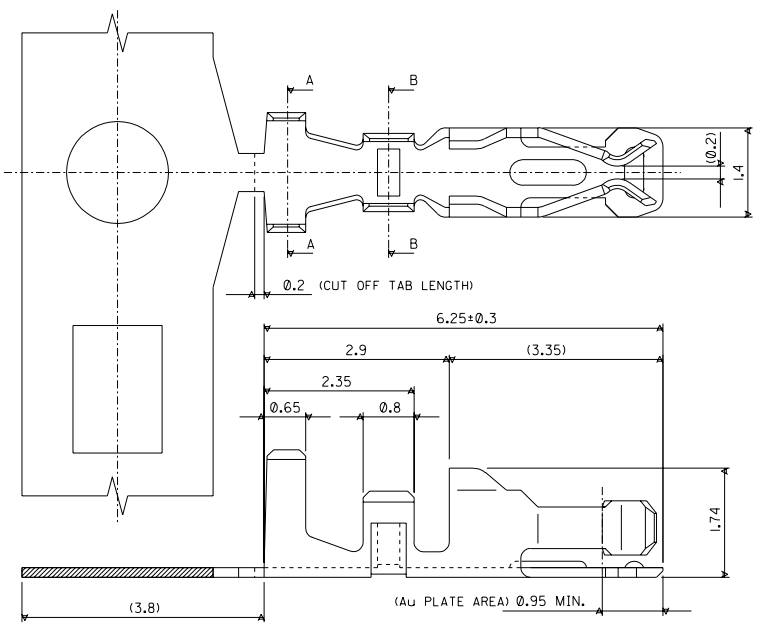

NOTES.

- 1. APPLICABLE HOUSING : 51110-***1
 : 51110-***5

GOLD FLASH 0.05-0.125 μm	50394-8400	50394-8054
0.38 Pd/Ni w/ GOLD FLASH	50394-8300	50394-8053
0.76	50394-8200	50394-8052
0.38	50394-8100	50394-8051
Au. PLATE THICK. (μm MIN.)	FORM:LOOSE	FORM:CHAIN
ENG.No.		

B	VOID PART NO. PER ECN S2004-0719	---	ANG- LNG	040223	MATERIAL : PHOSPHOR BRONZE (THK=0.152)	MOLEX SINGAPORE PTE LTD SHEET 1 OF 1
A2	ADD GOLD FLASH AS PER ECN*S2003-0030	---	NASH- LNG	02/07/12		
A1	ADD 0.38 Pd/Ni WITH GOLD FLASH AS PER PDR*98-01- 0267 (ECN*S1998-0364)	---	SEL- LNG	980312	FINISH : SEE NOTES	GENERAL TOLERANCES ± 0.20/.008 REV B
A	REL AS PER ECN*	S40519	SO- EDR	940420	DRAWN BY S.O. 940420	TITLE : 2.0mm GRID W TO B CONN. CRIMP TERMINAL
LTR	REVISION RECORD	ECN	DR- CHK	DATE		
REVISE ONLY ON CAD SYSTEM					APPR'D BY ROY 940428	SCALE 15:1

THIS DRAWING CONTAINS INFORMATION THAT IS PROPRIETARY TO MOLEX (S) PTE LTD AND SHOULD NOT BE USED WITHOUT WRITTEN PERMISSION