

**PLEASE CHECK WWW.MOLEX.COM FOR LATEST PART INFORMATION**

**Part Number:** **0190070028**  
**Status:** **Active**  
**Description:** Flag InsulKrimp™ Quick Disconnect, Female, for 14-16 (2.00-1.30) Wire, Metal Strip, Tab 6.35mm (.250") x 0.81mm (.0

**Documents:**

[Drawing \(PDF\)](#) [RoHS Certificate of Compliance \(PDF\)](#)  
[Product Specification PS-19902-008 \(PDF\)](#)

**Agency Certification**

CSA LR18689  
 UL E79133

**General**

Product Family Quick Disconnects  
 Series 19007  
 Crimp Quality Equipment Yes  
 Product Name InsulKrimp™  
 Type Quick Disconnect

**Physical**

Barrel Type Closed  
 Color - Resin Natural  
 Flammability 94V-0  
 Gender Female  
 Glow-Wire Compliant No  
 Insulation Nylon (PA)  
 Lock to Mating Part None  
 Material - Metal Brass  
 Material - Resin Nylon  
 Orientation Flag  
 Packaging Type Reel  
 Polarized to Mating Part No  
 Tab Thickness 0.81mm (.032")  
 Tab Width 6.35mm (.250")  
 Temperature Range - Operating -65°C to +105°C  
 Wire Insulation Diameter 5.08mm (.200") max.  
 Wire Size AWG 14, 16  
 Wire Size mm² 1.30 - 2.00

**Electrical**

Voltage - Maximum 600V

**Material Info**

Old Part Number BB-2221Z

**Reference - Drawing Numbers**

Product Specification PS-19902-008  
 Sales Drawing SD-19007-004

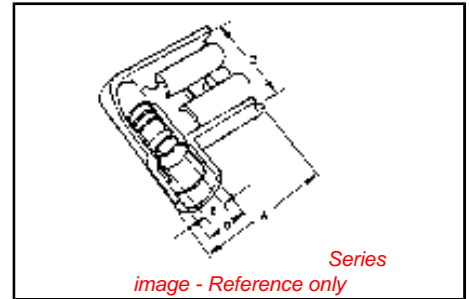

**EU RoHS**

**ELV and RoHS Compliant**  
**REACH SVHC Contains SVHC: No**  
**Halogen-Free Status Not Reviewed**

**China RoHS**



**Need more information on product environmental compliance?**

Email [productcompliance@molex.com](mailto:productcompliance@molex.com)  
 For a multiple part number RoHS Certificate of Compliance, [click here](#)

Please visit the [Contact Us](#) section for any non-product compliance questions.

**Search Parts in this Series**  
 19007Series

**Application Tooling | FAQ**

*Tooling specifications and manuals are found by selecting the products below. Crimp Height Specifications are then contained in the Application Tooling Specification document.*

**Global**

Description	Product #
Rear Feed Mini-Mac Applicator for Flag InsulKrimp™ Quick Disconnect Female Terminals, 14-16 AWG	0638026400
ASP Tool Kit, Perishable, Used in an ASP-101RF Press that Processes Metal Strip Product	0192870102

This document was generated on 04/12/2010

**PLEASE CHECK [WWW.MOLEX.COM](http://WWW.MOLEX.COM) FOR LATEST PART INFORMATION**

MATERIAL NUMBER	ENGINEERING NUMBER	CARRIER STYLE	AWG	COLOR	MWID	L	G	E	C	D (C)
190070001	AA-2220	LOOSE	22-18	RED	.176/4.47	.630/16.00	.585/14.86	.512/13.00	.236/5.99	.197/5.00
190070005	AA-2220X	LOOSE	22-18	RED	.240/6.10	.662/16.81	.625/15.88	.512/13.00	.300/7.26	.197/5.00
190070021	BB-2221	LOOSE	16-14	BLUE	.200/5.08	.630/16.00	.585/14.86	.500/12.70	.260/6.60	.197/5.00
190070025	BB-2221X	LOOSE	16-14	BLUE	.265/6.73	.670/17.02	.625/15.88	.500/12.70	.325/8.26	.197/5.00
190070040	C-2211	LOOSE	12-10	YELLOW	.260/6.60	.667/16.93	.677/17.20	.511/12.98	.311/7.90	.246/6.25
190070008	AA-2220Z	METAL STRIP	22-18	RED	.176/4.47	.630/16.00	.585/14.86	.512/13.00	.236/5.99	.197/5.00
190070007	AA-2220XZ	METAL STRIP	22-18	RED	.240/6.10	.662/16.81	.625/15.88	.512/13.00	.300/7.26	.197/5.00
190070028	BB-2221Z	METAL STRIP	16-14	BLUE	.200/5.08	.630/16.00	.585/14.86	.500/12.70	.260/6.60	.197/5.00
190070027	BB-2221XZ	METAL STRIP	16-14	BLUE	.265/6.73	.670/17.02	.625/15.88	.500/12.70	.325/8.26	.197/5.00
190070041	C-2211Z	METAL STRIP	12-10	YELLOW	.260/6.60	.667/16.93	.677/17.20	.511/12.98	.311/7.90	.246/6.25

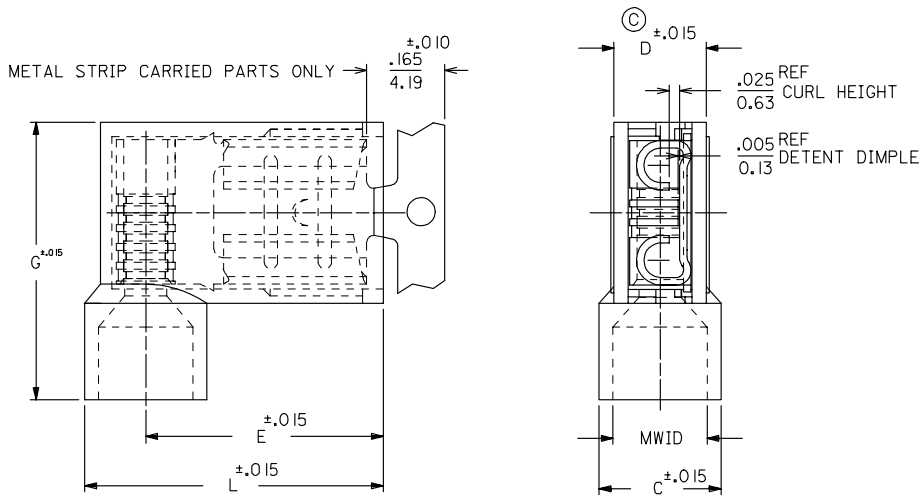

- NOTES:
- MWID = MAX. WIRE INSULATION DIA.
  - ALL DIMENSIONS = INCHES/MM
  - MATERIAL:  
HOUSING: NYLON  
TERMINAL: TIN PLATED BRASS
  - ASSEMBLY IS ROHS COMPLIANT.

REDWN W/DIM. D ADDED EC NO: ETC2007-0229 DRAWN/HILLE 2006/12/15 CHKD: JACNETL 2006/12/15 APPR: JACNETL 2006/12/15	QUALITY SYMBOLS	GENERAL TOLERANCES (UNLESS SPECIFIED)	DIMENSION STYLE IN/MM	SCALE 5:1	DESIGN UNITS INCH	THIRD ANGLE PROJECTION																										
	$\nabla=0$ $\sphericalangle=0$	<table border="1"> <tr> <th></th> <th>mm</th> <th>INCH</th> </tr> <tr> <td>4 PLACES</td> <td>± ---</td> <td>± ---</td> </tr> <tr> <td>3 PLACES</td> <td>± ---</td> <td>± .005</td> </tr> <tr> <td>2 PLACES</td> <td>± 0.13</td> <td>± .01</td> </tr> <tr> <td>1 PLACE</td> <td>± 0.25</td> <td>± ---</td> </tr> </table>		mm	INCH	4 PLACES	± ---	± ---	3 PLACES	± ---	± .005	2 PLACES	± 0.13	± .01	1 PLACE	± 0.25	± ---	<table border="1"> <tr> <th>DRAWN BY</th> <th>DATE</th> </tr> <tr> <td>RCM</td> <td>1989/07/26</td> </tr> <tr> <th>CHECKED BY</th> <th>DATE</th> </tr> <tr> <td>JM</td> <td>1989/07/26</td> </tr> <tr> <th>APPROVED BY</th> <th>DATE</th> </tr> <tr> <td>FP</td> <td>1989/07/26</td> </tr> </table>	DRAWN BY	DATE	RCM	1989/07/26	CHECKED BY	DATE	JM	1989/07/26	APPROVED BY	DATE	FP	1989/07/26	TITLE	FLAG QUICK DISCONNECT, FULLY INSULATED, .250 X .032 TAB SIZE
		mm	INCH																													
	4 PLACES	± ---	± ---																													
3 PLACES	± ---	± .005																														
2 PLACES	± 0.13	± .01																														
1 PLACE	± 0.25	± ---																														
DRAWN BY	DATE																															
RCM	1989/07/26																															
CHECKED BY	DATE																															
JM	1989/07/26																															
APPROVED BY	DATE																															
FP	1989/07/26																															
DRAFT WHERE APPLICABLE MUST REMAIN WITHIN DIMENSIONS	MATERIAL NO. SEE CHART	DOCUMENT NO. SD-19007-004	MOLEX INCORPORATED	SHEET NO. 1 OF 1																												