

# MAZ8000 Series

## Silicon planar type

For stabilization of power supply

### ■ Features

- Extremely low noise voltage caused from the diode (2.4V to 39V, 1/3 to 1/10 of our conventional MAZ3000 series)
- Extremely good rising performance (in the low-current range)
- Easy-to-select the optimum diode because of their finely divided zener-voltage ranks
- Guaranteed reliability, equivalent to that of conventional products (Mini type package)
- Allowing to reduce the mounting area, thickness and weight substantially, compared with those of the conventional products
- Allowing both reflow and flow mode of automatic soldering
- Allowing automatic mounting by an existing chip mounter

### ■ Absolute Maximum Ratings $T_a = 25^\circ\text{C}$

Parameter	Symbol	Rating	Unit
Repetitive peak forward current	$I_{FRM}$	200	mA
Total power dissipation*	$P_{tot}$	150	mW
Junction temperature	$T_j$	150	$^\circ\text{C}$
Storage temperature	$T_{stg}$	-55 to +150	$^\circ\text{C}$

Note) \* : With a printed-circuit board

### ■ Common Electrical Characteristics $T_a = 25^\circ\text{C}^{*1}$

Parameter	Symbol	Conditions	Min	Typ	Max	Unit
Forward voltage	$V_F$	$I_F = 10\text{ mA}$		0.9	1.0	V
Zener voltage <sup>*2</sup>	$V_Z$	$I_Z$ ..... Specified value				V
Operating resistance	$R_{ZK}$	$I_Z$ ..... Specified value	Refer to the list of the electrical characteristics within part numbers			$\Omega$
	$R_Z$	$I_Z$ ..... Specified value				$\Omega$
Reverse current	$I_R$	$V_R$ ..... Specified value				$\mu\text{A}$
Temperature coefficient of zener voltage <sup>*3</sup>	$S_Z$	$I_Z$ ..... Specified value				$\text{mV}/^\circ\text{C}$

Note) 1. Rated input/output frequency: 5 MHz

2. \*1 : The  $V_Z$  value is for the temperature of  $25^\circ\text{C}$ . In other cases, carry out the temperature compensation.

\*2 : Guaranteed at 20 ms after power application.

\*3 :  $T_j = 25^\circ\text{C}$  to  $150^\circ\text{C}$

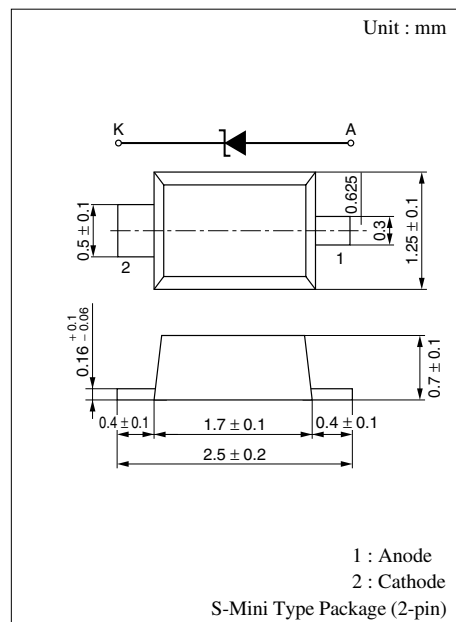

### Marking Symbol

Refer to the list of the electrical characteristics within part numbers

(Example) MAZ8082-H : 8<sup>^</sup>2

Note) L/M/H marked products will be supplied unless other wise specified

■ Electrical characteristics within part numbers  $T_a = 25^\circ\text{C}$

Part Number	Zener voltage				Reverse current		Operating resistance				Temperature coefficient of zener voltage		Marking Symbol	Conventional products
	$V_Z$ (V)				$I_R$ ( $\mu\text{A}$ )	$V_R$ (V)	$R_Z$ ( $\Omega$ )		$R_{ZK}$ ( $\Omega$ )		$S_Z$ (mV/ $^\circ\text{C}$ )			
	Min	Nom	Max	$I_Z$ (mA)			Max	$I_Z$ (mA)	Max	$I_Z$ (mA)	Typ	$I_Z$ (mA)		
MAZ8024	2.28	2.40	2.60	5	120	1.0	100	5	—	—	-1.6	5	2.4	MAZ3024
MAZ8027	2.50	2.70	2.90	5	120	1.0	110	5	—	—	-2.0	5	2_7or2^7	MAZ3027
MAZ8027-L	2.50	2.60	2.75										2_7	MAZ3027-L
MAZ8027-H	2.65	2.80	2.90										2^7	MAZ3027-H
MAZ8030	2.80	3.00	3.20	5	50	1.0	120	5	—	—	-2.1	5	3_0or3^0	MAZ3030
MAZ8030-L	2.80	2.90	3.05										3_0	MAZ3030-L
MAZ8030-H	2.95	3.10	3.20										3^0	MAZ3030-H
MAZ8033	3.10	3.30	3.50	5	20	1.0	130	5	—	—	-2.4	5	3_3or3^3	MAZ3033
MAZ8033-L	3.10	3.20	3.35										3_3	MAZ3033-L
MAZ8033-H	3.25	3.40	3.50										3^3	MAZ3033-H
MAZ8036	3.40	3.60	3.80	5	10	1.0	130	5	—	—	-2.4	5	3_6or3^6	MAZ3036
MAZ8036-L	3.40	3.50	3.65										3_6	MAZ3036-L
MAZ8036-H	3.55	3.70	3.80										3^6	MAZ3036-H
MAZ8039	3.70	3.90	4.10	5	10	1.0	130	5	—	—	-2.5	5	3_9or3^9	MAZ3039
MAZ8039-L	3.70	3.80	3.97										3_9	MAZ3039-L
MAZ8039-H	3.87	4.00	4.10										3^9	MAZ3039-H
MAZ8043	4.00	4.30	4.60	5	10	1.0	130	5	—	—	-2.5	5	4_3or4-3or4^3	MAZ3043
MAZ8043-L	4.03	4.10	4.26										4_3	MAZ3043-L
MAZ8043-M	4.17	4.30	4.40										4-3	MAZ3043-M
MAZ8043-H	4.31	4.40	4.54										4^3	MAZ3043-H
MAZ8047	4.40	4.70	5.00	5	2.0	1.0	80	5	800	1.0	-1.4	5	4_7or4-7or4^7	MAZ3047
MAZ8047-L	4.45	4.60	4.69										4_7	MAZ3047-L
MAZ8047-M	4.59	4.70	4.83										4-7	MAZ3047-M
MAZ8047-H	4.74	4.90	4.99										4^7	MAZ3047-H
MAZ8051	4.80	5.10	5.40	5	1.0	2.0	60	5	500	1.0	-0.8	5	5_1or5-1or5^1	MAZ3051
MAZ8051-L	4.87	5.00	5.12										5_1	MAZ3051-L
MAZ8051-M	5.00	5.10	5.26										5-1	MAZ3051-M
MAZ8051-H	5.14	5.30	5.40										5^1	MAZ3051-H
MAZ8056	5.30	5.60	6.00	5	0.5	2.5	40	5	200	0.5	1.2	5	5_6or5-6or5^6	MAZ3056
MAZ8056-L	5.30	5.40	5.58										5_6	MAZ3056-L
MAZ8056-M	5.48	5.60	5.76										5-6	MAZ3056-M
MAZ8056-H	5.66	5.80	5.95										5^6	MAZ3056-H
MAZ8062	5.80	6.20	6.60	5	0.2	4.0	30	5	100	0.5	2.3	5	6_2or6-2or6^2	MAZ3062
MAZ8062-L	5.85	6.00	6.15										6_2	MAZ3062-L
MAZ8062-M	6.05	6.20	6.36										6-2	MAZ3062-M
MAZ8062-H	6.24	6.40	6.56										6^2	MAZ3062-H
MAZ8068	6.40	6.80	7.20	5	0.1	4.0	20	5	60	0.5	3.0	5	6_8or6-8or6^8	MAZ3068
MAZ8068-L	6.44	6.60	6.77										6_8	MAZ3068-L
MAZ8068-M	6.64	6.80	6.98										6-8	MAZ3068-M
MAZ8068-H	6.85	7.00	7.20										6^8	MAZ3068-H
MAZ8075	7.00	7.50	7.90	5	0.1	5.0	20	5	60	0.5	4.0	5	7_5or7-5or7^5	MAZ3075
MAZ8075-L	7.07	7.30	7.43										7_5	MAZ3075-L
MAZ8075-M	7.29	7.50	7.67										7-5	MAZ3075-M
MAZ8075-H	7.51	7.70	7.89										7^5	MAZ3075-H
MAZ8082	7.70	8.20	8.70	5	0.1	5.0	20	5	60	0.5	4.6	5	8_2or8-2or8^2	MAZ3082
MAZ8082-L	7.77	7.90	8.17										8_2	MAZ3082-L
MAZ8082-M	8.03	8.20	8.43										8-2	MAZ3082-M
MAZ8082-H	8.29	8.50	8.70										8^2	MAZ3082-H

■ Electrical characteristics within part numbers (continued)  $T_a = 25^\circ\text{C}$ 

Part Number	Zener voltage			Reverse current			Operating resistance			Temperature coefficient of zener voltage		Marking Symbol	Conventional products										
	$V_Z$ (V)			$I_Z$ (mA)	$I_R$ ( $\mu\text{A}$ ) Max	$V_R$ (V)	$R_Z$ ( $\Omega$ ) Max	$I_Z$ (mA)	$R_{ZK}$ ( $\Omega$ ) Max	$I_Z$ (mA)	$S_Z$ (mV/ $^\circ\text{C}$ )												
	Min	Nom	Max								Typ			$I_Z$ (mA)									
MAZ8091	8.50	9.10	9.60	5	0.1	6.0	20	5	60	0.5	5.5	5	9_1or9-1or9^1	MAZ3091									
MAZ8091-L	8.58	8.80	9.02										9_1	MAZ3091-L									
MAZ8091-M	8.87	9.10	9.33										9-1	MAZ3091-M									
MAZ8091-H	9.14	9.40	9.60										9^1	MAZ3091-H									
MAZ8100	9.40	10.00	10.60	5	0.05	7.0	30	5	60	0.5	6.4	5	10_or10-or10^A	MAZ3100									
MAZ8100-L	9.44	9.70	9.92										10_	MAZ3100-L									
MAZ8100-M	9.75	10.00	10.25										10-	MAZ3100-M									
MAZ8100-H	10.07	10.30	10.59										10^A	MAZ3100-H									
MAZ8110	10.40	11.00	11.60	5	0.05	8.0	30	5	60	0.5	7.4	5	11_or11-or11^A	MAZ3110									
MAZ8110-L	10.40	10.70	10.94										11_	MAZ3110-L									
MAZ8110-M	10.73	11.00	11.28										11-	MAZ3110-M									
MAZ8110-H	11.05	11.30	11.60										11^A	MAZ3110-H									
MAZ8120	11.40	12.00	12.70	5	0.05	9.0	30	5	80	0.5	8.4	5	12_or12-or12^A	MAZ3120									
MAZ8120-L	11.40	11.70	11.96										12_	MAZ3120-L									
MAZ8120-M	11.73	12.00	12.33										12-	MAZ3120-M									
MAZ8120-H	12.06	12.30	12.68										12^A	MAZ3120-H									
MAZ8130	12.40	13.00	14.10	5	0.05	10.0	35	5	80	0.5	9.4	5	13_or13-or13^A	MAZ3130									
MAZ8130-L	12.40	12.70	12.99										13_	MAZ3130-L									
MAZ8130-M	12.73	13.00	13.40										13-	MAZ3130-M									
MAZ8130-H	13.25	13.70	14.08										13^A	MAZ3130-H									
MAZ8140-M	13.65	14.00	14.35	5	0.05	10.0	40	5	80	0.5	10.0	5	14-	MAZ3140-M									
MAZ8150	13.90	15.00	15.60										5	0.05	11.0	40	5	80	0.5	11.4	5	15_or15-or15^A	MAZ3150
MAZ8150-L	13.90	14.30	14.76																			15_	MAZ3150-L
MAZ8150-M	14.60	15.00	15.35																			15-	MAZ3150-M
MAZ8150-H	14.95	15.30	15.60	15^A	MAZ3150-H																		
MAZ8160	15.30	16.00	17.10	5	0.05	12.0	50	5	80	0.5	12.4	5	16_or16-or16^A	MAZ3160									
MAZ8160-L	15.30	15.70	16.09										16_	MAZ3160-L									
MAZ8160-M	15.70	16.00	16.50										16-	MAZ3160-M									
MAZ8160-H	16.26	16.70	17.10										16^A	MAZ3160-H									
MAZ8180	16.90	18.00	19.10	5	0.05	13.0	60	5	80	0.5	14.4	5	18_or18-or18^A	MAZ3180									
MAZ8180-L	16.90	17.30	17.76										18_	MAZ3180-L									
MAZ8180-M	17.55	18.00	18.45										18-	MAZ3180-M									
MAZ8180-H	18.20	18.70	19.10										18^A	MAZ3180-H									
MAZ8200	18.80	20.00	21.20	5	0.05	15.0	80	5	100	0.5	16.4	5	20_or20-or20^A	MAZ3200									
MAZ8200-L	18.85	19.30	19.81										20_	MAZ3200-L									
MAZ8200-M	19.50	20.00	20.50										20-	MAZ3200-M									
MAZ8200-H	20.15	20.70	21.19										20^A	MAZ3200-H									
MAZ8220	20.80	22.00	23.30	5	0.05	17.0	80	5	100	0.5	18.4	5	22_or22-or22^A	MAZ3220									
MAZ8220-L	20.80	21.30	21.86										22_	MAZ3220-L									
MAZ8220-M	21.45	22.00	22.55										22-	MAZ3220-M									
MAZ8220-H	22.10	22.70	23.24										22^A	MAZ3220-H									
MAZ8240	22.80	24.00	25.60	5	0.05	19.0	100	5	120	0.5	20.4	5	24_or24-or24^A	MAZ3240									
MAZ8240-L	22.80	23.30	23.97										24_	MAZ3240-L									
MAZ8240-M	23.50	24.00	24.70										24-	MAZ3240-M									
MAZ8240-H	24.35	25.00	25.60										24^A	MAZ3240-H									
MAZ8270	25.10	27.00	28.90	2	0.05	21.0	120	2	120	0.5	23.4	2	27_or27-or27^A	MAZ3270									
MAZ8270-L	25.30	26.00	26.70										27_	MAZ3270-L									
MAZ8270-M	26.30	27.00	27.70										27-	MAZ3270-M									
MAZ8270-H	27.30	28.00	28.70										27^A	MAZ3270-H									

■ Electrical characteristics within part numbers (continued)  $T_a = 25^\circ\text{C}$

Part Number	Zener voltage			Reverse current		Operating resistance				Temperature coefficient of zener voltage		Marking Symbol	Conventional products	
	$V_Z$ (V)			$I_R$ ( $\mu\text{A}$ )	$V_R$ (V)	$R_Z$ ( $\Omega$ )		$R_{ZK}$ ( $\Omega$ )		$S_Z$ (mV/ $^\circ\text{C}$ )				
	Min	Nom	Max			$I_Z$ (mA)	Max	$I_Z$ (mA)	Max	$I_Z$ (mA)	Typ			$I_Z$ (mA)
MAZ8300	28.00	30.00	32.00	2	0.05	23.0	160	2	160	0.5	26.6	2	30_or30-or30^	MAZ3300
MAZ8300-L	28.30	29.00	29.70										30_	MAZ3300-L
MAZ8300-M	29.30	30.00	30.80										30-	MAZ3300-M
MAZ8300-H	30.20	31.00	31.80										30^	MAZ3300-H
MAZ8330	31.00	33.00	35.00	2	0.05	25.0	200	2	200	0.5	29.7	2	33_or33-or33^	MAZ3330
MAZ8330-L	31.20	32.00	32.80										33_	MAZ3330-L
MAZ8330-M	32.20	33.00	33.80										33-	MAZ3330-M
MAZ8330-H	33.20	34.00	34.90										33^	MAZ3330-H
MAZ8360	34.00	36.00	38.00	2	0.05	27.0	250	2	250	0.5	33.0	2	36_or36-or36^	MAZ3360
MAZ8360-L	34.10	35.00	35.90										36_	MAZ3360-L
MAZ8360-M	35.10	36.00	36.90										36-	MAZ3360-M
MAZ8360-H	36.10	37.00	37.90										36^	MAZ3360-H
MAZ8390	37.00	39.00	41.00	2	0.05	30.0	300	2	300	0.5	35.6	2	39_or39-or39^	—
MAZ8390-L	37.10	38.00	39.00										39_	—
MAZ8390-M	38.00	39.00	40.00										39-	—
MAZ8390-H	39.00	40.00	41.00										39^	—

Note) 1. The  $V_Z$  value is the one after power application for 20 ms at  $T_a = 25^\circ\text{C}$ .  
 2. The zener voltage temperature coefficient is the one for  $T_j = 25^\circ\text{C}$  to  $150^\circ\text{C}$ .

