

512M bits DDR2 SDRAM**EDE5104AJSE (128M words × 4 bits)
EDE5108AJSE (64M words × 8 bits)
EDE5116AJSE (32M words × 16 bits)****Specifications**

- Density: 512M bits
- Organization
 - 32M words × 4 bits × 4 banks (EDE5104AJSE)
 - 16M words × 8 bits × 4 banks (EDE5108AJSE)
 - 8M words × 16 bits × 4 banks (EDE5116AJSE)
- Package
 - 60-ball FBGA (EDE5104/08AJSE)
 - 84-ball FBGA (EDE5116AJSE)
 - Lead-free (RoHS compliant)
- Power supply: VDD, VDDQ = 1.8V ± 0.1V
- Data rate: 800Mbps/667Mbps (max.)
- 1KB page size
 - Row address: A0 to A13
 - Column address: A0 to A9, A11 (EDE5104AJSE)
A0 to A9 (EDE5108AJSE)
- 2KB page size (EDE5116AJSE)
 - Row address: A0 to A12
 - Column address: A0 to A9
- Four internal banks for concurrent operation
- Interface: SSTL_18
- Burst lengths (BL): 4, 8
- Burst type (BT):
 - Sequential (4, 8)
 - Interleave (4, 8)
- /CAS Latency (CL): 3, 4, 5, 6
- Precharge: auto precharge option for each burst access
- Driver strength: normal/weak
- Refresh: auto-refresh, self-refresh
- Refresh cycles: 8192 cycles/64ms
 - Average refresh period
7.8μs at 0°C ≤ TC ≤ +85°C
3.9μs at +85°C < TC ≤ +95°C
- Operating case temperature range
 - TC = 0°C to +95°C

Features

- Double-data-rate architecture; two data transfers per clock cycle
- The high-speed data transfer is realized by the 4 bits prefetch pipelined architecture
- Bi-directional differential data strobe (DQS and /DQS) is transmitted/received with data for capturing data at the receiver
- DQS is edge-aligned with data for READs; center-aligned with data for WRITEs
- Differential clock inputs (CK and /CK)
- DLL aligns DQ and DQS transitions with CK transitions
- Commands entered on each positive CK edge; data and data mask referenced to both edges of DQS
- Data mask (DM) for write data
- Posted /CAS by programmable additive latency for better command and data bus efficiency
- Off-Chip-Driver Impedance Adjustment and On-Die-Termination for better signal quality
- Programmable RDQS, /RDQS output for making × 8 organization compatible to × 4 organization
- /DQS, (/RDQS) can be disabled for single-ended Data Strobe operation

Ordering Information

Part number	Mask version	Organization (words × bits)	Internal Banks	Speed bin (CL-tRCD-tRP)	Package
EDE5104AJSE-8E-E	J	128M × 4	4	DDR2-800 (5-5-5)	60-ball FBGA
EDE5104AJSE-6E-E				DDR2-667 (5-5-5)	
EDE5108AJSE-8E-E		64M × 8		DDR2-800 (5-5-5)	
EDE5108AJSE-6E-E				DDR2-667 (5-5-5)	
EDE5116AJSE-8E-E		32M × 16		DDR2-800 (5-5-5)	84-ball FBGA
EDE5116AJSE-6E-E				DDR2-667 (5-5-5)	

Part Number

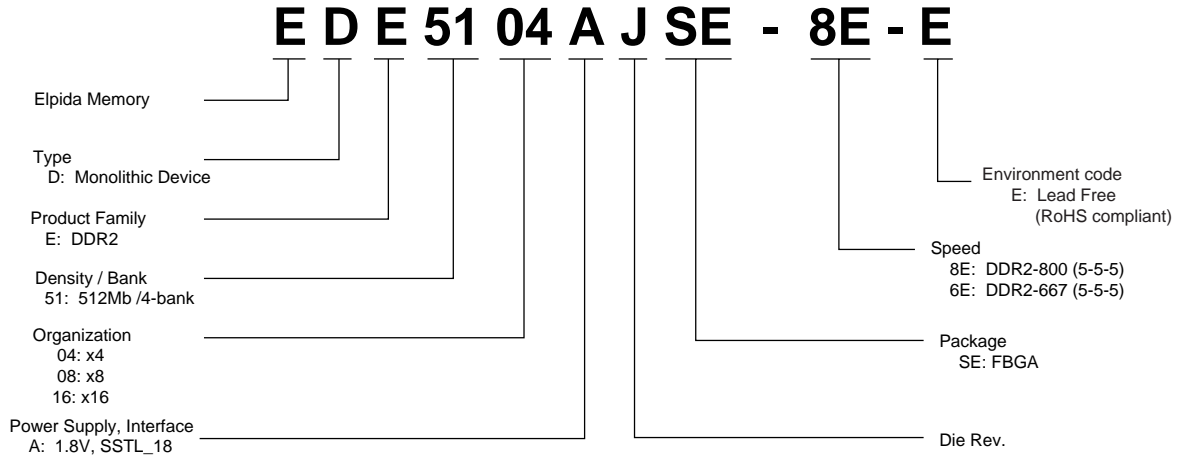

Pin Configurations

/xxx indicates active low signal.

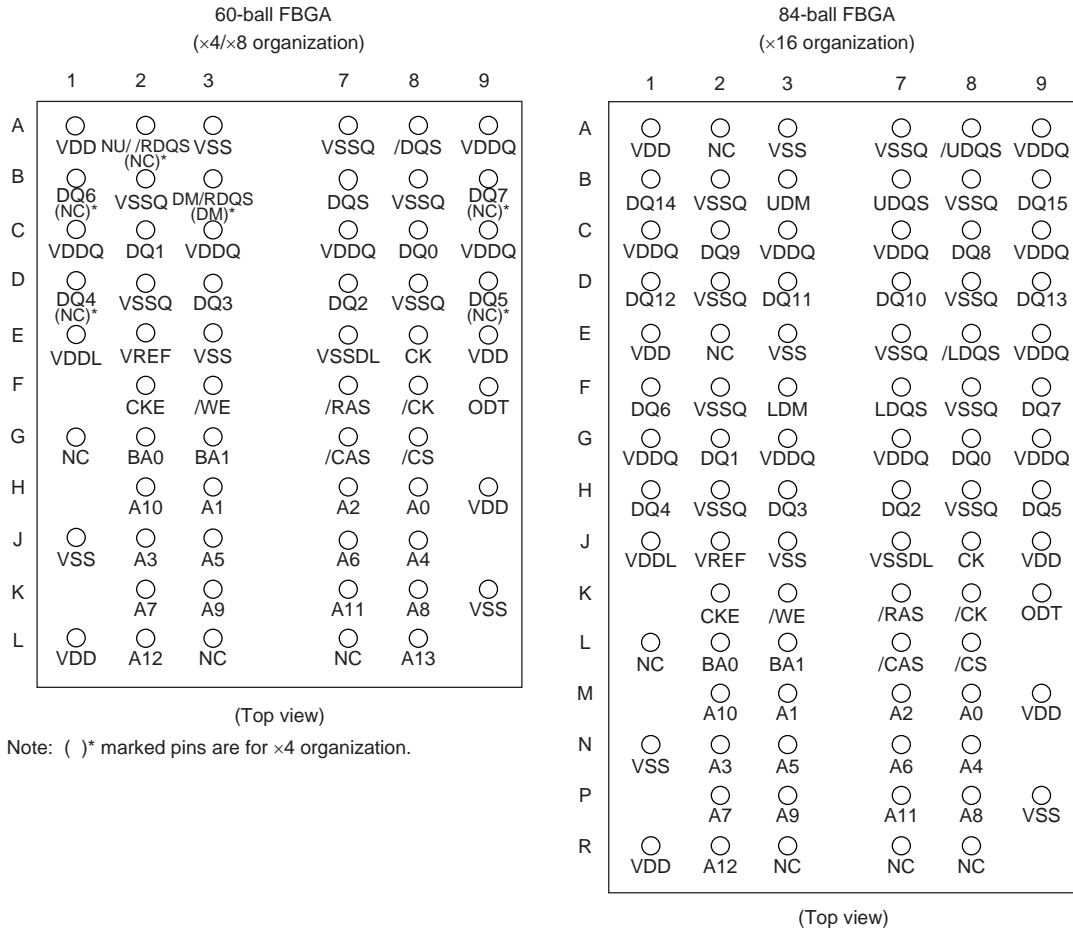

Pin name	Function	Pin name	Function
A0 to A13	Address inputs	ODT	ODT control
BA0, BA1	Bank select	VDD	Supply voltage for internal circuit
DQ0 to DQ15	Data input/output	VSS	Ground for internal circuit
DQS, /DQS	Differential data strobe	VDDQ	Supply voltage for DQ circuit
UDQS, /UDQS			
LDQS, /LDQS			
RDQS, /RDQS	Differential data strobe for read	VSSQ	Ground for DQ circuit
/CS	Chip select	VREF	Input reference voltage
/RAS, /CAS, /WE	Command input	VDDL	Supply voltage for DLL circuit
CKE	Clock enable	VSSDL	Ground for DLL circuit
CK, /CK	Differential clock input	NC ^{*1}	No connection
DM	Write data mask	NU ^{*2}	Not usable
UDM, LDM			

Notes: 1. Not internally connected with die.
 2. Don't use other than reserved functions.

CONTENTS

Specifications.....1
Features.....1
Ordering Information.....2
Part Number2
Pin Configurations3
Electrical Specifications.....5
Block Diagram24
Pin Function.....25
Command Operation27
Simplified State Diagram35
Operation of DDR2 SDRAM.....36
Package Drawing73
Recommended Soldering Conditions.....75

Electrical Specifications

- All voltages are referenced to VSS (GND)
- Execute power-up and Initialization sequence before proper device operation is achieved.

Absolute Maximum Ratings

Parameter	Symbol	Rating	Unit	Notes
Power supply voltage	VDD	-1.0 to +2.3	V	1
Power supply voltage for output	VDDQ	-0.5 to +2.3	V	1
Input voltage	VIN	-0.5 to +2.3	V	1
Output voltage	VOUT	-0.5 to +2.3	V	1
Storage temperature	Tstg	-55 to +100	°C	1, 2
Power dissipation	PD	1.0	W	1
Short circuit output current	IOUT	50	mA	1

Notes: 1. Stresses greater than those listed under Absolute Maximum Ratings may cause permanent damage to the device. This is a stress rating only and functional operation of the device at these or any other conditions above those indicated in the operational sections of this specification is not implied. Exposure to absolute maximum rating conditions for extended periods may affect reliability.

2. Storage temperature is the case surface temperature on the center/top side of the DRAM.

Caution

Exposing the device to stress above those listed in Absolute Maximum Ratings could cause permanent damage. The device is not meant to be operated under conditions outside the limits described in the operational section of this specification. Exposure to Absolute Maximum Rating conditions for extended periods may affect device reliability.

Operating Temperature Condition

Parameter	Symbol	Rating	Unit	Notes
Operating case temperature	TC	0 to +95	°C	1, 2

Notes: 1. Operating temperature is the case surface temperature on the center/top side of the DRAM.

2. Supporting 0°C to +85°C with full AC and DC specifications.

Supporting 0°C to +85°C and being able to extend to +95°C with doubling auto-refresh commands in frequency to a 32ms period (tREFI = 3.9µs) and higher temperature Self-Refresh entry via A7 "1" on EMRS (2).

Recommended DC Operating Conditions (SSTL_18)

Parameter	Symbol	min.	typ.	max.	Unit	Notes
Supply voltage	VDD	1.7	1.8	1.9	V	4
Supply voltage for output	VDDQ	1.7	1.8	1.9	V	4
Input reference voltage	VREF	$0.49 \times VDDQ$	$0.50 \times VDDQ$	$0.51 \times VDDQ$	V	1, 2
Termination voltage	VTT	$VREF - 0.04$	VREF	$VREF + 0.04$	V	3
DC input logic high	VIH (DC)	$VREF + 0.125$	—	$VDDQ + 0.3$	V	
DC input low	VIL (DC)	-0.3	—	$VREF - 0.125$	V	
AC input logic high -8E, -6E	VIH (AC)	$VREF + 0.200$	—	—	V	
AC input low -8E, -6E	VIL (AC)	—	—	$VREF - 0.200$	V	

Notes: 1. The value of VREF may be selected by the user to provide optimum noise margin in the system. Typically the value of VREF is expected to be about $0.5 \times VDDQ$ of the transmitting device and VREF are expected to track variations in VDDQ.

2. Peak to peak AC noise on VREF may not exceed $\pm 2\%$ VREF (DC).
3. VTT of transmitting device must track VREF of receiving device.
4. VDDQ tracks with VDD, VDDL tracks with VDD. AC parameters are measured with VDD, VDDQ and VDDL tied together.

AC Overshoot/Undershoot Specification

Parameter	Pins	Specification	Unit
Maximum peak amplitude allowed for overshoot	Command, Address, CKE, ODT	0.5	V
Maximum peak amplitude allowed for undershoot		0.5	V
Maximum overshoot area above VDD DDR2-800		0.66	V-ns
DDR2-667		0.8	V-ns
Maximum undershoot area below VSS DDR2-800		0.66	V-ns
DDR2-667		0.8	V-ns
Maximum peak amplitude allowed for overshoot	CK, /CK	0.5	V
Maximum peak amplitude allowed for undershoot		0.5	V
Maximum overshoot area above VDD DDR2-800, 667		0.23	V-ns
Maximum undershoot area below VSS DDR2-800, 667		0.23	V-ns
Maximum peak amplitude allowed for overshoot	DQ, DQS, /DQS,	0.5	V
Maximum peak amplitude allowed for undershoot	UDQS, /UDQS, LDQS, /LDQS,	0.5	V
Maximum overshoot area above VDDQ DDR2-800, 667	RDQS, /RDQS, DM, UDM, LDM	0.23	V-ns
Maximum undershoot area below VSSQ DDR2-800, 667		0.23	V-ns

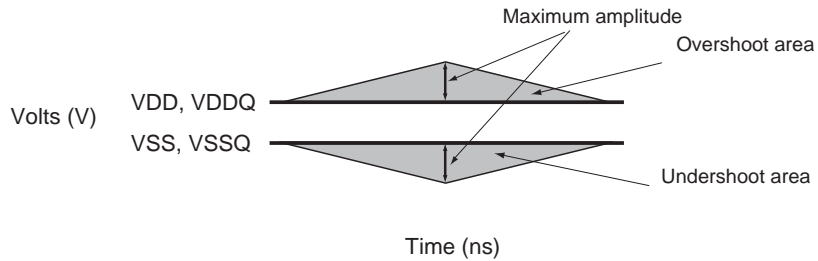

Overshoot/Undershoot Definition

DC Characteristics 1 (TC = 0°C to +85°C, VDD, VDDQ = 1.8V ± 0.1V)

Parameter	Symbol	Grade	×4	×8	×16	Unit	Test condition
			max.	max.	max.		
Operating current (ACT-PRE)	IDD0	-8E	55	55	70	mA	one bank; tCK = tCK (IDD), tRC = tRC (IDD), tRAS = tRAS min.(IDD); CKE is H, /CS is H between valid commands; Address bus inputs are SWITCHING; Data bus inputs are SWITCHING
		-6E	50	50	65		
Operating current (ACT-READ-PRE)	IDD1	-8E	65	65	85	mA	one bank; IOU = 0mA; BL = 4, CL = CL(IDD), AL = 0; tCK = tCK (IDD), tRC = tRC (IDD), tRAS = tRAS min.(IDD); tRCD = tRCD (IDD); CKE is H, /CS is H between valid commands; Address bus inputs are SWITCHING; Data pattern is same as IDD4W
		-6E	60	60	80		
Precharge power-down standby current	IDD2P	-8E	10	10	10	mA	all banks idle; tCK = tCK (IDD); CKE is L; Other control and address bus inputs are STABLE; Data bus inputs are FLOATING
		-6E	10	10	10		
Precharge quiet standby current	IDD2Q	-8E	15	15	15	mA	all banks idle; tCK = tCK (IDD); CKE is H, /CS is H; Other control and address bus inputs are STABLE; Data bus inputs are FLOATING
		-6E	15	15	15		
Idle standby current	IDD2N	-8E	20	20	20	mA	all banks idle; tCK = tCK (IDD); CKE is H, /CS is H; Other control and address bus inputs are SWITCHING; Data bus inputs are SWITCHING
		-6E	20	20	20		
Active power-down standby current	IDD3P-F	-8E	15	15	15	mA	all banks open; tCK = tCK (IDD); CKE is L; Other control and address bus inputs are STABLE; Data bus inputs are FLOATING
		-6E	15	15	15		
	IDD3P-S	-8E	12	12	12	mA	Slow PDN Exit MRS(12) = 1
		-6E	12	12	12		
Active standby current	IDD3N	-8E	40	40	40	mA	all banks open; tCK = tCK (IDD), tRAS = tRAS max.(IDD), tRP = tRP (IDD); CKE is H, /CS is H between valid commands; Other control and address bus inputs are SWITCHING; Data bus inputs are SWITCHING
		-6E	35	35	35		
Operating current (Burst read operating)	IDD4R	-8E	125	125	170	mA	all banks open, continuous burst reads, IOU = 0mA; BL = 4, CL = CL(IDD), AL = 0; tCK = tCK (IDD), tRAS = tRAS max.(IDD), tRP = tRP (IDD); CKE is H, /CS is H between valid commands; Address bus inputs are SWITCHING; Data pattern is same as IDD4W
		-6E	110	110	145		
Operating current (Burst write operating)	IDD4W	-8E	120	120	160	mA	all banks open, continuous burst writes; BL = 4, CL = CL(IDD), AL = 0; tCK = tCK (IDD), tRAS = tRAS max.(IDD), tRP = tRP (IDD); CKE is H, /CS is H between valid commands; Address bus inputs are SWITCHING; Data bus inputs are SWITCHING
		-6E	105	105	140		

Parameter	Symbol	Grade	×4	×8	×16	Unit	Test condition
			max.	max.	max.		
Auto-refresh current	IDD5	-8E -6E	105 100	105 100	105 100	mA	tCK = tCK (IDD); Refresh command at every tRFC (IDD) interval; CKE is H, /CS is H between valid commands; Other control and address bus inputs are SWITCHING; Data bus inputs are SWITCHING
Self-refresh current	IDD6*7		6	6	6	mA	Self Refresh Mode; CK and /CK at 0V; CKE ≤ 0.2V; Other control and address bus inputs are FLOATING; Data bus inputs are FLOATING
Operating current (Bank interleaving)	IDD7	-8E -6E	160 150	160 150	240 230	mA	all bank interleaving reads, IOUT = 0mA; BL = 4, CL = CL(IDD), AL = tRCD (IDD) - 1 × tCK (IDD); tCK = tCK (IDD), tRC = tRC (IDD), tRRD = tRRD(IDD), tRCD = 1 × tCK (IDD); CKE is H, /CS is H between valid commands; Address bus inputs are STABLE during DESELECTs; Data pattern is same as IDD4W

- Notes: 1. IDD specifications are tested after the device is properly initialized.
 2. Input slew rate is specified by AC Input Test Condition.
 3. IDD parameters are specified with ODT disabled.
 4. Data bus consists of DQ, DM, DQS, /DQS, RDQS and /RDQS. IDD values must be met with all combinations of EMRS bits 10 and 11.
 5. Definitions for IDD
 L is defined as $V_{IN} \leq V_{IL} (AC) (max.)$
 H is defined as $V_{IN} \geq V_{IH} (AC) (min.)$
 STABLE is defined as inputs stable at an H or L level
 FLOATING is defined as inputs at $V_{REF} = V_{DDQ}/2$
 SWITCHING is defined as:
 inputs changing between H and L every other clock cycle (once per two clocks) for address and control signals, and inputs changing between H and L every other data transfer (once per clock) for DQ signals not including masks or strobes.
 6. Refer to AC Timing for IDD Test Conditions.
 7. When $TC \geq +85^{\circ}C$, IDD6 must be derated by 80%.
 IDD6 will increase by this amount if $TC \geq +85^{\circ}C$ and double refresh option is still enabled.

AC Timing for IDD Test Conditions

For purposes of IDD testing, the following parameters are to be utilized.

Parameter	DDR2-800	DDR2-667	Unit
	5-5-5	5-5-5	
CL (IDD)	5	5	tCK
tRCD (IDD)	12.5	15	ns
tRC (IDD)	57.5	60	ns
tRRD (IDD)- ×4/×8	7.5	7.5	ns
tRRD (IDD)-×16	10	10	ns
tCK (IDD)	2.5	3	ns
tRAS (min.)(IDD)	45	45	ns
tRAS (max.)(IDD)	70000	70000	ns
tRP (IDD)	12.5	15	ns
tRFC (IDD)	105	105	ns

DC Characteristics 2 (TC = 0°C to +85°C, VDD, VDDQ = 1.8V ± 0.1V)

Parameter	Symbol	Value	Unit	Notes
Input leakage current	ILI	2	μA	VDD ≥ VIN ≥ VSS
Output leakage current	ILO	5	μA	VDDQ ≥ VOUT ≥ VSS
Minimum required output pull-up under AC test load	VOH	VTT + 0.603	V	5
Maximum required output pull-down under AC test load	VOL	VTT - 0.603	V	5
Output timing measurement reference level	VOTR	0.5 × VDDQ	V	1
Output minimum sink DC current	IOL	+13.4	mA	3, 4, 5
Output minimum source DC current	IOH	-13.4	mA	2, 4, 5

- Notes: 1. The VDDQ of the device under test is referenced.
 2. VDDQ = 1.7V; VOUT = 1.42V.
 3. VDDQ = 1.7V; VOUT = 0.28V.
 4. The DC value of VREF applied to the receiving device is expected to be set to VTT.
 5. After OCD calibration to 18Ω at TC = 25°C, VDD = VDDQ = 1.8V.

DC Characteristics 3 (TC = 0°C to +85°C, VDD, VDDQ = 1.8V ± 0.1V)

Parameter	Symbol	min.	max.	Unit	Notes
AC differential input voltage	VID (AC)	0.5	VDDQ + 0.6	V	1, 2
AC differential cross point voltage	VIX (AC)	0.5 × VDDQ - 0.175	0.5 × VDDQ + 0.175	V	2
AC differential cross point voltage	VOX (AC)	0.5 × VDDQ - 0.125	0.5 × VDDQ + 0.125	V	3

- Notes: 1. VID (AC) specifies the input differential voltage |VTR -VCP| required for switching, where VTR is the true input signal (such as CK, DQS, RDQS) and VCP is the complementary input signal (such as /CK, /DQS, /RDQS). The minimum value is equal to VIH (AC) - VIL (AC).
 2. The typical value of VIX (AC) is expected to be about 0.5 × VDDQ of the transmitting device and VIX (AC) is expected to track variations in VDDQ. VIX (AC) indicates the voltage at which differential input signals must cross.
 3. The typical value of VOX (AC) is expected to be about 0.5 × VDDQ of the transmitting device and VOX (AC) is expected to track variations in VDDQ. VOX (AC) indicates the voltage at which differential output signals must cross.

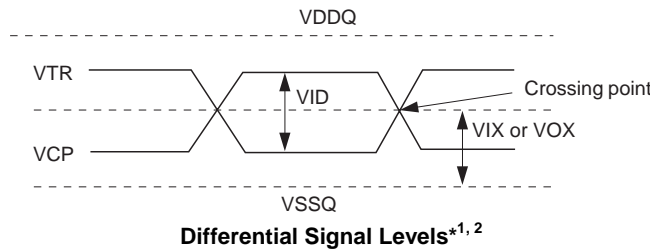

ODT DC Electrical Characteristics (TC = 0°C to +85°C, VDD, VDDQ = 1.8V ± 0.1V)

Parameter	Symbol	min.	typ.	max.	Unit	Note
Rtt effective impedance value for EMRS (A6, A2) = 0, 1; 75 Ω	Rtt1 (eff)	60	75	90	Ω	1
Rtt effective impedance value for EMRS (A6, A2) = 1, 0; 150 Ω	Rtt2 (eff)	120	150	180	Ω	1
Rtt effective impedance value for EMRS (A6, A2) = 1, 1; 50 Ω	Rtt3 (eff)	40	50	60	Ω	1
Deviation of VM with respect to VDDQ/2	ΔVM	-6	—	+6	%	1

Note: 1. Test condition for Rtt measurements.

Measurement Definition for Rtt (eff)

Apply VIH (AC) and VIL (AC) to test pin separately, then measure current I(VIH (AC)) and I(VIL (AC)) respectively. VIH (AC), and VDDQ values defined in SSTL_18.

$$R_{tt}(\text{eff}) = \frac{V_{IH}(\text{AC}) - V_{IL}(\text{AC})}{I(V_{IH}(\text{AC})) - I(V_{IL}(\text{AC}))}$$

Measurement Definition for ΔVM

Measure voltage (VM) at test pin (midpoint) with no load.

$$\Delta VM = \left(\frac{2 \times VM}{VDDQ} - 1 \right) \times 100$$

OCD Default Characteristics (TC = 0°C to +85°C, VDD, VDDQ = 1.8V ± 0.1V)

Parameter	min.	typ.	max.	Unit	Notes
Output impedance	12.6	18	23.4	Ω	1, 5
Pull-up and pull-down mismatch	0	—	4	Ω	1, 2
Output slew rate	1.5	—	5	V/ns	3, 4

Notes: 1. Impedance measurement condition for output source DC current: VDDQ = 1.7V; VOUT = 1420mV; (VOUT-VDDQ)/IOH must be less than 23.4Ω for values of VOUT between VDDQ and VDDQ-280mV. Impedance measurement condition for output sink DC current: VDDQ = 1.7V; VOUT = 280mV; VOUT/IOL must be less than 23.4Ω for values of VOUT between 0V and 280mV.

- Mismatch is absolute value between pull up and pull down, both are measured at same temperature and voltage.
- Slew rate measured from VIL (AC) to VIH (AC).
- The absolute value of the slew rate as measured from DC to DC is equal to or greater than the slew rate as measured from AC to AC. This is guaranteed by design and characterization.
- DRAM I/O specifications for timing, voltage, and slew rate are no longer applicable if OCD is changed from default settings.

Pin Capacitance (TA = 25°C, VDD, VDDQ = 1.8V ± 0.1V)

Parameter	Symbol	Pins	min.	max.	Unit	Notes
CLK input pin capacitance	CCK	CK, /CK	1.0	2.0	pF	1
Input pin capacitance -8E	CIN	/RAS, /CAS, /WE, /CS,	1.0	1.75	pF	1
-6E		CKE, ODT, Address	1.0	2.0	pF	1
Input/output pin capacitance	CI/O	DQ, DQS, /DQS, UDQS, /UDQS, LDQS, /LDQS, RDQS, /RDQS, DM, UDM, LDM	2.5	3.5	pF	2

Notes: 1. Matching within 0.25pF.
2. Matching within 0.50pF.

AC Characteristics (TC = 0°C to +85°C, VDD, VDDQ = 1.8V ± 0.1V, VSS, VSSQ = 0V) [DDR2-800, 667]

- New units tCK(avg) and nCK, are introduced in DDR2-800 and DDR2-667
tCK(avg): actual tCK(avg) of the input clock under operation.
nCK: one clock cycle of the input clock, counting the actual clock edges.

Speed bin	Parameter	Symbol	-8E		-6E		Unit	Notes
			DDR2-800 (5-5-5)		DDR2-667 (5-5-5)			
			min.	max.	min.	max.		
	Active to read or write command delay	tRCD	12.5	—	15	—	ns	
	Precharge command period	tRP	12.5	—	15	—	ns	
	Active to active/auto-refresh command time	tRC	57.5	—	60	—	ns	
	DQ output access time from CK, /CK	tAC	-400	+400	-450	+450	ps	10
	DQS output access time from CK, /CK	tDQSQ	-350	+350	-400	+400	ps	10
	CK high-level width	tCH (avg)	0.48	0.52	0.48	0.52	tCK (avg)	13
	CK low-level width	tCL (avg)	0.48	0.52	0.48	0.52	tCK (avg)	13
	CK half period	tHP	Min. (tCL(abs), tCH(abs))		Min. (tCL(abs), tCH(abs))		ps	6, 13
	Clock cycle time (CL = 6)	tCK (avg)	2500	8000	3000	8000	ps	13
	(CL = 5)	tCK (avg)	2500	8000	3000	8000	ps	13
	(CL = 4)	tCK (avg)	3750	8000	3750	8000	ps	13
	(CL = 3)	tCK (avg)	5000	8000	5000	8000	ps	13
	DQ and DM input hold time	tDH (base)	125	—	175	—	ps	5
	DQ and DM input setup time	tDS (base)	50	—	100	—	ps	4
	Control and Address input pulse width for each input	tIPW	0.6	—	0.6	—	tCK (avg)	
	DQ and DM input pulse width for each input	tDIPW	0.35	—	0.35	—	tCK (avg)	
	Data-out high-impedance time from CK,/CK	tHZ	—	tAC max.	—	tAC max.	ps	10
	DQS, /DQS low-impedance time from CK,/CK	tLZ (DQS)	tAC min.	tAC max.	tAC min.	tAC max.	ps	10
	DQ low-impedance time from CK,/CK	tLZ (DQ)	2 × tAC min.	tAC max.	2 × tAC min.	tAC max.	ps	10
	DQS-DQ skew for DQS and associated DQ signals	tDQSQ	—	200	—	240	ps	
	DQ hold skew factor	tQHS	—	300	—	340	ps	7
	DQ/DQS output hold time from DQS	tQH	tHP – tQHS	—	tHP – tQHS	—	ps	8
	DQS latching rising transitions to associated clock edges	tDQSS	-0.25	+0.25	-0.25	+0.25	tCK (avg)	
	DQS input high pulse width	tDQSH	0.35	—	0.35	—	tCK (avg)	
	DQS input low pulse width	tDQSL	0.35	—	0.35	—	tCK (avg)	
	DQS falling edge to CK setup time	tDSS	0.2	—	0.2	—	tCK (avg)	
	DQS falling edge hold time from CK	tDSH	0.2	—	0.2	—	tCK (avg)	
	Mode register set command cycle time	tMRD	2	—	2	—	nCK	
	Write postamble	tWPST	0.4	0.6	0.4	0.6	tCK (avg)	
	Write preamble	tWPRE	0.35	—	0.35	—	tCK (avg)	
	Address and control input hold time	tIH (base)	250	—	275	—	ps	5
	Address and control input setup time	tIS (base)	175	—	200	—	ps	4
	Read preamble	tRPRE	0.9	1.1	0.9	1.1	tCK (avg)	11
	Read postamble	tRPST	0.4	0.6	0.4	0.6	tCK (avg)	12
	Active to precharge command	tRAS	45	70000	45	70000	ns	

Speed bin	Parameter	Symbol	-8E		-6E		Unit	Notes
			min.	max.	min.	max.		
			DDR2-800 (5-5-5)		DDR2-667 (5-5-5)			
	Active to auto-precharge delay	tRAP	tRCD min.	—	tRCD min.	—	ns	
	Active bank A to active bank B command period (EDE5104/08AJ)	tRRD	7.5	—	7.5	—	ns	
	(EDE5116AJ)	tRRD	10	—	10	—	ns	
	/CAS to /CAS command delay	tCCD	2	—	2	—	nCK	
	Write recovery time	tWR	15	—	15	—	ns	
	Auto precharge write recovery + precharge time	tDAL	WR + RU (tRP/tCK(avg))	—	WR + RU (tRP/tCK(avg))	—	nCK	1, 9
	Internal write to read command delay	tWTR	7.5	—	7.5	—	ns	14
	Internal read to precharge command delay	tRTP	7.5	—	7.5	—	ns	
	Exit self-refresh to a non-read command	tXSNR	tRFC + 10	—	tRFC + 10	—	ns	
	Exit self-refresh to a read command	tXSRD	200	—	200	—	nCK	
	Exit precharge power down to any non-read command	tXP	2	—	2	—	nCK	
	Exit active power down to read command	tXARD	2	—	2	—	nCK	3
	Exit active power down to read command (slow exit/low power mode)	tXARDS	8 – AL	—	7 – AL	—	nCK	2, 3
	CKE minimum pulse width (high and low pulse width)	tCKE	3	—	3	—	nCK	
	Output impedance test driver delay	tOIT	0	12	0	12	ns	
	MRS command to ODT update delay	tMOD	0	12	0	12	ns	
	Auto-refresh to active/auto-refresh command time	tRFC	105	—	105	—	ns	
	Average periodic refresh interval (0°C ≤ TC ≤ +85°C)	tREFI	—	7.8	—	7.8	μs	
	(+85°C < TC ≤ +95°C)	tREFI	—	3.9	—	3.9	μs	
	Minimum time clocks remains ON after CKE asynchronously drops low	tDELAY	tIS + tCK(avg) + tIH	—	tIS + tCK(avg) + tIH	—	ns	

Notes: 1. For each of the terms above, if not already an integer, round to the next higher integer.

2. AL: Additive Latency.

3. MRS A12 bit defines which active power-down exit timing to be applied.

4. The figures of Input Waveform Timing 1 and 2 are referenced from the input signal crossing at the VIH(AC) level for a rising signal and VIL(AC) for a falling signal applied to the device under test.

5. The figures of Input Waveform Timing 1 and 2 are referenced from the input signal crossing at the VIL(DC) level for a rising signal and VIH(DC) for a falling signal applied to the device under test.

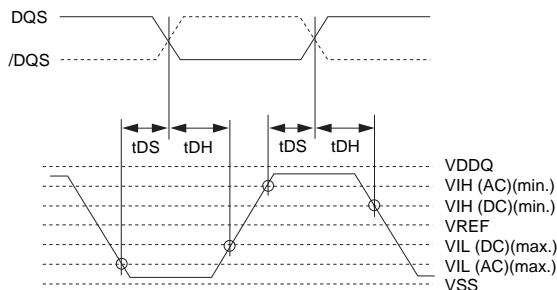

Input Waveform Timing 1 (tDS, tDH)

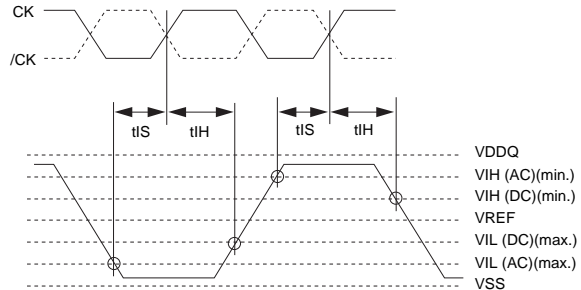

Input Waveform Timing 2 (tIS, tIH)

6. tHP is the minimum of the absolute half period of the actual input clock. tHP is an input parameter but not an input specification parameter. It is used in conjunction with tQHS to derive the DRAM output timing tQH.

The value to be used for tQH calculation is determined by the following equation;

$$tHP = \min (tCH(abs), tCL(abs)),$$

where,

tCH(abs) is the minimum of the actual instantaneous clock high time;

tCL(abs) is the minimum of the actual instantaneous clock low time;

7. tQHS accounts for:
- The pulse duration distortion of on-chip clock circuits, which represents how well the actual tHP at the input is transferred to the output; and
 - The worst case push-out of DQS on one transition followed by the worst case pull-in of DQ on the next transition, both of which are independent of each other, due to data pin skew, output pattern effects, and p-channel to n-channel variation of the output drivers.
8. $tQH = tHP - tQHS$, where:
- tHP is the minimum of the absolute half period of the actual input clock; and tQHS is the specification value under the max column.
- {The less half-pulse width distortion present, the larger the tQH value is; and the larger the valid data eye will be.}
- Examples:
- If the system provides tHP of 1315ps into a DDR2-667 SDRAM, the DRAM provides tQH of 975ps (min.)
 - If the system provides tHP of 1420ps into a DDR2-667 SDRAM, the DRAM provides tQH of 1080ps (min.)
9. RU stands for round up. WR refers to the tWR parameter stored in the MRS.
10. When the device is operated with input clock jitter, this parameter needs to be derated by the actual tERR(6-10per) of the input clock. (output deratings are relative to the SDRAM input clock.)
- For example, if the measured jitter into a DDR2-667 SDRAM has tERR(6-10per) min. = -272ps and tERR(6-10per) max. = +293ps, then tDQSCK min.(derated) = tDQSCK min. - tERR(6-10per) max. = -400ps - 293ps = -693ps and tDQSCK max.(derated) = tDQSCK max. - tERR(6-10per) min. = 400ps + 272ps = +672ps. Similarly, tLZ(DQ) for DDR2-667 derates to tLZ(DQ) min.(derated) = -900ps - 293ps = -1193ps and tLZ(DQ) max.(derated) = 450ps + 272ps = +722ps.
11. When the device is operated with input clock jitter, this parameter needs to be derated by the actual tJIT(per) of the input clock. (output deratings are relative to the SDRAM input clock.)
- For example, if the measured jitter into a DDR2-667 SDRAM has tJIT(per) min. = -72ps and tJIT(per) max. = +93ps, then tRPRE min.(derated) = tRPRE min. + tJIT(per) min. = $0.9 \times tCK(ave) - 72ps = +2178ps$ and tRPRE max.(derated) = tRPRE max. + tJIT(per) max. = $1.1 \times tCK(ave) + 93ps = +2843ps$.
12. When the device is operated with input clock jitter, this parameter needs to be derated by the actual tJIT(duty) of the input clock. (output deratings are relative to the SDRAM input clock.)
- For example, if the measured jitter into a DDR2-667 SDRAM has tJIT(duty) min. = -72ps and tJIT(duty) max. = +93ps, then tRPST min.(derated) = tRPST min. + tJIT(duty) min. = $0.4 \times tCK(ave) - 72ps = +928ps$ and tRPST max.(derated) = tRPST max. + tJIT(duty) max. = $0.6 \times tCK(ave) + 93ps = +1592ps$.
13. Refer to the Clock Jitter table.
14. tWTR is at least two clocks ($2 \times tCK$ or $2 \times nCK$) independent of operation frequency.

ODT AC Electrical Characteristics

Parameter	Symbol	min.	max.	Unit	Notes
ODT turn-on delay	tAOND	2	2	tCK	
ODT turn-on	tAON	tAC(min)	tAC(max) + 700	ps	1, 3
ODT turn-on (power-down mode)	tAONPD	tAC(min) + 2000	2tCK + tAC(max) + 1000	ps	
ODT turn-off delay	tAOFD	2.5	2.5	tCK	5
ODT turn-off	tAOF	tAC(min)	tAC(max) + 600	ps	2, 4, 5
ODT turn-off (power-down mode)	tAOFPD	tAC(min) + 2000	2.5tCK + tAC(max) + 1000	ps	
ODT to power-down entry latency	tANPD	3	3	tCK	
ODT power-down exit latency	tAXPD	8	8	tCK	

- Notes: 1. ODT turn on time min is when the device leaves high impedance and ODT resistance begins to turn on. ODT turn on time max is when the ODT resistance is fully on. Both are measured from tAOND.
2. ODT turn off time min is when the device starts to turn off ODT resistance. ODT turn off time max is when the bus is in high impedance. Both are measured from tAOFD.
3. When the device is operated with input clock jitter, this parameter needs to be derated by the actual tERR(6-10per) of the input clock. (output deratings are relative to the SDRAM input clock.)
4. When the device is operated with input clock jitter, this parameter needs to be derated by { -tJIT(duty) max. - tERR(6-10per) max. } and { -tJIT(duty) min. - tERR(6-10per) min. } of the actual input clock.(output deratings are relative to the SDRAM input clock.)
 For example, if the measured jitter into a DDR2-667 SDRAM has tERR(6-10per) min. = -272ps, tERR(6-10per) max. = +293ps, tJIT(duty) min. = -106ps and tJIT(duty) max. = +94ps, then tAOF min.(derated) = tAOF min. + { -tJIT(duty) max. - tERR(6-10per) max. } = -450ps + { -94ps - 293ps } = -837ps and tAOF max.(derated) = tAOF max. + { -tJIT(duty) min. - tERR(6-10per) min. } = 1050ps + { 106ps + 272ps } = +1428ps.
5. For tAOFD of DDR2-667/800, the 1/2 clock of nCK in the 2.5 × nCK assumes a tCH(avg), average input clock high pulse width of 0.5 relative to tCK(avg). tAOF min. and tAOF max. should each be derated by the same amount as the actual amount of tCH(avg) offset present at the DRAM input with respect to 0.5. For example, if an input clock has a worst case tCH(avg) of 0.48, the tAOF min. should be derated by subtracting 0.02 × tCK(avg) from it, whereas if an input clock has a worst case tCH(avg) of 0.52, the tAOF max. should be derated by adding 0.02 × tCK(avg) to it. Therefore, we have;
- $$tAOF \text{ min. (derated) } = tAC \text{ min.} - [0.5 - \text{Min.}(0.5, tCH(\text{avg}) \text{ min.})] \times tCK(\text{avg})$$
- $$tAOF \text{ max. (derated) } = tAC \text{ max.} + 0.6 + [\text{Max.}(0.5, tCH(\text{avg}) \text{ max.}) - 0.5] \times tCK(\text{avg})$$
- or
- $$tAOF \text{ min. (derated) } = \text{Min.}(tAC \text{ min.}, tAC \text{ min.} - [0.5 - tCH(\text{avg}) \text{ min.}] \times tCK(\text{avg}))$$
- $$tAOF \text{ max. (derated) } = 0.6 + \text{Max.}(tAC \text{ max.}, tAC \text{ max.} + [tCH(\text{avg}) \text{ max.} - 0.5] \times tCK(\text{avg}))$$
- where tCH(avg) min. and tCH(avg) max. are the minimum and maximum of tCH(avg) actually measured at the DRAM input balls.

AC Input Test Conditions

Parameter	Symbol	Value	Unit	Notes
Input reference voltage	VREF	$0.5 \times VDDQ$	V	1
Input signal maximum peak to peak swing	VSWING(max.)	1.0	V	1
Input signal minimum slew rate	SLEW	1.0	V/ns	2, 3

- Notes: 1. Input waveform timing is referenced to the input signal crossing through the VIH/IL (AC) level applied to the device under test.
2. The input signal minimum slew rate is to be maintained over the range from VREF to VIH(AC) (min.) for rising edges and the range from VREF to VIL(AC) (max.) for falling edges as shown in the below figure.
3. AC timings are referenced with input waveforms switching from VIL(AC) to VIH(AC) on the positive transitions and VIH(AC) to VIL(AC) on the negative transitions.

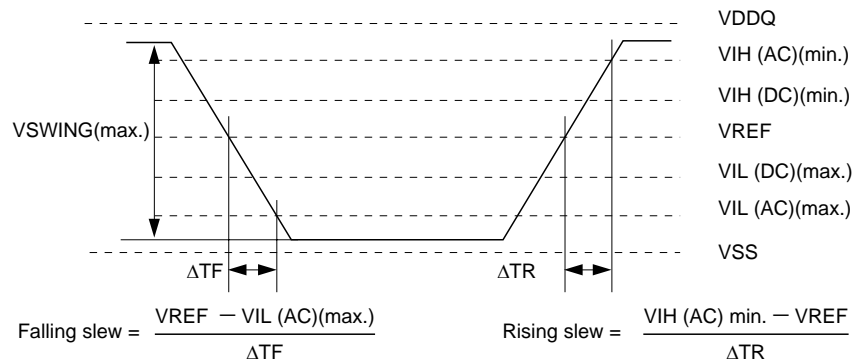

AC Input Test Signal Wave forms

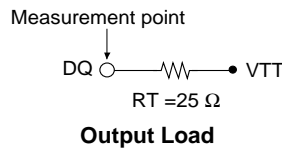

Clock Jitter [DDR2-800, 667]

Frequency (Mbps)	Parameter	Symbol	-8E		-6E		Unit	Notes
			800	667	min.	max.		
	Average clock period	tCK (avg)	2500	8000	3000	8000	ps	1
	Clock period jitter	tJIT (per)	-100	100	-125	125	ps	5
	Clock period jitter during DLL locking period	tJIT (per, lck)	-80	80	-100	100	ps	5
	Cycle to cycle period jitter	tJIT (cc)	—	200	—	250	ps	6
	Cycle to cycle clock period jitter during DLL locking period	tJIT (cc, lck)	—	160	—	200	ps	6
	Cumulative error across 2 cycles	tERR (2per)	-150	150	-175	175	ps	7
	Cumulative error across 3 cycles	tERR (3per)	-175	175	-225	225	ps	7
	Cumulative error across 4 cycles	tERR (4per)	-200	200	-250	250	ps	7
	Cumulative error across 5 cycles	tERR (5per)	-200	200	-250	250	ps	7
	Cumulative error across n=6,7,8,9,10 cycles	tERR (6-10per)	-300	300	-350	350	ps	7
	Cumulative error across n=11, 12,...49,50 cycles	tERR (11-50per)	-450	450	-450	450	ps	7
	Average high pulse width	tCH (avg)	0.48	0.52	0.48	0.52	tCK (avg)	2
	Average low pulse width	tCL (avg)	0.48	0.52	0.48	0.52	tCK (avg)	3
	Duty cycle jitter	tJIT (duty)	-100	100	-125	125	ps	4

Notes: 1. tCK (avg) is calculated as the average clock period across any consecutive 200cycle window.

$$tCK(avg) = \left\{ \sum_{j=1}^N tCK_j \right\} / N$$

N = 200

2. tCH (avg) is defined as the average high pulse width, as calculated across any consecutive 200 high pulses.

$$tCH(avg) = \left\{ \sum_{j=1}^N tCH_j \right\} / (N \times tCK(avg))$$

N = 200

3. tCL (avg) is defined as the average low pulse width, as calculated across any consecutive 200 low pulses.

$$tCL(avg) = \left\{ \sum_{j=1}^N tCL_j \right\} / (N \times tCK(avg))$$

N = 200

4. tJIT (duty) is defined as the cumulative set of tCH jitter and tCL jitter. tCH jitter is the largest deviation of any single tCH from tCH (avg). tCL jitter is the largest deviation of any single tCL from tCL (avg). tJIT (duty) is not subject to production test.

tJIT (duty) = Min./Max. of {tJIT (CH), tJIT (CL)}, where:

tJIT (CH) = {tCH_j - tCH (avg) where j = 1 to 200}

tJIT (CL) = {tCL_j - tCL (avg) where j = 1 to 200}

5. tJIT (per) is defined as the largest deviation of any single tCK from tCK (avg).

tJIT (per) = Min./Max. of { tCK_j - tCK (avg) where j = 1 to 200}

tJIT (per) defines the single period jitter when the DLL is already locked. tJIT (per, lck) uses the same definition for single period jitter, during the DLL locking period only. tJIT (per) and tJIT (per, lck) are not subject to production test.

6. tJIT (cc) is defined as the absolute difference in clock period between two consecutive clock cycles:
 $tJIT (cc) = \text{Max. of } |tCK_{j+1} - tCK_j|$
 tJIT (cc) is defines the cycle to cycle jitter when the DLL is already locked. tJIT (cc, lck) uses the same definition for cycle to cycle jitter, during the DLL locking period only. tJIT (cc) and tJIT (cc, lck) are not subject to production test.
7. tERR (nper) is defined as the cumulative error across multiple consecutive cycles from tCK (avg).
 tERR (nper) is not subject to production test.

$$tERR(nper) = \left\{ \sum_{j=1}^n tCK_j \right\} - n \times tCK(avg)$$

$2 \leq n \leq 50$ for tERR (nper)

8. These parameters are specified per their average values, however it is understood that the following relationship between the average timing and the absolute instantaneous timing hold at all times.
 (minimum and maximum of spec values are to be used for calculations in the table below.)

Parameter	Symbol	min.	max.	Unit
Absolute clock period	tCK (abs)	tCK (avg) min. + tJIT (per) min.	tCK (avg) max. + tJIT (per) max.	ps
Absolute clock high pulse width	tCH (abs)	tCH (avg) min. × tCK (avg) min. + tJIT (duty) min.	tCH (avg) max. × tCK (avg) max. + tJIT (duty) max.	ps
Absolute clock low pulse width	tCL (abs)	tCL (avg) min. × tCK (avg) min. + tJIT (duty) min.	tCL (avg) max. × tCK (avg) max. + tJIT (duty) max.	ps

Example: For DDR2-667, tCH(abs) min. = (0.48 × 3000 ps) - 125ps = 1315ps

Input Slew Rate Derating

For all input signals the total tIS, tDS (setup time) and tIH, tDH (hold time) required is calculated by adding the data sheet tIS (base), tDS (base) and tIH (base), tDH (base) value to the ΔtIS, ΔtDS and ΔtIH, ΔtDH derating value respectively.

Example: tDS (total setup time) = tDS (base) + ΔtDS.

Setup (tIS, tDS) nominal slew rate for a rising signal is defined as the slew rate between the last crossing of VREF (DC) and the first crossing of VIH (AC) min. Setup (tIS, tDS) nominal slew rate for a falling signal is defined as the slew rate between the last crossing of VREF (DC) and the first crossing of VIL (AC) max. If the actual signal is always earlier than the nominal slew rate line between shaded 'VREF (DC) to AC region', use nominal slew rate for derating value (See the figure of Slew Rate Definition Nominal).

If the actual signal is later than the nominal slew rate line anywhere between shaded 'VREF (DC) to AC region', the slew rate of a tangent line to the actual signal from the AC level to DC level is used for derating value (see the figure of Slew Rate Definition Tangent).

Hold (tIH, tDH) nominal slew rate for a rising signal is defined as the slew rate between the last crossing of VIL (DC) max. and the first crossing of VREF (DC). Hold (tIH, tDH) nominal slew rate for a falling signal is defined as the slew rate between the last crossing of VIH (DC) min. and the first crossing of VREF (DC). If the actual signal is always later than the nominal slew rate line between shaded 'DC level to VREF (DC) region', use nominal slew rate for derating value (See the figure of Slew Rate Definition Nominal).

If the actual signal is earlier than the nominal slew rate line anywhere between shaded 'DC to VREF (DC) region', the slew rate of a tangent line to the actual signal from the DC level to VREF (DC) level is used for derating value (see the figure of Slew Rate Definition Tangent).

Although for slow slew rates the total setup time might be negative (i.e. a valid input signal will not have reached VIH/IL (AC) at the time of the rising clock transition) a valid input signal is still required to complete the transition and reach VIH/IL (AC).

For slew rates in between the values listed in the tables below, the derating values may obtained by linear interpolation.

These values are typically not subject to production test. They are verified by design and characterization.

[Derating Values of tDS/tDH with Differential DQS (DDR2-667, 800)]

		DQS, /DQS differential slew rate																		Unit
		4.0 V/ns		3.0 V/ns		2.0 V/ns		1.8 V/ns		1.6 V/ns		1.4 V/ns		1.2 V/ns		1.0 V/ns		0.8 V/ns		
DQ slew rate (V/ns)		ΔtDS	ΔtDH	ΔtDS	ΔtDH	ΔtDS	ΔtDH	ΔtDS	ΔtDH	ΔtDS	ΔtDH	ΔtDS	ΔtDH	ΔtDS	ΔtDH	ΔtDS	ΔtDH	ΔtDS	ΔtDH	
		2.0	+100	+45	+100	+45	+100	+45	—	—	—	—	—	—	—	—	—	—	—	—
	1.5	+67	+21	+67	+21	+67	+21	+79	+33	—	—	—	—	—	—	—	—	—	—	ps
	1.0	0	0	0	0	0	0	+12	+12	+24	+24	—	—	—	—	—	—	—	—	ps
	0.9	—	—	-5	-14	-5	-14	+7	-2	+19	+10	+31	+22	—	—	—	—	—	—	ps
	0.8	—	—	—	—	-13	-31	-1	-19	+11	-7	+23	+5	+35	+17	—	—	—	—	ps
	0.7	—	—	—	—	—	—	-10	-42	+2	-30	+14	-18	+26	-6	+38	+6	—	—	ps
	0.6	—	—	—	—	—	—	—	—	-10	-59	+2	-47	+14	-35	+26	-23	+38	-11	ps
	0.5	—	—	—	—	—	—	—	—	—	—	-24	-89	-12	-77	0	-65	+12	-53	ps
	0.4	—	—	—	—	—	—	—	—	—	—	—	—	-52	-140	-40	-128	-28	-116	ps

[Derating Values of tIS/tIH (DDR2-667, DDR2-800)]

		CK, /CK Differential Slew Rate						Unit	Notes
		2.0 V/ns		1.5 V/ns		1.0 V/ns			
		Δt_{IS}	Δt_{IH}	Δt_{IS}	Δt_{IH}	Δt_{IS}	Δt_{IH}		
Command/address slew rate (V/ns)	4.0	+150	+94	+180	+124	+210	+154	ps	
	3.5	+143	+89	+173	+119	+203	+149	ps	
	3.0	+133	+83	+163	+113	+193	+143	ps	
	2.5	+120	+75	+150	+105	+180	+135	ps	
	2.0	+100	+45	+130	+75	+160	+105	ps	
	1.5	+67	+21	+97	+51	+127	+81	ps	
	1.0	0	0	+30	+30	+60	+60	ps	
	0.9	-5	-14	+25	+16	+55	+46	ps	
	0.8	-13	-31	+17	-1	+47	+29	ps	
	0.7	-22	-54	+8	-24	+38	+6	ps	
	0.6	-34	-83	-4	-53	+26	-23	ps	
	0.5	-60	-125	-30	-95	0	-65	ps	
	0.4	-100	-188	-70	-158	-40	-128	ps	
	0.3	-168	-292	-138	-262	-108	-232	ps	
	0.25	-200	-375	-170	-345	-140	-315	ps	
	0.2	-325	-500	-295	-470	-265	-440	ps	
	0.15	-517	-708	-487	-678	-457	-648	ps	
0.1	-1000	-1125	-970	-1095	-940	-1065	ps		

Single-ended DQS

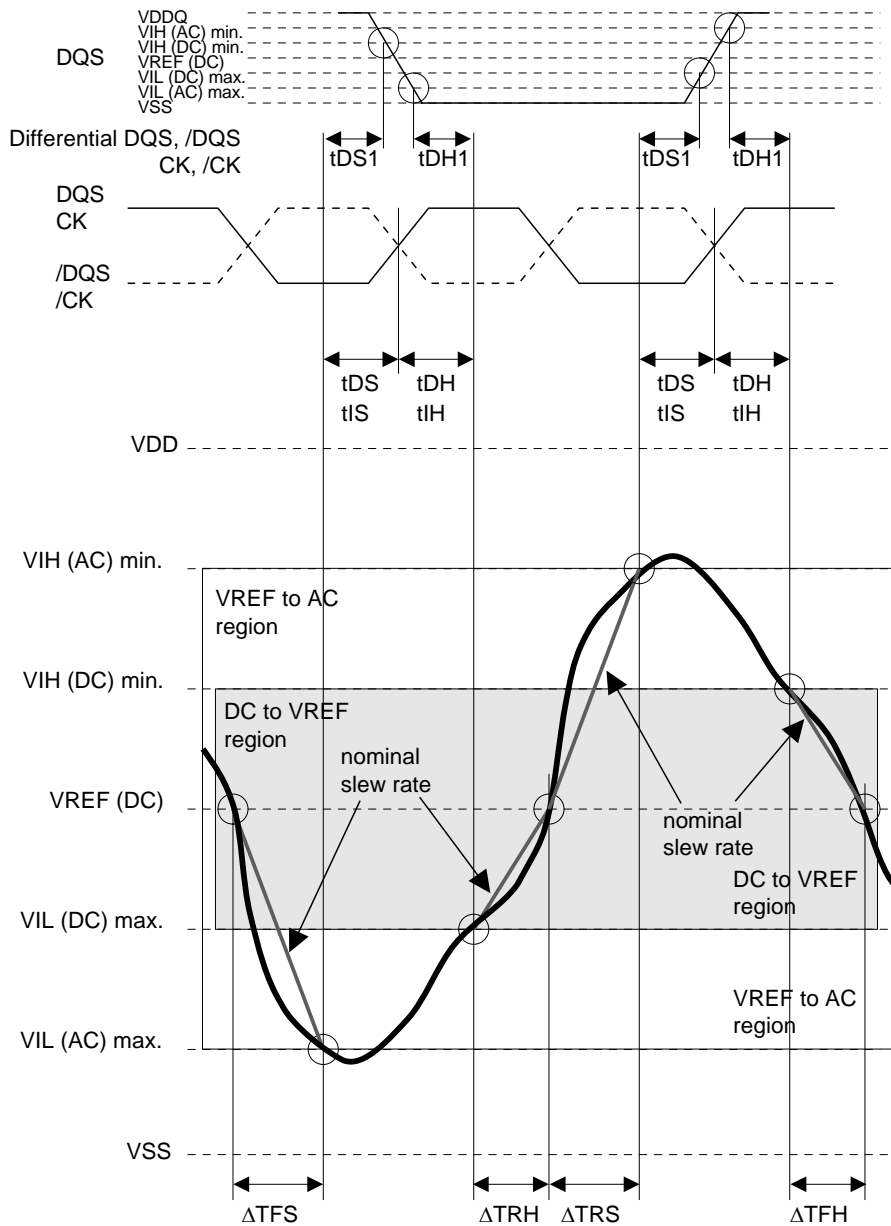

$$\text{Setup slew rate Falling signal} = \frac{VREF (DC) - VIL (AC) \text{ max.}}{\Delta TFS}$$

$$\text{Setup slew rate Rising signal} = \frac{VIH (AC) \text{ min.} - VREF (DC)}{\Delta TRS}$$

$$\text{Hold slew rate Rising signal} = \frac{VREF (DC) - VIL (DC) \text{ max.}}{\Delta TRH}$$

$$\text{Hold slew rate Falling signal} = \frac{VIH (DC) \text{ min.} - VREF (DC)}{\Delta TFH}$$

Slew Rate Definition Nominal

Single-ended DQS

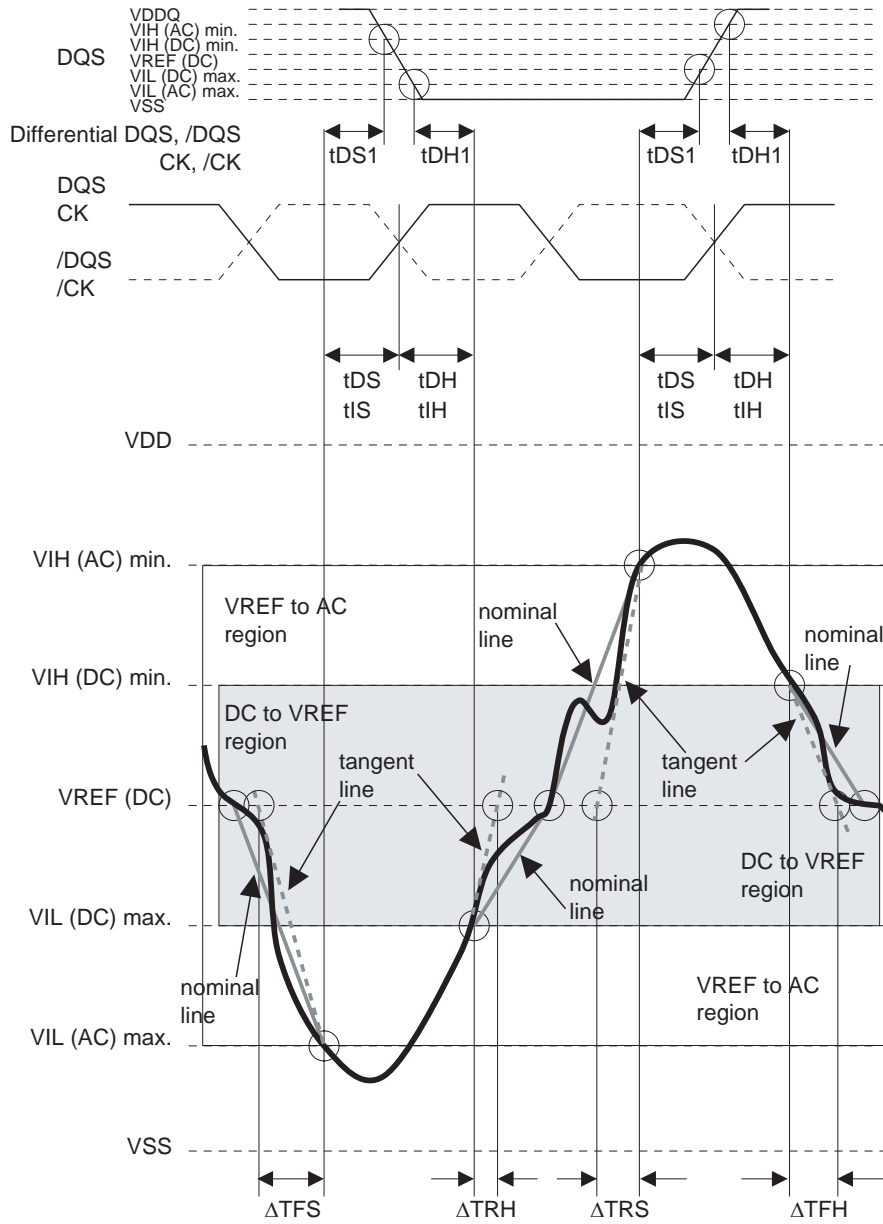

$$\text{Setup slew rate Falling signal} = \frac{\text{tangent line [VREF (DC) - VIL (AC) max.]}}{\Delta TFS}$$

$$\text{Setup slew rate Rising signal} = \frac{\text{tangent line [VIH (AC) min. - VREF (DC)]}}{\Delta TRS}$$

$$\text{Hold slew rate Rising signal} = \frac{\text{tangent line [VREF (DC) - VIL (DC) max.]}}{\Delta TRH}$$

$$\text{Hold slew rate Falling signal} = \frac{\text{tangent line [VIH (DC) min. - VREF (DC)]}}{\Delta TFH}$$

Slew Rate Definition Tangent

Block Diagram

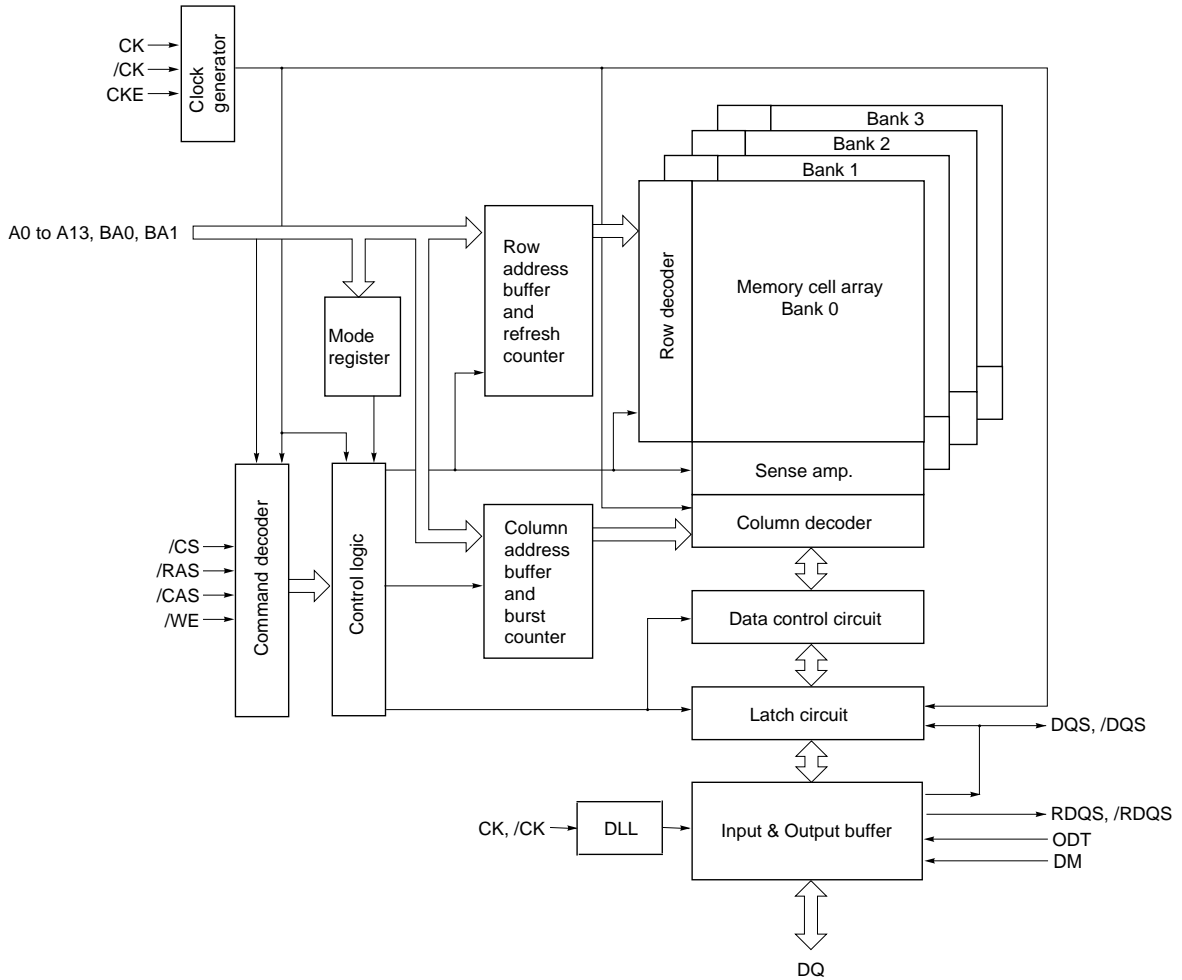

Pin Function

CK, /CK (input pins)

CK and /CK are differential clock inputs. All address and control input signals are sampled on the crossing of the positive edge of CK and negative edge of /CK. Output (read) data is referenced to the crossings of CK and /CK (both directions of crossing).

/CS (input pin)

All commands are masked when /CS is registered high. /CS provides for external rank selection on systems with multiple ranks. /CS is considered part of the command code.

/RAS, /CAS, /WE (input pins)

/RAS, /CAS and /WE (along with /CS) define the command being entered.

A0 to A13 (input pins)

Provided the row address for Active commands and the column address and Auto Precharge bit for Read/Write commands to select one location out of the memory array in the respective bank. The address inputs also provide the op-code during mode register set commands.

[Address Pins Table]

Part number	Address (A0 to A13)		Note
	Row address	Column address	
EDE5104AJSE	AX0 to AX13	AY0 to AY9, AY11	
EDE5108AJSE	AX0 to AX13	AY0 to AY9	
EDE5116AJSE	AX0 to AX12	AY0 to AY9	1

Note: 1. A13 pin is NC for × 16 organization.

A10 (AP) (input pin)

A10 is sampled during a precharge command to determine whether the precharge applies to one bank (A10 = low) or all banks (A10 = high). If only one bank is to be precharged, the bank is selected by BA0, BA1.

BA0, BA1 (input pins)

BA0 and BA1 define to which bank an active, read, write or precharge command is being applied. BA0 also determines if the mode register or extended mode register is to be accessed during a MRS or EMRS (1), EMRS (2) cycle.

[Bank Select Signal Table]

	BA0	BA1
Bank 0	L	L
Bank 1	H	L
Bank 2	L	H
Bank 3	H	H

Remark: H: VIH. L: VIL.

CKE (input pin)

CKE high activates, and CKE low deactivates, internal clock signals and device input buffers and output drivers. Taking CKE low provides precharge power-down and Self Refresh operation (all banks idle), or active power-down (row active in any bank). CKE is synchronous for power-down entry and exit, and for self-refresh entry. CKE is asynchronous for self-refresh exit. CKE must be maintained high throughout read and write accesses. Input buffers, excluding CK, /CK and CKE are disabled during power-down. Input buffers, excluding CKE, are disabled during self-refresh.

DM, UDM and LDM (input pins)

DM is an input mask signal for write data. Input data is masked when DM is sampled high coincident with that input data during a Write access. DM is sampled on both edges of DQS. Although DM pins are input only, the DM loading matches the DQ and DQS loading.

For ×8 configuration, DM function will be disabled when RDQS function is enabled by EMRS.

In ×16 configuration, UDM controls upper byte (DQ8 to DQ15) and LDM controls lower byte (DQ0 to DQ7). In this datasheet, DM represents UDM and LDM.

DQ (input/output pins)

Bi-directional data bus.

DQS, /DQS UDQS, /UDQS, LDQS, /LDQS (input/output pins)

Output with read data, input with write data for source synchronous operation. Edge-aligned with read data, centered in write data. Used to capture write data. /DQS can be disabled by EMRS.

In ×16 configuration, UDQS, /UDQS and LDQS, /LDQS control upper byte (DQ8 to DQ15) and lower byte (DQ0 to DQ7). In this datasheet, DQS represents UDQS and LDQS, /DQS represents /UDQS and /LDQS.

RDQS, /RDQS (output pins)

Differential Data Strobe for READ operation only. DM and RDQS functions are switch able by EMRS. These pins exist only in ×8 configuration. /RDQS output will be disabled when /DQS is disabled by EMRS.

ODT (input pins)

ODT (On Die Termination control) is a registered high signal that enables termination resistance internal to the DDR2 SDRAM. When enabled, ODT is only applied to each DQ, DQS, /DQS, RDQS, /RDQS and DM signal for ×4/×8 configurations. For ×16 configuration, ODT is applied to each DQ, UDQS, /UDQS, LDQS, /LDQS, UDM, and LDM signal. The ODT pin will be ignored if the Extended Mode Register (EMRS) is programmed to disable ODT. Any time the EMRS enables the ODT function; ODT may not be driven high until eight clocks after the EMRS has been enabled.

VDD, VSS, VDDQ, VSSQ (power supply)

VDD and VSS are power supply pins for internal circuits. VDDQ and VSSQ are power supply pins for the output buffers.

VDDL and VSSDL (power supply)

VDDL and VSSDL are power supply pins for DLL circuits.

VREF (Power supply)

SSTL_18 reference voltage: $(0.50 \pm 0.01) \times VDDQ$

Command Operation

Command Truth Table

The DDR2 SDRAM recognizes the following commands specified by the /CS, /RAS, /CAS, /WE and address pins.

Function	Symbol	CKE		/CS	/RAS	/CAS	/WE	BA0	BA1	A13 to A10		A9 to A0	Notes
		Previous cycle	Current cycle							A11	A10		
Mode register set	MRS	H	H	L	L	L	L	L	L	MRS OPCODE			1
Extended mode register set (1)	EMRS	H	H	L	L	L	L	H	L	EMRS (1) OPCODE			1
Extended mode register set (2)	EMRS	H	H	L	L	L	L	L	H	EMRS (2) OPCODE			1
Auto-refresh	REF	H	H	L	L	L	H	x	x	x	x	x	1
Self-refresh entry	SELF	H	L	L	L	L	H	x	x	x	x	x	1
Self-refresh exit	SELFEX	L	H	H	x	x	x	x	x	x	x	x	1, 6
		L	H	L	H	H	H	x	x	x	x	x	
Single bank precharge	PRE	H	H	L	L	H	L	BA		x	L	x	1, 2
Precharge all banks	PALL	H	H	L	L	H	L	x	x	x	H	x	1
Bank activate	ACT	H	H	L	L	H	H	BA		RA			1, 2
Write	WRIT	H	H	L	H	L	L	BA		CA	L	CA	1, 2, 3
Write with auto precharge	WRITA	H	H	L	H	L	L	BA		CA	H	CA	1, 2, 3
Read	READ	H	H	L	H	L	H	BA		CA	L	CA	1, 2, 3
Read with auto precharge	READA	H	H	L	H	L	H	BA		CA	H	CA	1, 2, 3
No operation	NOP	H	x	L	H	H	H	x	x	x	x	x	1
Device deselect	DESL	H	x	H	x	x	x	x	x	x	x	x	1
Power-down mode entry	PDEN	H	L	H	x	x	x	x	x	x	x	x	1, 4
		H	L	L	H	H	H	x	x	x	x	x	
Power-down mode exit	PDEX	L	H	H	x	x	x	x	x	x	x	x	1, 4
		L	H	L	H	H	H	x	x	x	x	x	

Remark: H = VIH. L = VIL. x = VIH or VIL. BA = Bank Address, RA = Row Address, CA = Column Address

- Notes:
- All DDR2 commands are defined by states of /CS, /RAS, /CAS, /WE and CKE at the rising edge of the clock.
 - Bank select (BA0, BA1), determine which bank is to be operated upon.
 - Burst reads or writes should not be terminated other than specified as "Reads interrupted by a Read" in burst read command [READ] or "Writes interrupted by a Write" in burst write command [WRIT].
 - The power-down mode does not perform any refresh operations. The duration of power-down is therefore limited by the refresh requirements of the device. One clock delay is required for mode entry and exit.
 - The state of ODT does not affect the states described in this table. The ODT function is not available during self-refresh.
 - Self-refresh exit is asynchronous.

CKE Truth Table

Current state*2	CKE		Command(n) ^{*3} /CS, /RAS, /CAS, /WE	Operation (n) ^{*3}	Notes
	Previous cycle (n-1)*1	Current cycle (n) ^{*1}			
Power-down	L	L	×	Maintain power-down	11, 13, 15
	L	H	DESL or NOP	Power-down exit	4, 8, 11, 13
Self-refresh	L	L	×	Maintain self-refresh	11, 15
	L	H	DESL or NOP	Self-refresh exit	4, 5, 9
Bank Active	H	L	DESL or NOP	Active power-down entry	4, 8, 10, 11, 13
All banks idle	H	L	DESL or NOP	Precharge power-down entry	4, 8, 10, 11, 13
	H	L	SELF	Self-refresh entry	6, 9, 11, 13
Any state other than listed above	H	H	Refer to the Command Truth Table		7

Remark: H = VIH. L = VIL. × = Don't care

- Notes: 1. CKE (n) is the logic state of CKE at clock edge n; CKE (n-1) was the state of CKE at the previous clock edge.
2. Current state is the state of the DDR SDRAM immediately prior to clock edge n.
 3. Command (n) is the command registered at clock edge n, and operation (n) is a result of Command (n).
 4. All states and sequences not shown are illegal or reserved unless explicitly described elsewhere in this document.
 5. On self-refresh exit, [DESL] or [NOP] commands must be issued on every clock edge occurring during the tXSNR period. Read commands may be issued only after tXSRD (200 clocks) is satisfied.
 6. Self-refresh mode can only be entered from the all banks idle state.
 7. Must be a legal command as defined in the command truth table.
 8. Valid commands for power-down entry and exit are [NOP] and [DESL] only.
 9. Valid commands for self-refresh exit are [NOP] and [DESL] only.
 10. Power-down and self-refresh can not be entered while read or write operations, (extended) mode register set operations or precharge operations are in progress. See section Power Down and Self Refresh Command for a detailed list of restrictions.
 11. Minimum CKE high time is 3 clocks; minimum CKE low time is 3 clocks.
 12. The state of ODT does not affect the states described in this table. The ODT function is not available during self-refresh. See section ODT (On Die Termination).
 13. The power-down does not perform any refresh operations. The duration of power-down mode is therefore limited by the refresh requirements outlined in section automatic refresh command.
 14. CKE must be maintained high while the SDRAM is in OCD calibration mode.
 15. "×" means "don't care" (including floating around VREF) in self-refresh and power-down. However ODT must be driven high or low in power-down if the ODT function is enabled (bit A2 or A6 set to "1" in EMRS(1)).

Function Truth Table

The following tables show the operations that are performed when each command is issued in each state of the DDR2 SDRAM.

Current state	/CS	/RAS	/CAS	/WE	Address	Command	Operation	Notes
Idle	H	x	x	x	x	DESL	Nop	
	L	H	H	H	x	NOP	Nop	
	L	H	L	H	BA, CA, A10 (AP)	READ/READA	ILLEGAL	1
	L	H	L	L	BA, CA, A10 (AP)	WRIT/WRITA	ILLEGAL	1
	L	L	H	H	BA, RA	ACT	Row activating	
	L	L	H	L	BA	PRE	Nop	
	L	L	H	L	A10 (AP)	PALL	Nop	
	L	L	L	H	x	REF	Auto-refresh	2
	L	L	L	H	x	SELF	Self refresh	2
	L	L	L	L	BA, MRS-OPCODE	MRS	Mode register accessing	2
	L	L	L	L	BA, EMRS-OPCODE	EMRS (1) (2)	Extended mode register accessing	2
	Bank(s) active	H	x	x	x	x	DESL	Nop
L		H	H	H	x	NOP	Nop	
L		H	L	H	BA, CA, A10 (AP)	READ/READA	Begin Read	
L		H	L	L	BA, CA, A10 (AP)	WRIT/WRITA	Begin Write	
L		L	H	H	BA, RA	ACT	ILLEGAL	1
L		L	H	L	BA	PRE	Precharge	
L		L	H	L	A10 (AP)	PALL	Precharge all banks	
L		L	L	H	x	REF	ILLEGAL	
L		L	L	H	x	SELF	ILLEGAL	
L		L	L	L	BA, MRS-OPCODE	MRS	ILLEGAL	
L		L	L	L	BA, EMRS-OPCODE	EMRS (1) (2)	ILLEGAL	
Read		H	x	x	x	x	DESL	Continue burst to end -> Row active
	L	H	H	H	x	NOP	Continue burst to end -> Row active	
	L	H	L	H	BA, CA, A10 (AP)	READ/READA	Burst interrupt	1, 4
	L	H	L	L	BA, CA, A10 (AP)	WRIT/WRITA	ILLEGAL	1
	L	L	H	H	BA, RA	ACT	ILLEGAL	1
	L	L	H	L	BA	PRE	ILLEGAL	1, 8
	L	L	H	L	A10 (AP)	PALL	ILLEGAL	8
	L	L	L	H	x	REF	ILLEGAL	
	L	L	L	H	x	SELF	ILLEGAL	
	L	L	L	L	BA, MRS-OPCODE	MRS	ILLEGAL	
	L	L	L	L	BA, EMRS-OPCODE	EMRS (1) (2)	ILLEGAL	

Current state	/CS	/RAS	/CAS	/WE	Address	Command	Operation	Note
Write	H	x	x	x	x	DESL	Continue burst to end -> Write recovering	
	L	H	H	H	x	NOP	Continue burst to end -> Write recovering	
	L	H	L	H	BA, CA, A10 (AP)	READ/READA	ILLEGAL	1
	L	H	L	L	BA, CA, A10 (AP)	WRIT/WRITA	Burst interrupt	1, 4
	L	L	H	H	BA, RA	ACT	ILLEGAL	1
	L	L	H	L	BA	PRE	ILLEGAL	1, 8
	L	L	H	L	A10 (AP)	PALL	ILLEGAL	8
	L	L	L	H	x	REF	ILLEGAL	
	L	L	L	H	x	SELF	ILLEGAL	
	L	L	L	L	BA, MRS-OPCODE	MRS	ILLEGAL	
Read with auto precharge	L	L	L	L	BA, EMRS-OPCODE	EMRS (1) (2)	ILLEGAL	
	H	x	x	x	x	DESL	Continue burst to end -> Precharging	
	L	H	H	H	x	NOP	Continue burst to end -> Precharging	
	L	H	L	H	BA, CA, A10 (AP)	READ/READA	ILLEGAL	1, 7
	L	H	L	L	BA, CA, A10 (AP)	WRIT/WRITA	ILLEGAL	1, 7
	L	L	H	H	BA, RA	ACT	ILLEGAL	1, 7
	L	L	H	L	BA	PRE	ILLEGAL	1, 7, 8
	L	L	H	L	A10 (AP)	PALL	ILLEGAL	7, 8
	L	L	L	H	x	REF	ILLEGAL	
	L	L	L	H	x	SELF	ILLEGAL	
Write with auto Precharge	L	L	L	L	BA, MRS-OPCODE	MRS	ILLEGAL	
	L	L	L	L	BA, EMRS-OPCODE	EMRS (1) (2)	ILLEGAL	
	H	x	x	x	x	DESL	Continue burst to end ->Write recovering with auto precharge	
	L	H	H	H	x	NOP	Continue burst to end ->Write recovering with auto precharge	
	L	H	L	H	BA, CA, A10 (AP)	READ/READA	ILLEGAL	1, 7
	L	H	L	L	BA, CA, A10 (AP)	WRIT/WRITA	ILLEGAL	1, 7
	L	L	H	H	BA, RA	ACT	ILLEGAL	1, 7
	L	L	H	L	BA	PRE	ILLEGAL	1, 7, 8
	L	L	H	L	A10 (AP)	PALL	ILLEGAL	7, 8
	L	L	L	H	x	REF	ILLEGAL	
L	L	L	H	x	SELF	ILLEGAL		
L	L	L	L	BA, MRS-OPCODE	MRS	ILLEGAL		
L	L	L	L	BA, EMRS-OPCODE	EMRS (1) (2)	ILLEGAL		

Current state	/CS	/RAS	/CAS	/WE	Address	Command	Operation	Note
Precharging	H	x	x	x	x	DESL	Nop -> Enter idle after tRP	
	L	H	H	H	x	NOP	Nop -> Enter idle after tRP	
	L	H	L	H	BA, CA, A10 (AP)	READ/READA	ILLEGAL	1
	L	H	L	L	BA, CA, A10 (AP)	WRIT/WRITA	ILLEGAL	1
	L	L	H	H	BA, RA	ACT	ILLEGAL	1
	L	L	H	L	BA	PRE	Nop -> Enter idle after tRP	
	L	L	H	L	A10 (AP)	PALL	Nop -> Enter idle after tRP	
	L	L	L	H	x	REF	ILLEGAL	
	L	L	L	H	x	SELF	ILLEGAL	
	L	L	L	L	BA, MRS-OPCODE	MRS	ILLEGAL	
L	L	L	L	BA, EMRS-OPCODE	EMRS (1) (2)	ILLEGAL		
Row activating	H	x	x	x	x	DESL	Nop -> Enter bank active after tRCD	
	L	H	H	H	x	NOP	Nop -> Enter bank active after tRCD	
	L	H	L	H	BA, CA, A10 (AP)	READ/READA	ILLEGAL	1, 5
	L	H	L	L	BA, CA, A10 (AP)	WRIT/WRITA	ILLEGAL	1, 5
	L	L	H	H	BA, RA	ACT	ILLEGAL	1
	L	L	H	L	BA	PRE	ILLEGAL	
	L	L	H	L	A10 (AP)	PALL	ILLEGAL	
	L	L	L	H	x	REF	ILLEGAL	
	L	L	L	H	x	SELF	ILLEGAL	
	L	L	L	L	BA, MRS-OPCODE	MRS	ILLEGAL	
L	L	L	L	BA, EMRS-OPCODE	EMRS (1) (2)	ILLEGAL		
Write recovering	H	x	x	x	x	DESL	Nop -> Enter bank active after tWR	
	L	H	H	H	x	NOP	Nop -> Enter bank active after tWR	
	L	H	L	H	BA, CA, A10 (AP)	READ/READA	ILLEGAL	1, 6
	L	H	L	L	BA, CA, A10 (AP)	WRIT/WRITA	New write	
	L	L	H	H	BA, RA	ACT	ILLEGAL	1
	L	L	H	L	BA	PRE	ILLEGAL	1
	L	L	H	L	A10 (AP)	PALL	ILLEGAL	
	L	L	L	H	x	REF	ILLEGAL	
	L	L	L	H	x	SELF	ILLEGAL	
	L	L	L	L	BA, MRS-OPCODE	MRS	ILLEGAL	
L	L	L	L	BA, EMRS-OPCODE	EMRS (1) (2)	ILLEGAL		

Current state	/CS	/RAS	/CAS	/WE	Address	Command	Operation	Note
Write recovering with auto precharge	H	×	×	×	×	DESL	Nop -> Precharging after tWR	
	L	H	H	H	×	NOP	Nop -> Precharging after tWR	
	L	H	L	H	BA, CA, A10 (AP)	READ/READA	ILLEGAL	1
	L	H	L	L	BA, CA, A10 (AP)	WRIT/WRITA	ILLEGAL	1
	L	L	H	H	BA, RA	ACT	ILLEGAL	1
	L	L	H	L	BA	PRE	ILLEGAL	1
	L	L	H	L	A10 (AP)	PALL	ILLEGAL	
	L	L	L	H	×	REF	ILLEGAL	
	L	L	L	H	×	SELF	ILLEGAL	
	L	L	L	L	BA, MRS-OPCODE	MRS	ILLEGAL	
L	L	L	L	BA, EMRS-OPCODE	EMRS (1) (2)	ILLEGAL		
Refresh	H	×	×	×	×	DESL	Nop -> Enter idle after tRFC	
	L	H	H	H	×	NOP	Nop -> Enter idle after tRFC	
	L	H	L	H	BA, CA, A10 (AP)	READ/READA	ILLEGAL	
	L	H	L	L	BA, CA, A10 (AP)	WRIT/WRITA	ILLEGAL	
	L	L	H	H	BA, RA	ACT	ILLEGAL	
	L	L	H	L	BA	PRE	ILLEGAL	
	L	L	H	L	A10 (AP)	PALL	ILLEGAL	
	L	L	L	H	×	REF	ILLEGAL	
	L	L	L	H	×	SELF	ILLEGAL	
	L	L	L	L	BA, MRS-OPCODE	MRS	ILLEGAL	
L	L	L	L	BA, EMRS-OPCODE	EMRS (1) (2)	ILLEGAL		
Mode register accessing	H	×	×	×	×	DESL	Nop -> Enter idle after tMRD	
	L	H	H	H	×	NOP	Nop -> Enter idle after tMRD	
	L	H	L	H	BA, CA, A10 (AP)	READ/READA	ILLEGAL	
	L	H	L	L	BA, CA, A10 (AP)	WRIT/WRITA	ILLEGAL	
	L	L	H	H	BA, RA	ACT	ILLEGAL	
	L	L	H	L	BA	PRE	ILLEGAL	
	L	L	H	L	A10 (AP)	PALL	ILLEGAL	
	L	L	L	H	×	REF	ILLEGAL	
	L	L	L	H	×	SELF	ILLEGAL	
	L	L	L	L	BA, MRS-OPCODE	MRS	ILLEGAL	
L	L	L	L	BA, EMRS-OPCODE	EMRS (1) (2)	ILLEGAL		

Current state	/CS	/RAS	/CAS	/WE	Address	Command	Operation	Note
Extended Mode	H	×	×	×	×	DESL	Nop -> Enter idle after tMRD	
register accessing	L	H	H	H	×	NOP	Nop -> Enter idle after tMRD	
	L	H	L	H	BA, CA, A10 (AP)	READ/READA	ILLEGAL	
	L	H	L	L	BA, CA, A10 (AP)	WRIT/WRITA	ILLEGAL	
	L	L	H	H	BA, RA	ACT	ILLEGAL	
	L	L	H	L	BA	PRE	ILLEGAL	
	L	L	H	L	A10 (AP)	PALL	ILLEGAL	
	L	L	L	H	×	REF	ILLEGAL	
	L	L	L	H	×	SELF	ILLEGAL	
	L	L	L	L	BA, MRS-OPCODE	MRS	ILLEGAL	
	L	L	L	L	BA, EMRS-OPCODE	EMRS (1) (2)	ILLEGAL	

Remark: H = VIH. L = VIL. × = VIH or VIL

Notes: 1. This command may be issued for other banks, depending on the state of the banks.

2. All banks must be in "IDLE".
3. All AC timing specs must be met.
4. Only allowed at the boundary of 4 bits burst. Burst interruptions at other timings are illegal.
5. Available in case tRCD is satisfied by AL setting.
6. Available in case tWTR is satisfied.
7. The DDR2 SDRAM supports the concurrent auto-precharge feature, a read with auto-precharge enabled, or a write with auto-precharge enabled, may be followed by any column command to other banks, as long as that command does not interrupt the read or write data transfer, and all other related limitations apply. (E.g. Conflict between READ data and WRITE data must be avoided.)

The minimum delay from a read or write command with auto precharge enabled, to a command to a different bank, is summarized below.

From command	To command (different bank, non-interrupting command)	Minimum delay (Concurrent AP supported)	Units
Read w/AP	Read or Read w/AP	BL/2	tCK
	Write or Write w/AP	(BL/2) + 2	tCK
	Precharge or Activate	1	tCK
Write w/AP	Read or Read w/AP	(CL - 1) + (BL/2) + tWTR	tCK
	Write or Write w/AP	BL/2	tCK
	Precharge or Activate	1	tCK

8. The minimum delay from the read, write and precharge command to the precharge command to the same bank is summarized below.

[Precharge and Auto Precharge Clarification]

From command	To command	Minimum delay between "From command" to "To Command"	Units	Notes
Read	Precharge (to same bank as read)	$AL + (BL/2) + \text{Max.}(RTP, 2) - 2$	tCK	a, b
	Precharge all	$AL + (BL/2) + \text{Max.}(RTP, 2) - 2$	tCK	a, b
Read w/AP	Precharge (to same bank as read w/AP)	$AL + (BL/2) + \text{Max.}(RTP, 2) - 2$	tCK	a, b
	Precharge all	$AL + (BL/2) + \text{Max.}(RTP, 2) - 2$	tCK	a, b
Write	Precharge (to same bank as write)	$WL + (BL/2) + tWR$	tCK	b
	Precharge all	$WL + (BL/2) + tWR$	tCK	b
Write w/AP	Precharge (to same bank as write w/AP)	$WL + (BL/2) + WR$	tCK	b
	Precharge all	$WL + (BL/2) + WR$	tCK	b
Precharge	Precharge (to same bank as precharge)	1	tCK	b
	Precharge all	1	tCK	b
Precharge all	Precharge	1	tCK	b
	Precharge all	1	tCK	b

- a. $RTP[\text{cycles}] = RU\{ tRTP[\text{ns}] / tCK[\text{ns}] \}$, where RU stands for round up.
tCK(avg) should be used in place of tCK for DDR2-667/800.
- b. For a given bank, the precharge period should be counted from the latest precharge command, either one bank precharge or precharge all, issued to that bank. The precharge period is satisfied after tRP depending on the latest precharge command issued to that bank.

Simplified State Diagram

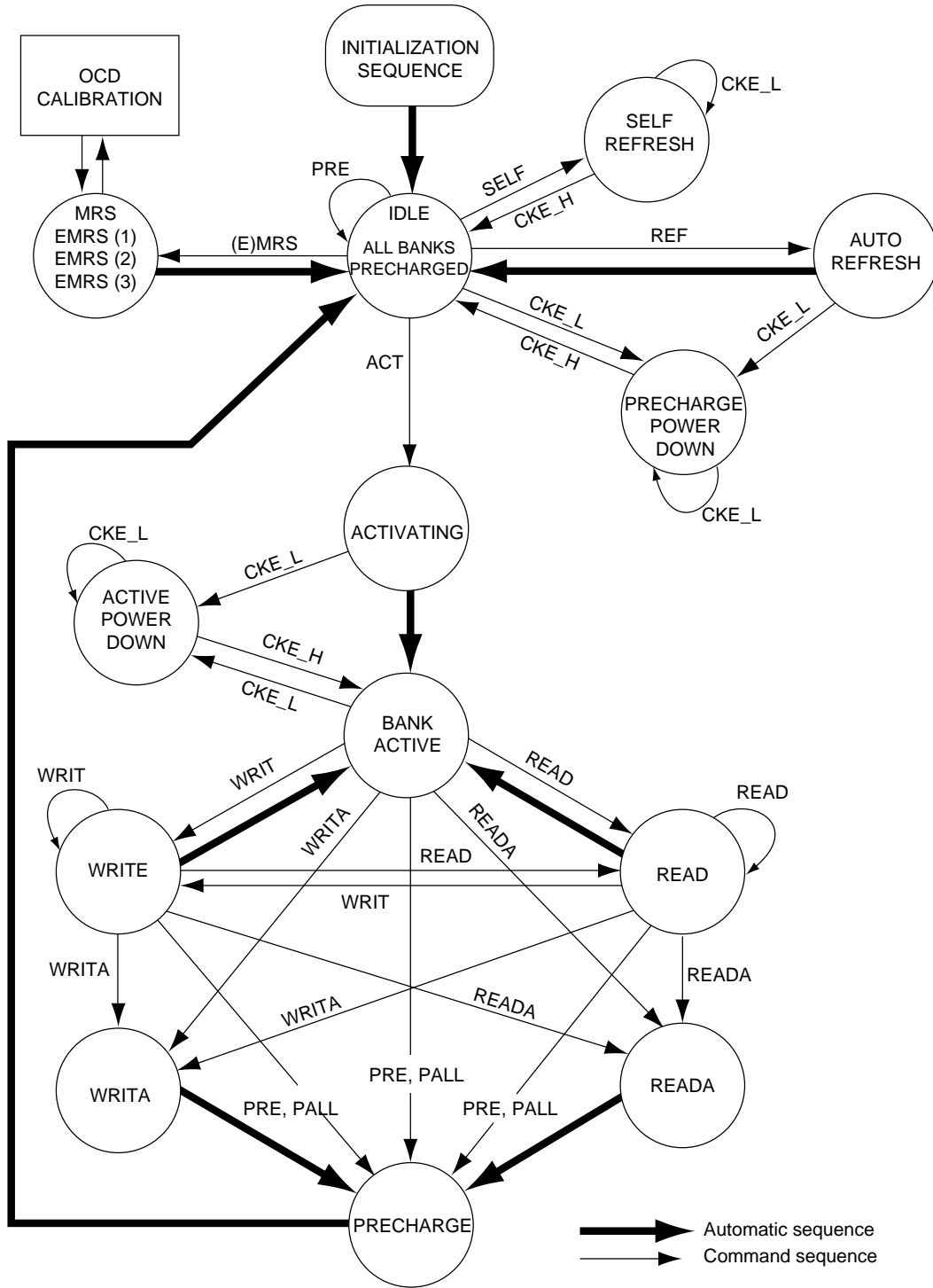

Simplified State Diagram

Operation of DDR2 SDRAM

Read and write accesses to the DDR2 SDRAM are burst oriented; accesses start at a selected location and continue for the fixed burst length of four or eight in a programmed sequence. Accesses begin with the registration of an active command, which is then followed by a read or write command. The address bits registered coincident with the active command is used to select the bank and row to be accessed (BA0, BA1 select the bank; A0 to A13 select the row). The address bits registered coincident with the read or write command are used to select the starting column location for the burst access and to determine if the auto precharge command is to be issued.

Prior to normal operation, the DDR2 SDRAM must be initialized. The following sections provide detailed information covering device initialization; register definition, command descriptions and device operation.

Power On and Initialization

DDR2 SDRAMs must be powered up and initialized in a predefined manner. Operational procedures other than those specified may result in undefined operation.

Power-Up and Initialization Sequence

The following sequence is required for power up and initialization.

1. Apply power and attempt to maintain CKE below $0.2 \times VDDQ$ and ODT *1 at a low state (all other inputs may be undefined.)
 - VDD, VDDL and VDDQ are driven from a single power converter output, AND
 - VTT is limited to 0.95V max, AND
 - VREF tracks VDDQ/2.
 or
 - Apply VDD before or at the same time as VDDL.
 - Apply VDDL before or at the same time as VDDQ.
 - Apply VDDQ before or at the same time as VTT and VREF.
 at least one of these two sets of conditions must be met.
2. Start clock and maintain stable condition.
3. For the minimum of 200µs after stable power and clock (CK, /CK), then apply [NOP] or [DESL] and take CKE high.
4. Wait minimum of 400ns then issue precharge all command. [NOP] or [DESL] applied during 400ns period.
5. Issue EMRS (2) command. (To issue EMRS (2) command, provide low to BA0, high to BA1.)
6. Issue EMRS (3) command. (To issue EMRS (3) command, high to BA0 and BA1.)
7. Issue EMRS to enable DLL. (To issue DLL enable command, provide low to A0, high to BA0 and low to BA1 and A13.)
8. Issue a mode register set command for DLL reset. (To issue DLL reset command, provide high to A8 and low to BA0, BA1 and A13.)
9. Issue precharge all command.
10. Issue 2 or more auto-refresh commands.
11. Issue a mode register set command with low to A8 to initialize device operation. (i.e. to program operating parameters without resetting the DLL.)
12. At least 200 clocks after step 8, execute OCD calibration (Off Chip Driver impedance adjustment). If OCD calibration is not used, EMRS OCD default command (A9 = A8 = A7 = 1) followed by EMRS OCD calibration mode exit command (A9 = A8 = A7 = 0) must be issued with other operating parameters of EMRS.
13. The DDR2 SDRAM is now ready for normal operation.

Note: 1. To guarantee ODT off, VREF must be valid and a low level must be applied to the ODT pin.

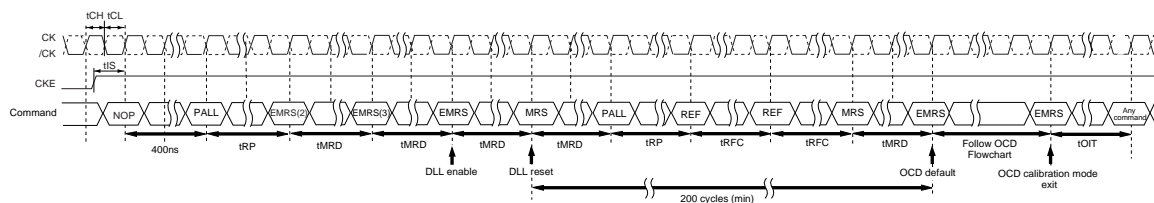

Power up and Initialization Sequence

Programming the Mode Register and Extended Mode Registers

For application flexibility, burst length, burst type, /CAS latency, DLL reset function, write recovery time (tWR) are user defined variables and must be programmed with a mode register set command [MRS]. Additionally, DLL disable function, driver impedance, additive /CAS latency, ODT (On Die Termination), single-ended strobe, and OCD (Off-Chip Driver Impedance Adjustment) are also user defined variables and must be programmed with an extended mode register set command [EMRS]. Contents of the Mode Register (MR) or Extended Mode Registers (EMR (#)) can be altered by reexecuting the MRS and EMRS commands. If the user chooses to modify only a subset of the MRS or EMRS variables, all variables must be redefined when the MRS or EMRS commands are issued.

MRS, EMRS and Reset DLL do not affect array contents, which means reinitialization including those can be executed any time after power-up without affecting array contents.

DDR2 SDRAM Mode Register Set [MRS]

The mode register stores the data for controlling the various operating modes of DDR2 SDRAM. It controls /CAS latency, burst length, burst sequence, test mode, DLL reset, tWR and various vendor specific options to make DDR2 SDRAM useful for various applications. The default value of the mode register is not defined, therefore the mode register must be written after power-up for proper operation. The mode register is written by asserting low on /CS, /RAS, /CAS, /WE, BA0 and BA1, while controlling the state of address pins A0 to A13.

The DDR2 SDRAM should be in all bank precharge with CKE already high prior to writing into the mode register. The mode register set command cycle time (tMRD) is required to complete the write operation to the mode register. The mode register contents can be changed using the same command and clock cycle requirements during normal operation as long as all banks are in the precharge state. The mode register is divided into various fields depending on functionality. Burst length is defined by A0 to A2 with options of 4 and 8 bit burst lengths. The burst length decodes are compatible with DDR SDRAM. Burst address sequence type is defined by A3, /CAS latency is defined by A4 to A6. The DDR2 doesn't support half clock latency mode. A7 is used for test mode. A8 is used for DLL reset. A7 must be set to low for normal MRS operation. Write recovery time tWR is defined by A9 to A11. Refer to the table for specific codes.

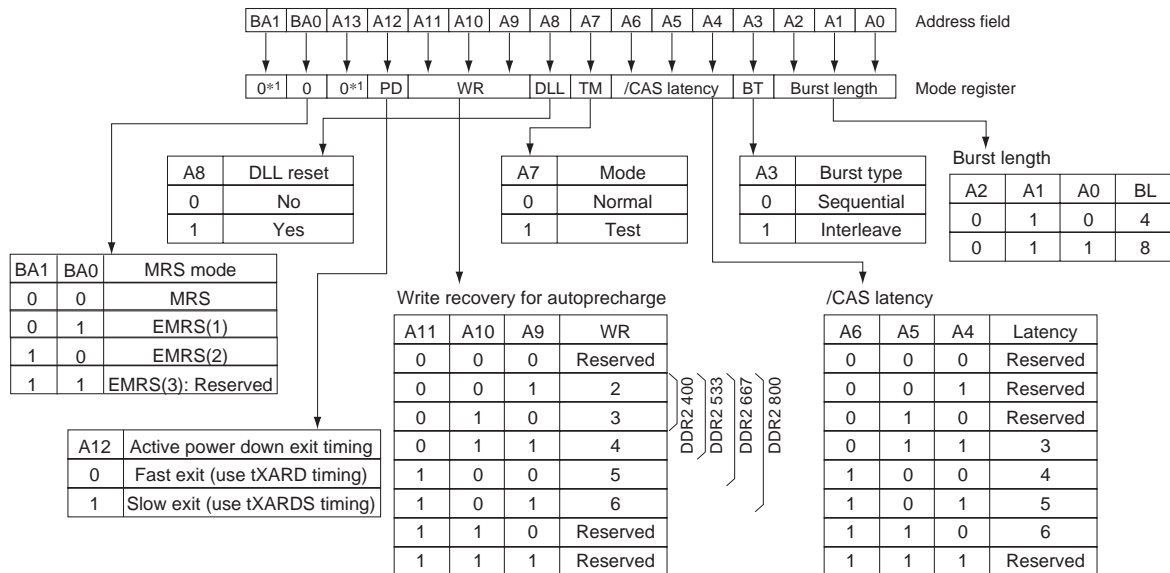

- Notes: 1. BA1 and A13 are reserved for future use and must be programmed to 0 when setting the mode register.
 2. WR (min.) (Write Recovery for autoprecharge) is determined by tCK (max.) and WR (max.) is determined by tCK (min.).
 WR in clock cycles is calculated by dividing tWR (in ns) by tCK (in ns) and rounding up to the next integer
 (WR [cycles] = tWR (ns) / tCK (ns)).
 The mode register must be programmed to this value. This is also used with tRP to determine tDAL.

Mode Register Set (MRS)

DDR2 SDRAM Extended Mode Registers Set [EMRS]

EMRS (1) Programming

The extended mode register (1) stores the data for enabling or disabling the DLL, output driver strength, additive latency, ODT, /DQS disable, OCD program, RDQS enable. The default value of the extended mode register (1) is not defined, therefore the extended mode register (1) must be written after power-up for proper operation. The extended mode register (1) is written by asserting low on /CS, /RAS, /CAS, /WE, high on BA0 and low on BA1, while controlling the states of address pins A0 to A13. The DDR2 SDRAM should be in all banks precharge with CKE already high prior to writing into the extended mode register (1). The mode register set command cycle time (tMRD) must be satisfied to complete the write operation to the extended mode register (1). Mode register contents can be changed using the same command and clock cycle requirements during normal operation as long as all banks are in the precharge state. A0 is used for DLL enable or disable. A1 is used for enabling a half strength output driver. A3 to A5 determines the additive latency, A7 to A9 are used for OCD control, A10 is used for /DQS disable and A11 is used for RDQS enable. A2 and A6 are used for ODT setting.

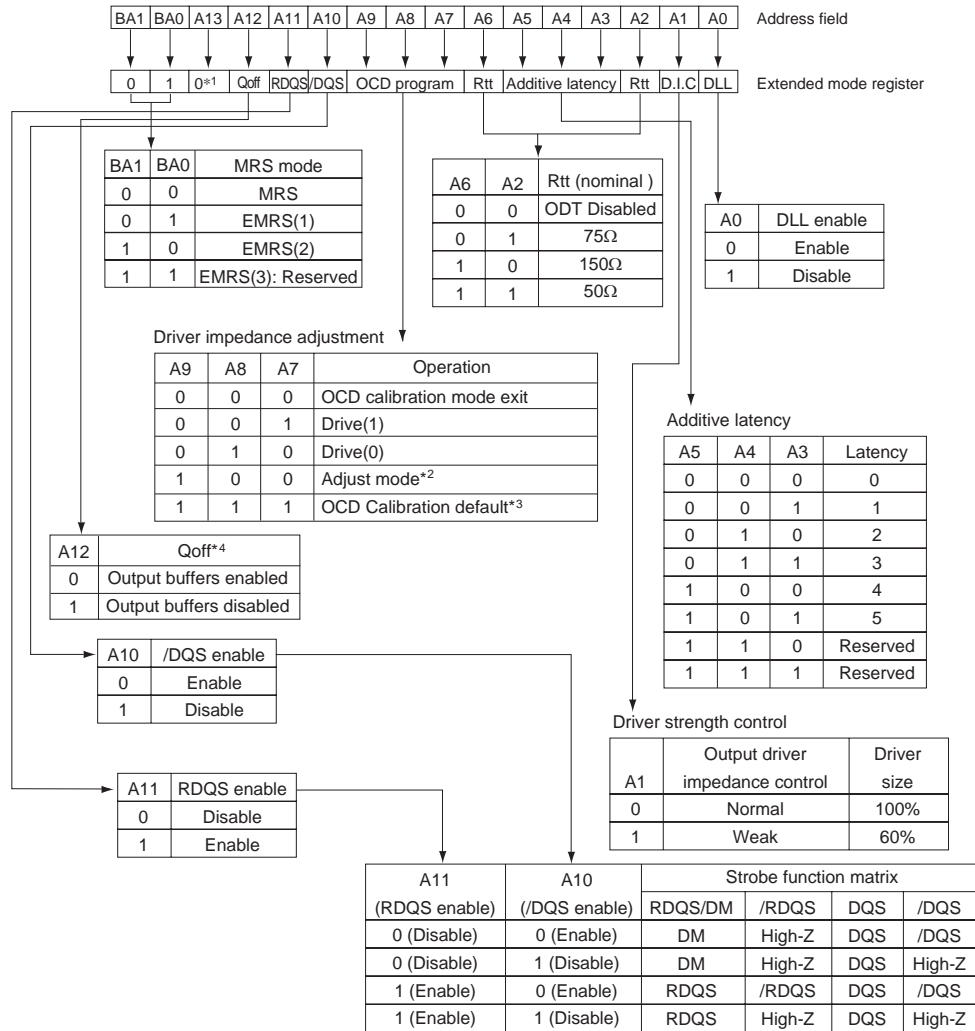

- Notes: 1. A13 is reserved for future use, and must be programmed to 0 when setting the extended mode register.
 2. When adjust mode is issued, AL from previously set value must be applied.
 3. After setting to default, OCD mode needs to be exited by setting A9 to A7 to 000. Refer to the chapter Off-Chip Driver (OCD) Impedance Adjustment for detailed information.
 4. Output disabled - DQ, DQS, /DQS, RDQS, /RDQS. This feature is used in conjunction with DIMM IDD measurements when IDDQ is not desired to be included.

EMRS (1)

DLL Enable/Disable

The DLL must be enabled for normal operation. DLL enable is required during power up initialization, and upon returning to normal operation after having the DLL disabled. The DLL is automatically disabled when entering self-refresh operation and is automatically re-enabled upon exit of self-refresh operation. Any time the DLL is enabled (and subsequently reset), 200 clock cycles must occur before a read command can be issued to allow time for the internal clock to be synchronized with the external clock. Failing to wait for synchronization to occur may result in a violation of the tAC or tDQSK parameters.

EMRS (2) Programming¹

The extended mode register (2) controls refresh related features. The default value of the extended mode register (2) is not defined, therefore the extended mode register (2) must be written after power-up for proper operation. The extended mode register (2) is written by asserting low on CS, /RAS, /CAS, /WE, high on BA1 and low on BA0, while controlling the states of address pins A0 to A13. The DDR2 SDRAM should be in all bank precharge with CKE already high prior to writing into the extended mode register (2). The mode register set command cycle time (tMRD) must be satisfied to complete the write operation to the extended mode register (2). Mode register contents can be changed using the same command and clock cycle requirements during normal operation as long as all banks are in the precharge state.

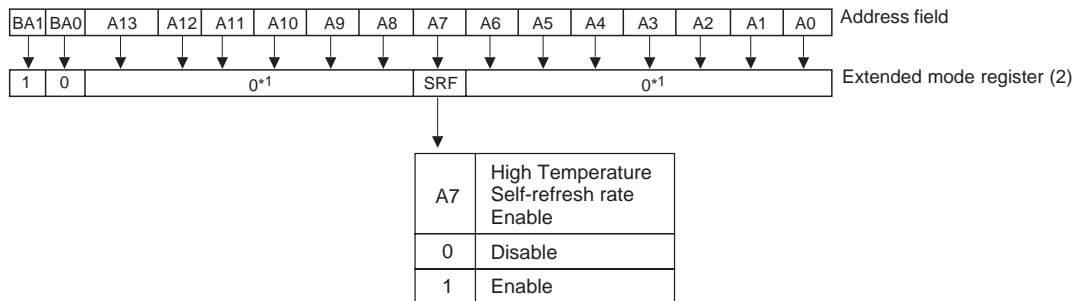

Note: 1 The rest bits in EMRS (2) is reserved for future use and all bits in EMRS (2) except A7, BA0 and BA1 must be programmed to 0 when setting the extended mode register (2) during initialization.

EMRS(2)

EMRS (3) Programming: Reserved¹

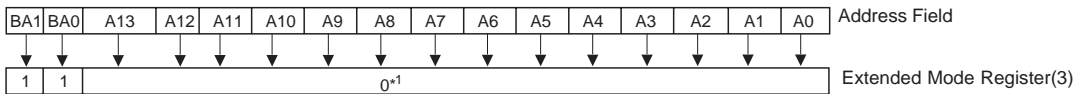

Note : 1. EMRS (3) is reserved for future use and all bits except BA0 and BA1 must be programmed to 0 when setting the mode register during initialization.

EMRS (3)

Off-Chip Driver (OCD) Impedance Adjustment

DDR2 SDRAM supports driver calibration feature and the OCD Flow Chart is an example of sequence. Every calibration mode command should be followed by "OCD calibration mode exit" before any other command being issued. MRS should be set before entering OCD impedance adjustment and ODT (On Die Termination) should be carefully controlled depending on system environment.

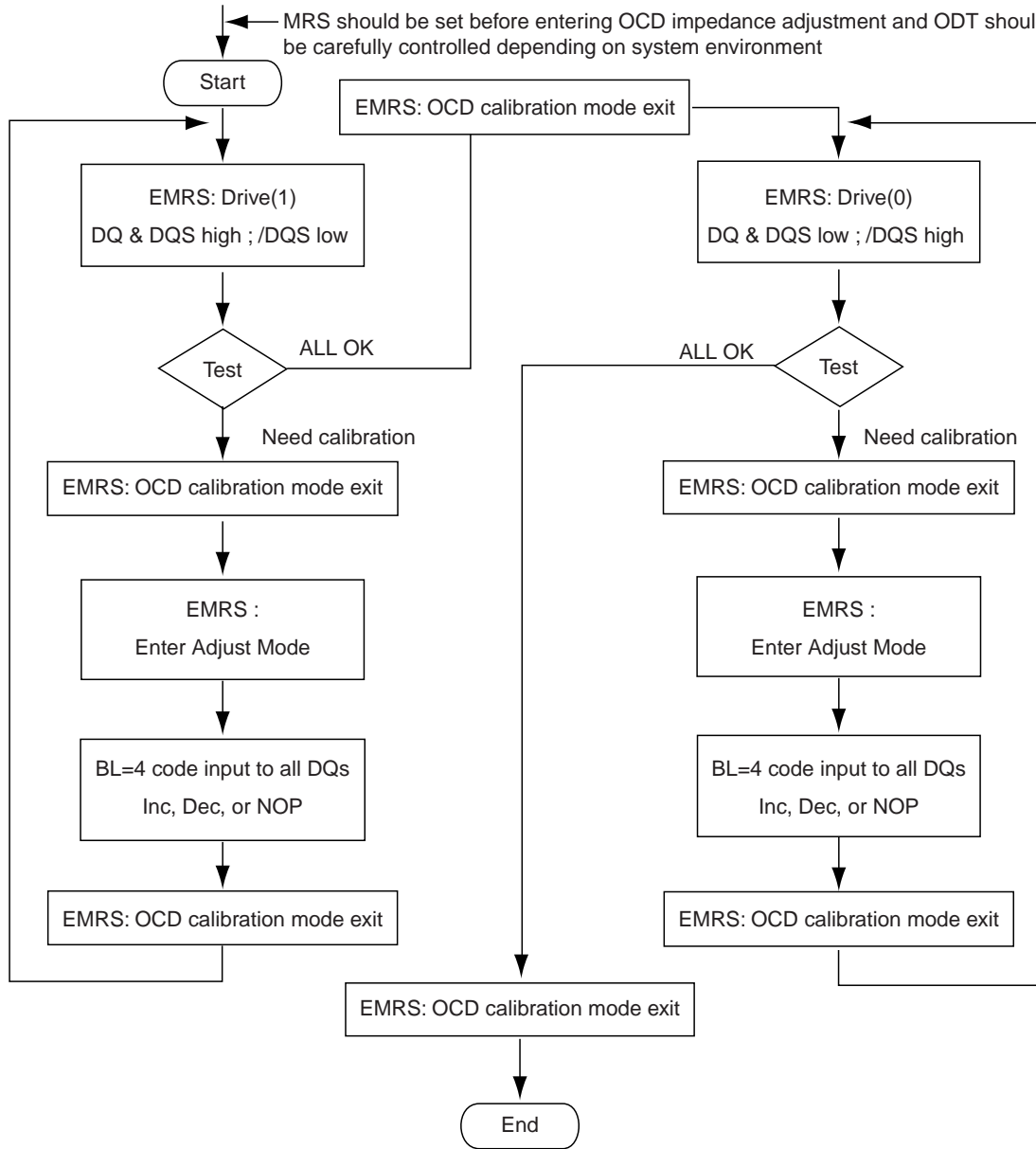

OCD Flow Chart

Extended Mode Register Set for OCD Impedance Adjustment

OCD impedance adjustment can be done using the following EMRS mode. In drive mode all outputs are driven out by DDR2 SDRAM and drive of RDQS is dependent on EMRS bit enabling RDQS operation. In Drive (1) mode, all DQ, DQS (and RDQS) signals are driven high and all /DQS signals are driven low. In drive (0) mode, all DQ, DQS (and RDQS) signals are driven low and all /DQS signals are driven high.

In adjust mode, BL = 4 of operation code data must be used. In case of OCD calibration default, output driver characteristics follow approximate nominal V/I curve for 18Ω output drivers, but are not guaranteed. If tighter control is required, which is controlled within 18Ω ± 3Ω driver impedance range, OCD must be used.

OCD applies only to normal full strength output drive setting defined by EMRS (1) and if reduced strength is set, OCD default output driver characteristics are not applicable. When OCD calibration adjust mode is used, OCD default output driver characteristics are not applicable.

[OCD Mode Set Program]

A9	A8	A7	Operation
0	0	0	OCD calibration mode exit
0	0	1	Drive (1) DQ, DQS, (RDQS) high and /DQS low
0	1	0	Drive (0) DQ, DQS, (RDQS) low and /DQS high
1	0	0	Adjust mode
1	1	1	OCD calibration default

OCD Impedance Adjustment

To adjust output driver impedance, controllers must issue the ADJUST EMRS command along with a 4bit burst code to DDR2 SDRAM as in OCD Adjustment Program table. For this operation, burst length has to be set to BL = 4 via MRS command before activating OCD and controllers must drive this burst code to all DQs at the same time. DT0 in OCD Adjustment Program table means all DQ bits at bit time 0, DT1 at bit time 1, and so forth. The driver output impedance is adjusted for all DDR2 SDRAM DQs simultaneously and after OCD calibration, all DQs and DQS's of a given DDR2 SDRAM will be adjusted to the same driver strength setting. The maximum step count for adjustment is 16 and when the limit is reached, further increment or decrement code has no effect. The default setting may be any step within the 16-step range. When Adjust mode command is issued, AL from previously set value must be applied.

[OCD Adjustment Program]

4bits burst data inputs to all DQs				Operation	
DT0	DT1	DT2	DT3	Pull-up driver strength	Pull-down driver strength
0	0	0	0	NOP	NOP
0	0	0	1	Increase by 1 step	NOP
0	0	1	0	Decrease by 1 step	NOP
0	1	0	0	NOP	Increase by 1 step
1	0	0	0	NOP	Decrease by 1 step
0	1	0	1	Increase by 1 step	Increase by 1 step
0	1	1	0	Decrease by 1 step	Increase by 1 step
1	0	0	1	Increase by 1 step	Decrease by 1 step
1	0	1	0	Decrease by 1 step	Decrease by 1 step
Other combinations				Reserved	

For proper operation of adjust mode, $WL = RL - 1 = AL + CL - 1$ clocks and tDS/tDH should be met as the Output Impedance Control Register Set Cycle. For input data pattern for adjustment, DT0 to DT3 is a fixed order and not affected by MRS addressing mode (i.e. sequential or interleave).

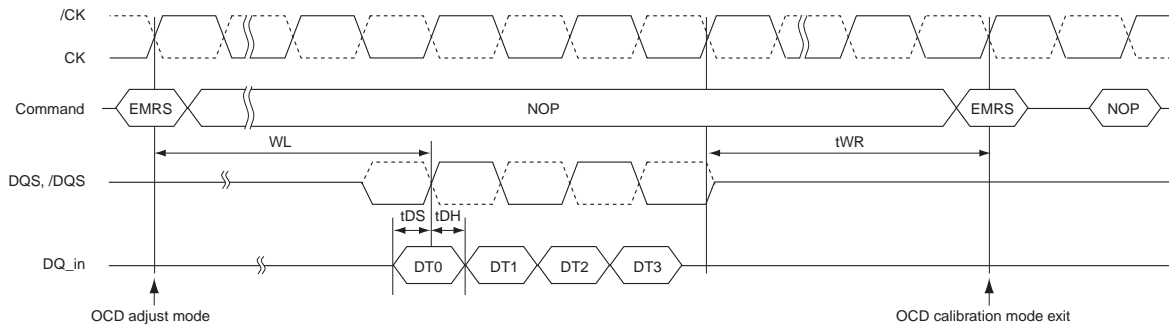

Output Impedance Control Register Set Cycle

Drive Mode

Drive mode, both drive (1) and drive (0), is used for controllers to measure DDR2 SDRAM Driver impedance before OCD impedance adjustment. In this mode, all outputs are driven out $tOIT$ after “Enter drive mode” command and all output drivers are turned-off $tOIT$ after “OCD calibration mode exit” command as the “Output Impedance Measurement/Verify Cycle”.

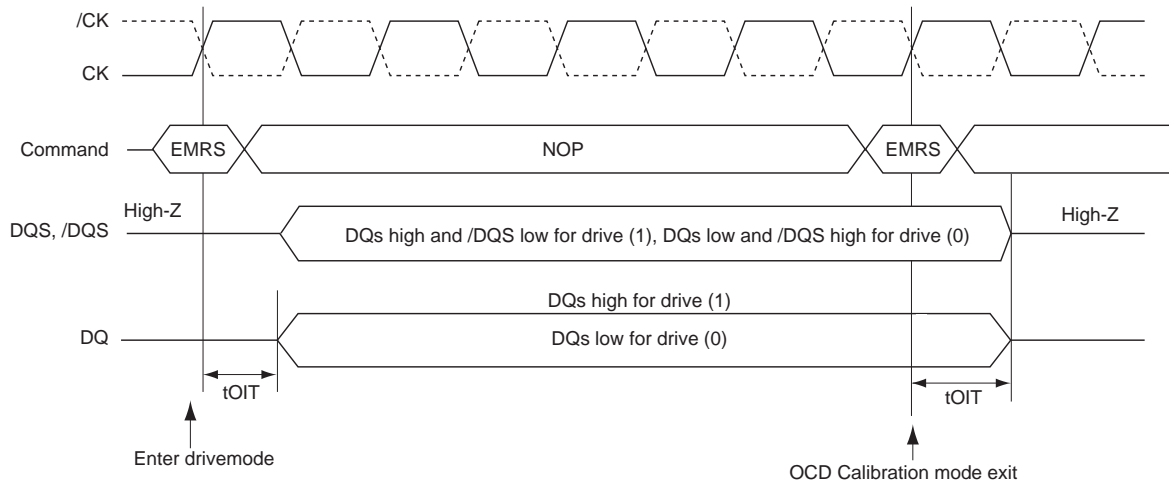

Output Impedance Measurement/Verify Cycle

ODT (On Die Termination)

On Die Termination (ODT), is a feature that allows a DRAM to turn on/off termination resistance for each DQ, DQS, /DQS, RDQS, /RDQS, and DM signal via the ODT control pin. The ODT feature is designed to improve signal integrity of the memory channel by allowing the DRAM controller to independently turn on/off termination resistance for any or all DRAM devices.

The ODT function is turned off and not supported in self-refresh mode.

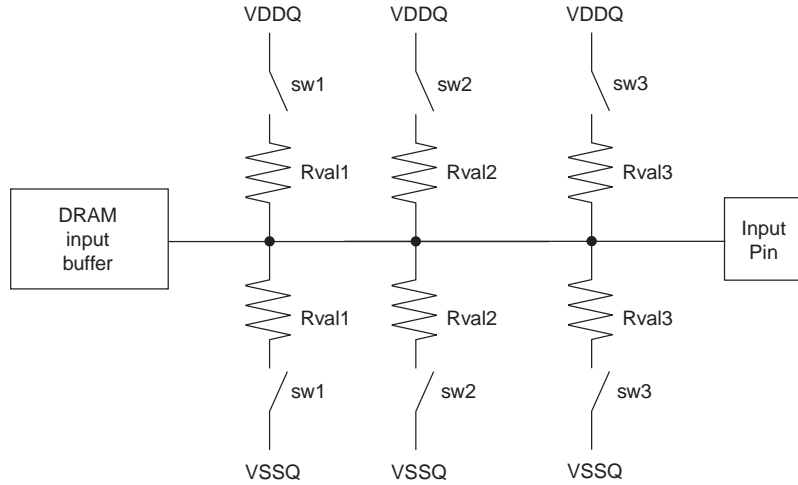

Switch sw1, sw2 or sw3 is enabled by ODT pin.
 Selection between sw1, sw2 or sw3 is determined by Rtt (nominal) in EMRS
 Termination included on all DQs, DM, DQS, /DQS, RDQS and /RDQS pins.
 Target Rtt (Ω) = (Rval1) / 2, (Rval2) / 2 or (Rval3) / 2

Functional Representation of ODT

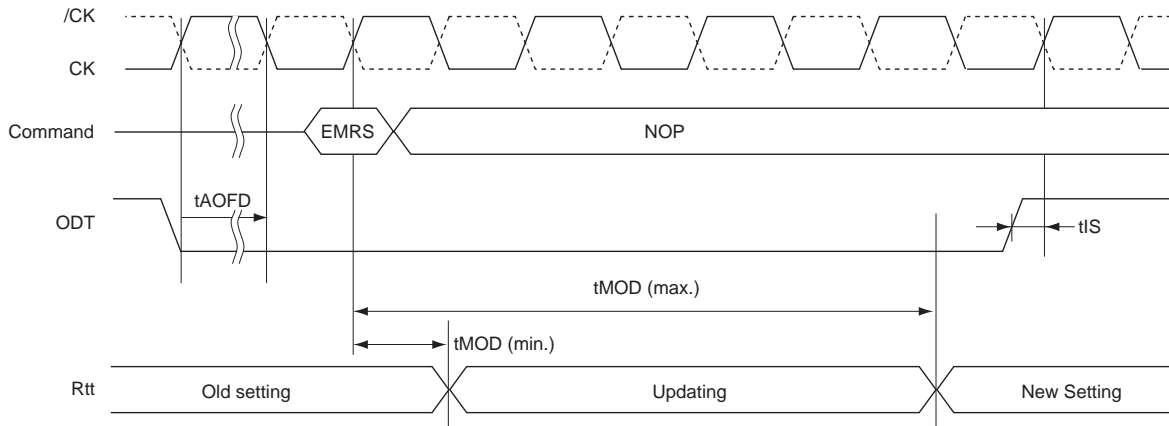

Note: tAOFD must be met before issuing EMRS command. ODT must remain low for the entire duration of tMOD window.

ODT update Delay Timing

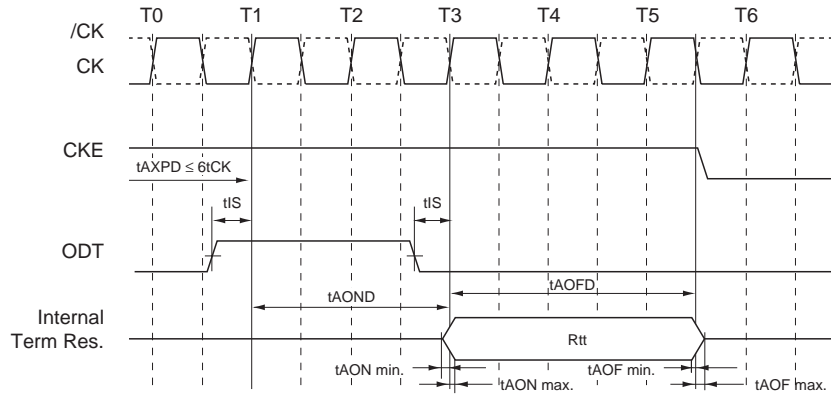

ODT Timing for Active and Standby Mode

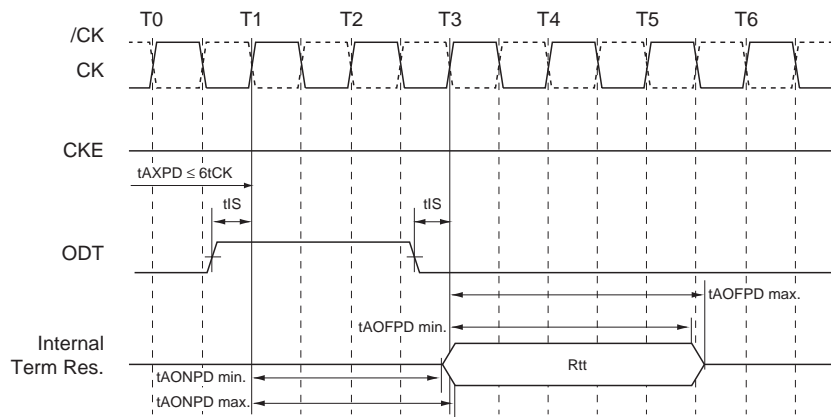

ODT Timing for Power-Down Mode

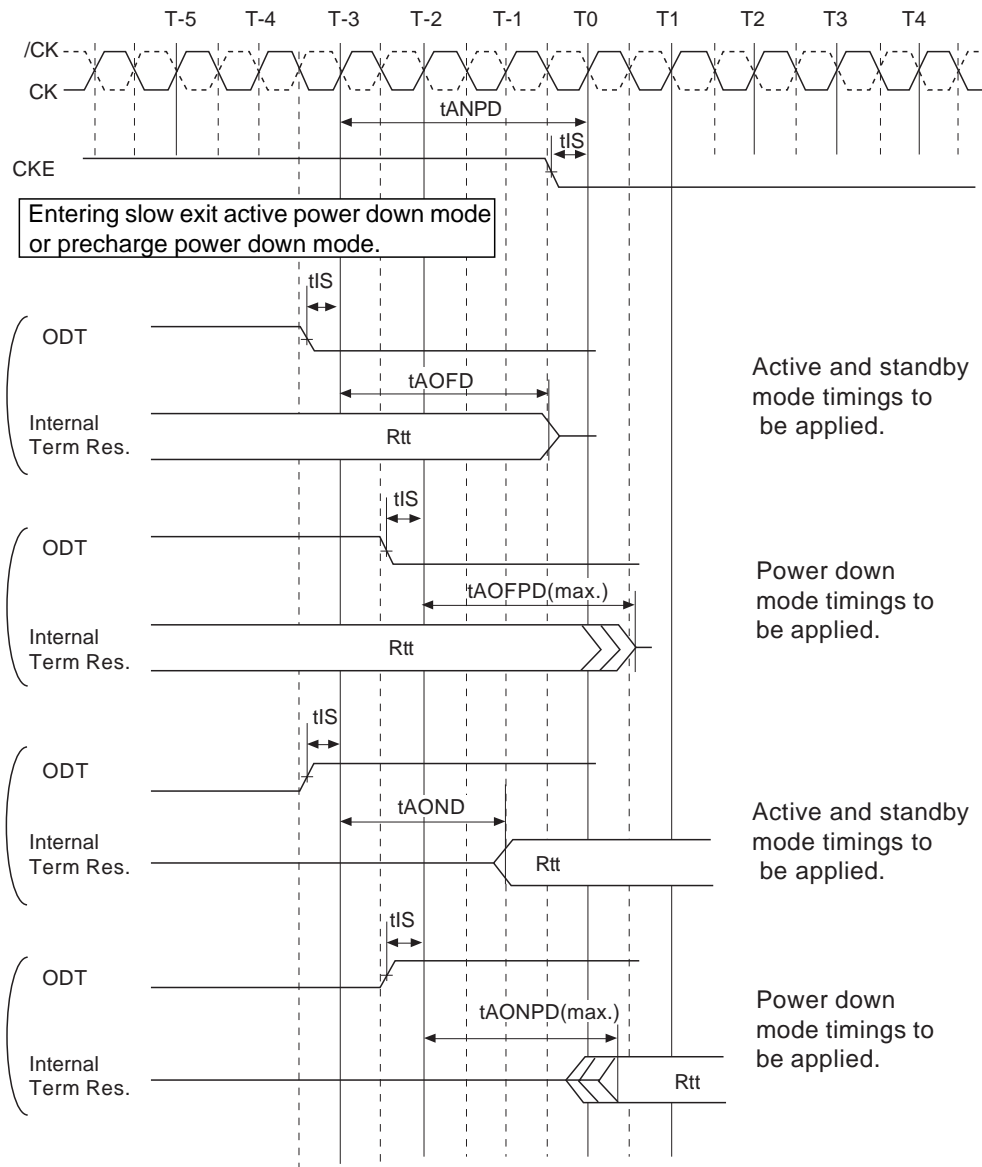

ODT Timing Mode Switch at Entering Power-Down Mode

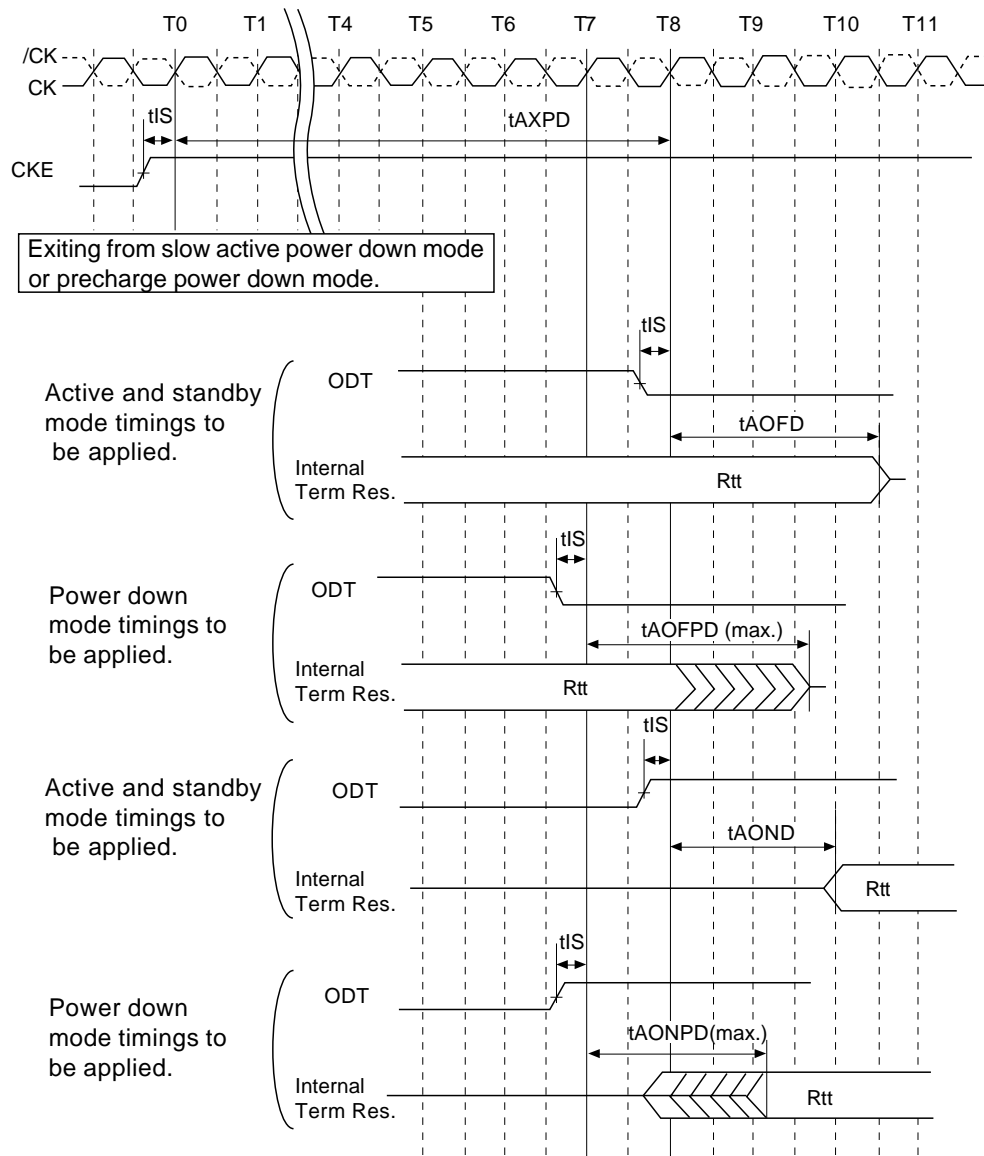

ODT Timing Mode Switch at Exiting Power-Down Mode

Bank Activate Command [ACT]

The bank activate command is issued by holding /CAS and /WE high with /CS and /RAS low at the rising edge of the clock. The bank addresses BA0 and BA1, are used to select the desired bank. The row address A0 through A13 is used to determine which row to activate in the selected bank. The Bank activate command must be applied before any read or write operation can be executed. Immediately after the bank activate command, the DDR2 SDRAM can accept a read or write command on the following clock cycle. If a R/W command is issued to a bank that has not satisfied the tRCD (min.) specification, then additive latency must be programmed into the device to delay when the R/W command is internally issued to the device. The additive latency value must be chosen to assure tRCD (min.) is satisfied. Additive latencies of 0, 1, 2, 3 and 4 are supported. Once a bank has been activated it must be precharged before another bank activate command can be applied to the same bank. The bank active and precharge times are defined as tRAS and tRP, respectively. The minimum time interval between successive bank activate commands to the same bank is determined by the /RAS cycle time of the device (tRC), which is equal to tRAS + tRP. The minimum time interval between successive bank activate commands to the different bank is determined by (tRRD).

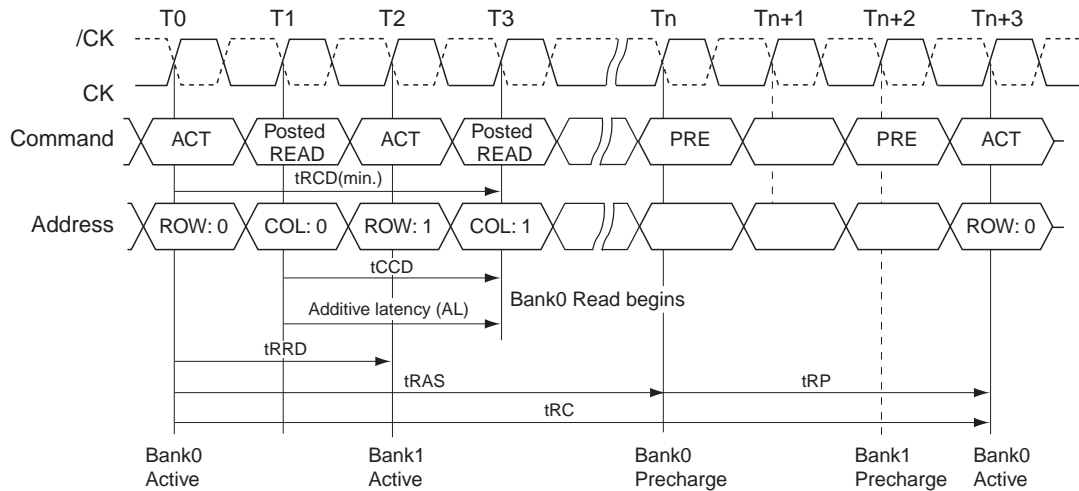

Bank Activate Command Cycle (tRCD = 3, AL = 2, tRP = 3, tRRD = 2, tCCD = 2)

Read and Write Access Modes

After a bank has been activated, a read or write cycle can be executed. This is accomplished by setting /RAS high, /CS and /CAS low at the clock's rising edge. /WE must also be defined at this time to determine whether the access cycle is a read operation (/WE high) or a write operation (/WE low).

The DDR2 SDRAM provides a fast column access operation. A single read or write command will initiate a serial read or write operation on successive clock cycles. The boundary of the burst cycle is strictly restricted to specific segments of the page length. For example, the 32M bits × 4 I/O × 4 banks chip has a page length of 2048 bits (defined by CA0 to CA9, CA11). The page length of 2048 is divided into 512 uniquely addressable boundary segments (4 bits each). A 4 bits burst operation will occur entirely within one of the 512 groups beginning with the column address supplied to the device during the read or write command (CA0 to CA9, CA11). The second, third and fourth access will also occur within this group segment, however, the burst order is a function of the starting address, and the burst sequence.

A new burst access must not interrupt the previous 4-bit burst operation. The minimum /CAS to /CAS delay is defined by tCCD, and is a minimum of 2 clocks for read or write cycles.

Posted /CAS

Posted /CAS operation is supported to make command and data bus efficient for sustainable bandwidths in DDR2 SDRAM. In this operation, the DDR2 SDRAM allows a /CAS read or write command to be issued immediately after the /RAS bank activate command (or any time during the /RAS-/CAS-delay time, tRCD, period). The command is held for the time of the Additive Latency (AL) before it is issued inside the device. The Read Latency (RL) is controlled by the sum of AL and the /CAS latency (CL). Therefore if a user chooses to issue a R/W command before the tRCD (min), then AL (greater than 0) must be written into the EMRS. The Write Latency (WL) is always defined as $RL - 1$ (read latency - 1) where read latency is defined as the sum of additive latency plus /CAS latency ($RL = AL + CL$).

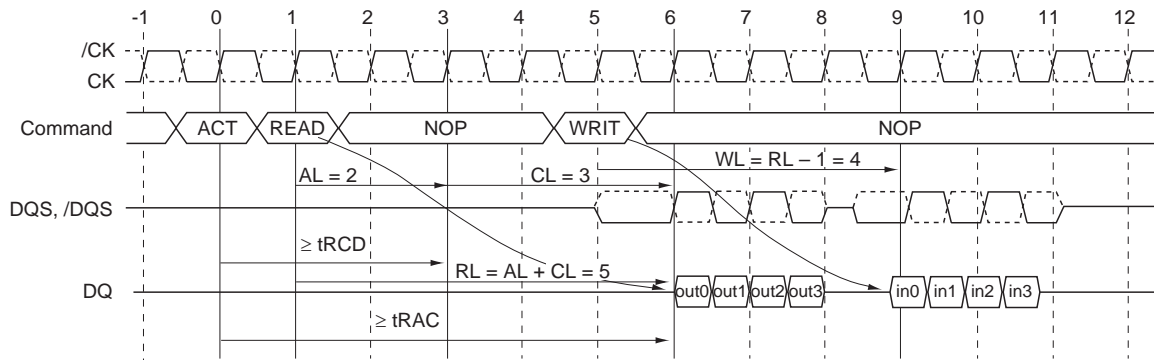

Read Followed by a Write to the Same Bank
[AL = 2 and CL = 3, RL = (AL + CL) = 5, WL = (RL - 1) = 4]

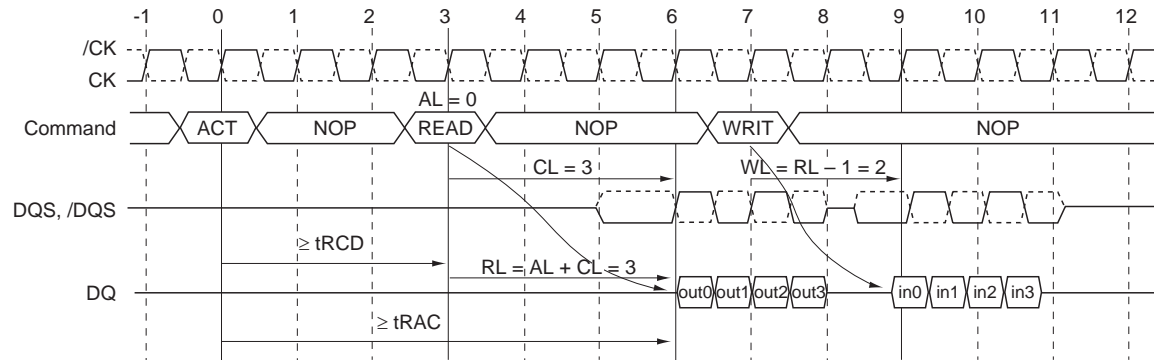

Read Followed by a Write to the Same Bank
[AL = 0 and CL = 3, RL = (AL + CL) = 3, WL = (RL - 1) = 2]

Burst Mode Operation

Burst mode operation is used to provide a constant flow of data to memory locations (write cycle), or from memory locations (read cycle). The parameters that define how the burst mode will operate are burst sequence and burst length. DDR2 SDRAM supports 4 bits burst and 8bits burst modes only. For 8 bits burst mode, full interleave address ordering is supported, however, sequential address ordering is nibble based for ease of implementation. The burst type, either sequential or interleaved, is programmable and defined by the address bit 3 (A3) of the MRS, which is similar to the DDR-I SDRAM operation. Seamless burst read or write operations are supported. Unlike DDR-I devices, interruption of a burst read or writes operation is limited to ready by Read or Write by Write at the boundary of Burst 4. Therefore the burst stop command is not supported on DDR2 SDRAM devices.

[Burst Length and Sequence, BL = 4]

Burst length	Starting address (A1, A0)	Sequential addressing (decimal)	Interleave addressing (decimal)
4	00	0, 1, 2, 3	0, 1, 2, 3
	01	1, 2, 3, 0	1, 0, 3, 2
	10	2, 3, 0, 1	2, 3, 0, 1
	11	3, 0, 1, 2	3, 2, 1, 0

[Burst Length and Sequence, BL = 8]

Burst length	Starting address (A2, A1, A0)	Sequential addressing (decimal)	Interleave addressing (decimal)
8	000	0, 1, 2, 3, 4, 5, 6, 7	0, 1, 2, 3, 4, 5, 6, 7
	001	1, 2, 3, 0, 5, 6, 7, 4	1, 0, 3, 2, 5, 4, 7, 6
	010	2, 3, 0, 1, 6, 7, 4, 5	2, 3, 0, 1, 6, 7, 4, 5
	011	3, 0, 1, 2, 7, 4, 5, 6	3, 2, 1, 0, 7, 6, 5, 4
	100	4, 5, 6, 7, 0, 1, 2, 3	4, 5, 6, 7, 0, 1, 2, 3
	101	5, 6, 7, 4, 1, 2, 3, 0	5, 4, 7, 6, 1, 0, 3, 2
	110	6, 7, 4, 5, 2, 3, 0, 1	6, 7, 4, 5, 2, 3, 0, 1
	111	7, 4, 5, 6, 3, 0, 1, 2	7, 6, 5, 4, 3, 2, 1, 0

Note: Page length is a function of I/O organization and column addressing
 32M bits × 4 organization (CA0 to CA9, CA11); Page Length = 2048 bits
 16M bits × 8 organization (CA0 to CA9); Page Length = 1024 bits
 8M bits × 16 organization (CA0 to CA9); Page Length = 1024 bits

Burst Read Command [READ]

The Burst Read command is initiated by having /CS and /CAS low while holding /RAS and /WE high at the rising edge of the clock. The address inputs determine the starting column address for the burst. The delay from the start of the command to when the data from the first cell appears on the outputs is equal to the value of the read latency (RL). The data strobe output (DQS) is driven low 1 clock cycle before valid data (DQ) is driven onto the data bus. The first bit of the burst is synchronized with the rising edge of the data strobe (DQS). Each subsequent data-out appears on the DQ pin in phase with the DQS signal in a source synchronous manner.

The RL is equal to an additive latency (AL) plus /CAS latency (CL). The CL is defined by the mode register set (MRS), similar to the existing SDR and DDR-I SDRAMs. The AL is defined by the extended mode register set (EMRS).

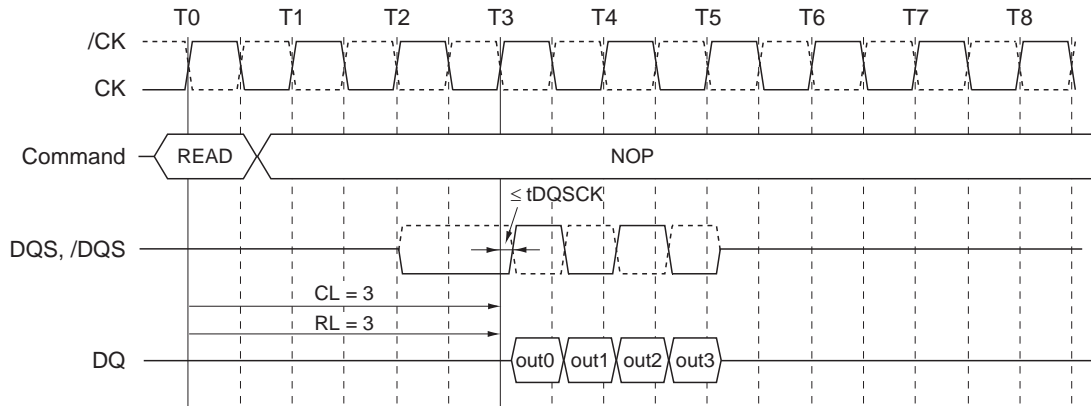

Burst Read Operation (RL = 3, BL = 4 (AL = 0 and CL = 3))

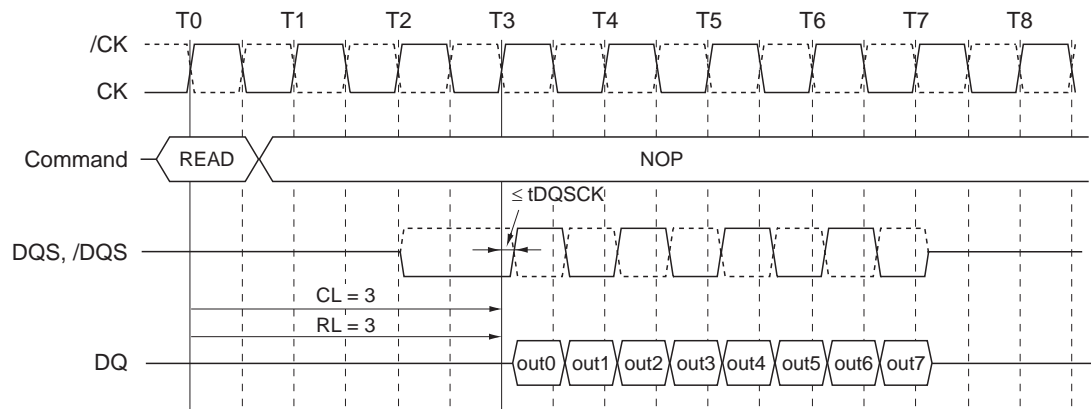

Burst Read Operation (RL = 3, BL = 8 (AL = 0 and CL = 3))

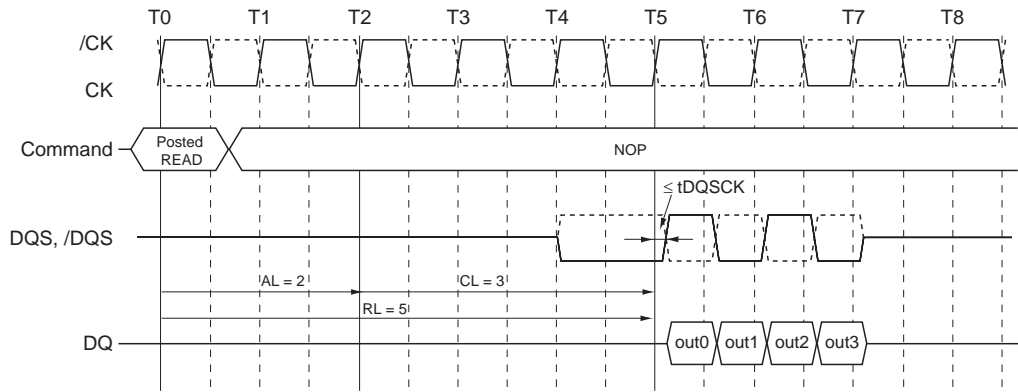

Burst Read Operation (RL = 5, BL = 4 (AL = 2, CL = 3))

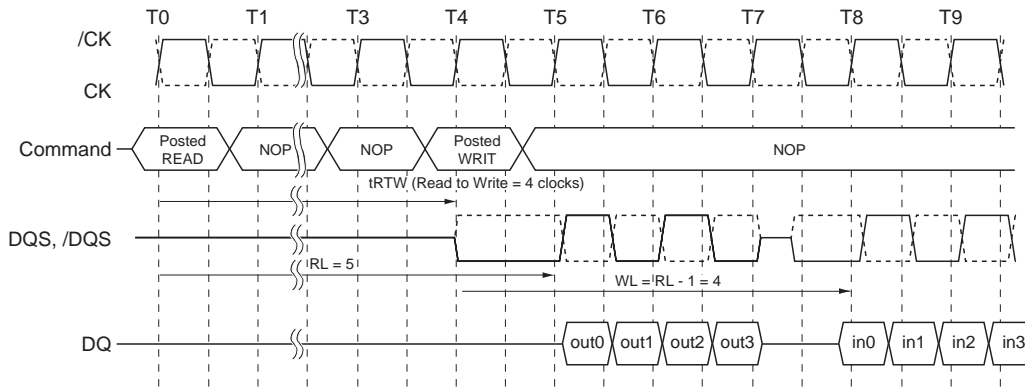

Burst Read Followed by Burst Write (RL = 5, WL = RL-1 = 4, BL = 4)

The minimum time from the burst read command to the burst write command is defined by a read-to-write-turn-around-time, which is 4 clocks in the case of BL = 4 operation, 6 clocks in case of BL =8 operation.

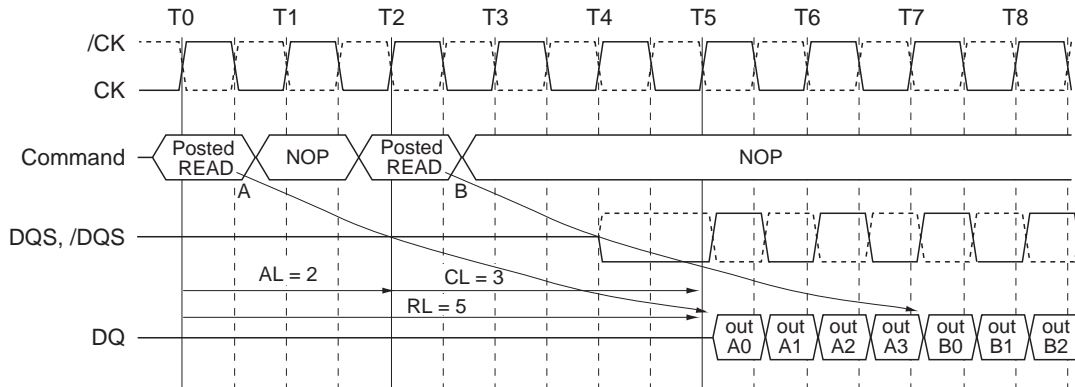

Seamless Burst Read Operation (RL = 5, AL = 2, and CL = 3)

Enabling a read command at every other clock supports the seamless burst read operation. This operation is allowed regardless of same or different banks as long as the banks are activated.

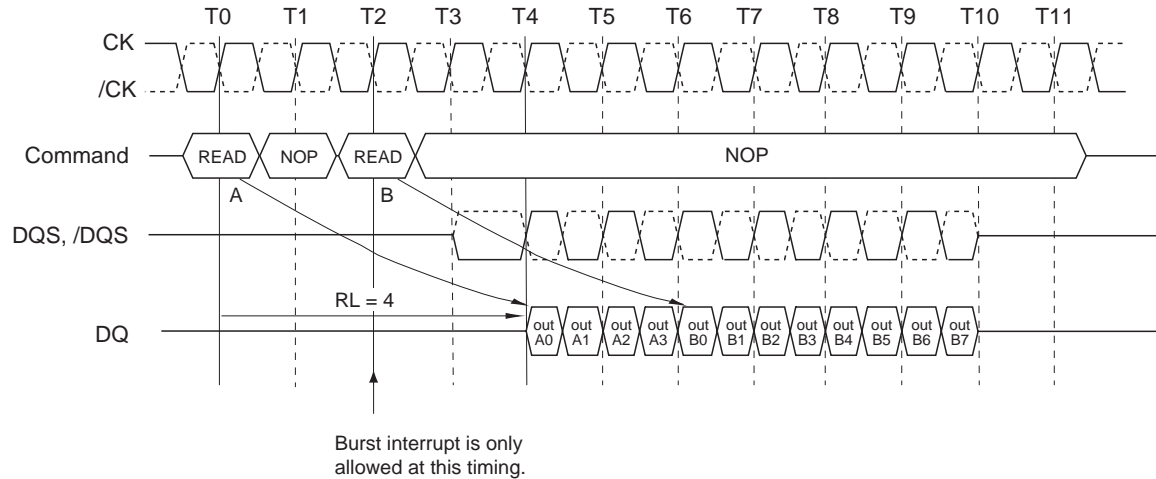

Burst Read Interrupt by Read

- Notes:
1. Read burst interrupt function is only allowed on burst of 8. burst interrupt of 4 is prohibited.
 2. Read burst of 8 can only be interrupted by another read command. Read burst interruption by write command or precharge command is prohibited.
 3. Read burst interrupt must occur exactly two clocks after previous read command. any other read burst interrupt timings are prohibited.
 4. Read burst interruption is allowed to any bank inside DRAM.
 5. Read burst with auto precharge enabled is not allowed to interrupt.
 6. Read burst interruption is allowed by another read with auto precharge command.
 7. All command timings are referenced to burst length set in the mode register. They are not referenced to actual burst. For example, minimum read to precharge timing is $AL + BL/2$ where BL is the burst length set in the mode register and not the actual burst (which is shorter because of interrupt).

Burst Write Command [WRIT]

The Burst Write command is initiated by having /CS, /CAS and /WE low while holding /RAS high at the rising edge of the clock. The address inputs determine the starting column address. Write latency (WL) is defined by a read latency (RL) minus one and is equal to $(AL + CL - 1)$. A data strobe signal (DQS) should be driven low (preamble) one clock prior to the WL. The first data bit of the burst cycle must be applied to the DQ pins at the first rising edge of the DQS following the preamble. The t_{DQSS} specification must be satisfied for write cycles. The subsequent burst bit data are issued on successive edges of the DQS until the burst length of 4 is completed. When the burst has finished, any additional data supplied to the DQ pins will be ignored. The DQ Signal is ignored after the burst write operation is complete. The time from the completion of the burst write to bank precharge is the write recovery time (t_{WR}).

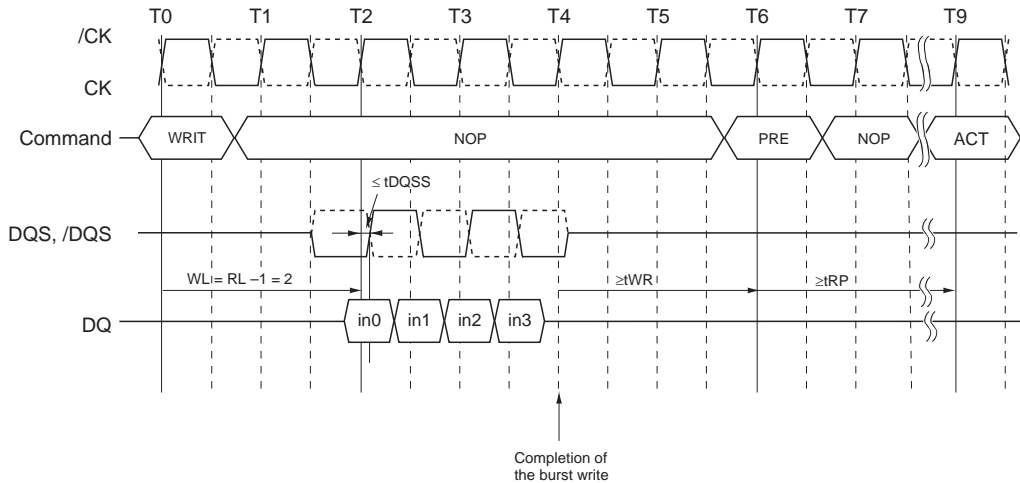

Burst Write Operation (RL = 3, WL = 2, BL = 4 $t_{WR} = 2$ (AL=0, CL=3))

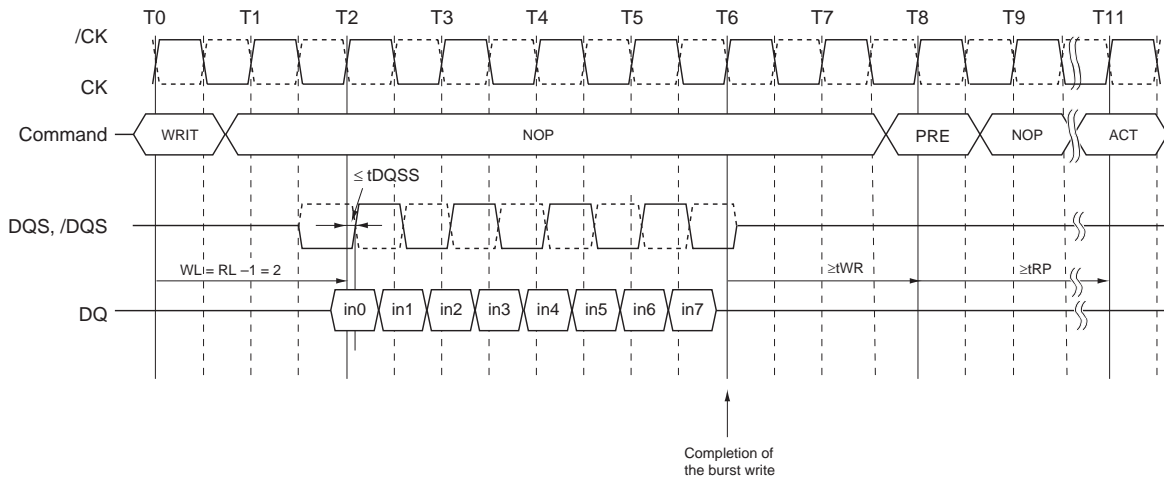

Burst Write Operation (RL = 3, WL = 2, BL = 8 (AL=0, CL=3))

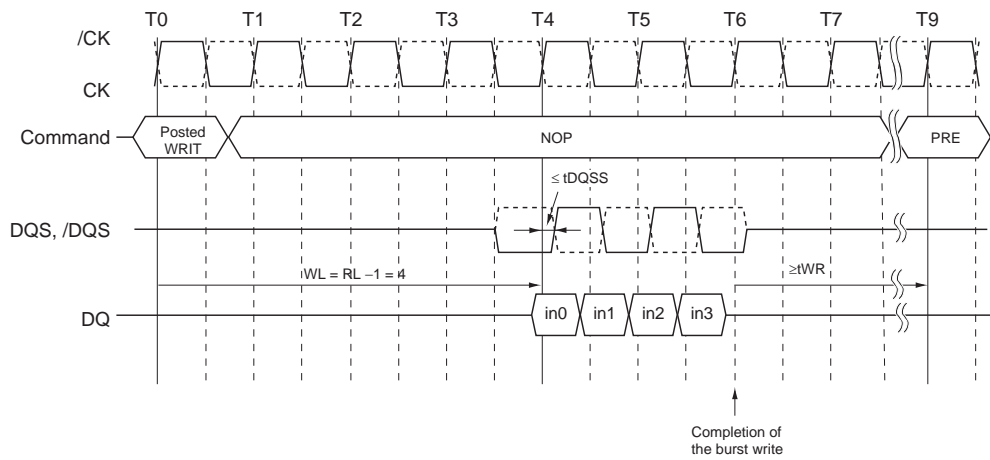

Burst Write Operation (RL = 5, WL = 4, BL = 4 tWR = 3 (AL=2, CL=3))

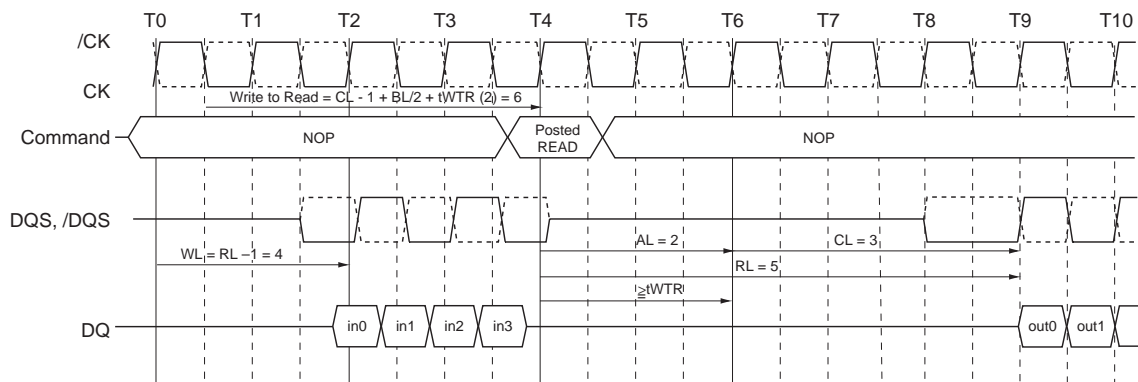

Burst Write Followed by Burst Read (RL = 5, BL = 4, WL = 4, tWTR = 2 (AL=2, CL=3))

The minimum number of clock from the burst write command to the burst read command is $CL - 1 + BL/2 +$ a write to-read-turn-around-time ($tWTR$). This $tWTR$ is not a write recovery time (tWR) but the time required to transfer the 4bit write data from the input buffer into sense amplifiers in the array.

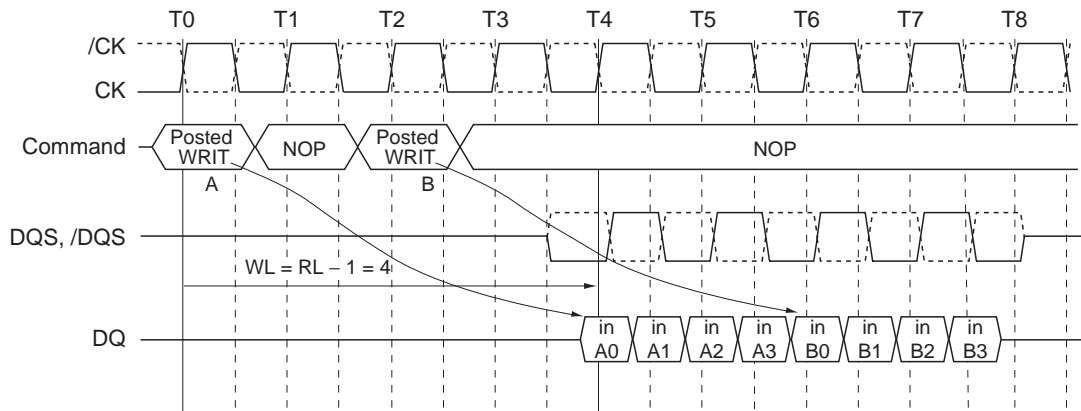

Seamless Burst Write Operation (RL = 5, WL = 4, BL = 4)

Enabling a write command every other clock supports the seamless burst write operation. This operation is allowed regardless of same or different banks as long as the banks are activated.

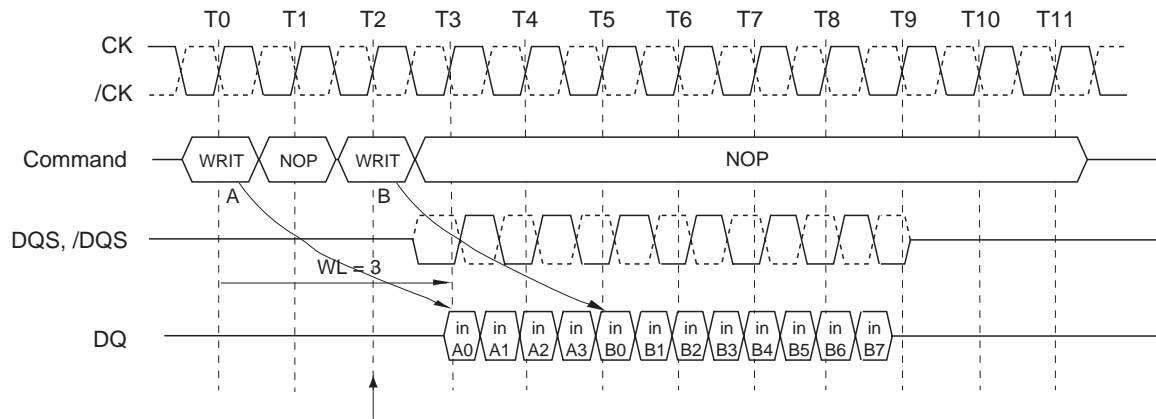

Burst interrupt is only allowed at this timing.

Write Interrupt by Write (WL = 3, BL = 8)

- Notes :
1. Write burst interrupt function is only allowed on burst of 8. Burst interrupt of 4 is prohibited.
 2. Write burst of 8 can only be interrupted by another write command. Write burst interruption by read command or precharge command is prohibited.
 3. Write burst interrupt must occur exactly two clocks after previous write command. Any other write burst interrupt timings are prohibited.
 4. Write burst interruption is allowed to any bank inside DRAM.
 5. Write burst with auto precharge enabled is not allowed to interrupt.
 6. Write burst interruption is allowed by another write with auto precharge command.
 7. All command timings are referenced to burst length set in the mode register. They are not referenced to actual burst. For example, minimum write to precharge timing is $WL+BL/2+tWR$ where tWR starts with the rising clock after the un-interrupted burst end and not from the end of actual burst end.

Write Data Mask

One write data mask (DM) pin for each 8 data bits (DQ) will be supported on DDR2 SDRAMs, Consistent with the implementation on DDR-I SDRAMs. It has identical timings on write operations as the data bits, and though used in a uni-directional manner, is internally loaded identically to data bits to insure matched system timing. DM is not used during read cycles.

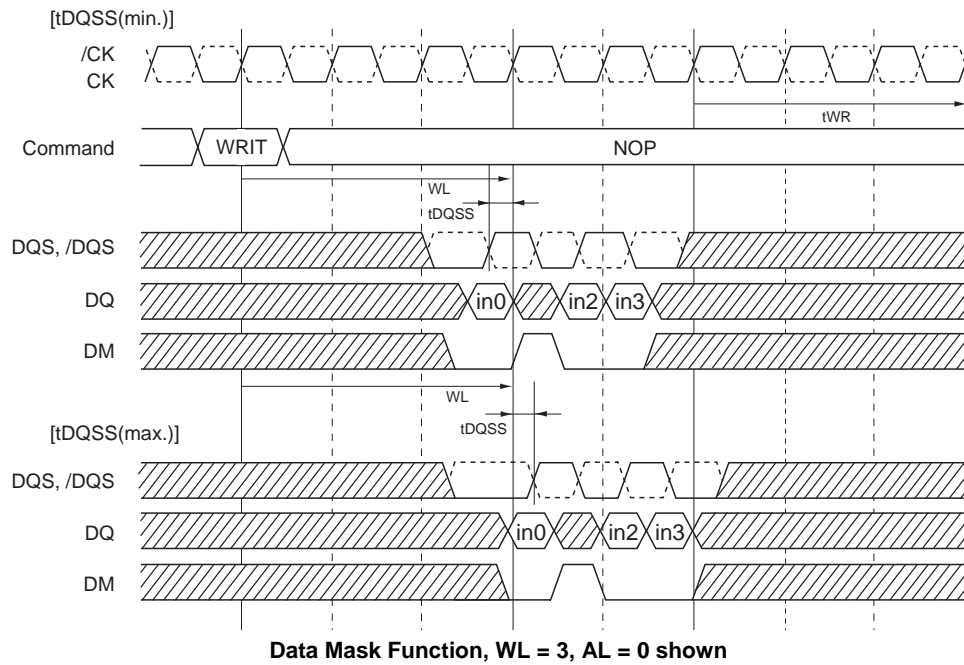
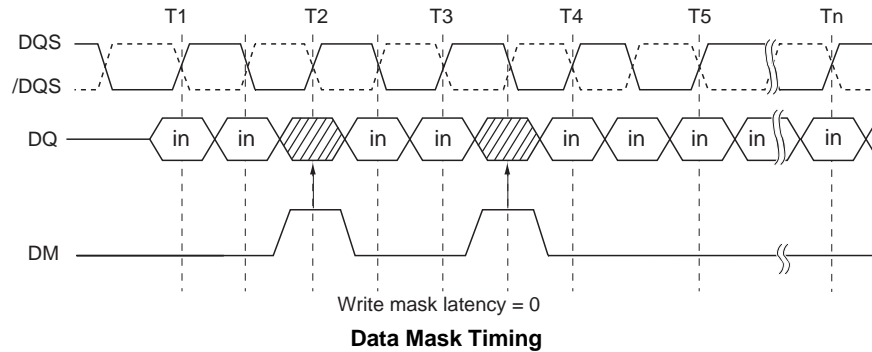

Precharge Command [PRE]

The precharge command is used to precharge or close a bank that has been activated. The precharge command is triggered when /CS, /RAS and /WE are low and /CAS is high at the rising edge of the clock. The precharge command can be used to precharge each bank independently or all banks simultaneously. Three address bits A10, BA0 and BA1 are used to define which bank to precharge when the command is issued.

[Bank Selection for Precharge by Address Bits]

A10	BA0	BA1	Precharged Bank(s)
L	L	L	Bank 0 only
L	H	L	Bank 1 only
L	L	H	Bank 2 only
L	H	H	Bank 3 only
H	x	x	All banks 0 to 3

Remark: H: VIH, L: VIL, x: VIH or VIL

Burst Read Operation Followed by Precharge

Minimum read to precharge command spacing to the same bank = AL + BL/2 clocks

For the earliest possible precharge, the precharge command may be issued on the rising edge that is "Additive latency (AL) + BL/2 clocks" after a Read command. A new bank active (command) may be issued to the same bank after the RAS precharge time (tRP). A precharge command cannot be issued until tRAS is satisfied.

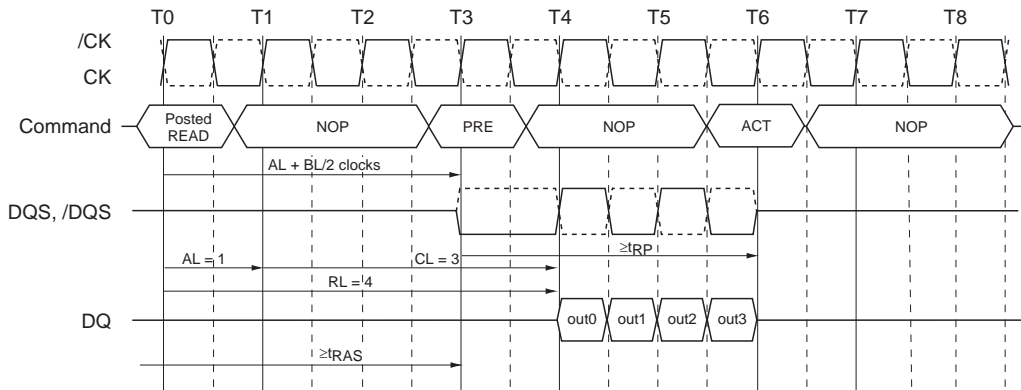

Burst Read Operation Followed by Precharge (RL = 4, BL = 4 (AL=1, CL=3))

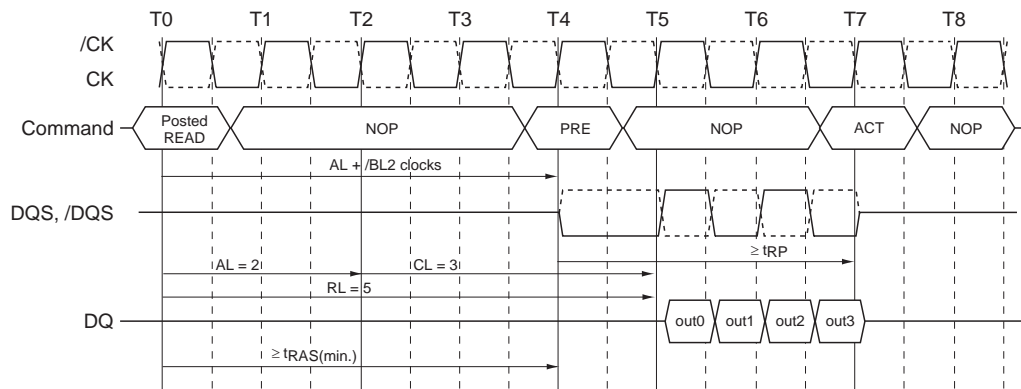

Burst Read Operation Followed by Precharge (RL = 5, BL = 4 (AL=2, CL=3))

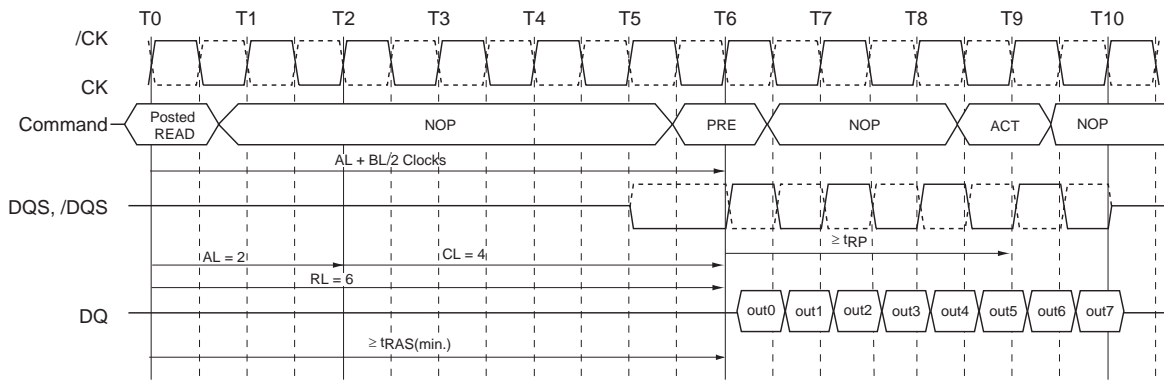

Burst Read Operation Followed by Precharge (RL = 6 (AL=2, CL=4, BL=8))

Burst Write followed by Precharge

Minimum Write to Precharge Command spacing to the same bank = $WL + BL/2$ clocks + tWR

For write cycles, a delay must be satisfied from the completion of the last burst write cycle until the precharge command can be issued. This delay is known as a write recovery time (tWR) referenced from the completion of the burst write to the precharge command. No precharge command should be issued prior to the tWR delay, as DDR2 SDRAM allows the burst interrupt operation only Read by Read or Write by Write at the boundary of burst 4.

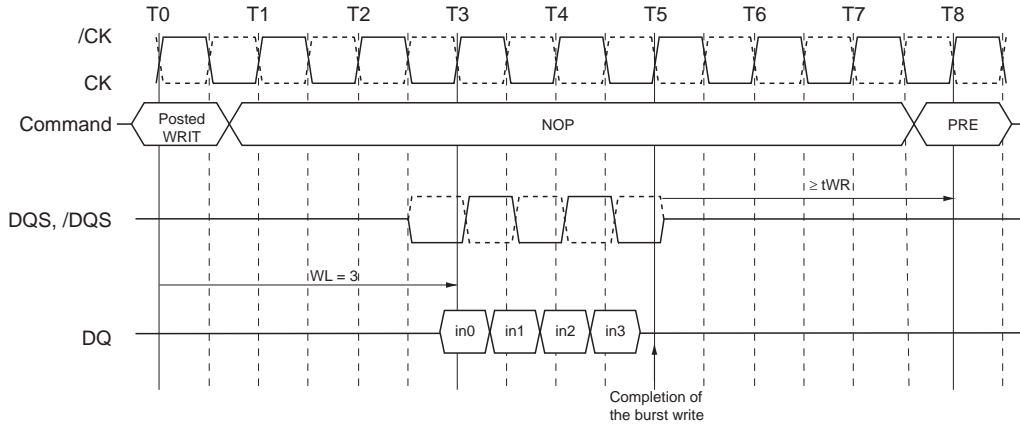

Burst Write Followed by Precharge ($WL = (RL-1) = 3$)

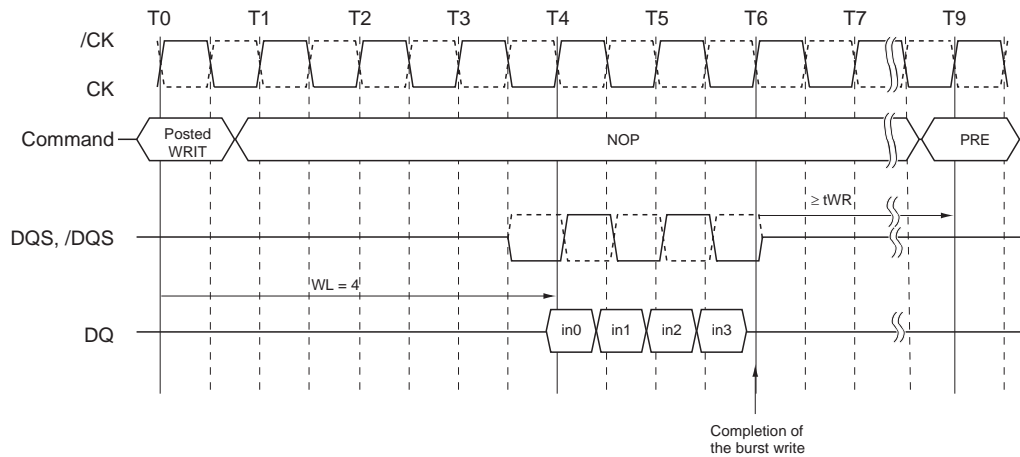

Burst Write Followed by Precharge ($WL = (RL-1) = 4$)

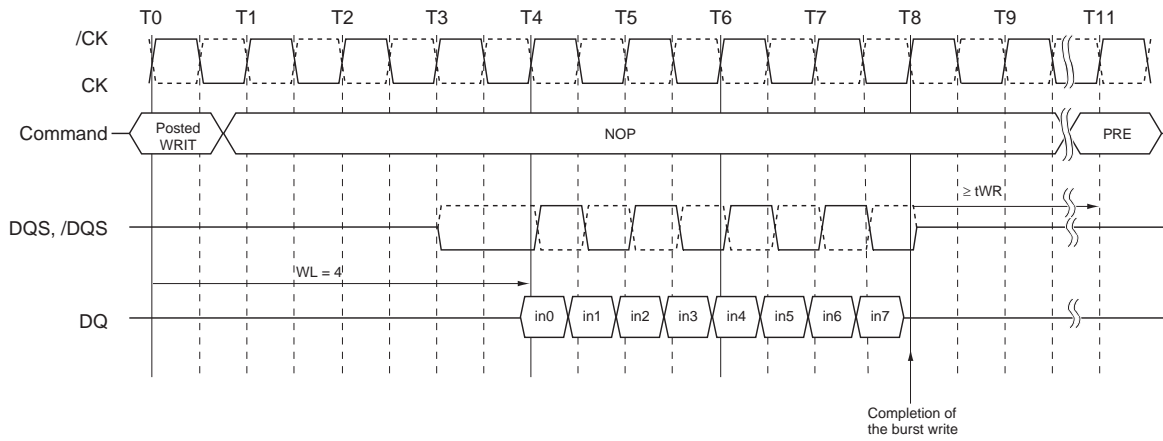

Burst Write Followed by Precharge (WL = (RL-1) = 4, BL= 8)

Auto Precharge Operation

Before a new row in an active bank can be opened, the active bank must be precharged using either the precharge command or the auto precharge function. When a read or a write command is given to the DDR2 SDRAM, the /CAS timing accepts one extra address, column address A10, to allow the active bank to automatically begin precharge at the earliest possible moment during the burst read or write cycle. If A10 is low when the read or write Command is issued, then normal read or write burst operation is executed and the bank remains active at the completion of the burst sequence. If A10 is high when the Read or Write Command is issued, then the auto precharge function is engaged. During auto precharge, a read Command will execute as normal with the exception that the active bank will begin to precharge on the rising edge which is /CAS latency (CL) clock cycles before the end of the read burst.

Auto precharge can also be implemented during Write commands. The precharge operation engaged by the Auto precharge command will not begin until the last data of the burst write sequence is properly stored in the memory array.

This feature allows the precharge operation to be partially or completely hidden during burst read cycles (dependent upon /CAS latency) thus improving system performance for random data access. The /RAS lockout circuit internally delays the Precharge operation until the array restore operation has been completed so that the auto precharge command may be issued with any read or write command.

Burst Read with Auto Precharge [READA]

If A10 is high when a Read Command is issued, the Read with Auto Precharge function is engaged. The DDR2 SDRAM starts an auto Precharge operation on the rising edge which is (AL + BL/2) cycles later from the read with AP command when tRAS (min.) is satisfied. If tRAS (min.) is not satisfied at the edge, the start point of auto precharge operation will be delayed until tRAS (min.) is satisfied. A new bank active (command) may be issued to the same bank if the following two conditions are satisfied simultaneously.

- (1) The /RAS precharge time (tRP) has been satisfied from the clock at which the auto precharge begins.
- (2) The /RAS cycle time (tRC) from the previous bank activation has been satisfied.

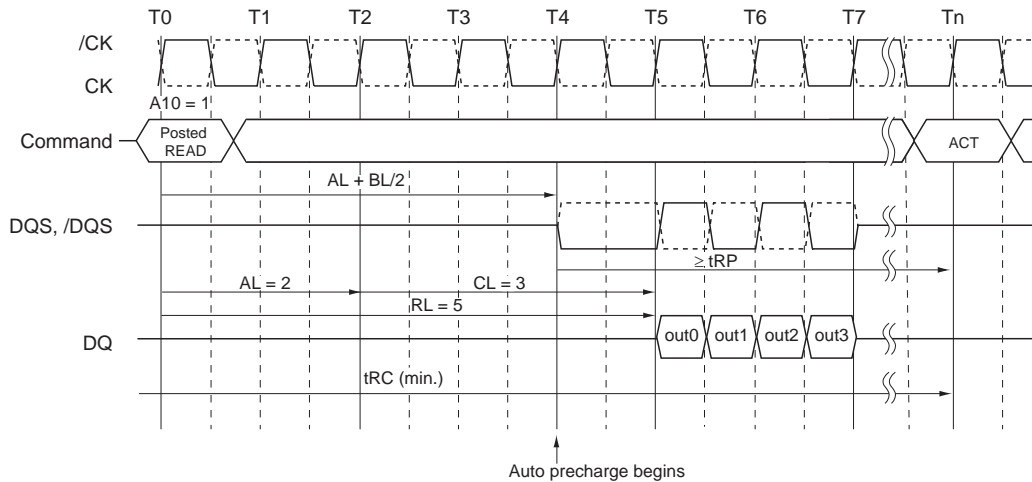

Burst Read with Auto Precharge Followed by an Activation to the Same Bank (tRC limit)
 (RL = 5, BL = 4 (AL = 2, CL = 3, tRTP ≤ 2tCK))

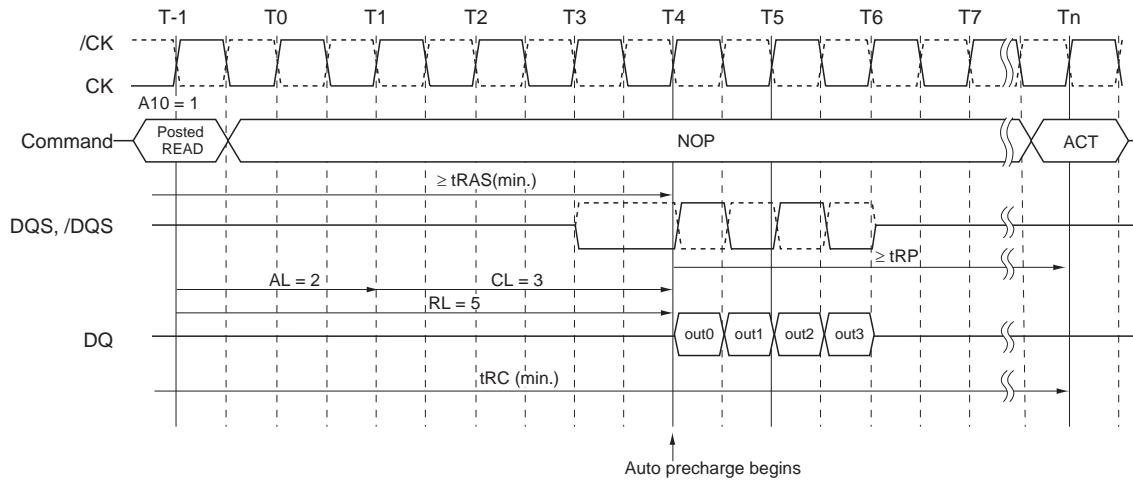

**Burst Read with Auto Precharge Followed by an Activation to the Same Bank (t_{RAS} lockout case)
(RL = 5, BL = 4 (AL = 2, CL = 3))**

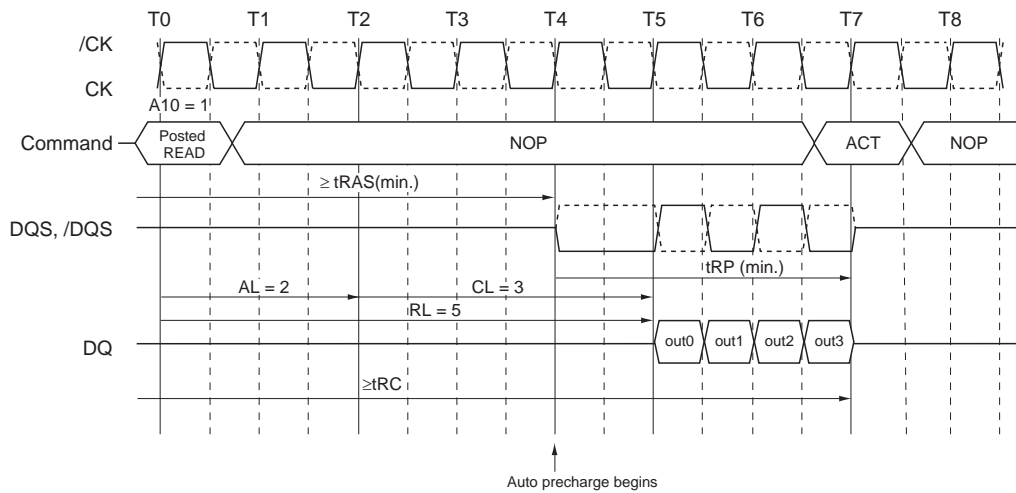

**Burst Read with Auto Precharge Followed by an Activation to the Same Bank (t_{RP} limit)
(RL = 5, BL = 4 (AL = 2, CL = 3, $t_{RTP} \leq 2t_{CK}$))**

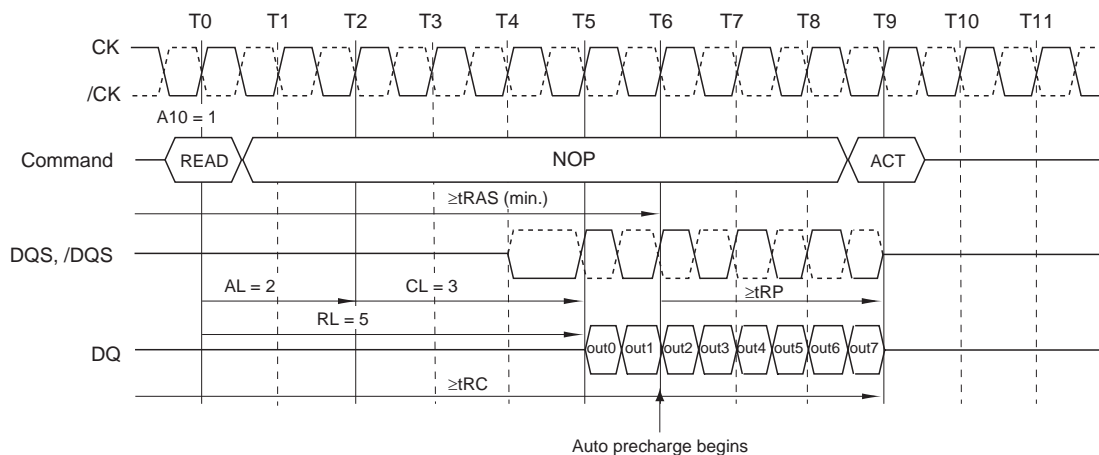

**Burst Read with Auto Precharge Followed by an Activation to the Same Bank
(RL = 5, BL = 8 (AL = 2, CL = 3, $t_{RTP} \leq 2t_{CK}$))**

Burst Write with Auto Precharge [WRITA]

If A10 is high when a write command is issued, the Write with auto precharge function is engaged. The DDR2 SDRAM automatically begins precharge operation after the completion of the burst writes plus write recovery time (t_{WR}). The bank undergoing auto precharge from the completion of the write burst may be reactivated if the following two conditions are satisfied.

- (1) The data-in to bank activate delay time ($t_{WR} + t_{RP}$) has been satisfied.
- (2) The /RAS cycle time (t_{RC}) from the previous bank activation has been satisfied.

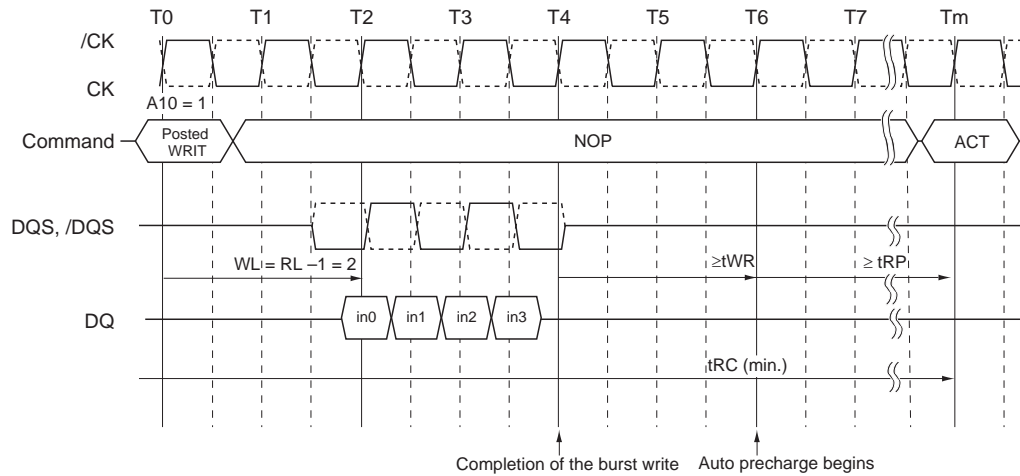

Burst Write with Auto Precharge (t_{RC} Limit) ($WL = 2, t_{WR} = 2$)

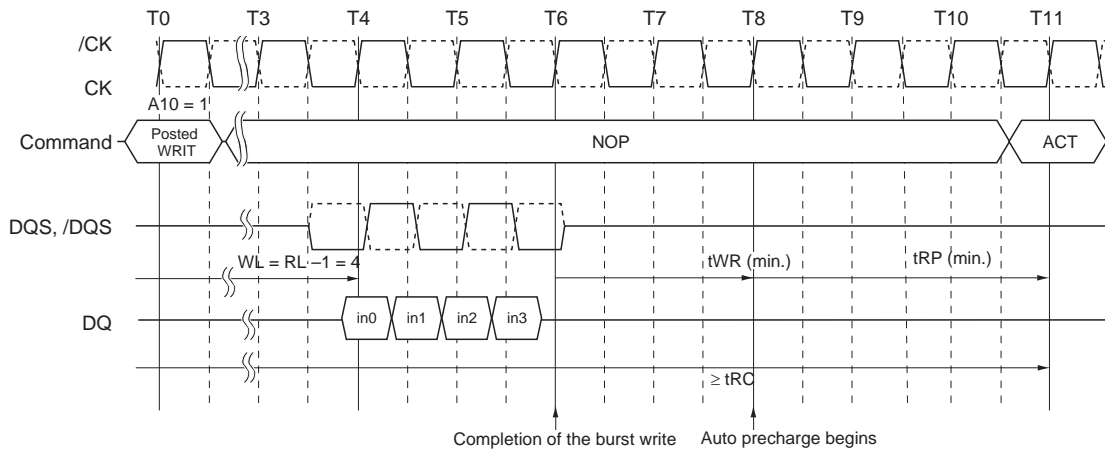

Burst Write with Auto Precharge ($t_{WR} + t_{RP}$) ($WL = 4, t_{WR} = 2, t_{RP} = 3$)

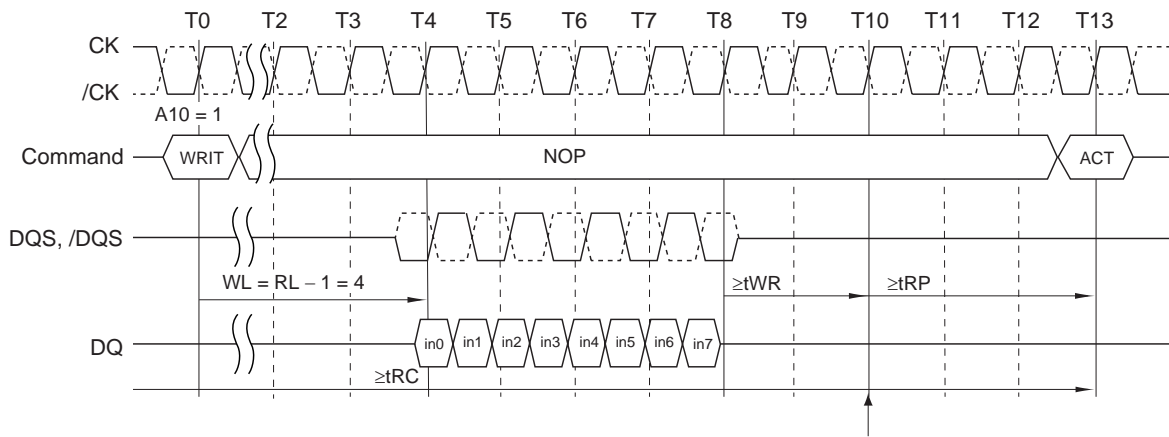

Auto precharge begins
Burst Write with Auto Precharge Followed by an Activation to the Same Bank
(WL = 4, BL = 8, tWR = 2, tRP = 3)

Refresh Requirements

DDR2 SDRAM requires a refresh of all rows in any rolling 64ms interval. Each refresh is generated in one of two ways: by an explicit automatic refresh command, or by an internally timed event in self-refresh mode. Dividing the number of device rows into the rolling 64 ms interval defines the average refresh interval, t_{REFI} , which is a guideline to controllers for distributed refresh timing.

Automatic Refresh Command [REF]

When $/CS$, $/RAS$ and $/CAS$ are held low and $/WE$ high at the rising edge of the clock, the chip enters the automatic refresh mode (REF). All banks of the DDR2 SDRAM must be precharged and idle for a minimum of the precharge time (t_{RP}) before the auto-refresh command (REF) can be applied. An address counter, internal to the device, supplies the bank address during the refresh cycle. No control of the external address bus is required once this cycle has started.

When the refresh cycle has completed, all banks of the DDR2 SDRAM will be in the precharged (idle) state. A delay between the auto-refresh command (REF) and the next activate command or subsequent auto-refresh command must be greater than or equal to the auto-refresh cycle time (t_{RFC}).

To allow for improved efficiency in scheduling and switching between tasks, some flexibility in the absolute refresh interval is provided. A maximum of 8 refresh commands can be posted to any given DDR2 SDRAM, meaning that the maximum absolute interval between any refresh command and the next Refresh command is $9 \times t_{REFI}$.

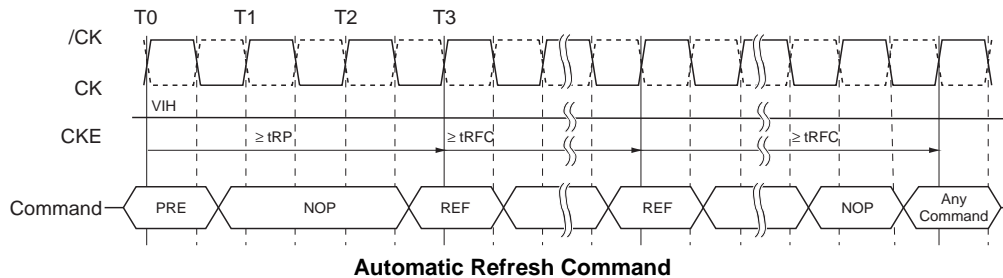

Self Refresh Command [SELF]

The DDR2 SDRAM device has a built-in timer to accommodate self-refresh operation. The self-refresh command is defined by having /CS, /RAS, /CAS and CKE held low with /WE high at the rising edge of the clock.

ODT must be turned off before issuing self-refresh command, by either driving ODT pin low or using EMRS command. Once the command is registered, CKE must be held low to keep the device in self-refresh mode.

When the DDR2 SDRAM has entered self-refresh mode all of the external signals except CKE, are “don’t care”. The clock is internally disabled during self-refresh operation to save power. The user may change the external clock frequency or halt the external clock one clock after Self-Refresh entry is registered, however, the clock must be restarted and stable before the device can exit self-refresh operation. Once self-refresh exit command is registered, a delay equal or longer than the tXSNR or tXSRD must be satisfied before a valid command can be issued to the device. CKE must remain high for the entire self-refresh exit period tXSRD for proper operation. NOP or deselect commands must be registered on each positive clock edge during the self-refresh exit interval. ODT should also be turned off during tXSRD.

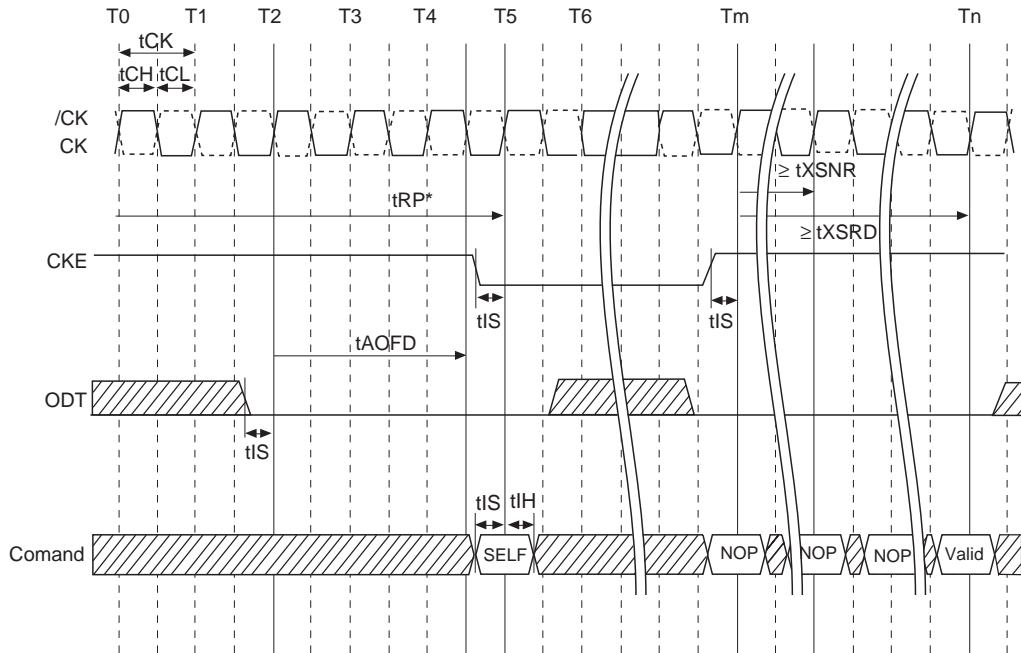

- Notes: 1. Device must be in the "All banks idle" state prior to entering self refresh mode.
- 2. ODT must be turned off tAOFD before entering self refresh mode, and can be turned on again when tXSRD timing is satisfied.
- 3. tXSRD is applied for a read or a read with autoprecharge command.
- 4. tXSNR is applied for any command except a read or a read with autoprecharge command.

Self Refresh Command

Power-Down [PDEN]

Power-down is synchronously entered when CKE is registered low (along with NOP or deselect command). CKE is not allowed to go low while mode register or extended mode register command time, or read or write operation is in progress. CKE is allowed to go low while any of other operations such as row activation, precharge or auto precharge, or auto-refresh is in progress, but power-down IDD spec will not be applied until finishing those operations. Timing diagrams are shown in the following pages with details for entry into power-down.

The DLL should be in a locked state when power-down is entered. Otherwise DLL should be reset after exiting power-down mode for proper read operation.

If power-down occurs when all banks are idle, this mode is referred to as precharge power-down; if power-down occurs when there is a row active in any bank, this mode is referred to as active power-down. Entering power-down deactivates the input and output buffers, excluding CK, /CK, ODT and CKE. Also the DLL is disabled upon entering precharge power-down or slow exit active power-down, but the DLL is kept enabled during fast exit active power-down. In power-down mode, CKE low and a stable clock signal must be maintained at the inputs of the DDR2 SDRAM, and ODT should be in a valid state but all other input signals are "Don't Care". CKE low must be maintained until tCKE has been satisfied. Power-down duration is limited by 9 times tREFI of the device.

The power-down state is synchronously exited when CKE is registered high (along with a NOP or deselect command). CKE high must be maintained until tCKE has been satisfied. A valid, executable command can be applied with power-down exit latency, tXP, tXARD, or tXARDS, after CKE goes high. Power-down exit latency is defined at AC Characteristics table of this data sheet.

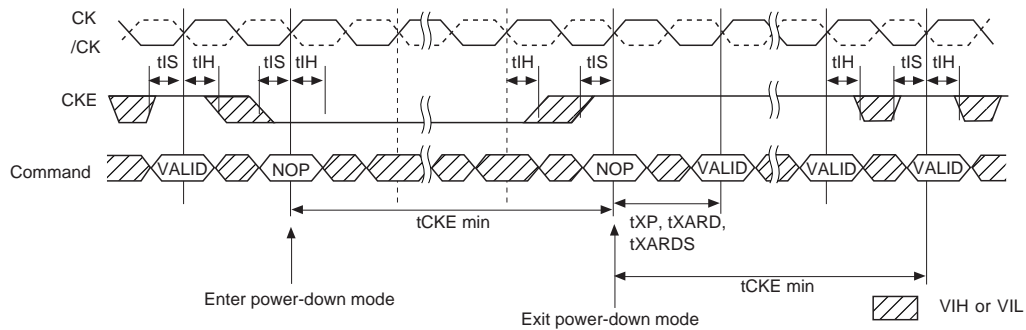

Power Down

Read to Power-Down Entry

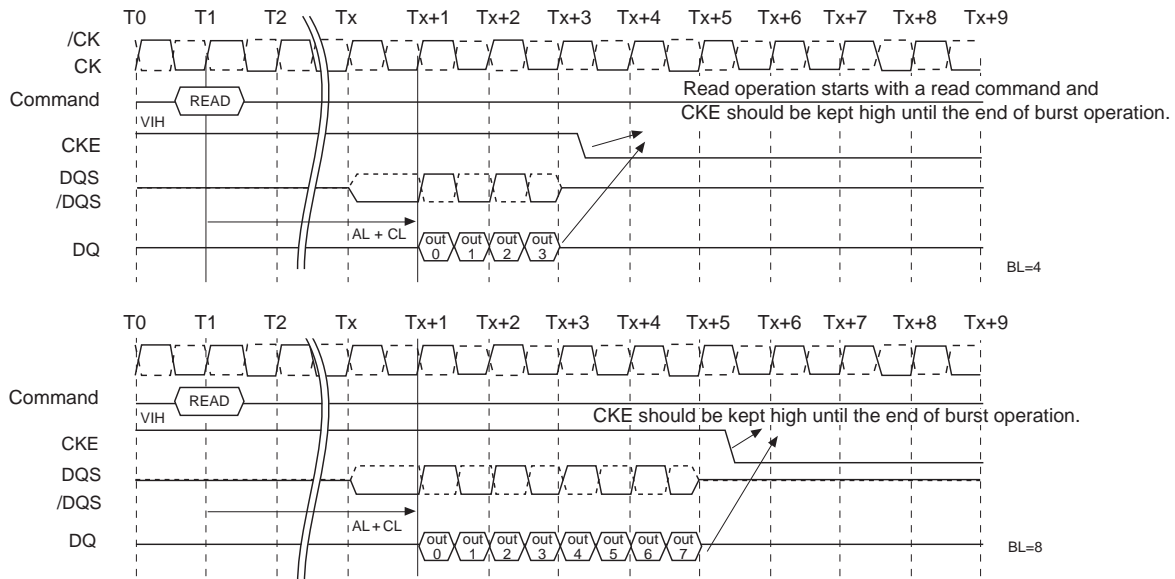

Read with Auto Precharge to Power-Down Entry

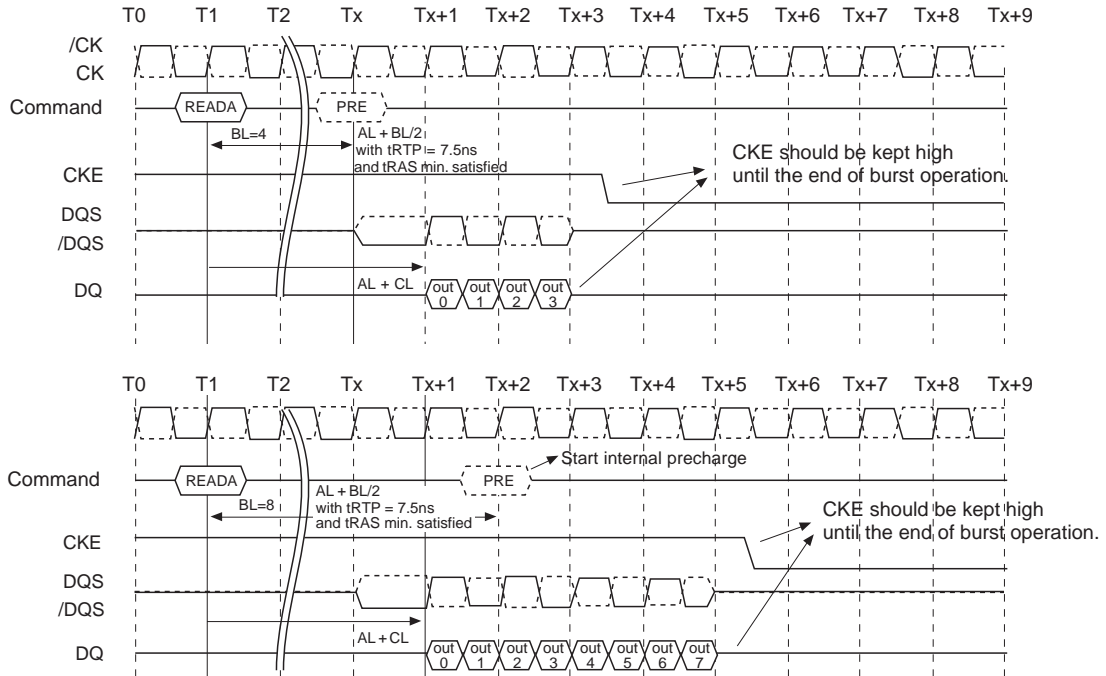

Write to Power-Down Entry

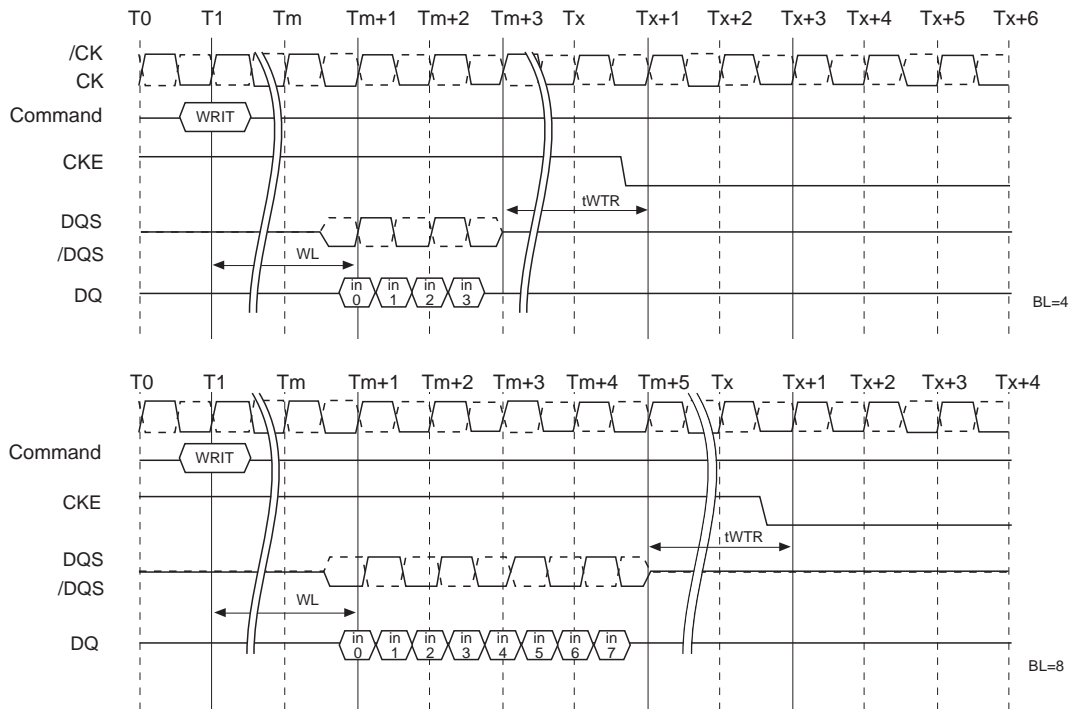

Write with Auto Precharge to Power-Down Entry

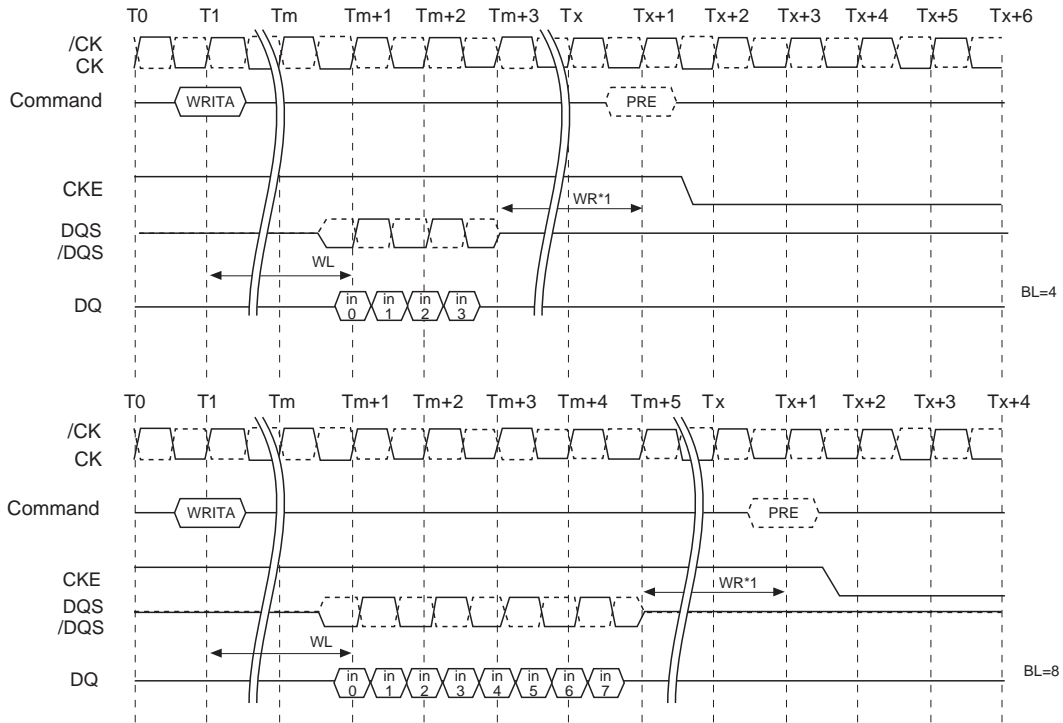

Note: 1. WR is programmed through MRS

Refresh command to Power-Down Entry

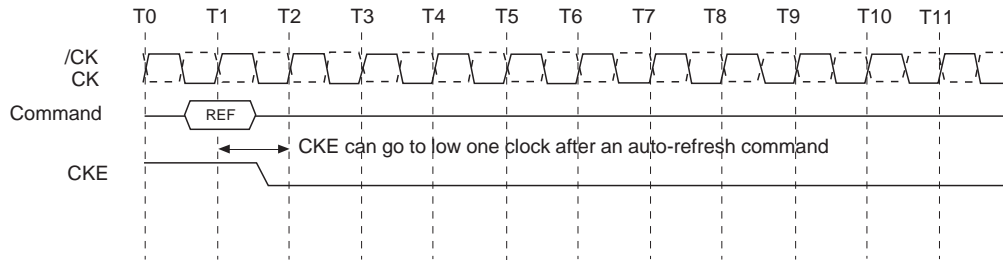

Active command to power-down entry

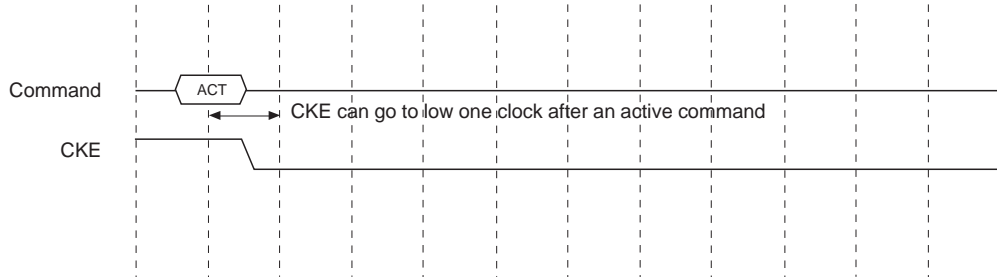

Precharge/Precharge all command to power-down entry

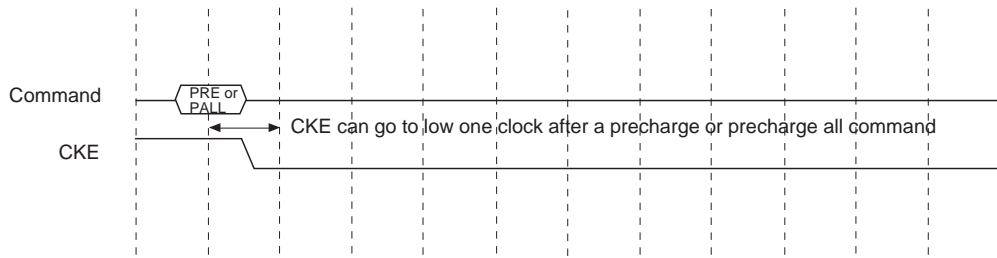

MRS/EMRS command to power-down entry

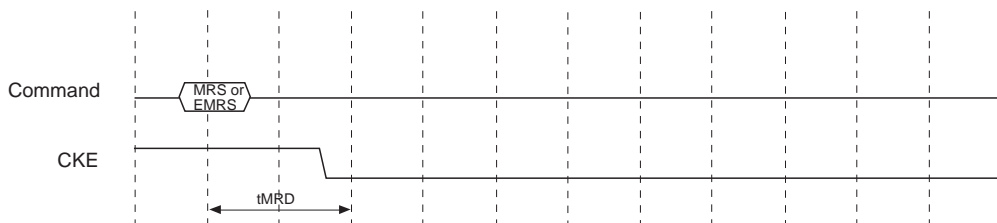

Asynchronous CKE Low Event

DRAM requires CKE to be maintained high for all valid operations as defined in this data sheet. If CKE asynchronously drops low during any valid operation DRAM is not guaranteed to preserve the contents of array. If this event occurs, memory controller must satisfy DRAM timing specification t_{DELAY} before turning off the clocks.

Stable clocks must exist at the input of DRAM before CKE is raised high again. DRAM must be fully re-initialized (steps 4 through 13) as described in initialization sequence. DRAM is ready for normal operation after the initialization sequence. See AC Characteristics table for t_{DELAY} specification

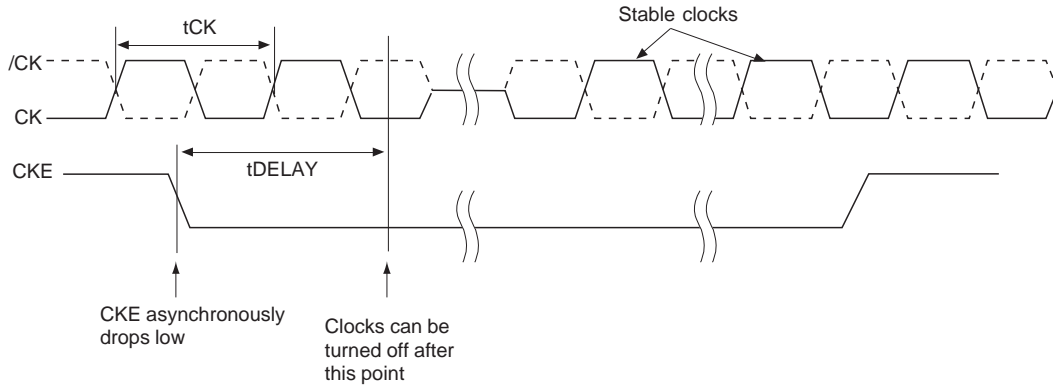

Input Clock Frequency Change during Precharge Power Down

DDR2 SDRAM input clock frequency can be changed under following condition:

DDR2 SDRAM is in precharged power-down mode. ODT must be turned off and CKE must be at logic low level. A minimum of 2 clocks must be waited after CKE goes low before clock frequency may change. SDRAM input clock frequency is allowed to change only within minimum and maximum operating frequency specified for the particular speed grade. During input clock frequency change, ODT and CKE must be held at stable low levels.

Once input clock frequency is changed, stable new clocks must be provided to DRAM before precharge power-down may be exited and DLL must be RESET via EMRS after precharge power-down exit. Depending on new clock frequency an additional MRS command may need to be issued to appropriately set the WR, CL and soon. During DLL relck period, ODT must remain off. After the DLL lock time, the DRAM is ready to operate with new clock frequency.

Clock Frequency Change in Precharge Power Down Mode

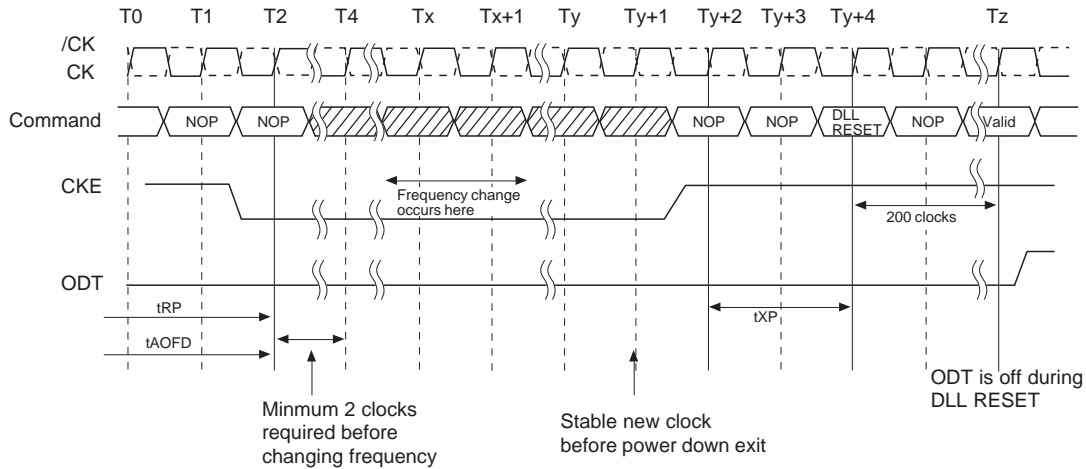

Package Drawing

60-ball FBGA

Solder ball: Lead free (Sn-Ag-Cu)

Unit: mm

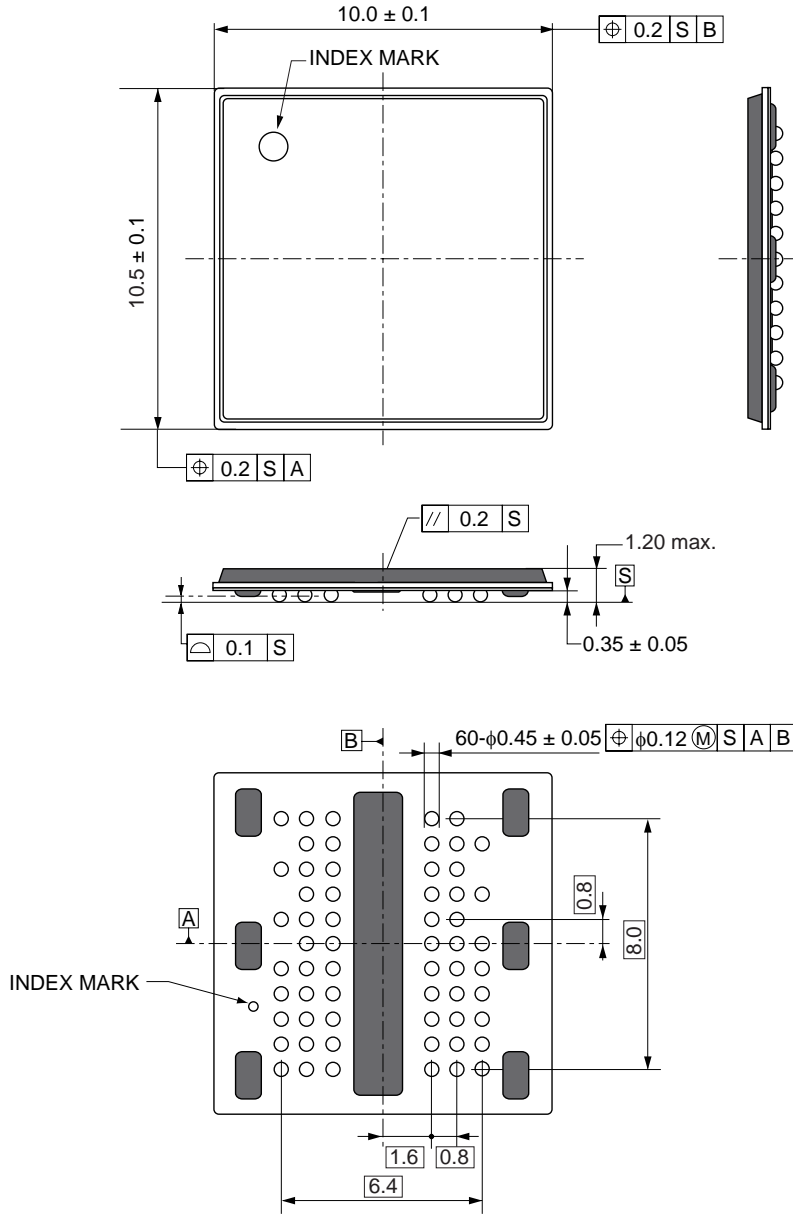

ECA-TS2-0183-01

84-ball FBGA

Solder ball: Lead free (Sn-Ag-Cu)

Unit: mm

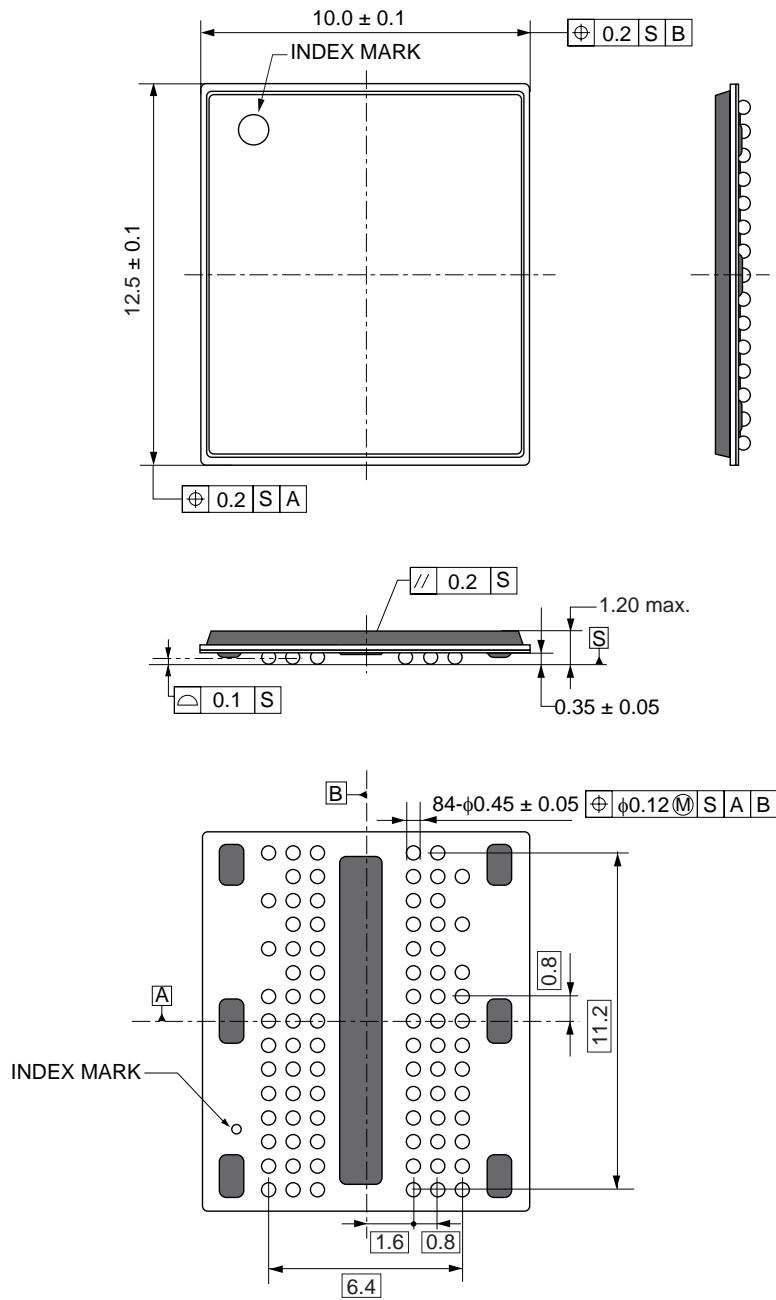

ECA-TS2-0174-01

Recommended Soldering Conditions

Please consult with our sales offices for soldering conditions of the EDE51XXAJSE.

Type of Surface Mount Device

EDE5104AJSE, EDE5108AJSE: 60-ball FBGA < Lead free (Sn-Ag-Cu) >

EDE5116AJSE: 84-ball FBGA < Lead free (Sn-Ag-Cu) >

NOTES FOR CMOS DEVICES**① PRECAUTION AGAINST ESD FOR MOS DEVICES**

Exposing the MOS devices to a strong electric field can cause destruction of the gate oxide and ultimately degrade the MOS devices operation. Steps must be taken to stop generation of static electricity as much as possible, and quickly dissipate it, when once it has occurred. Environmental control must be adequate. When it is dry, humidifier should be used. It is recommended to avoid using insulators that easily build static electricity. MOS devices must be stored and transported in an anti-static container, static shielding bag or conductive material. All test and measurement tools including work bench and floor should be grounded. The operator should be grounded using wrist strap. MOS devices must not be touched with bare hands. Similar precautions need to be taken for PW boards with semiconductor MOS devices on it.

② HANDLING OF UNUSED INPUT PINS FOR CMOS DEVICES

No connection for CMOS devices input pins can be a cause of malfunction. If no connection is provided to the input pins, it is possible that an internal input level may be generated due to noise, etc., hence causing malfunction. CMOS devices behave differently than Bipolar or NMOS devices. Input levels of CMOS devices must be fixed high or low by using a pull-up or pull-down circuitry. Each unused pin should be connected to V_{DD} or GND with a resistor, if it is considered to have a possibility of being an output pin. The unused pins must be handled in accordance with the related specifications.

③ STATUS BEFORE INITIALIZATION OF MOS DEVICES

Power-on does not necessarily define initial status of MOS devices. Production process of MOS does not define the initial operation status of the device. Immediately after the power source is turned ON, the MOS devices with reset function have not yet been initialized. Hence, power-on does not guarantee output pin levels, I/O settings or contents of registers. MOS devices are not initialized until the reset signal is received. Reset operation must be executed immediately after power-on for MOS devices having reset function.

CME0107

The information in this document is subject to change without notice. Before using this document, confirm that this is the latest version.

No part of this document may be copied or reproduced in any form or by any means without the prior written consent of Elpida Memory, Inc.

Elpida Memory, Inc. does not assume any liability for infringement of any intellectual property rights (including but not limited to patents, copyrights, and circuit layout licenses) of Elpida Memory, Inc. or third parties by or arising from the use of the products or information listed in this document. No license, express, implied or otherwise, is granted under any patents, copyrights or other intellectual property rights of Elpida Memory, Inc. or others.

Descriptions of circuits, software and other related information in this document are provided for illustrative purposes in semiconductor product operation and application examples. The incorporation of these circuits, software and information in the design of the customer's equipment shall be done under the full responsibility of the customer. Elpida Memory, Inc. assumes no responsibility for any losses incurred by customers or third parties arising from the use of these circuits, software and information.

[Product applications]

Be aware that this product is for use in typical electronic equipment for general-purpose applications. Elpida Memory, Inc. makes every attempt to ensure that its products are of high quality and reliability. However, users are instructed to contact Elpida Memory's sales office before using the product in aerospace, aeronautics, nuclear power, combustion control, transportation, traffic, safety equipment, medical equipment for life support, or other such application in which especially high quality and reliability is demanded or where its failure or malfunction may directly threaten human life or cause risk of bodily injury.

[Product usage]

Design your application so that the product is used within the ranges and conditions guaranteed by Elpida Memory, Inc., including the maximum ratings, operating supply voltage range, heat radiation characteristics, installation conditions and other related characteristics. Elpida Memory, Inc. bears no responsibility for failure or damage when the product is used beyond the guaranteed ranges and conditions. Even within the guaranteed ranges and conditions, consider normally foreseeable failure rates or failure modes in semiconductor devices and employ systemic measures such as fail-safes, so that the equipment incorporating Elpida Memory, Inc. products does not cause bodily injury, fire or other consequential damage due to the operation of the Elpida Memory, Inc. product.

[Usage environment]

Usage in environments with special characteristics as listed below was not considered in the design. Accordingly, our company assumes no responsibility for loss of a customer or a third party when used in environments with the special characteristics listed below.

Example:

- 1) Usage in liquids, including water, oils, chemicals and organic solvents.
- 2) Usage in exposure to direct sunlight or the outdoors, or in dusty places.
- 3) Usage involving exposure to significant amounts of corrosive gas, including sea air, CL₂, H₂S, NH₃, SO₂, and NO_x.
- 4) Usage in environments with static electricity, or strong electromagnetic waves or radiation.
- 5) Usage in places where dew forms.
- 6) Usage in environments with mechanical vibration, impact, or stress.
- 7) Usage near heating elements, igniters, or flammable items.

If you export the products or technology described in this document that are controlled by the Foreign Exchange and Foreign Trade Law of Japan, you must follow the necessary procedures in accordance with the relevant laws and regulations of Japan. Also, if you export products/technology controlled by U.S. export control regulations, or another country's export control laws or regulations, you must follow the necessary procedures in accordance with such laws or regulations.

If these products/technology are sold, leased, or transferred to a third party, or a third party is granted license to use these products, that third party must be made aware that they are responsible for compliance with the relevant laws and regulations.

M01E0706